

PAVEMENT DEFLECTION MEASUREMENT-DYNAMIC

PHASE II

3.2

FINAL REPORT

by

Frank Brands, P.E.  
Electrical Engineering Section

and

John C. Cook, P.E.  
Highway Research Section



WASHINGTON STATE UNIVERSITY  
COLLEGE OF ENGINEERING  
RESEARCH DIVISION



PAVEMENT DEFLECTION MEASUREMENT-DYNAMIC

PHASE II

FINAL REPORT

by

Frank Brands, P.E.  
Electrical Engineering Section

and

John C. Cook, P.E.  
Highway Research Section



PAVEMENT DEFLECTION MEASUREMENT-DYNAMIC

PHASE II

FINAL REPORT

by

Frank Brands, P.E.  
Electrical Engineering Section

and

John C. Cook, P.E.  
Highway Research Section

College of Engineering Research Division  
Washington State University  
Pullman, Washington  
June 1971

Prepared for  
Washington State Highway Commission  
Department of Highways  
in cooperation with  
U. S. Department of Transportation  
Federal Highway Administration

Project No. Y-1389

The opinions, findings and conclusions expressed in this publication are those of the authors and not necessarily those of the Washington State Highway Commission, Department of Highways or the Federal Highway Administration.

(Highway Research Section Publication H-35)



## TABLE OF CONTENTS

	Page
LIST OF ILLUSTRATIONS	iii
ABSTRACT	iv
SUMMARY	v
CONCLUSIONS	vi
CHAPTER I Introduction and Review of Previous Work	1
CHAPTER II Procedure - Design Criteria	9
CHAPTER III Discussion - Detailed Design of Trailer Vehicle	13
CHAPTER IV Discussion - Belt Selection and Tracking	17
CHAPTER V Discussion - Instrument Carriage Design	21
CHAPTER VI Discussion - The Impulse Hammer	27
CHAPTER VII Applications and Exhibits	29





## LIST OF ILLUSTRATIONS

Figure		Page
I-1	Profile of Response of Impulse Testing Compared with Dynaflect (Mile Post 19)	4
I-2	Profile of Response of Impulse Testing Compared with Dynaflect (Moscow Highway)	5
I-3	Profile of Response of Impulse Testing Compared with Dynaflect (New Road)	6
I-4	Impulse Index Bar Chart	7
II-1	Belt Mechanism	11
II-2	Diagram Showing Retractable Inner Frame	12
III-1	Inner Frame Assembly	14
III-2	Diagram Showing Inner and Outer Frames	16
V-1	Carriage Assembly	22
V-2	Carriage Support Assembly	23
VI-1	Pneumatic Hammer Linkage (Bacharack Mechanism)	28
VII-1	Test Model Trailer Vehicle	30
VII-2	Sequence Indicating Manner in which Instrument Carriage is set on Pavement	31
VII-3		
VII-4		
VII-5	The Impulse Hammer & Carriage	32
 Table		
IV	Test on Wear Resistance of Conveyor Belts	18



## ABSTRACT

The Impulse Index as a measure of pavement condition was previously described in a report of the Research Division of Washington State University entitled, "Pavement Deflection Measurement - Dynamic--A Feasibility Study, Final Report, June 1970," by Frank W. Brands, P. E. and John C. Cook, P. E.

Implementation of automatic data acquisition using impulse testing requires the development of a mechanical device to set an instrument package on the pavement, deliver an impulse of energy, and retrieve the instrument package. This is to be done automatically with the vehicle proceeding down the highway. This report describes a test model built to facilitate the determination of data necessary for design of a prototype vehicle.



## SUMMARY

The actual time required to obtain the necessary data with which to compute the Impulse Index is only a few milliseconds. It is therefore reasonable to build a vehicle which will automatically perform the required functions to implement the acquisition of the desired data while the vehicle maintains forward velocity down the highway. Such a system, when fully developed, will permit fast and automatic logging of the pavement condition for an entire highway system, thus aiding the management of the highway system and assisting in the establishment of maintenance priorities.

In order to successfully design such a mechanical device, a test model was constructed to facilitate the determination of the data necessary to build a prototype vehicle. The test model was designed with sufficient adjustment capability to permit measurements under various mechanical conditions. It was also built with sufficient strength and free clearance room between moving parts to permit tests to be conducted of various alternatives of achieving the desired results.

This report describes the test model in detail. Photographs and diagrams are included where appropriate. It is anticipated that this model will be useful in determining the most satisfactory method of automatically performing the necessary mechanical functions to permit the automatic acquisition of data required to compute the Impulse Index. One system has been installed on the model, and is described in this report. An improved system has been considered, and it is anticipated that it will be installed in a future project.



## CONCLUSIONS AND RECOMMENDATIONS

The test model has been built to permit the determination of information necessary to build a prototype vehicle. One system for depositing the instrument package on the pavement at the front of the vehicle and retrieving it at the back of the vehicle as the vehicle progresses down the highway has been installed on the test model. This method involves the use of a continuous belt arranged in a manner similar to a crawler tractor tread. The instrument package is secured to the belt in a cantilever arrangement and as the belt moves in the manner of a crawler tread, the instruments are deposited on the pavement at the front of the vehicle, remain stationary on the pavement for a short time, and then are picked up at the rear of the vehicle as that point on the belt goes around the rear belt support. As installed, a flat belt has been used. Road tests up to 30 miles per hour have been conducted without the instrument carriage attached, and the belt remained on its pulleys. However, on turns there is a tendency for the lateral forces developed to pull the belt off of its supports.

It is recommended that a modified configuration be designed and tested in a future project. The modification that appears to be most promising at this time is to secure a series of lugs to the belt, making it similar to a large vee belt. The supporting pulleys would have to be replaced with a configuration suitable for accepting the vee belt. Several industrial type snow vehicles are equipped with tracks of this type and appear to have been proven reliable.

This improved configuration would also permit the transducer supports to be embedded in the belt, giving better dynamic balance to the system. Small telemetering type transmitters, also located in the lugs would transmit the electrical signals from the transducers to a receiver on the frame of the vehicle where the Impulse Index would be computed.

The vehicle has been designed with an inner and outer frame as described in Chapter III of this report. The inner frame carries the working parts and can be raised from the roadbed for transporting the vehicle between test sites. A pneumatic hammer described in Chapter VI of this report provides the impulse to the pavement when the carriage is in the proper position relative to the frame.



## CHAPTER I

### INTRODUCTION AND REVIEW OF PREVIOUS WORK

In this report, reference is made to a previous report of the Research Division of Washington State University, entitled "Pavement Deflection Measurement - Dynamic--A Feasibility Study, Final Report, June 1970," by Frank W. Brands, P. E. and John C. Cook, P.E., and prepared for the Washington State Highway Commission, Department of Highways, in Cooperation with the U. S. Department of Transportation, Federal Highway Administration, Project No. Y-1205.

In that report, a new system of nondestructive testing of highway pavement was described. This system, called "impulse testing" is adaptable to mechanization for automatic operation. The system is based on the deflection of the pavement under impulse loading, and also on the energy propagation characteristics of the pavement. These two parameters are combined to formulate a quantity which is called the impulse index and which has a high degree of correlation with the structural properties of the pavement.

The data required to compute the impulse index of a particular position on a pavement is acquired from two transducers, such as accelerometers, positioned on the pavement and separated by a known distance. Eighteen inches is a satisfactory distance, although consistency and repeatability are of more importance than the exact value of the spacing. An impulse, such as a hammer blow of controlled energy, is delivered to the pavement very close to one of the transducers. The electrical signals from the transducers are then used to compute the impulse index.

Supporting data indicating the value of the impulse index and its correlation with other methods of pavement evaluation are presented in the aforementioned report. All of that data was acquired by manually placing the transducers on the pavement and manually operating the hammer which provided the impulse. Such a technique is certainly satisfactory for determining the value of the impulse index as a measure of pavement condition. However, the impulse testing technique basically requires only a few milliseconds to collect the data, and hence has high potential for automatically testing the pavement from a vehicle moving at speeds greatly in excess of Benkelman Beam, Dynaflect, or Traveling Deflectometer equipment.

In order to take full advantage of the fact that the impulse testing technique requires only a few milliseconds, it is necessary to develop the mechanical equipment which will perform automatically the operation of placing the transducers on the pavement, produce the required hammer blow, and retrieve the transducers. An approach to the solution of this problem was presented in the feasibility study. In order to acquire the necessary information to render a satisfactory mechanical design, one of the main objectives of this study as reported herein was to construct a half scale limited capability working model designed in such a manner as to permit adjustments and alterations as required. The information acquired from this model will be useful in the design of a prototype model for actual highway operation. This information is a necessary step toward the design of an operational unit capable of rapidly and conveniently monitoring highway pavement condition.

Some illustrative results of impulse testing are included here for convenience. Figs. I-1, I-2 and I-3 show the profile of response from a set of three transducers using the impulse technique, and the results are plotted along with Dynaflect data taken at nearly the same points. Due to the configuration of the Dynaflect, the actual Dynaflect readings were taken somewhat toward the lane center from the outside wheel track of the pavement. The impulse test results, being much less cumbersome to obtain, were taken at the outside wheel track and also at the lane center. Notice that in each case, the Dynaflect profile falls between the impulse test profiles. This is exactly where it should be taking into account the expected deterioration of the pavement in the wheel track. Of particular significance on these curves is the obviously steeper profile of the impulse data taken in the wheel track compared to the data taken in the lane center for Mile Post 19 on the Lewiston highway and again on the Moscow highway. On the new road, this difference is significantly less because the pavement has not yet received much use.

As a means of numerically evaluating the data from the transducers, the impulse index is computed from the transducer signals. The bar chart of Fig. I-4 clearly indicates the impulse index being higher for the wheel tracks than for the lane center on the Lewiston and Moscow highways, which have been in service for a number of years.

Mile Post 19

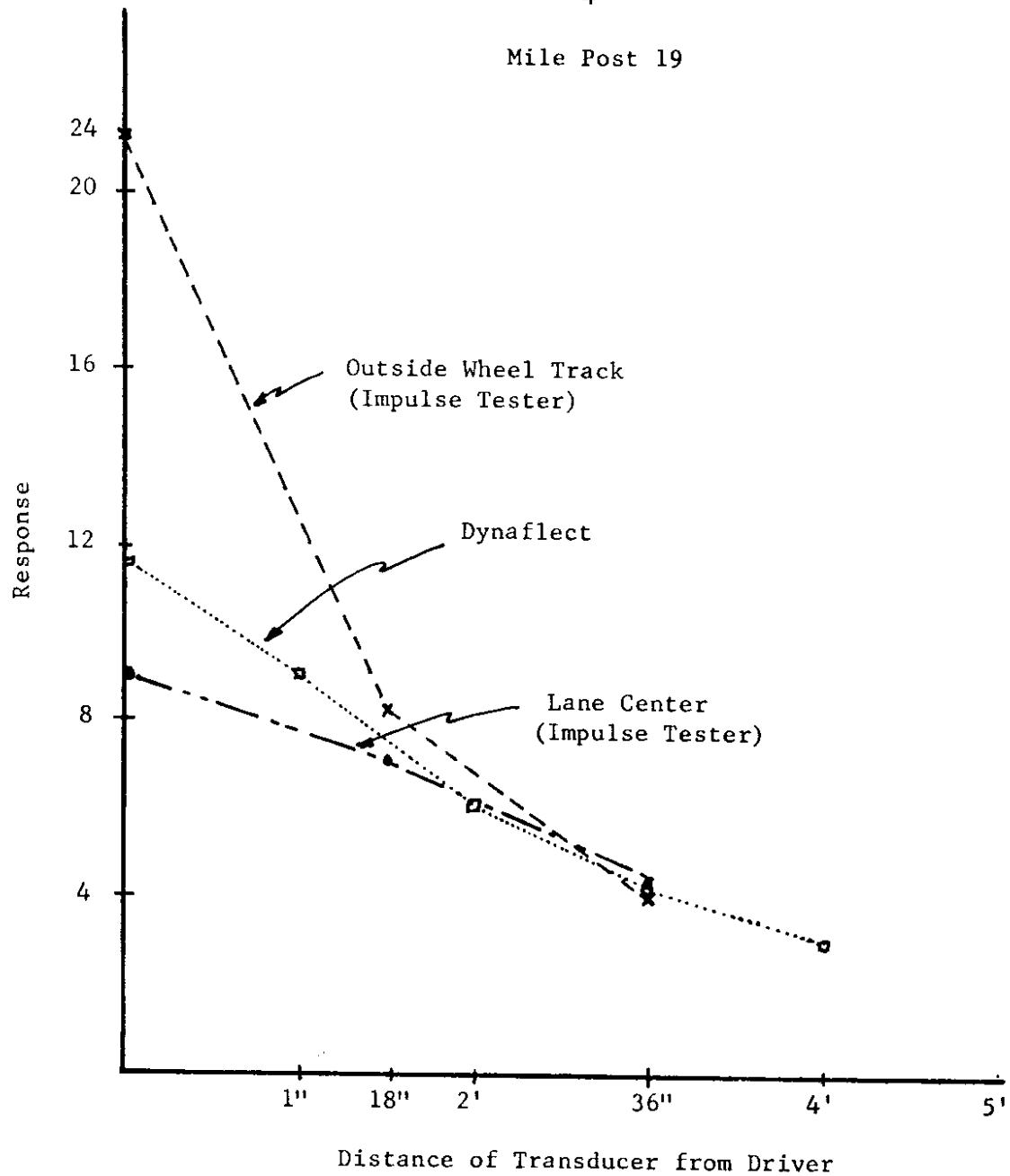

Comparison of data from the transducer of the impulse tester compared to the data from the transducers of the Dynaflect. To facilitate comparison, the Dynaflect readings were scaled up by a factor of 10.

FIGURE I-1

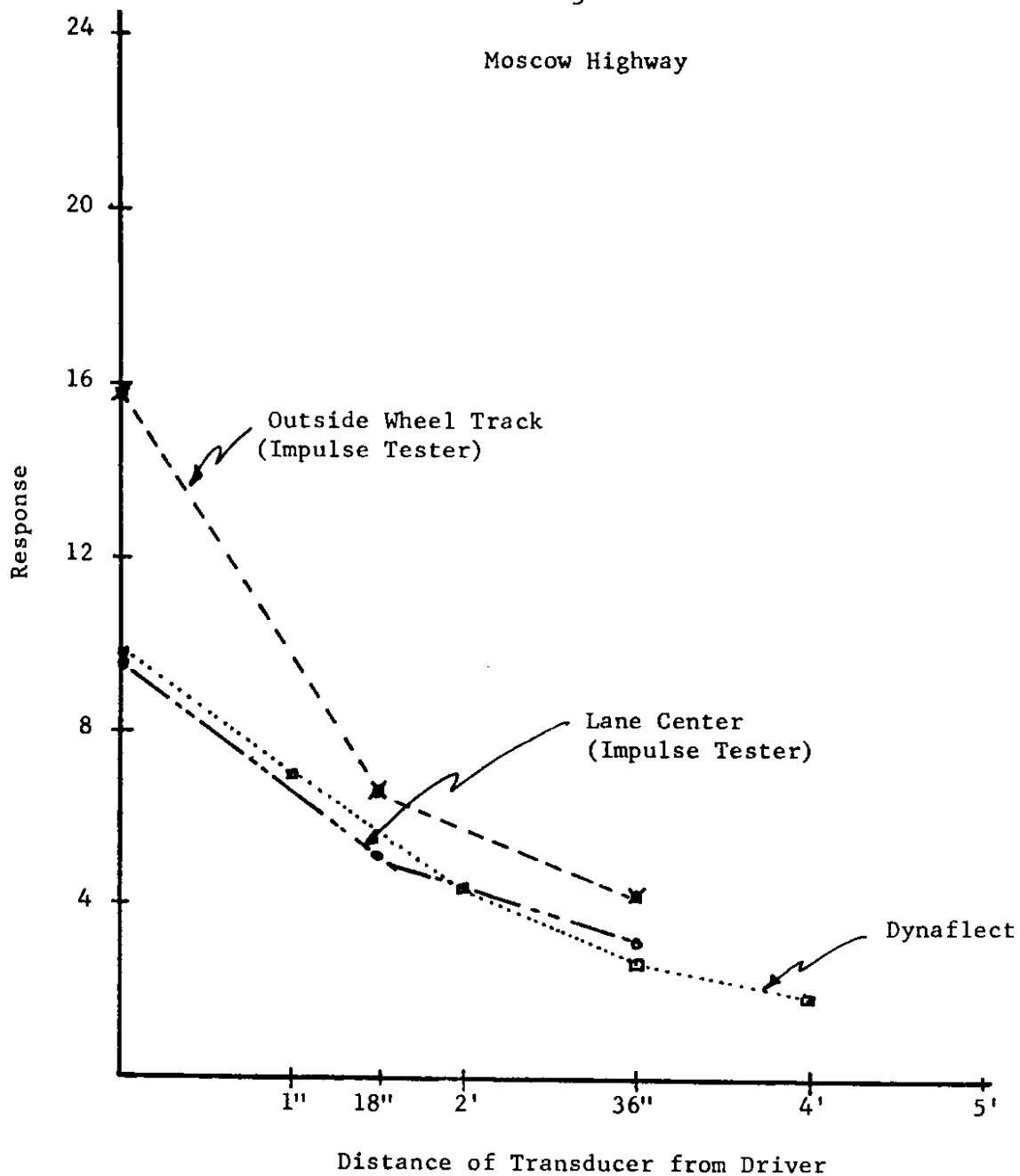

Comparison of data from the transducer of the impulse tester compared to the data from the transducers of the Dynaflect. To facilitate comparison, the Dynaflect readings were scaled up by a factor of 10.

FIGURE I-2

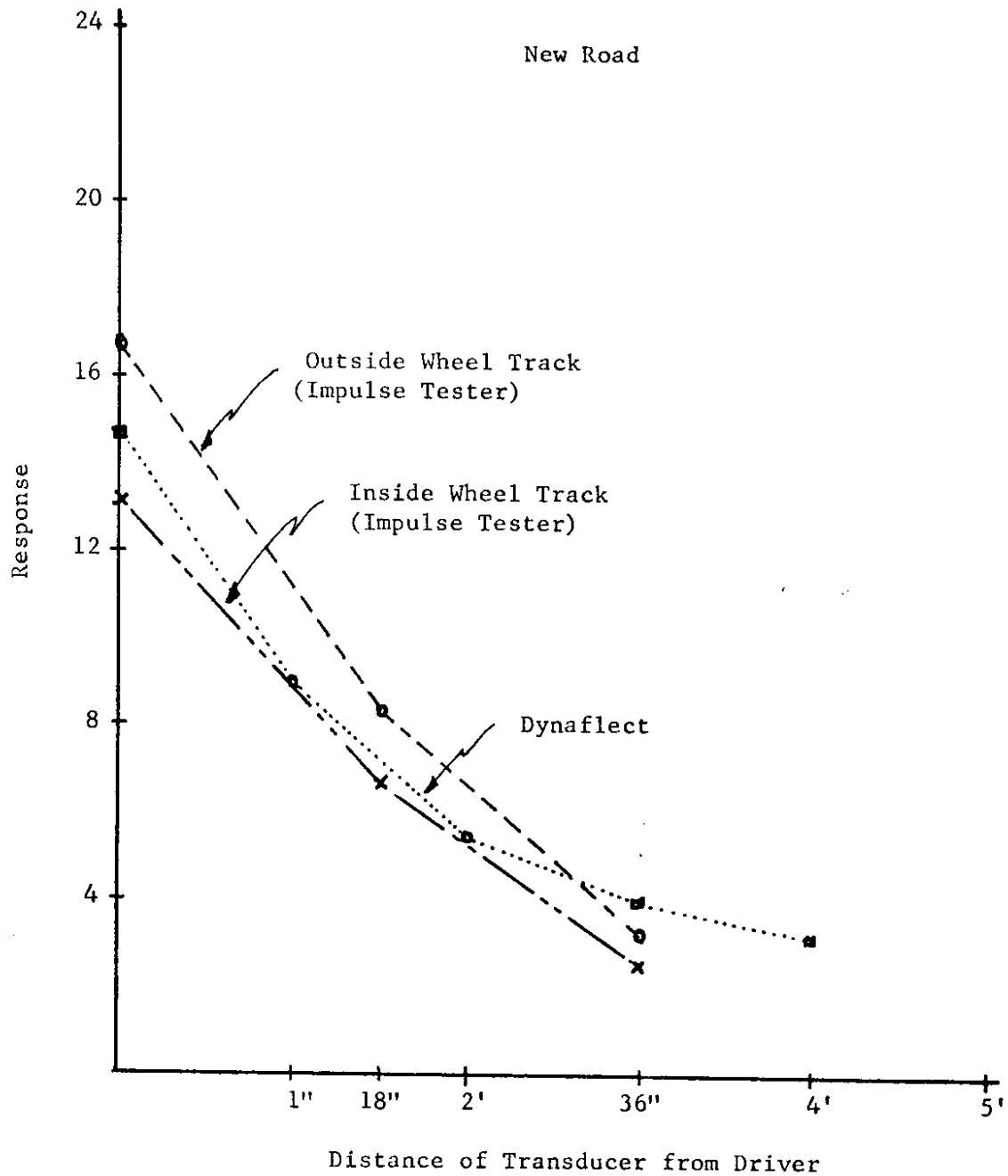

Comparison of Data from the transducer of the impulse tester compared to the data from the transducers of the Dynaflect. To facilitate comparison, the Dynaflect readings were scaled up by a factor of 10.

FIGURE I-3

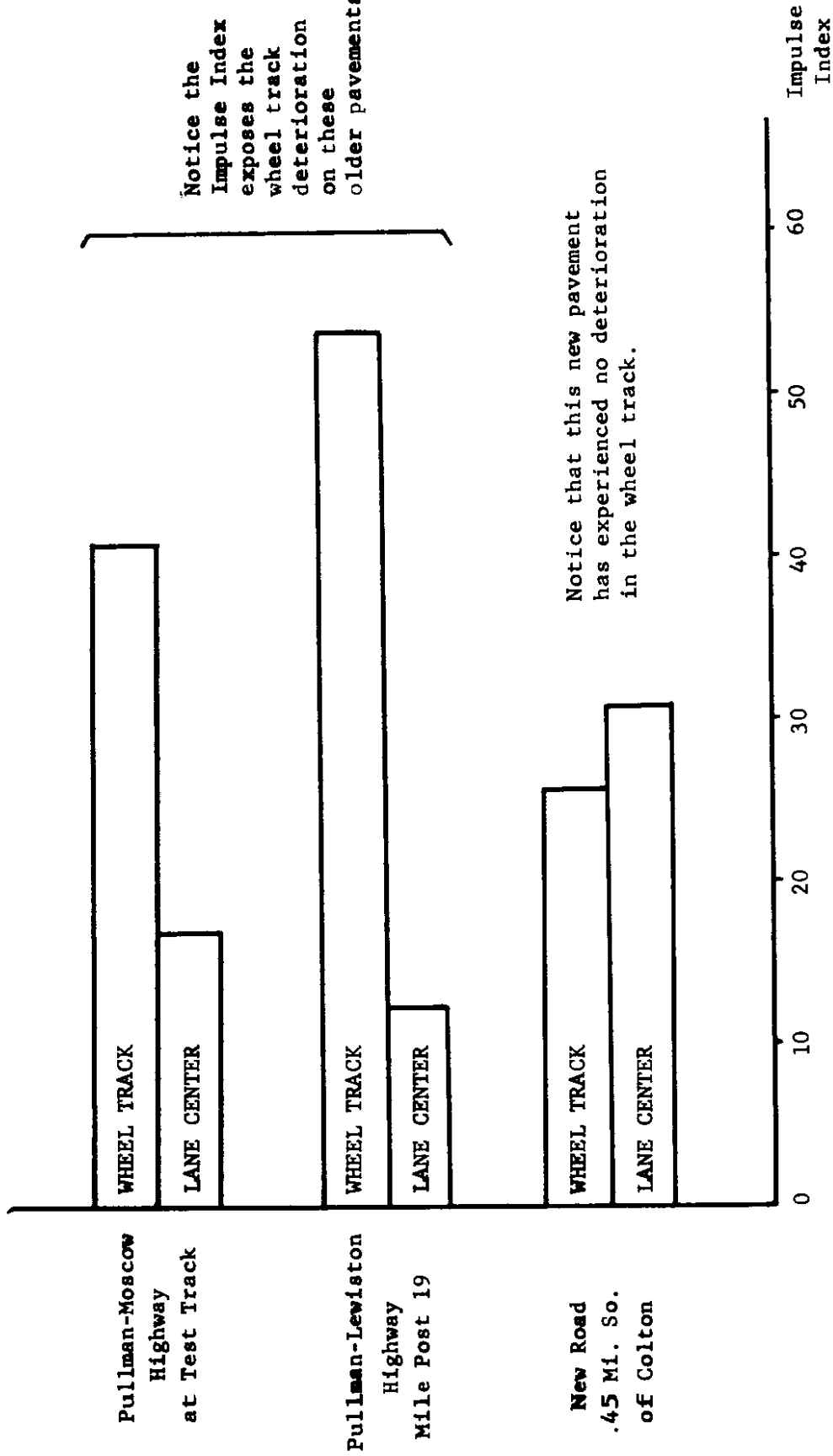

FIGURE I-4

Impulse Index Bar Chart





## CHAPTER II

PROCEDURE - DESIGN CRITERIA

The mechanical device is to properly position, on the highway pavement, the two transducers required to compute the impulse index. After properly positioning the transducers, the device must produce a hammer blow of controlled energy (approximately 5 foot-pounds is satisfactory) at a point very close to one of the transducers. During the next 50 milliseconds after the hammer blow, the useful signals are being produced by the transducers, and after this period the transducers are to be picked up by the mechanical device, transported down the road to a new location, and the entire operation is repeated.

As a theoretical upper limit on achievable vehicle velocity, one might consider how far a vehicle would advance in the 50 milliseconds actually required for the reading to be taken. If the vehicle were traveling at 30 MPH, in 50 milliseconds it will advance only 2.2 feet. At 60 MPH the vehicle would advance 4.4 feet. A twenty-foot long vehicle would have to be traveling at 272 MPH to advance its length in 50 milliseconds. Hence, it is quite reasonable to consider a vehicle which will place an instrument package containing the transducers on the pavement at the front end of the vehicle, and while proceeding down the highway, retrieve the instrument package at the rear of the vehicle. Once retrieved, the instrument package would be transported back to the front of the vehicle and the operation repeated.

As is usually the case, however, it would be unreasonable to expect upper limit operation to be achieved. To do this would require infinite

accelerations and zero transitional and settling times. Some of the parameters which will be obtainable from the model which has been built are reasonable values of time required for the placing and retrieving operations and also the settling time required for the transducers to quiet down after the mechanical shock induced in them during the placing operation.

The basic idea developed for performing the required operations can best be described using as a reference Fig. II-1. An endless belt used in a manner similar to the tread of a crawler tractor has a support attached in a cantilever manner. On the support is mounted a carriage which contains the two transducers. The electrical signals from the transducers are carried by a coiled wire similar to a telephone wire, and to prevent it from being continually twisted or wrapping around the axle shafts the carriage must be mounted on its own spindle and the wheels and pulleys supporting the belt must all be cantilevered. The lower part of the belt must have zero velocity with respect to the pavement, and it is when the instrument carriage is riding in this position that the transducers are in contact with the pavement and readings can be taken. The length of the belt in this region is approximately ten feet on the model. This was considered to be ample length to permit the desired measurements to be made. The angle with which the belt approaches the pavement is adjustable in order to provide variations in the angle at which the carriage approaches the pavement when it is being set down.

To provide for ease in transporting the device, the belt and its supporting wheels and pulleys were to be designed to be retractable, as shown in Fig. II-2.

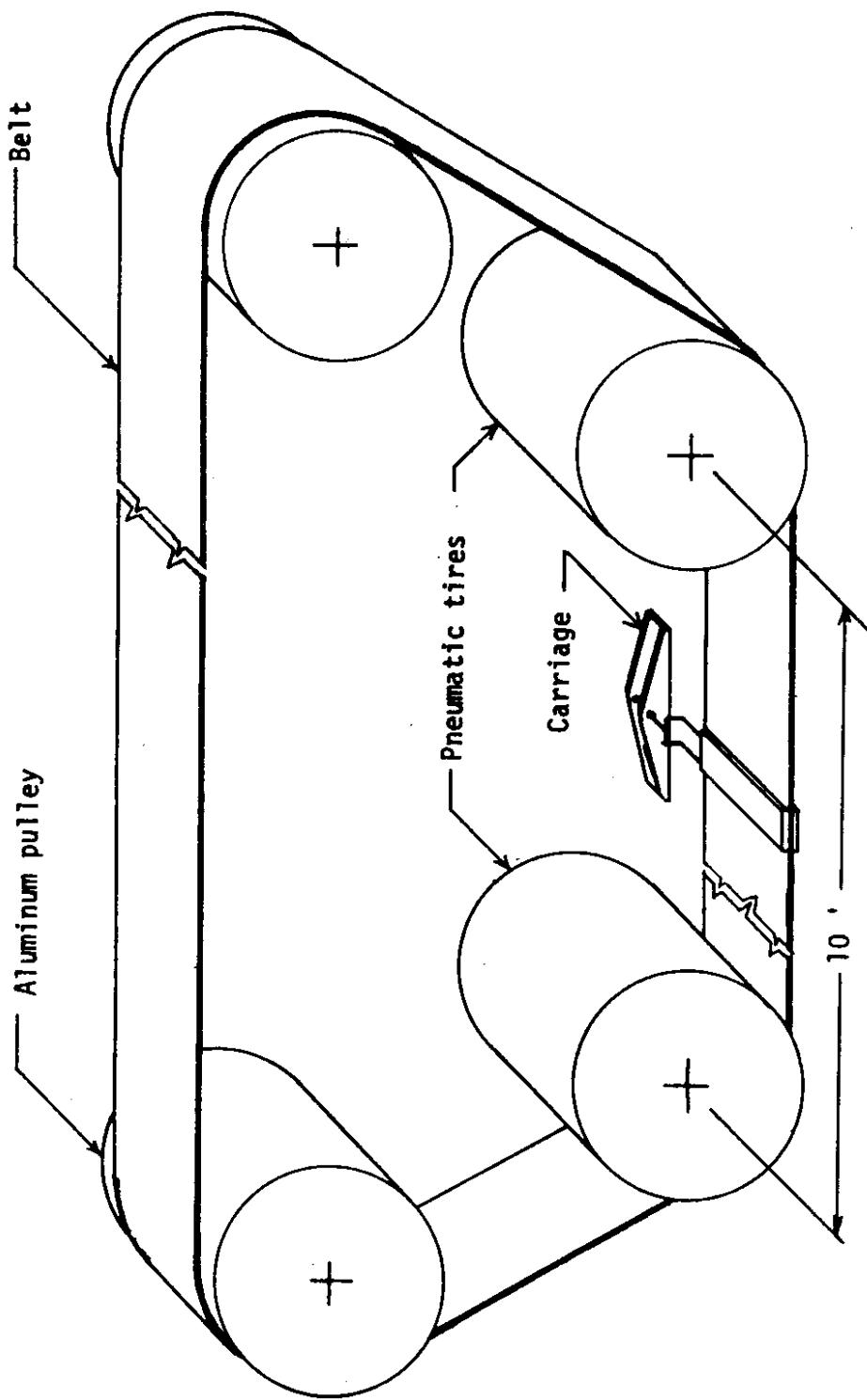

FIGURE II-1  
Belt Mechanism

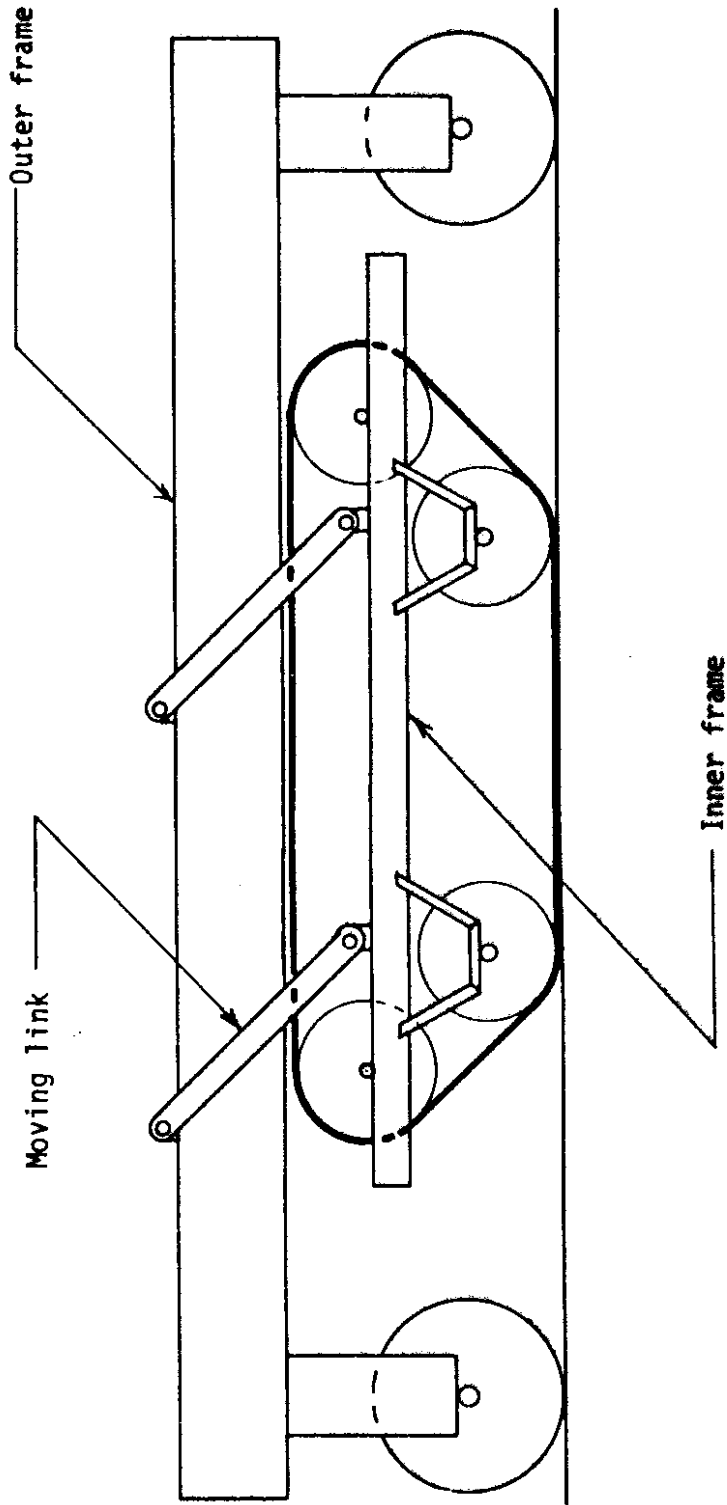

FIGURE II-2  
Diagram Showing Retractable Inner Frame

## CHAPTER III

DISCUSSION - DETAILED DESIGN OF TRAILER VEHICLE

In order to achieve the required criteria, a design concept was used employing two box frames, one of which nests inside the other.

The smaller inner frame is made of aluminum and carries the pulleys and wheels which support the belt. A drawing of the inner frame is reproduced in Fig. III-1. When the inner frame is lowered, the belt is in contact with the ground and the frictional forces cause the belt to move so that the lower part has zero velocity with respect to the ground. Two pneumatic tired wheels and two aluminum pulleys with crowns support the belt. The pneumatic tires have a crown also and serve nicely to cushion the road shocks as the vehicle rolls along the highway. The crowns help hold the belt on the wheels and pulleys. The box frame design provides the rigidity which is essential in keeping the pulleys and wheels aligned.

As can be seen clearly from the top view in Fig. III-1, the wheels and pulleys are mounted cantilever from the inner side of the inner frame. Ample free space is therefore provided for the carriage and the required signal wires. It might be noted at this time that other schemes were considered for getting the signal from the transducers to the main frame. These are discussed in Chapter V.

The pulleys and the wheels can be moved in the horizontal direction. This can be seen from a close examination of Figure III-1, and this feature permits the angle of approach of the belt with the ground to be adjusted. In order to reduce the settling time of the transducers and also to prevent physical damage to them they should be placed on the ground as gently as

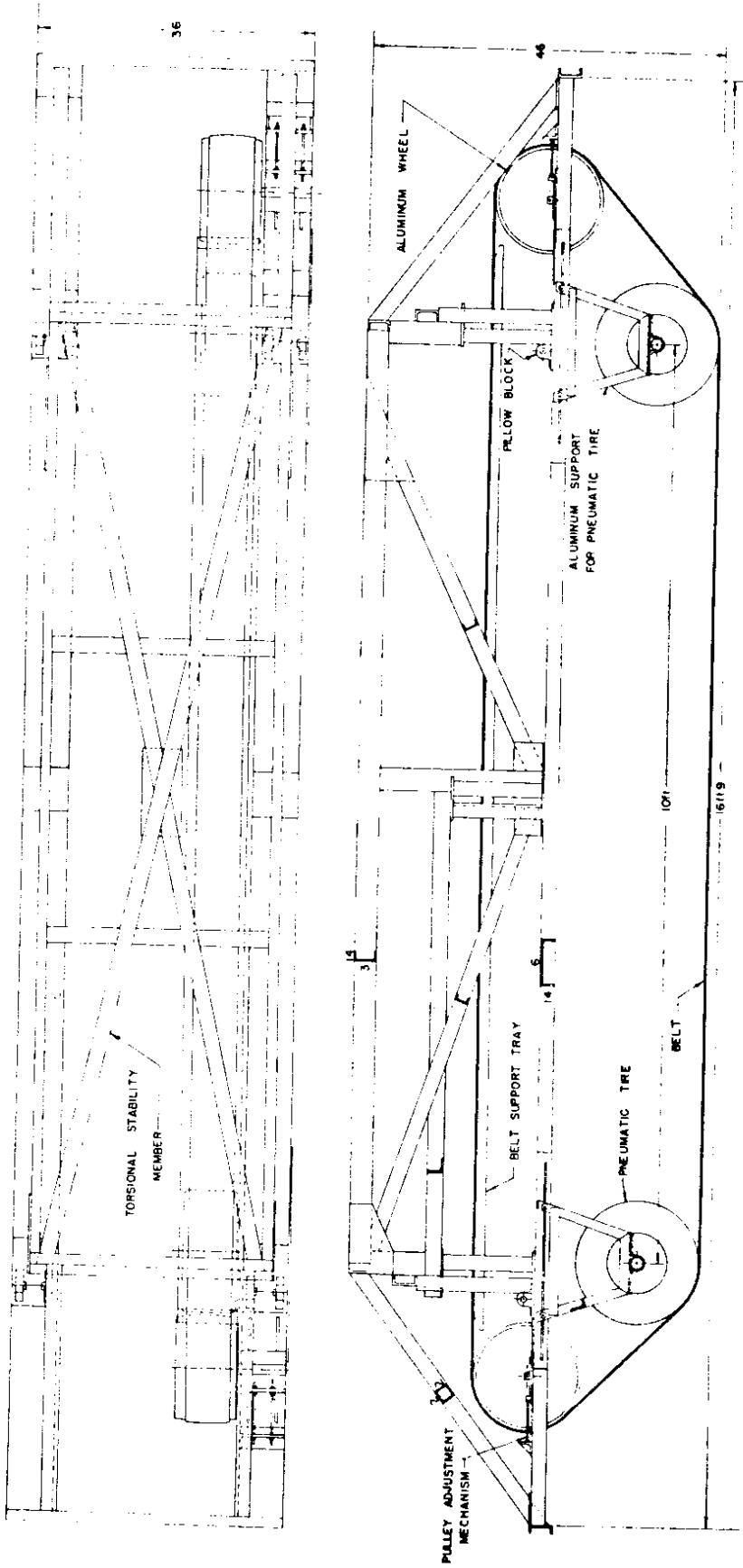

FIGURE III-1  
Inner Frame Assembly

possible. The adjustable approach angle was therefore considered a desirable feature. The instrument carriage is not shown in the diagram of Fig. III-1.

The outer frame is made of steel and is also a box type of construction. Its main function is to support the inner frame and to serve as a vehicle for transporting it when not in use. Fig. III-2 is a drawing of the outer frame with the inner frame tucked inside. The inner frame and outer frame are coupled together with a four bar linkage which ensures true alignment but permits the inner frame to be lowered for use. The inner frame is raised and lowered by a hand operated winch and steel cables. Draw bolts are used to lock the inner frame in the raised position when the trailer is being towed to the test site. When the inner frame is in the lowered position, part of its weight is used to press the belt against the pavement for traction. Some of the weight, however, is carried by four springs coupled to the outer frame. These springs are on adjustable brackets so that the amount of weight carried by the springs and the amount carried by the belt support can be adjusted. The outer frame is equipped with a towing bar and ball hitch and the entire vehicle can be towed with a station wagon. Legal tail and stop lights are also provided.

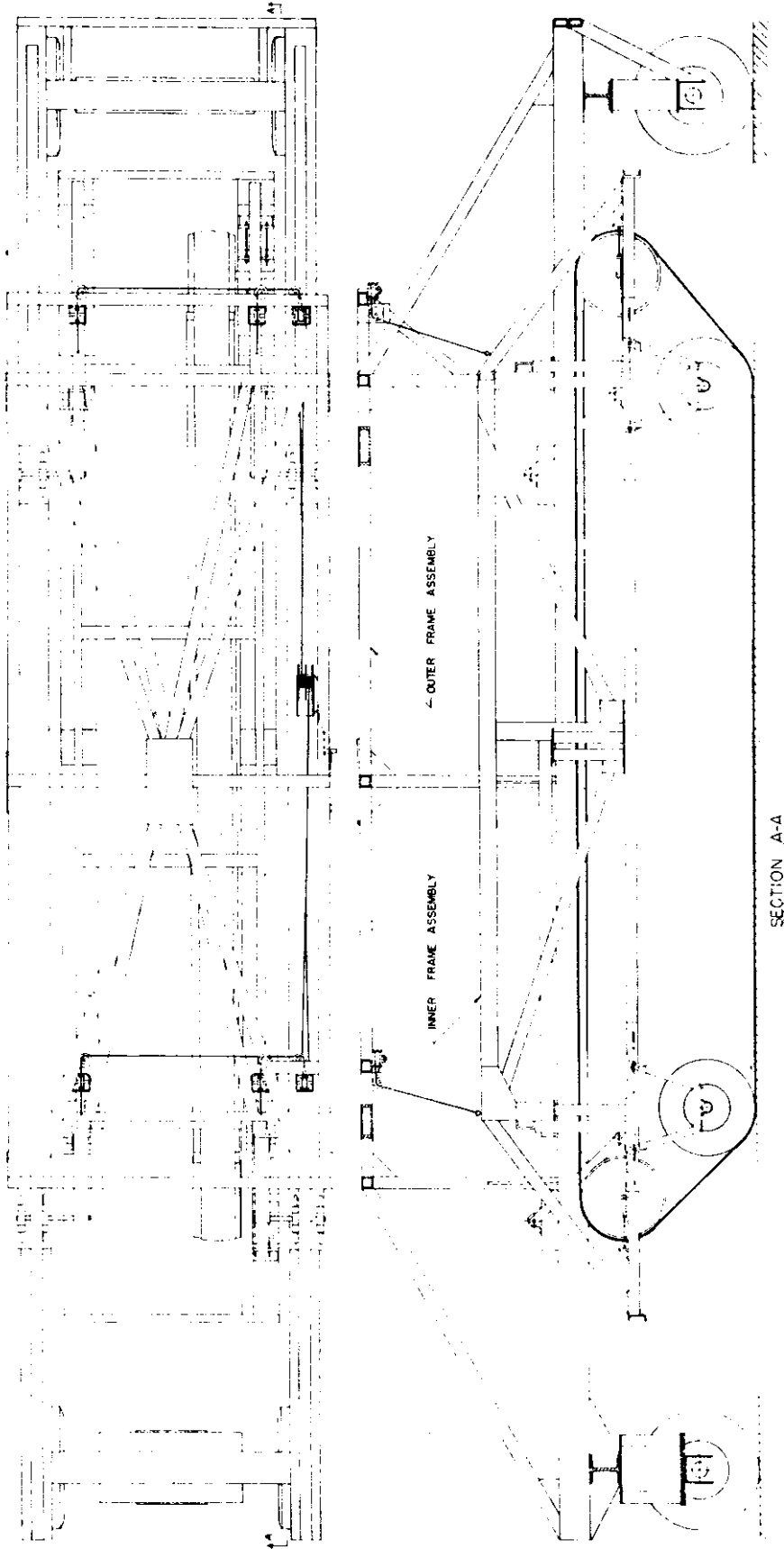

FIGURE III-2

Diagram Showing Inner and Outer Frames



## CHAPTER IV

DISCUSSION - BELT SELECTION AND TRACKING

Three criteria were established to govern belt selection; belt wear, belt twist, and belt creep resistance.

Belt Wear Tests

Belt samples were obtained from two leading firms. Small samples of about 1 by 1 inch were cut from the samples supplied. The samples were numbered and weighed to the nearest thousandth of a gram. Each sample was then placed inside an abrasive testing machine, which directed a blast of air and silicon carbide grit on the belt surface. Fifty grams of silicon carbide powder of Grit-60 was used for each sample. After all samples had been air blasted with the fifty grams of Grit-60 silicon carbide, they were each weighed. Loss in weight indicated the amount the belt surface had abraded by the silicon carbide. Low loss of belt material would indicate high wear resisting properties. The results obtained from the tests conducted on various samples are shown in Table IV-1.

Belt Torsion Test

Belt torsion tests at various belt tensions were conducted. A 5-foot long belt sample was clamped between two belt clamps and the belt tension was increased by tightening tension bolts. A spring balance between the tension bolts and the belt clamp indicates the belt tension. After the belt had been tensioned to 200 pounds, a 3-pound weight, which is approximately the weight of the instrument carriage, was suspended like a cantilever near the middle of

TABLE IV-1

Test on Wear Resistance of Conveyor Belts

SE No.	Type	Initial Wt. (grams)	Final Wt. (grams)	Difference (grams)
GOODYEAR'S				
1	Pylon 140	4.7618	4.7417	0.0201
2	Pylon 2210	5.8996	5.8796	0.0200
3	Pylon 210	7.5880	7.5653	0.0227
4	Pylon 315	8.2336	8.2093	0.0243
5	Pylon 420	10.1183	10.0819	0.0364
6	Pylon 525	12.8039	12.7325	0.0714
7	Pylon 630	14.5400	14.4856	0.0544
R M, INC.				
1	Victor ROH-4Ply	3.3653	3.3400	0.0253
2	RM-210-2Ply	6.1379	6.1203	0.0176
3	Tray Belt-4Ply	3.8065	3.7884	0.0181
4	RM-140-2Ply	4.1677	4.1563	0.0114
5	Macco Neoprene 4Ply	3.9087	3.8815	0.0272
6	RM-280-3Ply	6.7564	6.7435	0.0129

NOTE: Abrasion Material: Silicon Carbide Powder Grit-60

Weight of SiC used per test = 50 + .01 grams

the 5-foot belt sample. Due to the eccentric weight the belt would twist and the weight drop. The initial and final belt edge height from the ground was measured to give the belt twist in inches. The tension was increased in increments of 50 pounds to a maximum of 600 pounds, and the belt twist measured in each case.

#### Belt Creep Tests

Creep refers to the belt extension under load over a period of time. Extension in length would permit an increase in belt twist due to the resulting decreased tension.

As the belt tension is increased, the wheels and pulleys convey a heavier bending moment to the main aluminum channel of the inner frame. If too low a belt tension is maintained then the instrument carriage would have a tendency to sag excessively.

On the basis of availability and the results of the precedings tests, RM-280, 3-ply belting was selected.

#### Belt Tracking Technique

During the initial road tests of the vehicle, the belt had a tendency to run off the pulleys whenever even very gentle turns were negotiated. The crown on the pulleys and tires did not provide sufficient stabilization to hold the belt on when it was subjected to the lateral forces generated in the turns. The following modification proved to substantially overcome the problem except in more severe turns.

The rear pneumatic wheel was raised about an inch off the ground so that the main friction between the belt and the pavement now occurs only under the

front pneumatic wheel. The belt has sufficient sag so that it lies on the pavement for most of the space between the wheels, but the lateral force generation capability is substantially reduced. This modification was found to permit the vehicle to be towed at speeds up to 30 miles per hour with the driver intentionally swerving in the lane and the belt remained on the pulleys. The instrument carriage was not mounted on the belt during this test.

However, this problem is not considered to be satisfactorily solved at this time and is a weak point in the belt system which is currently installed on the test model. It is anticipated that the belt and its suspension will have to be modified to provide reliable operation without the danger of losing the belt. The modification that appears to be most promising at this time is to secure a series of lugs to the inside surface of the belt, making it similar to a large vee belt. The crowned pulleys and pneumatic wheels would be replaced with a configuration suitable for accepting the vee belt. Several industrial type snow vehicles are equipped with tracks of this type and appear to have been proven reliable.

The vehicle has been built with sufficient space and versatility so that modifications of this type can be tried.

## CHAPTER V

DISCUSSION - INSTRUMENT CARRIAGE DESIGN

A drawing of the instrument carriage is shown in Fig. V-1. The carriage consists of a frame holding two transducers spaced 18" apart and mounted in supports in such a way that when the carriage is placed on the ground the transducers are sufficiently decoupled from the carriage frame so that shock waves are not transmitted to the transducers through the carriage but only through the pavement. In addition to the two transducers, the carriage contains a hammering pin which, when struck by the hammer mounted on the vehicle inner frame, produces the impulse necessary to determine the Impulse Index.

The carriage is secured to the belt using the carriage support assembly shown in Fig. V-2. Part B of the support assembly is secured to the carriage and Part A is secured to the belt. Part B is an inverted cone which cannot escape from the retaining ring of Part A. The retaining ring is attached to Part A by a pivot bearing. This assures that Part B and the carriage always hang in a downward position, even when Part A inverts on the upper portion of its travel with the belt. When the carriage is on the upper part of the belt, the weight of the carriage forces the cone downward into the retaining ring so that it is centered in position. The advance of the vehicle causes the carriage to be lowered to the pavement. When the carriage contacts the pavement, the retaining ring continues downward a little further and Parts A and B of the support separate and develop a clearance of about an inch. This clearance is to allow for a limited amount of slippage of the belt with

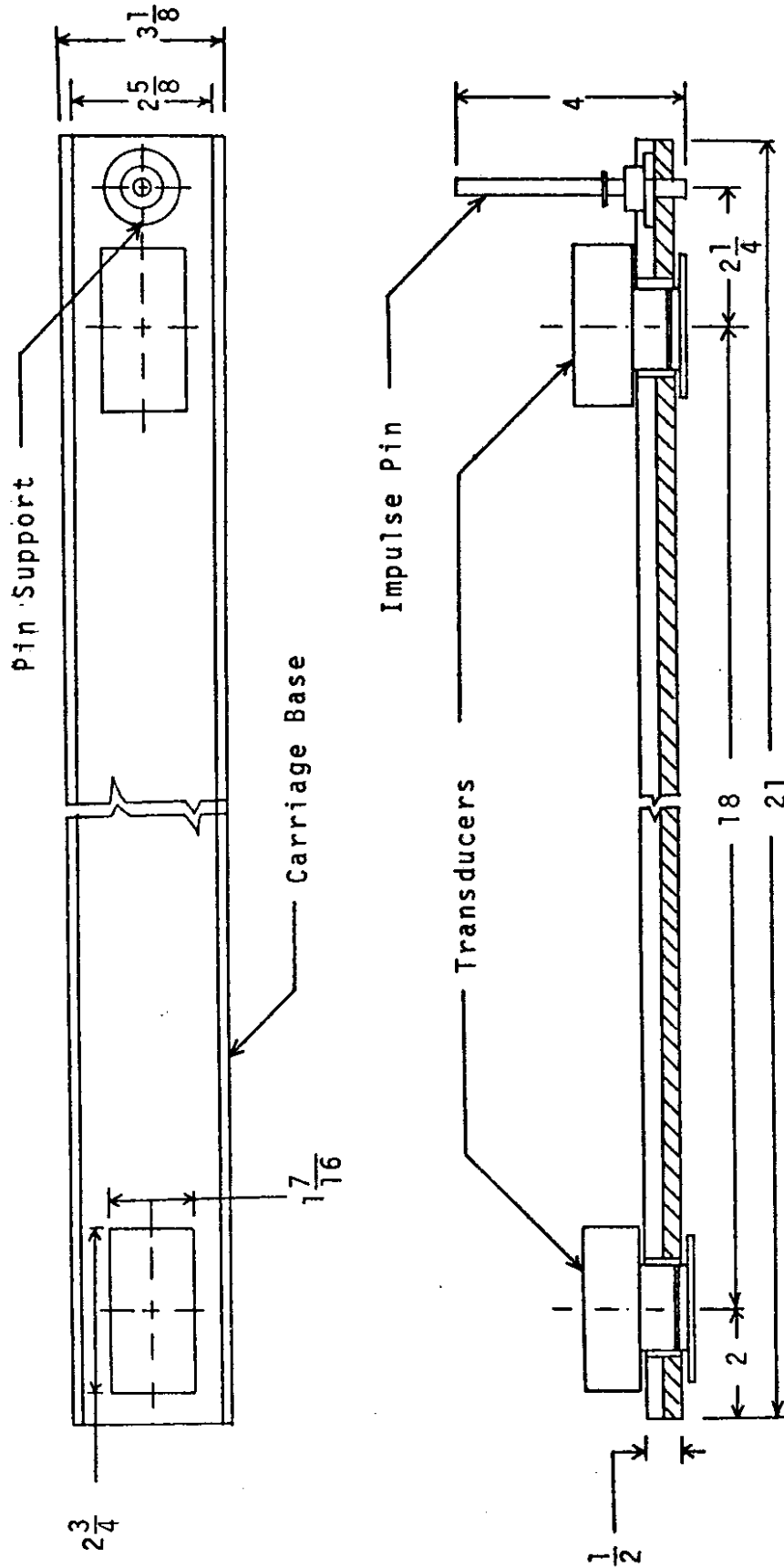

FIGURE V-1

Carriage Assembly

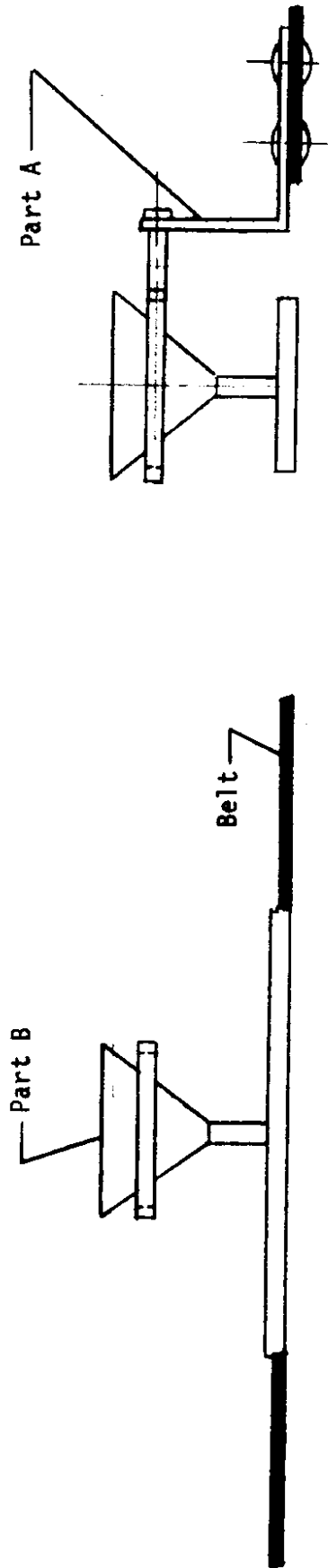
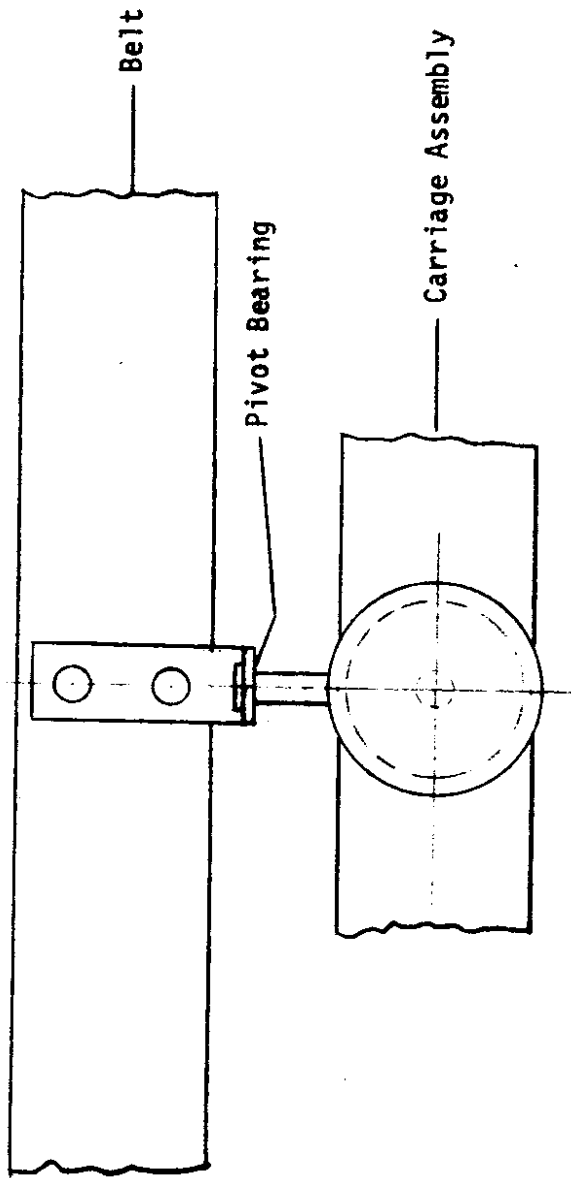

FIGURE V-2  
Carriage Support Assembly

respect to the pavement without causing the carriage to be dragged along the pavement. The carriage is then setting on the pavement completely out of physical contact with the rest of the vehicle until the vehicle advances to the point where the rear pneumatic tire catches up to the carriage and it is again lifted from the ground by the retaining ring.

With the existing configuration, the only method available to acquire the electrical signals from the transducers is by means of a coiled telephone type wire with one end attached to the carriage and the other end attached to the vehicle frame. Such a method is simple and does perform at limited speeds, however, there is a better way to accomplish the desired result. The major emphasis of this present phase of the project has been on developing the model to acquire the information to design a prototype, and it was realized early that the biggest problem would be the mechanical action to gently set down the instrument package, leave it on the pavement for a short period of time, and then retrieve it while the vehicle maintains forward velocity down the highway. Other techniques of acquiring the signals have been thought of, and it is anticipated that such development would occur in a future project.

Sliding electrical contacts and slip rings have been suggested, however, the noise problem associated with such devices is not to be lightly dismissed. It appears that the most satisfactory method of delivering the signals from the transducers to the frame of the vehicle will be with the use of small telemetering type transmitters mounted with the transducers, and a receiver on the frame of the vehicle, thus eliminating the problem of wires between the two units.



The use of telemetering would have another great advantage over the present system. The transducer mounts could be secured in the belt instead of cantilevered out as with the present carriage. The modified belt and suspension as described in Chapter IV would provide sufficient space in the vee part of the belt to embed the transducers, hammering pin, and telemetering transmitters and the added symmetry of the system would make the mechanical problems easier to handle. It is likely that this is the approach that will ultimately provide the most satisfactory solution to the problem.



## CHAPTER VI

DISCUSSION - THE IMPULSE HAMMER

When the instrument carriage is placed on the pavement, some amount of time must be permitted to elapse to allow the transducers to return to their relaxed condition. It is not known at this time just how much time must elapse, but flexible provision is made for it by mounting the hammer several feet aft of the front pneumatic wheel. When the hammering pin on the carriage is at a point immediately under the hammer, a microswitch operates air valves which cause the hammer to operate and strike the pin. Air for this model is supplied from an air tank. The hammer has a broad head so that it will hit the pin even if the carriage is not quite in the anticipated position.

The hammer is affixed to the inner frame of the vehicle and employs a Bacharach type of linkage to give a nearly straight line motion of the hammer head.

The hammering pin is the highest point on the carriage and the stroke of the hammer is restricted so that there is no danger to the carriage even if the hammer head should accidentally miss the hammering pin.

The work done to date using the Impulse Index has indicated that the exact amount of energy in the hammer blow is not very critical regarding theoretical limits of the Impulse Index technique. There is, however, a relationship between the hammer energy and the signal to noise ratio of the transducer outputs, along with the physical size of the transducers, which in turn is expected to effect the required settling time. Consequently, the hammer is designed to have an adjustable energy strike.

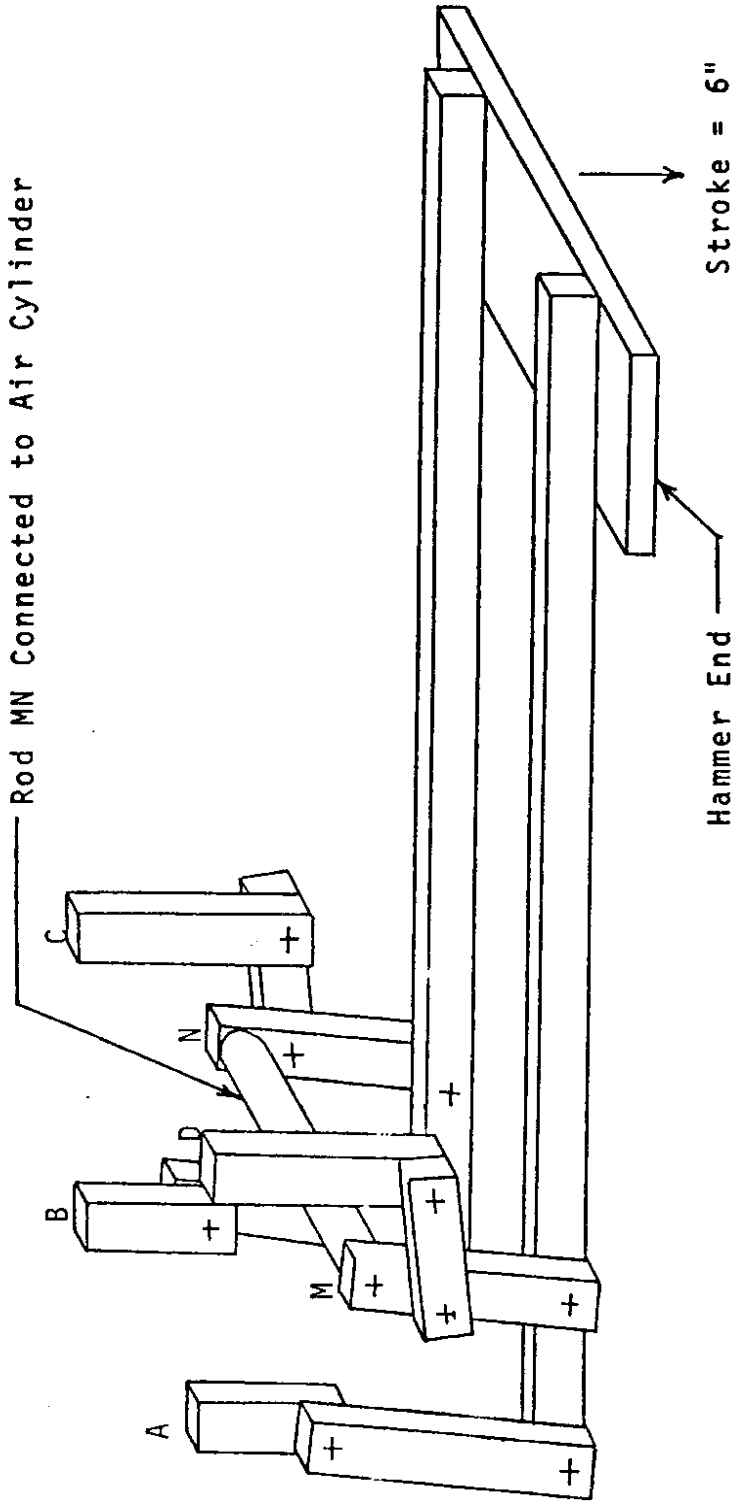

A, B, C, D are fixed points

FIGURE VI-1

Pneumatic Hammer Linkage (Bacharach Mechanism)

## CHAPTER VII

APPLICATIONS AND EXHIBITS

The following series of photographs are intended to pictorially display the action of the system presently installed on the test model. Fig. VII-1 is a view of the vehicle with the inner frame raised. Figs. VII-2, VII-3, and VII-4 are a sequence indicating the manner in which the instrument carriage is set on the pavement as the vehicle is advanced. Fig. VII-5, shows the hammer in the strike position. As the vehicle continues down the road, the carriage is lifted off the pavement at the rear of the vehicle and transported to the front where the action repeats.

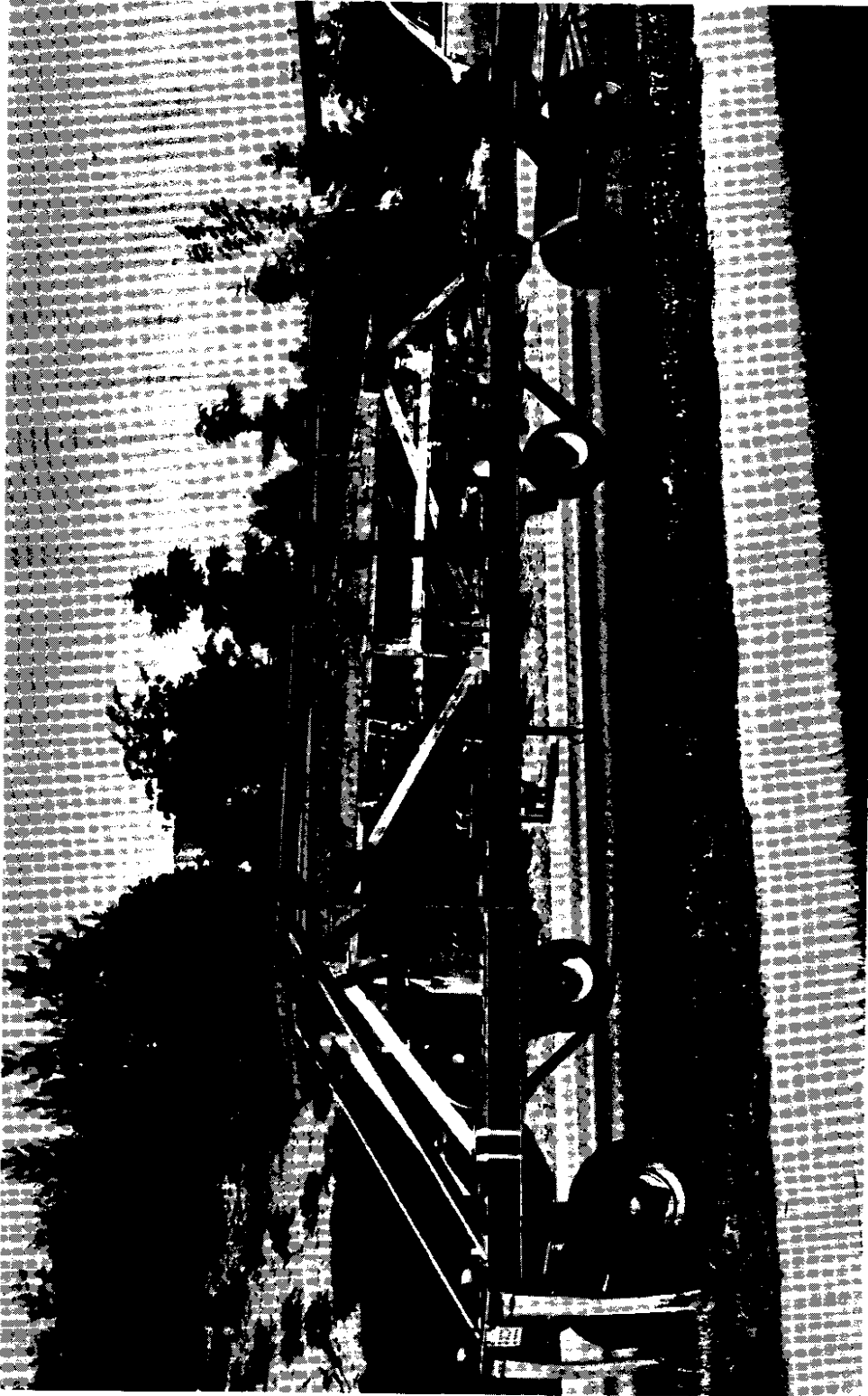

FIGURE VII-1

Test Model Trailer Vehicle

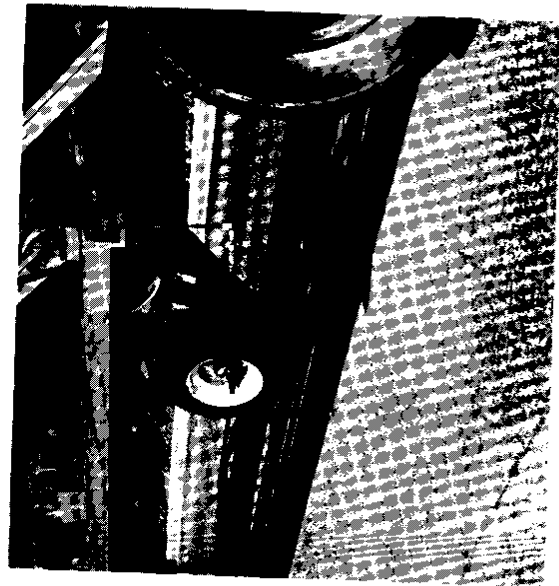

FIGURE VII-2

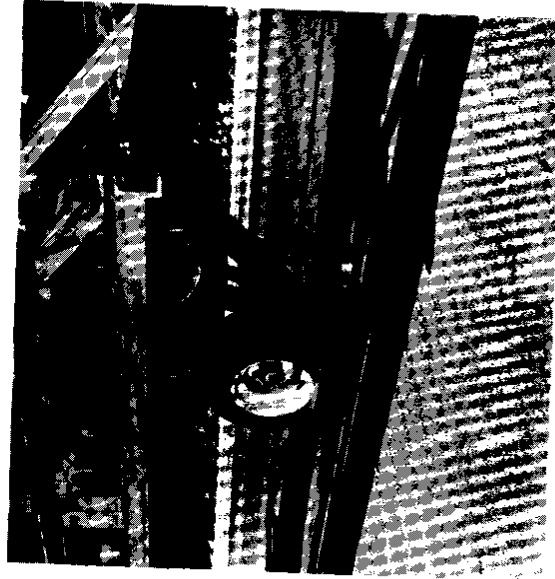

FIGURE VII-3

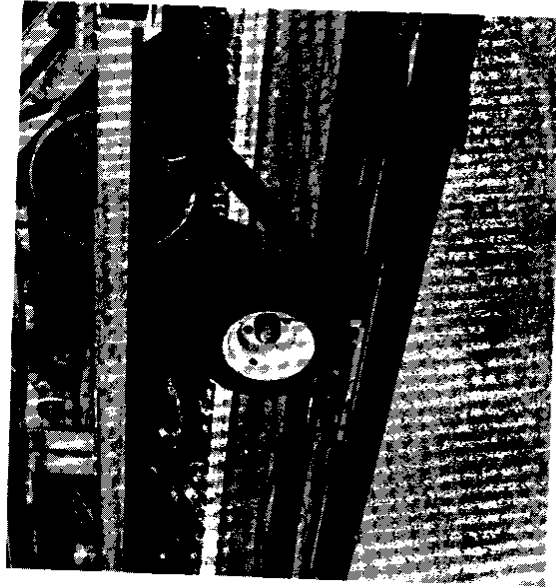

FIGURE VII-4

Sequence Indicating Manner in which Instrument Carriage is Set  
on Pavement



FIGURE VII-5

The Impulse Hammer & Carriage