

Transmittal Number PT 18-056	Date July 2018
Publication Distribution To: <i>Design Manual</i> Holders	
Publication Title <i>Design Manual</i> – July 2018	Publication Number M 22-01.15
Originating Organization WSDOT Development Division, Design Office – Design Policy, Standards, and Safety Research Section	

## Remarks and Instructions

### *What's changed in the Design Manual for July 2018?*

See the summary of revisions beginning on Page 3.

### *How do you stay connected to current design policy?*

It's the designer's responsibility to apply current design policy when developing transportation projects at WSDOT. The best way to know what's current is to reference the manual online.

Access the current electronic WSDOT *Design Manual*, the latest revision package, and individual chapters at: [www.wsdot.wa.gov/publications/manuals/m22-01.htm](http://www.wsdot.wa.gov/publications/manuals/m22-01.htm)

*We're ready to help. If you have comments or questions about the Design Manual, please don't hesitate to contact us.*

Area of Practice	Your Contacts		
<b>Geometric Design, Roadside Safety and Traffic Barriers</b>	Jeff Petterson	360-705-7246	<a href="mailto:PETTERJ@wsdot.wa.gov">PETTERJ@wsdot.wa.gov</a>
<b>General Guidance and Support</b>	Chris Schroedel	360-705-7299	<a href="mailto:SCHROEC@wsdot.wa.gov">SCHROEC@wsdot.wa.gov</a>
	John Donahue	360-705-7952	<a href="mailto:DONAHJO@wsdot.wa.gov">DONAHJO@wsdot.wa.gov</a>

### *To get the latest information on individual WSDOT publications:*

Sign up for email updates at: [www.wsdot.wa.gov/publications/manuals/](http://www.wsdot.wa.gov/publications/manuals/)

HQ Design Office Signature <b>/s/ Jeff Carpenter</b>	Phone Number 360-705-7821
---	------------------------------

## Remove/Insert instructions for those who maintain a printed manual

**NOTE:** Also replace the Title Page

CHAPTER/SECTION		REMOVE PAGES	INSERT PAGES
Contents/Exhibits		Entire Contents	Entire Contents
100	Manual Description	Entire chapter	Entire chapter
300	Design Documentation, Approval, and Process Review	Entire chapter	Entire chapter
310	Value Engineering	310-3&4	310-3&4
320	Traffic Analysis	Entire chapter	Entire chapter
321	Sustainable Safety Analysis	Entire chapter	Entire chapter
530	Limited Access Control	Entire chapter	Entire chapter
550	Freeway Access Revision	Entire chapter	Entire chapter
1040	Illumination	1040-3-6; 1040-9&10; 1040-13&14; 1040-39&40;	1040-3-6; 1040-9&10; 1040-13&14; 1040-39&40;
1101	Need Identification	Entire chapter	Entire chapter
1102	Context Identification	Entire chapter	Entire chapter
1103	Design Control Selection	Entire chapter	Entire chapter
1120	Preservation Projects	Entire chapter	Entire chapter
1239	Geometric Cross Section – Shoulders, Side Slopes, Curbs, and Medians	1239-7&8	1239-7&8
1300	Intersection Control Type	Entire chapter	Entire chapter
1320	Roundabouts	1320-1&2; 1320-19&20	1320-1&2; 1320-19&20
1330	Traffic Control Signals	Entire chapter	Entire chapter
1360	Interchanges	1360-1&2	1360-1&2
1410	High-Occupancy Vehicle Facilities	Entire chapter	Entire chapter
1420	HOV Direct Access	1420-1&2; 1420-19&20	1420-1&2; 1420-19&20
1510	Pedestrian Facilities	Entire chapter	Entire chapter
1600	Roadside Safety	Entire chapter	Entire chapter
1610	Traffic Barriers	Entire chapter	Entire chapter
1620	Impact Attenuator Systems	Entire chapter	Entire chapter
1720	Weigh Sites	1720-1-4	1720-1-4
Glossary		Entire Glossary	Entire Glossary

### About revision marks and footer dates:

- A new date appears in the footer of each page that has changes.
- Changes include inserted or deleted content and existing content that shifts to a new page.
- Substantially rewritten chapters will have no revision marks. This is the case with many chapters this publication.
- In some cases, just a page of a chapter changed with a spot revision, such as a correction or new chapter reference.

## Summary of *Design Manual Changes* – July 2018 (Revisions merit careful study beyond this summary)

### Highlights of the More Substantial Revisions

#### **Chapter 530 Limited Access Control**

- Defined “access breaks” and “inner corridor access”
- Added language about hearing waivers to section 530.02(2)(a)
- Added new Exhibit 530-1f showing Diverging Diamond Interchange and minimum L/A control lengths on cross road; updated section 530.03(3) language to include this new exhibit
- Eliminated confusing / unrepresentative examples of changes to limited access control
- Reference new electronic access request checklist and submittal procedure detailed on Access and Hearings website: <http://www.wsdot.wa.gov/Design/accessandhearings/>
- Added multimodal text in many sections.

#### **Chapter 550 Freeway Access Revision**

- Provides instruction for the process, reporting, and documentation requirements to revise interchange access on freeways in Washington State. Highlights of the revised chapter include:
- Aligns updated Federal policy with WSDOT Practical Solutions approach;
- Interchange Justification Report is now called Access Revision Report (ARR);
- Provides steps in the process to prepare a Non-Access Feasibility study, and ARR
- Prior to preparing the ARR, a Non-Access Feasibility Study is conducted to seek improvements that meet performance needs.
- If the Feasibility study does not resolve performance need, the ARR is prepared to include and analyze on-system freeway improvements.
- The required NEPA/SEPA document is needed before final approval of an ARR.
- Provides details about environmental, planning disciplines, outputs and engagement;
- Presents typical members and expectations for Executive and Support teams;
- Chapter 550 Policy applies only to freeways.

#### **Chapter 1120 Preservation Projects**

- Clarifying how and where to rehabilitate rumble strips
- Provide consistency in measuring and using guardrail height
- Provide consistency in treating breakaway cable terminals

#### **Chapter 1300 Intersection Control Type**

- With this revision the term Intersection Control Analysis (ICA) is changing to Intersection Control Evaluation (ICE)
- 1300.01 - ICE is working document to ensure scope and schedule are compatible with intersection type.
- 1300.05 - when ICE is/ is not required; safety and operational considerations when rechannelize existing pavement.
- 1300.05(1) - Clarifications and instruction added to procedures section for safety analysis and alternatives evaluation.
- Other minor word changes.

#### **Chapter 1330 Traffic Control Signals**

- 1330.02(1)(a) - Minor revision for Warrant F support data.

- 1330.02(2) - Revised the threshold for city population to 27,500 (RCW 47.24.020 was revised in the 2018 Legislative session).
- 1330.03(3) - Transferred information to Section 1510.12.
- Exhibit 1330-8 - Minor revisions made.
- 1330.04(3) - Added display information for permissive right turns.
- 1330.04(4) - Minor revisions made.
- 1330.04(4)(a) - Revisions made to accessible pedestrian signals, including guidance transferred from 1510.12(3).
- 1330.04(5) - Revisions made for mast arm signal standards and foundation design.
- 1330.04(5)(c) - Minor revisions made.
- 1330.06 - Minor revisions made.
- 1330.6(5) - Added a new section for APS.
- Other minor revisions and re-dated all pages as 2018.

#### **Chapter 1510 Traffic Control Signals**

- 1510.05 (2) - Minor revision to MEF documentation.
- 1510.05(2)(a) - A new section was added to provide clarification on when to address accessibility at signalized intersections.
- 1510.09(2)(b) - Clarification on maximum running slope of a ramp.
- 1510.10(2)(b) - Revised the threshold for city population to 27,500 (RCW 47.24.020 was revised in the 2018 Legislative session).
- 1510.12 - Information transferred from Chapter 1330.
- 1510.12(1)(a) - Moved pertinent information from 1510.12(3) to this section.
- 1510.12(1)(b) - Guidance reorganized and rewritten and revised exhibits 1510-23, 24a, 24b.
- 1510.12(1)(c) - Guidance rewritten and revised exhibit 1510-25.
- 1510.12(2) - Moved guidance for when Accessible Pedestrian Signals (APS) are required to be installed to Chapter 1330.
- Other minor revisions and re-dated all pages as 2018.

#### **Chapter 1600 Roadside Safety**

- Update and clarify process for addressing inadequate pavement structure in rumble strip installation
- Rumble stripes added
- Low noise rumble strips added
- Breakaway light standards clarified
- Rumble strip criteria reorganized and clarified

#### **Chapter 1610 Traffic Barriers**

- Extending existing runs of older style guardrail (Type 1, Type 2, Type 3, Type 4) is no longer allowed. Extensions now must use MASH compliant systems (such as Type 31 guardrail).
- Moved remaining minor information on transitions and anchors for (Old) Type 1 guardrail to the Roadside Safety Design webpage. Note that associated Standard Plans for Type 1 guardrail anchors and transitions will be moved to the Plan Sheet Library.
- 1610.03(5) - Clarified the definition of length of need.
- 1610.04(6) - Added a new shorter length, low-speed transition and provided additional guidance regarding other Type 31 transitions. A new Standard Plan C-25.30, Type 24 Transition (Low Speed), will be published in July.
- 1610.04(7)(a) - Eliminated placement case 6 (no corresponding case in Std. Plans).
- 1610.06(1) - Made F-shape barrier the preferred shape (over New Jersey shape) for precast non-embedded concrete barrier (F-shape is MASH compliant). New Jersey shape is still allowed.



- Revised Exhibit 1610-13 by removing Type 1 guardrail transitions and added the new Type 24 Transition to the table.
- 1610.07 - Updated to reflect 42" min. bridge rail height (for fall protection), and stated the long-standing Test Level 4 requirement for bridge rail.
- 1610.07(1)(b) - Eliminated language regarding I-2 Bridge Rail upgrades program as recommended by BSO.
- Other minor revisions made.

#### **Chapter 1620 Impact Attenuator Systems**

- Moved detailed information regarding specific impact attenuator systems to the Roadside Safety Design website.
- A new web-based Attenuator Selection Template (documentation tool) has been developed to replace the detailed exhibits showing attenuator system design information.
- Phased out sand barrels as there are currently no MASH compliant systems available.
- Other minor revisions made.

### Highlights of Other Chapter Revisions

#### **Chapter 100 Manual Description**

- Minor updates to division and chapter names and descriptions.

#### **Chapter 300 Design Documentation, Approval, and Process Review**

- Minor changes/clarifications to lists of items included at Design Approval and Project Development Approval.
- Updated change management text in 300.06(1)(a) Project Definition according to the Program Management Manual
- Exhibit 300-2 Approvals: changed Interchange Justification Report to Access Revision Report per changes to Chapter 550; removed Project Change Request Form from table, per changes and new Program Management Manual.

#### **Chapter 310 Value Engineering**

- Edited for change in acronyms, replace IJR with ARR, replace ICA with ICE, and insert WSDOT in place of text.

#### **Chapter 320 Traffic Analysis**

- Edited for change in acronyms, replace IJR with ARR, replace ICA with ICE, and insert WSDOT in place of text.

#### **Chapter 321 Sustainable Safety Analysis**

- Minor text edits

#### **Chapter 1040 Illumination**

- Clarified single light standard requirements, particularly for ramp terminals
- Clarified definition of transit flyer stops
- Clarified requirements for slip bases (concurrent with chapter 1600 revisions)
- Updated population threshold to 27,500 per recent change in state law (RCW 47.24.020).

#### **Chapter 1101 Need Identification**

- minor text edits

#### **Chapter 1102 Context Identification**

- 1102.01 and 1102.05(2) - Updated reference to NCHRP Report 855 – An Expanded Functional Classification System for Highways and Streets.

- 1102.02 - Clarified that for freeways, Section 2 of the Basis of Design is used only to report the rural or urban land use designation.
- 1102.04 - Added reference and link to the Context and Modal Accommodation Report template, which is used to document initial context determination on the Basis of Design.

### **Chapter 1103 Design Control Selection**

- 1103.03 - Updated reference to NCHRP Report 855 – An Expanded Functional Classification System for Highways and Streets.
- 1103.02(2) - Provided optional way to use local agency information to select forecast or horizon year for purposes of determining modal accommodation level; added reference to WSDOT’s Context and Modal Accommodation Report.
- 1103.03(3) - Added reference to WSDOT’s Context and Modal Accommodation Report and Basis of Design, emphasis to engage project advisory team.
- 1103.08(2) - Added WSDOT Design Support website link, to emphasize downloading the Context and Modal Accommodation Report and BOD; added reference and link to NCHRP Report 855.

### **Chapter 1239 Geometric Cross Section – Shoulders, Side Slopes, Curbs, and Medians**

- Incorporated Technical Errata for Exhibit 1239-4 which instructs to see Hydraulics Manual for ditch depth.

### **Chapter 1320 Roundabouts**

- 1320.11 – Correct typo, “state” in place of “Stat”
- 1320.04(5) – Correct typo, replace “titled” with “tilted”
- Edited for change in acronyms, replace IJR with ARR, replace ICA with ICE, and insert WSDOT in place of text.

### **Chapter 1360 Interchanges**

- Edited for change in acronyms, replace IJR with ARR, replace ICA with ICE, and insert WSDOT in place of text.

### **Chapter 1410 High-Occupancy Vehicle Facilities**

- Actual revisions are only in Sections 1410.02(3)(e) and 1410.04(4)(e). The revisions provide direction for HOV by-pass ramp metering of on-ramps and are shown with sidebars and underlines.
- Entire chapter reformatted to be consistent with current Design Manual styles and sections.

### **Chapter 1420 HOV Direct Access**

- Edited for change in acronyms, replace IJR with ARR, replace ICA with ICE, and insert WSDOT in place of text.

### **Chapter 1720 Weigh Sites**

- Edited for change in acronyms, replace IJR with ARR, replace ICA with ICE, insert WSDOT in place of text.



# Design Manual

M 22-01.15

July 2018

- Division 1 – General Information
- Division 2 – Hearings, Environmental, and Permits
- Division 3 – Project Documentation
- Division 4 – Surveying
- Division 5 – Right of Way and Access Control
- Division 6 – Soils and Paving
- Division 7 – Structures
- Division 8 – Hydraulics
- Division 9 – Roadside Development
- Division 10 – Traffic Safety Elements
- Division 11 – Practical Design
- Division 12 – Geometrics
- Division 13 – Intersections and Interchanges
- Division 14 – HOV and Transit
- Division 15 – Pedestrian and Bicycle Facilities
- Division 16 – Roadside Safety Elements
- Division 17 – Roadside Facilities

**Engineering and Regional Operations**

Development Division, Design Office

## **Americans with Disabilities Act (ADA) Information**

Materials can be made available in an alternative format by emailing the WSDOT Diversity/ADA Affairs Team at [wsdotada@wsdot.wa.gov](mailto:wsdotada@wsdot.wa.gov) or by calling toll free: 855-362-4ADA (4232). Persons who are deaf or hard of hearing may contact that number via the Washington Relay Service at 7-1-1.

## **Title VI Notice to Public**

It is Washington State Department of Transportation (WSDOT) policy to ensure no person shall, on the grounds of race, color, national origin, or sex, as provided by Title VI of the Civil Rights Act of 1964, be excluded from participation in, be denied the benefits of, or be otherwise discriminated against under any of its federally funded programs and activities. Any person who believes his/her Title VI protection has been violated may file a complaint with WSDOT's Office of Equal Opportunity (OEO). For Title VI complaint forms and advice, please contact OEO's Title VI Coordinator at 360-705-7082 or 509-324-6018.

To get the latest information on individual WSDOT publications, sign up for email updates at:

 [www.wsdot.wa.gov/publications/manuals](http://www.wsdot.wa.gov/publications/manuals)

## Division 1 – General Information

- Chapter 100 Manual Description**
- 100.01 Purpose
  - 100.02 Presentation and Revisions
  - 100.03 Practical Solutions
  - 100.04 Manual Applications
  - 100.05 Manual Use
  - 100.06 Manual Organization
- Chapter 110 Design-Build Projects**
- 110.01 General
  - 110.02 Terminology and Language Used
  - 110.03 Design and Documentation Responsibility
  - 110.04 References

## Division 2 – Hearings, Environmental, and Permits

- Chapter 210 Public Involvement and Hearings**
- 210.01 General
  - 210.02 References
  - 210.03 Definitions
  - 210.04 Public Involvement
  - 210.05 Public Hearings
  - 210.06 Environmental Hearing
  - 210.07 Corridor Hearing
  - 210.08 Design Hearing
  - 210.09 Limited Access Hearing
  - 210.10 Combined Hearings
  - 210.11 Administrative Appeal Hearing
  - 210.12 Follow-Up Hearing
  - 210.13 Documentation
- Chapter 225 Environmental Coordination**
- 225.01 General
  - 225.02 References
  - 225.03 Determining the Environmental Documentation
  - 225.04 Identifying the Project Classification
  - 225.05 Environmental Commitment File
  - 225.06 Environmental Permits and Approvals
  - 225.07 Documentation

## Division 3 – Project Documentation

- Chapter 300 Design Documentation, Approval, and Process Review**
- 300.01 General
  - 300.02 WSDOT Project Delivery
  - 300.03 Design Documentation and Records Retention Policy
  - 300.04 Project Design Approvals
  - 300.05 FHWA Oversight and Approvals
  - 300.06 Project Documents and Approvals
  - 300.07 Process Review
  - 300.08 References

<b>Chapter 301</b>	<b>Design and Maintenance Coordination</b>
301.01	Introduction
301.02	Communication
301.03	Incorporating Maintenance Considerations in Design
301.04	Documentation
301.05	References
<b>Chapter 305</b>	<b>Project Management</b>
305.01	Introduction
305.02	Project Management
305.03	Project Management Tools
305.04	Cost and Risk Management
305.05	References
<b>Chapter 310</b>	<b>Value Engineering</b>
310.01	General
310.02	Statewide VE Program
310.03	VE Procedure
310.04	Value Engineering Job Plan
310.05	Project Management Accountability
310.06	Documentation
310.07	References
<b>Chapter 320</b>	<b>Traffic Analysis</b>
320.01	General
320.02	Design Year and Forecasting Considerations
320.03	Traffic Analysis Software
320.04	Travel Demand Forecasting
320.05	Traffic Impact Analysis (TIA)
320.06	TIA Scope
320.07	TIA Methods and Assumptions Document
320.08	TIA Methodologies
320.09	TIA Mitigation Measures
320.10	TIA Report
320.11	References
<b>Chapter 321</b>	<b>Sustainable Safety Analysis</b>
321.01	Sustainable Safety Related Policy
321.02	HQ Safety Technical Group
321.03	Project Related Safety Analysis
321.04	Stand Alone Safety Analysis
321.05	Reports and Documentation
321.06	References

## **Division 4 – Surveying**

<b>Chapter 400</b>	<b>Surveying and Mapping</b>
400.01	General
400.02	References
400.03	Procedures
400.04	Datums
400.05	Global Positioning System
400.06	WSDOT Survey Monument Database
400.07	Geographic Information System
400.08	Photogrammetric Surveys
400.09	Documentation

**Chapter 410 Monumentation**

- 410.01 General
- 410.02 References
- 410.03 Control Monuments
- 410.04 Alignment Monuments
- 410.05 Property Corners
- 410.06 Other Monuments
- 410.07 Filing Requirements
- 410.08 Documentation

**Division 5 – Right of Way and Access Control**

**Chapter 510 Right of Way Considerations**

- 510.01 General
- 510.02 Special Features
- 510.03 Easements and Permits
- 510.04 Programming for Funds
- 510.05 Appraisal and Acquisition
- 510.06 Transactions
- 510.07 Documentation
- 510.08 References

**Chapter 520 Access Control**

- 520.01 General
- 520.02 References
- 520.03 Definitions
- 520.04 Vocabulary

**Chapter 530 Limited Access Control**

- 530.01 General
- 530.02 Achieving Limited Access
- 530.03 Full Control (Most Restrictive)
- 530.04 Partial Control
- 530.05 Modified Control (Least Restrictive)
- 530.06 Access Approaches
- 530.07 Frontage Roads
- 530.08 Turnbacks
- 530.09 Adjacent Railroads
- 530.10 Access Breaks and Inner Corridor Access
- 530.11 Documentation

**Chapter 540 Managed Access Control**

- 540.01 General
- 540.02 Design Considerations
- 540.03 Managed Access Highway Classes
- 540.04 Corner Clearance Criteria
- 540.05 Access Connection Categories
- 540.06 Access Connection Permit
- 540.07 Permitting and Design Documentation
- 540.08 Other Considerations
- 540.09 Preconstruction Conference
- 540.10 Adjudicative Proceedings
- 540.11 Documentation
- 540.12 References

**Chapter 550 Freeway Access Revision**  
550.01 Overview  
550.02 Freeway Access Policy  
550.03 Access Revision Analysis Process  
550.04 Support Teams  
550.05 Non-Access Feasibility Study  
550.06 Access Revision Report Process  
550.07 Documentation  
550.08 References

**Chapter 560 Fencing**  
560.01 General  
560.02 Design Criteria  
560.03 Fencing Types  
560.04 Gates  
560.05 Procedure  
560.06 Documentation  
560.07 References

## **Division 6 – Soils and Paving**

**Chapter 610 Investigation of Soils, Rock, and Surfacing Materials**  
610.01 General  
610.02 References  
610.03 Materials Sources  
610.04 Geotechnical Investigation, Design, and Reporting  
610.05 Use of Geotechnical Consultants  
610.06 Geotechnical Work by Others  
610.07 Surfacing Report  
610.08 Documentation

**Chapter 620 Design of Pavement Structure**  
620.01 General  
620.02 Estimating Tables

**Chapter 630 Geosynthetics**  
630.01 General  
630.02 References  
630.03 Geosynthetic Types and Characteristics  
630.04 Geosynthetic Function Definitions and Applications  
630.05 Design Approach for Geosynthetics  
630.06 Design Responsibility  
630.07 Documentation

## **Division 7 – Structures**

**Chapter 700 Project Development Roles and Responsibilities for Projects With Structures**

700.01 General  
700.02 Procedures

**Chapter 710 Site Data for Structures**

710.01 General  
710.02 Required Data for All Structures  
710.03 Additional Data for Waterway Crossings (Bridges and Buried Structures)  
710.04 Additional Data for Grade Separations



- 710.05 Additional Data for Widening
- 710.06 Documentation
- 710.07 References

**Chapter 720 Bridges**

- 720.01 General
- 720.02 Bridge Locations
- 720.03 Bridge Site Design Elements
- 720.04 Documentation
- 720.05 References

**Chapter 730 Retaining Walls and Steep Reinforced Slopes**

- 730.01 General
- 730.02 References
- 730.03 Design Principles
- 730.04 Design Requirements
- 730.05 Guidelines for Wall/Slope Selection
- 730.06 Design Responsibility and Process
- 730.07 Documentation

**Chapter 740 Noise Barriers**

- 740.01 General
- 740.02 Design
- 740.03 Procedures
- 740.04 Documentation
- 740.05 References

**Division 8 – Hydraulics**

**Chapter 800 Hydraulic Design**

- 800.01 General
- 800.02 References
- 800.03 Hydraulic Considerations
- 800.04 Safety Considerations
- 800.05 Design Responsibility
- 800.06 Documentation

**Division 9 – Roadside Development**

**Chapter 900 Roadsides**

- 900.01 General
- 900.02 References
- 900.03 Project Development
- 900.04 Documentation

**Chapter 950 Public Art**

- 950.01 General
- 950.02 References
- 950.03 Standard Architectural Design
- 950.04 Criteria for Public Art
- 950.05 Process and Project Delivery Timing
- 950.06 Approvals
- 950.07 Documentation

## **Division 10 – Traffic Safety Elements**

### **Chapter 1010 Work Zone Safety and Mobility**

- 1010.01 General
- 1010.02 Definitions
- 1010.03 Work Zone Safety and Mobility
- 1010.04 Transportation Management Plans and Significant Projects
- 1010.05 Developing TMP Strategies
- 1010.06 Capacity Analysis
- 1010.07 Work Zone Design
- 1010.08 Temporary Traffic Control Devices
- 1010.09 Positive Protection Devices
- 1010.10 Other Traffic Control Devices or Features
- 1010.11 Traffic Control Plan Development and PS&E
- 1010.12 Training and Resources
- 1010.13 Documentation
- 1010.14 References

### **Chapter 1020 Signing**

- 1020.01 General
- 1020.02 Design Components
- 1020.03 Overhead Installation
- 1020.04 State Highway Route Numbers
- 1020.05 Mileposts
- 1020.06 Guide Sign Plan
- 1020.07 Documentation
- 1020.08 References

### **Chapter 1030 Delineation**

- 1030.01 General
- 1030.02 Definitions
- 1030.03 Pavement Markings
- 1030.04 Guideposts
- 1030.05 Barrier Delineation
- 1030.06 Object Markers
- 1030.07 Documentation
- 1030.08 References

### **Chapter 1040 Illumination**

- 1040.01 General
- 1040.02 Definitions
- 1040.03 Design Considerations
- 1040.04 Required Illumination
- 1040.05 Additional Illumination
- 1040.06 Design Criteria
- 1040.07 Documentation
- 1040.08 References

### **Chapter 1050 Intelligent Transportation Systems**

- 1050.01 General
- 1050.02 References
- 1050.03 Systems Engineering
- 1050.04 FHWA Washington Division ITS Project Contracting Guidance
- 1050.05 Documentation

## Division 11 – Practical Design

### Chapter 1100 Practical Design

- 1100.01 General
- 1100.02 Practical Design Procedure
- 1100.03 Community Engagement
- 1100.04 Advisory Team
- 1100.05 Need and Performance Identification
- 1100.06 Context Identification
- 1100.07 Design Control Selection
- 1100.08 Alternative Formulation and Evaluation
- 1100.09 Design Element Selection and Dimensions
- 1100.10 Documentation Tools
- 1100.11 References

### Chapter 1101 Need Identification

- 1101.01 General
- 1101.02 Baseline Needs
- 1101.03 Contextual Needs
- 1101.04 Contributing Factors Analysis
- 1101.05 Project Need Statement
- 1101.06 Documentation
- 1101.07 References

### Chapter 1102 Context Determination

- 1102.01 General Overview
- 1102.02 Land Use Context
- 1102.03 Transportation Context
- 1102.04 Documentation
- 1102.05 References

### Chapter 1103 Design Control Selection

- 1103.01 General Overview
- 1103.02 Control: Design Year
- 1103.03 Control: Modal Priority
- 1103.04 Control: Access Control
- 1103.05 Control: Design Speed
- 1103.06 Control: Terrain Classification
- 1103.07 Documentation
- 1103.08 References

### Chapter 1104 Alternatives Analysis

- 1104.01 General
- 1104.02 Alternative Solution Formulation
- 1104.03 Alternative Solution Evaluation
- 1104.04 Documentation
- 1104.05 References

### Chapter 1105 Design Element Selection

- 1105.01 General
- 1105.02 Selecting Design Elements
- 1105.03 Related Elements
- 1105.04 Documentation
- 1105.05 References

**Chapter 1106 Design Element Dimensions**

- 1106.01 General
- 1106.02 Choosing Dimensions
- 1106.03 The Mode/Function/Performance Approach
- 1106.04 Design Up Method
- 1106.05 Quantitative Analysis Methods and Tools
- 1106.06 Documenting Dimensions
- 1106.07 Design Analysis
- 1106.08 References

**Chapter 1120 Preservation Projects**

- 1120.01 General
- 1120.02 Structures Preservation (P2) and Other Facilities (P3)
- 1120.03 Roadway Preservation (P1)

**Division 12 – Geometrics**

**Chapter 1210 Geometric Plan Elements**

- 1210.01 General
- 1210.02 Horizontal Alignment
- 1210.03 Distribution Facilities
- 1210.04 Number of Lanes and Arrangement
- 1210.05 Pavement Transitions
- 1210.06 Procedures
- 1210.07 Documentation
- 1210.08 References

**Chapter 1220 Geometric Profile Elements**

- 1220.01 General
- 1220.02 Vertical Alignment
- 1220.03 Coordination of Vertical and Horizontal Alignments
- 1220.04 Airport Clearance
- 1220.05 Railroad Crossings
- 1220.06 Procedures
- 1220.07 Documentation
- 1220.08 References

**Chapter 1230 Geometric Cross Section Basics**

- 1230.01 General
- 1230.02 Guidance for Specific Facility Types
- 1230.03 Common Elements
- 1230.04 Jurisdiction for Design and Maintenance
- 1230.05 References

**Chapter 1231 Geometric Cross Section – Highways**

- 1231.01 General
- 1231.02 Design Up
- 1231.03 Common Elements
- 1231.04 Vehicle Lanes
- 1231.05 Modally Integrated Cross Sections
- 1231.06 Road Diets and Retrofit Options
- 1231.07 References

**Chapter 1232 Geometric Cross Section – Freeways**

- 1232.01 General
- 1232.02 Lane Width

	1232.03	Shoulder Width
	1232.04	Other Elements
	1232.05	Design Flexibility
	1232.06	References
<b>Chapter 1238</b>	<b>Geometric Cross Section – Streetside and Parking</b>	
	1238.01	General
	1238.02	Parking
	1238.03	Streetside
	1238.04	Retrofit Options
	1238.05	References
<b>Chapter 1239</b>	<b>Geometric Cross Section – Shoulders, Side Slopes, Curbs, and Medians</b>	
	1239.01	Introduction
	1239.02	Shoulders
	1239.03	Side Slopes and Ditches
	1239.04	Roadway Sections in Rock Cuts
	1239.05	Curbs
	1239.06	Lateral Clearance to Curb and Barrier
	1239.07	Medians & Outer Separations
<b>Chapter 1240</b>	<b>Turning Roadways</b>	
	1240.01	General
	1240.02	Turning Roadway Widths
	1240.03	Documentation
	1240.04	References
<b>Chapter 1250</b>	<b>Cross slope and Superelevation</b>	
	1250.01	General
	1250.02	Roadway Cross Slope
	1250.03	Superelevation Rate Selection
	1250.04	Existing Curves
	1250.05	Turning Movements at Intersections
	1250.06	Runoff for Highway Curves
	1250.07	Runoff for Ramp Curves
	1250.08	Documentation
	1250.09	References
<b>Chapter 1260</b>	<b>Sight Distance</b>	
	1260.01	General
	1260.02	References
	1260.03	Stopping Sight Distance
	1260.04	Passing Sight Distance
	1260.05	Decision Sight Distance
	1260.06	Documentation
<b>Chapter 1270</b>	<b>Auxiliary Lanes</b>	
	1270.01	General
	1270.02	Climbing Lanes
	1270.03	Passing Lanes
	1270.04	Slow-Moving Vehicle Turnouts
	1270.05	Shoulder Driving for Slow Vehicles
	1270.06	Emergency Escape Ramps
	1270.07	Chain-Up and Chain-Off Areas
	1270.08	Documentation
	1270.09	References

## **Division 13 – Intersections and Interchanges**

### **Chapter 1300 Intersection Control Type**

- 1300.01 General
- 1300.02 Intersection Control Objectives
- 1300.03 Common Types of Intersection Control
- 1300.04 Modal Considerations
- 1300.05 Procedures
- 1300.06 Documentation
- 1300.07 References

### **Chapter 1310 Intersections**

- 1310.01 General
- 1310.02 Design Considerations
- 1310.03 Design Elements
- 1310.04 U-Turns
- 1310.05 Intersection Sight Distance
- 1310.06 Signing and Delineation
- 1310.07 Procedures
- 1310.08 Documentation
- 1310.09 References

### **Chapter 1320 Roundabouts**

- 1320.01 General
- 1320.02 Roundabout Types
- 1320.03 Capacity Analysis
- 1320.04 Geometric Design
- 1320.05 Pedestrians
- 1320.06 Bicycles
- 1320.07 Signing
- 1320.08 Pavement Marking
- 1320.09 Illumination
- 1320.10 Road Approach, Parking, and Transit Facilities
- 1320.11 Geometric Design Peer Review
- 1320.12 Documentation and Approvals
- 1320.13 References

### **Chapter 1330 Traffic Control Signals**

- 1330.01 General
- 1330.02 Procedures
- 1330.03 Intersection Design Considerations
- 1330.04 Conventional Traffic Signal Design
- 1330.05 Preliminary Signal Plan
- 1330.06 Operational Considerations for Design
- 1330.07 Documentation
- 1330.08 References

### **Chapter 1340 Driveways**

- 1340.01 General
- 1340.02 References
- 1340.03 Design Considerations
- 1340.04 Driveway Design Templates
- 1340.05 Sidewalks
- 1340.06 Driveway Sight Distance
- 1340.07 Stormwater and Drainage
- 1340.08 Mailboxes
- 1340.09 Documentation

**Chapter 1350 Railroad Grade Crossings**

- 1350.01 General
- 1350.02 References
- 1350.03 Plans
- 1350.04 Traffic Control Systems
- 1350.05 Nearby Roadway Intersections
- 1350.06 Pullout Lanes
- 1350.07 Crossing Surfaces
- 1350.08 Crossing Closure
- 1350.09 Traffic Control During Construction and Maintenance
- 1350.10 Railroad Grade Crossing Petitions and WUTC Orders
- 1350.11 Grade Crossing Improvement Projects
- 1350.12 Light Rail
- 1350.13 Documentation

**Chapter 1360 Interchanges**

- 1360.01 General
- 1360.02 Interchange Design
- 1360.03 Ramps
- 1360.04 Interchange Connections
- 1360.05 Ramp Terminal Intersections at Crossroads
- 1360.06 Interchanges on Two-Lane Highways
- 1360.07 Interchange Plans for Approval
- 1360.08 Documentation
- 1360.09 References

**Chapter 1370 Median Crossovers**

- 1370.01 General
- 1370.02 Analysis
- 1370.03 Design
- 1370.04 Plan Updates and Approvals
- 1370.05 Documentation

**Division 14 – HOV and Transit**

**Chapter 1410 High-Occupancy Vehicle Facilities**

- 1410.01 General
- 1410.02 Preliminary Design and Planning
- 1410.03 Operations
- 1410.04 Design Criteria
- 1410.05 Documentation
- 1410.06 References

**Chapter 1420 HOV Direct Access**

- 1420.01 General
- 1420.02 HOV Access Types and Locations
- 1420.03 Direct Access Geometrics
- 1420.04 Passenger Access
- 1420.05 Traffic Design Elements
- 1420.06 Documentation
- 1420.07 References

**Chapter 1430 Transit Facilities**

- 1430.01 General
- 1430.02 Bus Stops and Pullouts
- 1430.03 Passenger Amenities

1430.04	Park and Ride Lots
1430.05	Transfer/Transit Centers
1430.06	Roadway and Intersection Design
1430.07	Documentation
1430.08	References

## **Division 15 – Pedestrian and Bicycle Facilities**

### **Chapter 1510 Pedestrian Facilities**

1510.01	General
1510.02	References
1510.03	Definitions
1510.04	Policy
1510.05	ADA Requirements by Project Type
1510.06	Pedestrian Circulation Paths
1510.07	Pedestrian Access Routes (PARs)
1510.08	Sidewalks
1510.09	Curb Ramps
1510.10	Crosswalks
1510.11	Raised Medians/Traffic Islands
1510.12	Pedestrian Pushbuttons
1510.13	At-Grade Railroad Crossings
1510.14	Pedestrian Grade Separations (Structures)
1510.15	Other Pedestrian Facilities
1510.16	Illumination and Signing
1510.17	Work Zone Pedestrian Accommodation
1510.18	Documentation

### **Chapter 1515 Shared-Use Paths**

1515.01	General
1515.02	References
1515.03	Definitions
1515.04	Shared-Use Path Design – The Basics
1515.05	Intersections and Crossings Design
1515.06	Grade Separation Structures
1515.07	Signing, Pavement Markings, and Illumination
1515.08	Restricted Use Controls
1515.09	Documentation

### **Chapter 1520 Roadway Bicycle Facilities**

1520.01	General
1520.02	Roadway Bicycle Facility Types
1520.03	Bicycle Facility Selection
1520.04	Intersection Design Treatments
1520.05	Additional Bicycle Design Requirements and Considerations
1520.06	Documentation
1520.07	References

## **Division 16 – Roadside Safety Elements**

### **Chapter 1600 Roadside Safety**

1600.01	General
1600.02	Clear Zone
1600.03	Mitigation Guidance
1600.04	Medians
1600.05	Other Roadside Safety Features



- 1600.06 Documentation
- 1600.07 References

**Chapter 1610 Traffic Barriers**

- 1610.01 Introduction
- 1610.02 Barrier Impacts
- 1610.03 General Barrier Design Considerations
- 1610.04 Beam Guardrail
- 1610.05 High-Tension Cable Barrier
- 1610.06 Concrete Barrier
- 1610.07 Bridge Traffic Barriers
- 1610.08 Other Barriers
- 1610.09 References

**Chapter 1620 Impact Attenuator Systems**

- 1620.01 General
- 1620.02 Design Criteria
- 1620.03 Selection Considerations
- 1620.04 Transportable Attenuators (Truck-Mounted and Trailer-Mounted)
- 1620.05 Older Systems
- 1620.06 Inertial Barrier Systems (Sand Barrels)

**Division 17 – Roadside Facilities**

**Chapter 1710 Safety Rest Areas and Traveler Services**

- 1710.01 General
- 1710.02 References
- 1710.03 Definitions
- 1710.04 Safety Rest Area Project Team
- 1710.05 Location, Access, and Site Design
- 1710.06 Buildings
- 1710.07 Utilities
- 1710.08 Documentation

**Chapter 1720 Weigh Sites**

- 1720.01 General
- 1720.02 Definitions
- 1720.03 Planning, Development, and Responsibilities
- 1720.04 Permanent Facilities
- 1720.05 Portable Facilities
- 1720.06 Shoulder Sites
- 1720.07 Federal Participation
- 1720.08 Procedures
- 1720.09 Documentation

**Glossary**



110-1	Design Documentation Sequence for a Typical Design-Build Project
210-1	Types of Public Hearings
210-2	Public Hearing Formats
210-3	Prehearing Packet Checklist
210-4	Sequence for Corridor, Design, and Environmental Hearings
210-5	Sequence for Limited Access Hearing
210-6	Hearing Summary Approvals
300-1	Approval Authorities
300-2	Approvals
300-3	PS&E Process Approvals NHS (Including Interstate) and Non-NHS
300-4	Design to Construction Transition Project Turnover Checklist Example
301-1	General Input Form with Listed Performance Objectives
301-2	Design Option Worksheet Showing Example of Life Cycle Cost Assessment
301-3	Excerpts from Olympic Region Review Checklist
305-1	WSDOT Project Management Process
310-1	Seven-Phase Job Plan for VE Studies
310-2	VE Analysis Team Tools
310-3	Value Engineering Job Plan
400-1	Interagency Agreement
400-2	Report of Survey Mark Example
410-1	Monument Documentation Summary
410-2	DNR Permit Application
410-3	DNR Completion Report Form
410-4	Land Corner Record
510-1	Appraisal and Acquisition
520-1	Access Control Vocabulary
530-1a	Full Access Control Limits: Interchange
530-1b	Full Access Control Limits: Interchange
530-1c	Full Access Control Limits: Interchange With Roundabouts
530-1d	Full Access Control Limits: Ramp Terminal With Transition Taper
530-1e	Full Access Control Limits: Single Point Urban Interchange
530-1f	Full Access Control Limits: Diverging Diamond Interchange
530-2a	Partial Access Control Limits: At-Grade Intersections
530-2b	Partial Access Control Limits: Roundabout Intersections
530-3a	Modified Access Control Limits: Roundabout Intersections
530-3b	Modified Access Control Limits: Intersections

540-1	Managed Access Highway Class Description
540-2	Minimum Corner Clearance: Distance From Access Connection to Public Road or Street
550-1	Non-Access Feasibility Study Process
550-2	Access Revision Report Process
550-3	Access Revision Report: Stamped Cover Sheet Example
550-4	Access Revision Documentation and Review/Approval Levels
610-1	Materials Source Development
620-1	Estimating: Miscellaneous Tables
620-2	Estimating: Hot Mix Asphalt Pavement and Asphalt Distribution Tables
620-3	Estimating: Bituminous Surface Treatment
620-4	Estimating: Base and Surfacing Typical Section Formulae and Example
620-5a	Estimating: Base and Surfacing Quantities
620-5b	Estimating: Base and Surfacing Quantities
620-5c	Estimating: Base and Surfacing Quantities
620-5d	Estimating: Base and Surfacing Quantities
620-5e	Estimating: Base and Surfacing Quantities
620-5f	Estimating: Base and Surfacing Quantities
620-5g	Estimating: Base and Surfacing Quantities
620-5h	Estimating: Base and Surfacing Quantities
630-1	Selection Criteria for Geotextile Class
630-2	Maximum Sheet Flow Lengths for Silt Fences
630-3	Maximum Contributing Area for Ditch and Swale Applications
630-4	Design Process for Drainage and Erosion Control: Geotextiles and Nonstandard Applications
630-5	Design Process for Separation, Soil Stabilization, and Silt Fence
630-6	Examples of Various Geosynthetics
630-7	Geotextile Application Examples
630-8	Definition of Slope Length
630-9	Definition of Ditch or Swale Storage Length and Width
630-10	Silt Fences for Large Contributing Area
630-11	Silt Fence End Treatment
630-12	Gravel Check Dams for Silt Fences
700-1	Determination of the Roles and Responsibilities for Projects With Structures: Project Development Phase
710-1	Structure Site Data Checklist
720-1	Phased Development of Multilane Divided Highways
720-2	Highway Structure Over Railroad
720-3	Bridge Vertical Clearances
720-4	Embankment Slope at Bridge Ends
730-1	Summary of Mechanically Stabilized Earth (MSE) Gravity Wall/Slope Options Available

---

730-2	Summary of Prefabricated Modular Gravity Wall Options Available
730-3	Summary of Rigid Gravity and Semigravity Wall Options Available
730-4	Summary of Nongravity Wall Options Available
730-5	Summary of Anchored Wall Options Available
730-6	Other Wall/Slope Options Available
730-7	Typical Mechanically Stabilized Earth Gravity Walls
730-8	Typical Prefabricated Modular Gravity Walls
730-9	Typical Rigid Gravity, Semigravity Cantilever, Nongravity Cantilever, and Anchored Walls
730-10	Typical Rockery and Reinforced Slopes
730-11	MSE Wall Drainage Detail
730-12	Retaining Walls With Traffic Barriers
730-13a	Retaining Wall Design Process
730-13b	Retaining Wall Design Process: Proprietary
740-1	Standard Noise Wall Types
1010-1	General Lane Closure Work Zone Capacity
1010-2	Minimum Work Zone Clear Zone Distance
1010-3	Transportation Management Plan Components Checklist
1020-1	Reflective Sheeting Requirements for Overhead Signs
1020-2	Timber Posts
1020-3	Wide Flange Steel Posts
1020-4	Laminated Wood Box Posts
1030-1	Pavement Marking Material Guide – Consult Region Striping Policy
1030-2	Guidepost Placement
1040-1a	Freeway Lighting Applications
1040-1b	Freeway Lighting Applications
1040-1c	Freeway Lighting Applications
1040-2	Freeway Ramp Terminals
1040-3	Ramp With Meter
1040-4a	HOT (High-Occupancy Toll) Lane Enter/Exit Zone
1040-4b	HOT (High-Occupancy Toll) Lane Access Weave Lane
1040-5	Lane Reduction
1040-6a	Intersection With Left-Turn Channelization: Divided Highway
1040-6b	Intersections With Left-Turn Channelization
1040-6c	Intersections With Raised Left-Turn Channelization
1040-7	Intersections With Traffic Signals
1040-8	Intersection Without Channelization
1040-9	Roundabout
1040-10	Railroad Crossing With Gates or Signals
1040-11	Midblock Pedestrian Crossing

## **Exhibits**

---

1040-12	Transit Flyer Stop
1040-13	Major Parking Lot
1040-14	Minor Parking Lot
1040-15	Truck Weigh Site
1040-16	Safety Rest Area
1040-17	Chain-Up/Chain-Off Parking Area
1040-18	Bridge Inspection Lighting System
1040-19	Traffic Split Around an Obstruction
1040-20	Construction Work Zone and Detour
1040-21	Diverging Diamond Interchange
1040-22	Light Levels and Uniformity Ratios
1050-1	Systems Engineering Process (“V” Diagram)
1050-2	Intelligent Transportation Systems (ITS) Systems Engineering Analysis Worksheet
1050-3	FHWA Washington Division – ITS Project Contracting Guidance
1100-1	Basis of Design Flowchart
1102-1	Factors for Determining Initial Land Use Context
1103-1	WSDOT Design Controls
1103-2	Initial Modal Accommodation Level
1103-3	Example Characteristics Related to Modal Accomodation
1103-4	Target Speed Based on Land Use Context and Roadway Type
1103-5	Speed Transition Segment Example
1103-6	Geometric Traffic Calming Treatments and Considerations
1103-7	Roadside, Streetside, and Pavement-Oriented Traffic Calming Treatments
1105-1	Required Design Elements
1106-1	Dimensioning Guidance Variations
1106-2	Mode/Function/Performance Approach
1210-1	Maximum Angle Without Curve
1210-2a	Alignment Examples
1210-2b	Alignment Examples
1210-2c	Alignment Examples
1220-1	Grade Length
1220-2a	Coordination of Horizontal and Vertical Alignments
1220-2b	Coordination of Horizontal and Vertical Alignments
1220-2c	Coordination of Horizontal and Vertical Alignments
1220-3	Grading at Railroad Crossings
1230-1	Geometric Cross Section - Guide to Chapters
1230-2	State and City Jurisdictional Responsibilities
1231-1	Lane Widths for Highways
1231-2	Lane Width Considerations

---

1231-3	Motor Vehicle Oriented Cross Sections
1231-4	Cross Sections Featuring Bicycle Facilities
1231-5	Cross Sections Featuring Pedestrian Facilities
1231-6	Cross Sections Featuring Transit Facilities
1231-7	Complete Street Cross Sections
1232-1	Geometric Cross Section - Interstate (4 lanes shown, can vary)
1232-2	Geometric Cross Section – Non-Interstate (4 lanes shown, can vary)
1232-3	Median Section without Median Barrier
1238-1	Zones within the Streetside
1239-1	Shoulder Widths for Highways
1239-2	Shoulder Function & Modal Accommodation Width Considerations
1239-3	Shoulder Details
1239-3	Shoulder Details (continued)
1239-4	Drainage Ditch Details
1239-5a	Bridge End Slopes
1239-5b	Bridge End Slope Details
1239-6	Roadway Sections in Rock Cuts: Design A
1239-7	Roadway Sections in Rock Cuts: Design B
1239-8	Stepped Slope Design
1239-9	Minimum Lateral Clearance to Barrier and Curb
1239-10	Median Functions and Guidance: High and Intermediate Speeds
1239-11	Median Functions and Guidance: Low and Intermediate Speeds
1239-12a	Divided Highway Median Sections
1239-12b	Divided Highway Median Sections
1239-12c	Divided Highway Median Sections
1240-1a	Traveled Way Width for Two-Lane Two-Way Turning Roadways
1240-1b	Traveled Way Width for Two-Lane Two-Way Turning Roadways: Based on the Delta Angle
1240-2a	Traveled Way Width for Two-Lane One-Way Turning Roadways
1240-2b	Traveled Way Width for Two-Lane One-Way Turning Roadways: Based on the Delta Angle
1240-3a	Traveled Way Width for One-Lane Turning Roadways
1240-3b	Traveled Way Width for One-Lane Turning Roadways: Based on the Delta Angle, Radius on Outside Edge of Traveled Way
1240-3c	Traveled Way Width for One-Lane Turning Roadways: Based on the Delta Angle, Radius on Inside Edge of Traveled Way
1250-1	Minimum Radius for Normal Crown Section
1250-2	Minimum Radius for Existing Curves
1250-3	Side Friction Factor
1250-4a	Superelevation Rates (10% Max)

## **Exhibits**

---

1250-4b	Superelevation Rates (8% Max)
1250-4c	Superelevation Rates (6% Max)
1250-5	Superelevation Rates for Intersections and Low-Speed Urban Roadways
1250-6a	Superelevation Transitions for Highway Curves
1250-6b	Superelevation Transitions for Highway Curves
1250-6c	Superelevation Transitions for Highway Curves
1250-6d	Superelevation Transitions for Highway Curves
1250-6e	Superelevation Transitions for Highway Curves
1250-7a	Superelevation Transitions for Ramp Curves
1250-7b	Superelevation Transitions for Ramp Curves
1260-1	Design Stopping Sight Distance
1260-2	Design Stopping Sight Distance on Grades
1260-3	Stopping Sight Distance on Grades
1260-4	Stopping Sight Distance: Crest Vertical Curves
1260-5	Sight Distance: Crest Vertical Curve
1260-6	Stopping Sight Distance for Sag Vertical Curves
1260-7	Sight Distance: Sag Vertical Curve
1260-8	Horizontal Stopping Sight Distance
1260-9	Sight Distance: Horizontal Curves
1260-10	Sight Distance: Overlapping Horizontal and Crest Vertical Curves
1260-11	Existing Stopping Sight Distance
1260-12	Passing Sight Distance
1260-13	Passing Sight Distance: Crest Vertical Curve Calculations
1260-14	Passing Sight Distance: Crest Vertical Curves
1260-15	Decision Sight Distance
1270-1	Climbing Lane Example
1270-2a	Speed Reduction Warrant: Performance for Trucks
1270-2b	Speed Reduction Warrant Example
1270-3	Auxiliary Climbing Lane
1270-4	Passing Lane Example
1270-5	Length of Passing Lanes
1270-6	Passing Lane Configurations
1270-7	Buffer Between Opposing Passing Lanes
1270-8	Auxiliary Passing Lane
1270-9	Emergency Escape Ramp Example
1270-10	Emergency Escape Ramp Length
1270-11	Rolling Resistance (R)
1270-12	Typical Emergency Escape Ramp
1270-13	Chain Up/Chain Off Area



---

1300-1	Intersection Design Considerations
1300-2	Median U-Turn Intersection Example
1300-3	Restricted Crossing U-Turn Intersection Example with Stop-control
1300-4	Displaced Left Turn Intersection Example
1310-1	Lane Alignment Taper Rate
1310-2	Ramp Terminal Intersection Details
1310-3	Median at Two-Way Ramp Terminal
1310-4	Intersection Balance Example
1310-5	Diamond Interchange With Advance Storage
1310-6	Initial Ranges for Right-Turn Corner (Simple Curve-Taper)
1310-7a	Left-Turn Storage Guidelines: Two-Lane, Unsignalized
1310-7b	Left-Turn Storage Guidelines: Four-Lane, Unsignalized
1310-8a	Left-Turn Storage Length: Two-Lane, Unsignalized (40 mph)
1310-8b	Left-Turn Storage Length: Two-Lane, Unsignalized (50 mph)
1310-8c	Left-Turn Storage Length: Two-Lane, Unsignalized (60 mph)
1310-9	Left-Turn Storage With Trucks (ft)
1310-10a	Median Channelization: Widening
1310-10b	Median Channelization: Median Width 11 ft or More
1310-10c	Median Channelization: Median Width 23 ft to 26 ft
1310-10d	Median Channelization: Median Width of More Than 26 ft
1310-10e	Median Channelization: Minimum Protected Storage
1310-10f	Median Channelization: Two-Way Left-Turn Lane
1310-11	Right-Turn Lane Guidelines
1310-12	Right-Turn Pocket and Right-Turn Taper
1310-13	Right-Turn Lane
1310-14	Acceleration Lane
1310-15a	Traffic Island Designs
1310-15b	Traffic Island Designs: Compound Curve
1310-15c	Traffic Island Designs
1310-16	U-Turn Spacing
1310-17	U-Turn Roadway
1310-18	U-Turn Median Openings
1310-19a	Sight Distance at Intersections
1310-19b	Sight Distance at Intersections
1320-1	Suggested Initial Design Ranges
1320-2	Radii-Speed Relationship on Approach Legs and R Value Relationships
1320-3	Intersection Sight Distance
1330-1	Responsibility for Facilities
1330-2	Example Continuous Green "T" (CGT) Intersection Layout

1330-3	Left-Turn Lane Configuration Examples
1330-4	Recommended Features for Intersections Near Rail Crossings
1330-5	Standard Intersection Movements, Head Numbers, and Phase Operation
1330-6	Detector Numbering Examples
1330-7a	Signal Display Placements – Key to Diagrams
1330-7b	Signal Displays for Single Lane Approach
1330-7c	Signal Display Mounting Locations for Multi-Lane Approaches
1330-7d	Signal Displays for Dedicated Left Turn Lanes
1330-7e	Signal Displays for Shared Through-Left Lanes – Multiple Through Lanes
1330-7f	Signal Displays for Shared Through-Right Lanes
1330-7g	Signal Displays for Dedicated Right Turn Lanes
1330-7h	Signal Displays for Multiple Turn Lanes
1330-8	Example Signal Display Placement for Skew Intersection
1330-9	Signal Display Maximum Heights
1330-10	Pedestrian Display Placement Requirements
1330-11	PPB Placement Requirements
1330-12a	PPB Placement on Vertical Shaft Poles
1330-12b	PPB Placement on Large Signal Standards
1330-13	Signal Display Surface Areas
1330-14	Timber Strain Pole Classes
1330-15	Fixed Vehicle Detection Placement
1330-16	Decision Zone Detection Placement
1330-17	Video Detector Placement
1330-18	Signal Display Layout for Rail Crossings
1330-19	Conduit and Conductor Sizes
1330-20	Phase Diagrams: Four-Way Intersections
1330-21	Phase Diagrams: Three-Way Intersections
1330-22	Phasing at Railroad Crossings
1340-1	Driveway Design Template SU-30 and Smaller
1340-2	Driveway Design Template SU-30 and Larger
1340-3	Driveway Sight Distance
1350-1	Sight Distance at Railroad Crossing
1350-2	Typical Pullout Lane at Railroad Crossing
1360-1	Basic Interchange Patterns
1360-2	Interchange Spacing
1360-3	Minimum Ramp Connection Spacing
1360-4	Ramp Design Speed
1360-5	Maximum Ramp Grade
1360-6	Ramp Widths

---

1360-7a	Lane Balance
1360-7b	Lane Balance
1360-8	Main Line Lane Reduction Alternatives
1360-9	Acceleration Lane Length
1360-10	Deceleration Lane Length
1360-11a	Gore Area Characteristics
1360-11b	Gore Area Characteristics
1360-12	Length of Weaving Sections
1360-13a	On-Connection: Single-Lane, Tapered
1360-13b	On-Connection: Single-Lane, Parallel
1360-13c	On-Connection: Two-Lane, Parallel
1360-13d	On-Connection: Two-Lane, Tapered
1360-14a	Off-Connection: Single-Lane, Tapered
1360-14b	Off-Connection: Single-Lane, Parallel
1360-14c	Off-Connection: Single-Lane, One-Lane Reduction
1360-14d	Off-Connection: Two-Lane, Tapered
1360-14e	Off-Connection: Two-Lane, Parallel
1360-15a	Collector-Distributor: Outer Separations
1360-15b	Collector Distributor: Off-Connections
1360-15c	Collector Distributor: On-Connections
1360-16	Loop Ramp Connections
1360-17	Temporary Ramps
1360-18	Interchange Plan
1410-1	Minimum Traveled Way Widths for Articulated Buses
1410-2	Typical HOV Lane Sections
1410-3	Roadway Widths for Two-Lane Ramps With an HOV Lane
1410-4a	Single-Lane Ramp Meter With HOV Bypass
1410-4b	Two-Lane Ramp Meter With HOV Bypass
1410-5a	Enforcement Area: One Direction Only
1410-5b	Enforcement Area: Median
1430-1	Bus Zone Dimensions
1430-2	Pullout for Bus Stop along a Road
1430-3	Bus Stop Pullouts: Arterial Streets
1430-4	Bus Zone and Pullout After Right Turn
1430-5	Bus Stop Accessibility Features
1430-6	Bus Berth Design
1430-7	Design Alternative for a Combination of Bus Berths at a Platform
1510-1	Pedestrian Circulation Paths
1510-2	Relationship Between Pedestrian Circulation Paths and Pedestrian Access Routes

## **Exhibits**

---

1510-3	Obstructed Pedestrian Access Route
1510-4	Beveling Options
1510-5	Surface Discontinuities (Noncompliant)
1510-6	Sidewalks With Buffers
1510-7	Typical Sidewalk Designs
1510-8	Typical Driveways
1510-9	Perpendicular Curb Ramp
1510-10	Perpendicular Curb Ramp Common Elements
1510-11	Parallel Curb Ramp
1510-12	Parallel Curb Ramp Common Elements
1510-13	Combination Curb Ramp
1510-14	Typical Curb Ramp Drainage
1510-15	Unmarked Crosswalks
1510-16	Marked Pedestrian Crossing
1510-17	Vacant
1510-18	Midblock Pedestrian Crossing
1510-19	Obstructed Line of Sight at Intersection
1510-20	Improved Line of Sight at Intersection
1510-21	Curb Extension Examples
1510-22	Raised Islands With Curb Ramps and Pedestrian Cut-Throughs
1510-23	Clear Space for Pedestrian Pushbutton
1510-24a	Perpendicular Ramp Concurrent Clear Space Examples
1510-24b	Parallel Ramp Concurrent Clear Space Examples
1510-25	Reach Range for Pedestrian Pushbutton
1510-26	Pedestrian Railroad Crossings
1510-27	Pedestrian Railroad Warning Device
1510-28	Pedestrian Bridges
1510-29	Pedestrian Tunnel
1510-30	Access Ramp With Accessible Handrails
1510-31	Work Zones and Pedestrian Facilities
1515-1	Shared-Use Path
1515-2	Bicycle Design Speeds
1515-3	Two-Way Shared-Use Path: Independent Alignment
1515-4a	Two-Way Shared-Use Path: Adjacent to Roadway ( $\leq$ 35 mph)
1515-4b	Two-Way Shared-Use Path: Adjacent to Roadway ( $>$ 35 mph)
1515-4c	Two-Way Shared-Use Path: Attached to Roadway ( $>$ 35 mph)
1515-5	Shared-Use Path Side Slopes and Railing
1515-6	Shared-Use Path Landing Profile
1515-7	Shared-Use Path Landing and Rest Area

---

1515-8	Typical Redesign of a Diagonal Midblock Crossing
1515-9	Adjacent Shared-Use Path Intersection
1515-10	Roadway Crossing Refuge Area
1515-11	Shared-Use Path Bridge and Approach Walls
1515-12	Bridge and Pedestrian Rail
1515-13	Shared-Use Path in Limited Access Corridor
1515-14a	Stopping Sight Distance for Downgrades
1515-14b	Stopping Sight Distance for Upgrades
1515-15	Minimum Lengths for Crest Vertical Curves
1515-16	Lateral Clearance for Horizontal Curves
1520-1	Raised and Curb-Separated Bike Facility
1520-2	Separated Buffered Bike Lane
1520-3	Buffered Bike Lane
1520-4	Bike Lane
1520-5	Shared Lane Markings
1520-6a	Bicycle Facility Selection Chart – Interested, but Concerned Cyclists
1520-6b	Bicycle Facility Selection Chart – Confident Cyclists
1520-7	Approach Through Lanes
1520-8	Bike Box and Intersection Crossing Markings
1520-9	Two-Stage Left-Turn Queue Box
1520-10	Median Refuge Island for Cyclists
1520-11	Length of Solid Green Pavement Marking Preceding Conflict Area
1520-12	At-Grade Railroad Crossings
1520-13	Barrier Adjacent to Bicycle Facilities
1520-14a	Bike Facility Crossing On and Off Ramps
1520-14b	Bicycle Facility Crossing Single Lane On Ramp
1520-14c	Bicycle Facility Crossing Option for Dual Lane On-Ramp Configuration
1520-14d	Bicycle Facility Crossing Option for Dual Off-Ramp
1600-1	City and State Responsibilities and Jurisdictions
1600-2	Design Clear Zone Distance Table
1600-3	Design Clear Zone Inventory Form Link to Website for the form
1600-4	Recovery Area
1600-5	Design Clear Zone for Ditch Sections
1600-6	Guidelines for Embankment Barrier
1600-7	Mailbox Location and Turnout Design
1600-8	Glare Screens
1610-1	Concrete Barrier Placement Guidance: Assessing Impacts to Wildlife
1610-2	Traffic Barrier Locations on Slopes
1610-3	Longitudinal Barrier Deflection

## **Exhibits**

---

1610-4	Longitudinal Barrier Flare Rates
1610-5	Barrier Length of Need on Tangent Sections
1610-6	Barrier Length of Need
1610-7	Barrier Length of Need on Curves
1610-8	W-Beam Guardrail Trailing End Placement for Divided Highways
1610-9	Beam Guardrail Installation on 6:1 to 10:1 Slopes
1610-10	Beam Guardrail Post Installation
1610-11	Vacant
1610-12	Guardrail Connections
1610-13	Transitions and Connections
1610-14a	Median Cable Barrier Placement
1610-14b	Roadside Cable Barrier Placement
1610-15	Cable Barrier Placement for Divided Highways
1610-16	Concrete Barrier Shapes
1610-17	Type 7 Bridge Rail Upgrade Criteria
1610-18	Thrie Beam Rail Retrofit Criteria
1620-1	Impact Attenuator Distance Beyond Length of Need
1710-1	WSDOT Safety Rest Area
1710-2	WSDOT's SRA Project and Programming Roles
1710-3	Additional Safety Rest Area Resources
1710-4	Roadside Facilities Level of Development
1710-5	Typical Truck Storage
1710-6	WSDOT Safety Rest Area Building – Adaptive Reuse Historic Preservation
1720-1	Truck Weigh Site: Multilane Highways
1720-2	Truck Weigh Site: Two-Lane Highways
1720-3	Vehicle Inspection Installation
1720-4	Minor Portable Scale Site
1720-5	Major Portable Scale Site
1720-6	Small Shoulder Site
1720-7	Large Shoulder Site
1720-8	MOU Related to Vehicle Weighing and Equipment: Inspection Facilities on State Highways

- 100.01 Purpose
- 100.02 Presentation and Revisions
- 100.03 Practical Solutions
- 100.04 Manual Applications
- 100.05 Manual Use
- 100.06 Manual Organization

## 100.01 Purpose

WSDOT has developed the *Design Manual* to reflect policy, outline a uniformity of methods and procedures, and communicate vital information to its employees and others who develop projects on state highways. When properly used, the manual will facilitate the development of a highway system consistent with the needs of the multimodal traveling public.

WSDOT designers are required to comply with the *Design Manual*. The Federal Highway Administration (FHWA) has agreed to approve designs that follow guidance in the *Design Manual*; therefore, adherence to the guidance presented is not optional for state highway projects.

The information, guidance, and references contained herein are not intended as a substitute for sound engineering judgment. The *Design Manual* is not a comprehensive textbook on highway engineering, nor does it attempt to cover all the possible scenarios Washington's highways present. It is recognized that some situations encountered are beyond the scope of this presentation.

If you have design questions not answered by the *Design Manual*, contact the Headquarters (HQ) Design Office.

## 100.02 Presentation and Revisions

The *Design Manual* is available on the Internet. It can be accessed through the:

- WSDOT Home Page:  
[www.wsdot.wa.gov/](http://www.wsdot.wa.gov/)
- Design Policy Web Page:  
[www.wsdot.wa.gov/design/policy/](http://www.wsdot.wa.gov/design/policy/)
- Active *Design Manual* Revisions Web Page:  
[www.wsdot.wa.gov/design/manual/activerevisions.htm](http://www.wsdot.wa.gov/design/manual/activerevisions.htm)
- Publications Services Web Page:  
[www.wsdot.wa.gov/publications/manuals/index.htm](http://www.wsdot.wa.gov/publications/manuals/index.htm)

The online version of the manual enables you to conduct a word search of the entire manual. Opening an individual chapter is faster, but a word search is limited to that chapter.

The *Design Manual* is continually revised to reflect changing processes, procedures, regulations, policies, and organizations. Feedback from users is encouraged to improve the manual for everyone. Comments may be submitted by any method that is convenient for you. There is a comment form in the front of the manual, or comments may be made via the contact names on the Design Policy Internet page (see link above). Note that the Design Policy Internet page includes a link to an errata page, which provides a list of known technical errors in the manual. Manual users are encouraged to view this page on a regular basis.

A contents section lists all chapters and the major headings of the sections/pages. The exhibits section lists all the exhibits in the manual.

Most chapters include a list of references, including laws, administrative codes, manuals, and other publications, which are the basis for the information in the chapter. The definitions for terms used in the *Design Manual* are found in the [Glossary](#).

### 100.03 Practical Solutions

WSDOT deploys Practical Solutions to enable more flexible and sustainable transportation investment decisions. It encourages this by: (1) increasing the focus on addressing identified performance gaps (needs) throughout all phases of development, and (2) engaging local stakeholders at the earliest stages of scope definition to ensure their input is included at the right stage of the solution development process. Practical Solutions includes one or a combination of strategies, including, but not limited to, operational improvements, off-system solutions, transportation demand management, and incremental strategic capital solutions. (See [Chapter 1100](#) for more information.)

### 100.04 Manual Applications

*Design Manual* guidance is provided to encourage the statewide uniform application of design details under normal conditions. It also guides designers through the project development process used by WSDOT. The *Design Manual* is used by the department to:

- Interpret current design principles, including American Association of State Highway and Transportation Officials (AASHTO) and other appropriate policy sources, findings, and federal and state laws.
- Develop projects that address modal and community performance needs.
- Balance the competing performance needs of highway construction projects.
- Design for low-cost solutions.

The *Design Manual* is designed to allow for flexibility in design for specific and unusual situations. For unusual circumstances, the manual provides mechanisms for documenting the reasons for the choices made.

The *Design Manual* is developed for use on Interstate and state highways and may not be suitable for projects on county roads or city streets.

### 100.05 Manual Use

The WSDOT *Design Manual* is intended to be used for design of department-owned facilities, especially the transportation facilities associated with state highways as designated by [RCW 47.17](#).



For state highway routes, projects are designed using the *Design Manual* practical design approach (see [Chapter 1100](#) and Division 11). If WSDOT guidance is not used on a project, appropriate documentation and approvals are required (see [Chapters 300](#) and [1100](#)).

When WSDOT designs facilities that will be turned over to local jurisdictions, those facilities are to be designed using appropriate local geometric design criteria.

When local jurisdictions design any element of state highway facilities, the *Design Manual* must be used. Local jurisdictions are free to adopt this manual for their local criteria or to develop their own specialized guidance for facilities not on state highway routes.

## 100.06 Manual Organization

The *Design Manual* is divided into a series of divisions that address a portion of the project development and design processes. The divisions are composed of chapters that address the general topic in detail and are, in some cases, specific to a particular discipline.

**Division 1 – General Information:** Presents an overview of the Design Manual, its contents and application, as well as a chapter on Design-Build projects.

- **Chapter 100 – Manual Description:** Chapter content/resources within the *Design Manual*.
- **Chapter 110 – Design-Build Projects:** How the *Design Manual* applies to design-build projects: includes terminology and reference to design-build contract documents.

**Division 2 – Hearings, Environmental, and Permits:** Provides the designer with information about the public involvement and hearings process, the environmental documentation process, and the permit process.

- **Chapter 210 – Public Involvement and Hearings:** Developing a project-specific public involvement plan; the ingredients of an effective public involvement plan; and methods for public involvement.
- **Chapter 225 – Environmental Coordination:** Provides a summary of the relevant provisions in the *Environmental Manual*. Gives designers a brief overview and direction to environmental resources.

**Division 3 – Project Documentation:** Provides designers with information on project management, value engineering, traffic and safety analysis, design documentation, and approvals.

- **Chapter 300 – Design Documentation, Approval, and Process Review:** Building the Project File (PF) and the Design Documentation Package (DDP) and recording the recommendations and decisions that lead to a project by preserving the documents from the planning, scoping, programming, and design phases (includes permits, approvals, contracts, utility relocation, right of way, advertisement and award, and construction). Links to websites to download documentation templates.

- **Chapter 301 – Design and Maintenance Coordination – Best Practices:** Means and methods for coordinating design with maintenance concerns and needs.
- **Chapter 305 – Project Management:** Brief description and links to WSDOT project management resources.
- **Chapter 310 – Value Engineering:** A systematic, multidisciplinary process study early in the project design stage to provide recommendations to improve scope, functional design, constructability, environmental impacts, or project cost—required by federal law for high-cost, complex projects.
- **Chapter 320 – Traffic Analysis:** Procedural guidance and general requirements for conducting traffic analyses.
- **Chapter 321 – Sustainable Safety Analysis:** Informational and procedural guidance for conducting safety analyses, within the current extent of the applications.

**Division 4 – Surveying:** Includes criteria for surveying, mapping, and monumentation requirements.

- **Chapter 400 – Surveying and Mapping:** The procedures within WSDOT for project surveying.
- **Chapter 410 – Monumentation:** The requirements and procedures for Monumentation.

**Division 5 – Right of Way and Access Control:** Provides guidance on right of way considerations; access revision report; limited/managed access; and fencing.

- **Chapter 510 – Right of Way Considerations:** The right of way and easement acquisition process.
- **Chapter 520 – Access Control:** WSDOT Access Control program information.
- **Chapter 530 – Limited Access Control:** Clarification on full, partial, and modified limited access control.
- **Chapter 540 – Managed Access Control:** The classes of managed access highways and the access connection permitting process.
- **Chapter 550 – Freeway Access Revision:** The process for interchange access revisions on freeways and the steps for producing an access revision report.
- **Chapter 560 – Fencing:** The purpose of fencing, types of fencing, and fencing design criteria.

**Division 6 – Soils and Paving:** Presents guidance for investigating soils, rock, and surfacing materials; estimating tables; and guidance and criteria for the use of geosynthetics.

- **Chapter 610 – Investigation of Soils, Rock, and Surfacing Materials:** The requirements for qualifying a materials source, geotechnical investigations, and the documentation to be included in the Project File.
- **Chapter 620 – Design of Pavement Structures:** Estimating tables for the design of pavement structures.
- **Chapter 630 – Geosynthetics:** The types/applications of geosynthetic drainage, earthwork, erosion control, and soil reinforcement materials.

**Division 7 – Structures:** Provides guidance for the design of structures for highway projects, including site data for structures, bridges, retaining walls, and noise walls.

- **Chapter 700 – Project Development Roles and Responsibilities for Projects With Structures:** WSDOT’s project development process: roles and responsibilities for projects with structures during the project development phase of a project.
- **Chapter 710 – Site Data for Structures:** Information required by the HQ Bridge and Structures Office to provide structural design services.
- **Chapter 720 – Bridges:** Basic design considerations for developing preliminary bridge plans and guidelines on basic bridge geometric features.
- **Chapter 730 – Retaining Walls and Steep Reinforced Slopes:** Design principles, requirements, and guidelines for retaining walls and steep reinforced slopes.
- **Chapter 740 – Noise Barriers:** Factors considered when designing a noise barrier.

**Division 8 – Hydraulics:** Addresses the issue of hydraulics and serves as a guide to highway designers to identify and consider hydraulic-related factors that may impact the design.

- **Chapter 800 – Hydraulic Design:** Hydraulic considerations for highway projects involving flood plains, stream crossings, channel changes, and groundwater.

**Division 9 – Roadside Development:** Provides guidance on the portion of state highways between the traveled way and the right of way boundary.

- **Chapter 900 – Roadside Development:** Managing the roadside environment, including the area between the traveled way and the right of way boundary, unpaved median strips, and auxiliary facilities such as rest areas, wetlands, and stormwater treatment facilities.
- **Chapter 950 – Public Art:** Policies and procedures for including public art in state transportation corridors.

**Division 10 – Traffic Safety Elements:** Introduces the designer to traffic safety elements such as work zone traffic control, signing, delineation, illumination, traffic control signals, and Intelligent Transportation Systems (ITS).

- **Chapter 1010 – Work Zone Safety and Mobility:** Planning, design, and preparation of highway project plans that address work zone safety and mobility requirements.
- **Chapter 1020 – Signing:** The use of signing to regulate, warn, and guide motorists.
- **Chapter 1030 – Delineation:** The use of pavement markings to designate safe traffic movement.
- **Chapter 1040 – Illumination:** Illumination design on state highway construction projects.
- **Chapter 1050 – Intelligent Transportation Systems (ITS):** Applying computer and communication technology to optimize the safety and efficiency of the highway system.

**Division 11 – Practical Design:** Provides practical design guidance for WSDOT projects.

- **Chapter 1100 – Practical Design:** Includes an overview and description of the WSDOT Practical Solutions initiative, the practical design process, and the relevant chapter information necessary to complete each process step.

- **Chapter 1101 – Need Identification:** Includes guidance on accurate and concise identification of project needs for practical design.
- **Chapter 1102 – Context Identification:** Guidance provided to help determine the highway's land use context and transportation context.
- **Chapter 1103 – Design Control Selection:** Provides guidance on design controls used in WSDOT projects.
- **Chapter 1104 – Alternatives Analysis:** Discusses how information determined from planning phases and *Design Manual* chapters is utilized in alternative solution formation, and how to evaluate the alternative solutions developed.
- **Chapter 1105 – Design Element Selection:** Provides guidance on selecting design elements for projects.
- **Chapter 1106 – Design Element Dimensions:** Discusses the practical design approach to selecting design element dimensions.
- **Chapter 1120 – Preservation Projects:** Provides scoping links and elements and features to be evaluated in preservation projects.

**Division 12 – Geometrics:** Covers geometric plan elements; horizontal alignment; lane configurations and pavement transitions; geometric profile elements; vertical alignment; geometric cross sections; and sight distance.

- **Chapter 1210 – Geometric Plan Elements:** The design of horizontal alignment, lane configuration, and pavement transitions.
- **Chapter 1220 – Geometric Profile Elements:** The design of vertical alignment.
- **Chapter 1230 – Geometric Cross Section – Basics:** Roadway cross section introductory chapter; guide to other cross section chapters; provides jurisdictional guidance.
- **Chapter 1231 – Geometric Cross Section – Highways:** Geometric cross section guidance for all highways except freeways.
- **Chapter 1232 – Geometric Cross Section – Freeways:** cross section guidance for freeways and Interstates.
- **Chapter 1238 – Geometric Cross Section – Streetside and Parking:** provides information on parking and streetside elements.
- **Chapter 1239 – Geometric Cross Section – Shoulders, Side Slopes, Curbs, and Medians:** Provides information on geometric cross section components common to many facility types. Cross section elements include: shoulders, medians and outer separations, side slopes, and curbing
- **Chapter 1240 – Turning Roadways:** Widening curves to make the operating conditions comparable to those on tangent sections.
- **Chapter 1250 – Cross Slope and Superelevation:** Cross slope design information is provided as well as superelevating curves and ramps so design speeds can be maintained.
- **Chapter 1260 – Sight Distance:** Stopping, passing, and decision sight distance design elements.

- **Chapter 1270 – Auxiliary Lanes:** Auxiliary facilities such as climbing lanes, passing lanes, slow-vehicle turnouts, shoulder driving for slow vehicles, emergency escape ramps, and chain-up areas.

**Division 13 – Intersections and Interchanges:** Addresses the design considerations of at-grade intersections, roundabouts, road approaches, railroad grade crossings, and traffic interchanges.

- **Chapter 1300 – Intersection Control Type:** Guidance on preliminary intersection evaluation and selection of control type.
- **Chapter 1310 – Intersections:** Designing intersections at grade, including at-grade ramp terminals.
- **Chapter 1320 – Roundabouts:** Guidance on the design of roundabouts.
- **Chapter 1330 – Traffic Control Signals:** The use of power-operated traffic control devices that warn or direct traffic.
- **Chapter 1340 – Driveways:** The application and design of road approaches on state highways.
- **Chapter 1350 – Railroad Grade Crossings:** The requirements for highways that cross railroads.
- **Chapter 1360 – Traffic Interchanges:** The design of interchanges on interstate highways, freeways, and other multilane divided routes.
- **Chapter 1370 – Median Crossovers:** Guidance on locating and designing median crossovers for use by maintenance, traffic service, emergency, and law enforcement vehicles.

**Division 14 – HOV and Transit:** Provides design guidance on HOV lanes and transit facilities.

- **Chapter 1410 – High-Occupancy Vehicle Facilities:** Evaluating and designing high-occupancy vehicle (HOV) facilities.
- **Chapter 1420 – HOV Direct Access:** Design guidance on left-side direct access to HOV lanes and transit facilities.
- **Chapter 1430 – Transit Facilities:** Operational guidance and information for designing transit facilities such as park & ride lots, transfer/ transit centers, and bus stops and pullouts.

**Division 15 – Pedestrian and Bicycle Facilities:** Provides guidance on pedestrian and bicycle facility design.

- **Chapter 1510 – Pedestrian Facilities:** Designing facilities that encourage efficient pedestrian access that meets ADA.
- **Chapter 1515 – Shared-Use Paths:** Guidance that emphasizes pedestrians are users of shared-use paths and accessibility requirements apply in their design.
- **Chapter 1520 – Roadway Bicycle Facilities:** Selecting and designing useful and cost-effective bicycle facilities.

**Division 16 – Roadside Safety Elements:** Addresses design considerations for the area outside the roadway, and includes clear zone, roadside, safety mitigation, traffic barriers, and impact attenuator systems.

- **Chapter 1600 – Roadside Safety:** Clear zone and roadside design, mitigation guidance, and roadside safety features, including Rumble Strips.
- **Chapter 1610 – Traffic Barriers:** Design of traffic barriers.
- **Chapter 1620 – Impact Attenuator Systems:** Permanent and work zone impact attenuator systems.

**Division 17 – Roadside Facilities:** Provides design guidance for the area outside the roadway, including rest areas and truck weigh sites.

- **Chapter 1710 – Safety Rest Areas and Traveler Services:** Typical layouts for safety rest areas.
- **Chapter 1720 – Weigh Sites:** Guidance on designing permanent, portable, and shoulder-sited weigh sites.

- 300.01 General
- 300.02 WSDOT Project Delivery
- 300.03 Design Documentation and Records Retention Policy
- 300.04 Project Design Approvals
- 300.05 FHWA Oversight and Approvals
- 300.06 Project Documents and Approvals
- 300.07 Process Review
- 300.08 References

### 300.01 General

This chapter provides the WSDOT design procedures, documentation and approvals necessary to deliver successful projects on the transportation network in Washington, including projects involving the Federal Highways Administration.

This chapter presents critical information for design teams, including:

- WSDOT’s Project Development process.
- Design documentation tools, procedures, and records retention policy.
- Major Project approvals including Design Approval, Project Development Approval, Basis of Design, Design Analysis, and other specific project documents for design-bid-build and for design-build delivery methods.
- FHWA oversight and approvals on Projects of Division Interest (PoDI).
- WSDOT and FHWA approvals for non-PoDI projects including Interstate new and reconstruction and other specific documents as shown in the approvals exhibits.
- Information about conducting project process reviews.
- Additional references and resources.

For local agency and developer projects on state highways, design documentation is also needed. It is retained by the region office responsible for the project oversight, in accordance with the WSDOT records retention policy. All participants in the design process are to provide the appropriate documentation for their decisions. For more information about these types of projects, see the [Local Agency Guidelines](#) and [Development Services Manual](#) available at the Publications Services Index website:

[www.wsdot.wa.gov/Publications/Manuals/index.htm](http://www.wsdot.wa.gov/Publications/Manuals/index.htm)

**For operational changes** identified by the Traffic Office Low Cost Enhancement or Field Assessment Program that are included in a project, design documentation is also needed. It is retained by the region office responsible for the project oversight, in accordance with the WSDOT records retention policy. This documentation will be developed by the region Traffic Office in accordance with HQ Traffic Office direction and included in the design documentation for the project.

For emergency projects, also refer to the [Emergency Relief Procedures Manual](#). It provides the legal and procedural guidelines for WSDOT employees to prepare all necessary documentation to respond to, and recover from, emergencies and disasters that affect the operations of the department.

## 300.02 WSDOT Project Delivery

A project, and its delivery method, is developed in accordance with all applicable procedures, Executive Orders, Directives, Instructional Letters, Supplements, and manuals; the Washington State Highway System Plan; approved corridor sketches and planning studies; the FHWA/WSDOT Stewardship and Oversight Agreement; scoping phase documentation, and the Basis of Design.

The delivery method is determined using the WSDOT Project Delivery Method Selection Guidance Memorandum found here:

[www.wsdot.wa.gov/Projects/delivery/designbuild/PDMSG.htm](http://www.wsdot.wa.gov/Projects/delivery/designbuild/PDMSG.htm)

See the implementation memorandum for procedural policy and guidance in the selection of probable and final project delivery method, timing for these determinations, and approval and endorsement levels.

The region develops and maintains documentation for each project using this chapter and the Project File / Design Documentation Package checklists (see [300.03\(3\)](#))

Refer to the [Plans Preparation Manual](#) for PS&E documentation. Exhibit 300-4 is an example checklist of recommended items to be turned over to the construction office at the time of project transition. An expanded version is available here:

[www.wsdot.wa.gov/design/projectdev/](http://www.wsdot.wa.gov/design/projectdev/)

### 300.02(1) Environmental Requirements

All projects involving a federal action require National Environmental Policy Act (NEPA) documentation. WSDOT uses the Environmental Review Summary (ERS) portion of Project Summary for FHWA concurrence on the environmental class of action (EIS/EA/CE). The environmental approval levels are shown in [Exhibit 300-2](#).

Upon receipt of the ERS approval for projects requiring an EA or EIS under NEPA, the region proceeds with environmental documentation, including public involvement, appropriate for the magnitude and type of the project (see [Chapter 210](#) and [WSDOT Community Engagement Plan](#)).

### 300.02(2) Real Estate Acquisition

Design Approval and approval of right of way plans are required prior to acquiring property. A temporary construction easement may be acquired prior to Design Approval for State funded projects and with completion of NEPA for Federally funded projects. For early acquisition of right of way, consult the Real Estate Services Office, the April 2, 2013 memorandum on early acquisition policy, and [Right of Way Manual](#) Chapter 6-3.



## 300.03 Design Documentation and Records Retention Policy

### 300.03(1) Purpose

Design documentation records the evaluations and decisions by the various disciplines that result in design recommendations. Design assumptions and decisions made prior to and during the scoping phase are included. Changes that occur throughout project development are documented. Required justifications and approvals are also included.

### 300.03(2) Certification of Documents by Licensed Professionals

All original technical documents must bear the certification of the responsible licensee as listed in [Executive Order E 1010](#).

### 300.03(3) Project File and Design Documentation Package

The Project File and Design Documentation Package include documentation of project work, including planning; scoping; community engagement; environmental action; the Basis of Design; right of way acquisition; Plans, Specifications, and Estimates (PS&E) development; project advertisement; and construction.

The **Project File (PF)** contains the documentation for planning, scoping, programming, design, approvals, contract assembly, utility relocation, needed right of way, advertisement, award, construction, and maintenance review comments for a project. A Project File is completed for all projects and is retained by the region office responsible for the project. Responsibility for the project may pass from one office to another during the life of a project, and the Project File follows the project as it moves from office to office. With the exception of the DDP, the Project File may be purged when retention of the construction records is no longer necessary.

See the Project File checklist for documents to be preserved in the Project File:

[www.wsdot.wa.gov/Design/Support.htm](http://www.wsdot.wa.gov/Design/Support.htm)

The **Design Documentation Package (DDP)** is a part of the Project File and preserves the decision documents generated during the design process. In each package, a summary (list) of the documents included is recommended. The DDP documents and explains design decisions, design criteria, and the design process that was followed. The DDP is retained in a permanent retrievable file for a period of 75 years, in accordance with WSDOT records retention policy.

The Basis of Design, Design Parameters, Alternatives Comparison Table, and Design Analyses are tools developed to document WSDOT practical design and decisions. Retain these in the DDP.

Refer to the remainder of this chapter and DDP checklist for documents to be preserved in the DDP. See Design Documentation Package Checklist here:

[www.wsdot.wa.gov/Design/Support.htm](http://www.wsdot.wa.gov/Design/Support.htm)

## 300.04 Project Design Approvals

This section describes WSDOT's project design milestones known as Design Approval and Project Development Approval. They are required approvals regardless of delivery method chosen by WSDOT. Many of the documents listed under these milestones are described further in [300.06](#).

Information pertaining to FHWA approvals and oversight is provided in [300.05](#) which describes Projects of Division Interest (PoDI) which are governed by a separate plan that specifies FHWA and State responsibilities for the project. Documents for projects requiring FHWA review, Design Approval, and Project Development Approval are submitted through the HQ Design Office.

### 300.04(1) Design Approval

When the Project Summary (see [300.06](#)) documents are approved, and the region is confident that the proposed design adequately addresses the purpose and need for the project, a Design Approval should be pursued and granted at this early stage. Early approval is beneficial at this point in the design phase and is most relevant to larger projects with longer PE phases. Design Approval establishes the policy for three years. This is a benefit for longer PE phases in that it avoids design changes due to policy updates during that time and provides consistency when purchasing right of way or producing environmental documentation.

The items below are included in the combined Design Approval/Project Development Approval Package. Design Approval may occur prior to NEPA approval. Generally, Design Approval will not be provided prior to an [Access Revision Report](#) being approved on an Interstate project. Approval levels for design and PS&E documents are presented in [Exhibits 300-1](#) through [300-3](#).

The following items are to be provided for Design Approval. See [300.06](#) for additional information.

- Stamped cover sheet\*
- A reader-friendly [Design Approval memorandum](#) that describes the project
- [Project Vicinity Map](#)
- Project Summary documents
- Basis of Design ([BOD](#)) \*
- Alternatives Comparison Table
- Design Parameter Sheets
- Safety Analysis or [Crash Analysis Report \(CAR\)](#) \*
- [Current Project Design Analysis\(s\)](#) \*
- List of known [Design Analysis documents](#) (contact your ASDE)
- List of known [Maximum Extent Feasible \(MEF\) documents](#) (contact your ASDE)
- Channelization plans, intersection plans, or interchange plans (if applicable)
- Alignment plans and profiles (if project significantly modifies either the existing vertical or horizontal alignment)
- Current cost estimate

\* [Include the original approved documents](#)

Design Approval is entered into the Design Documentation Package and remains valid for three years or as approved by the HQ Design Office.

- If the project is over this three-year period and has not advanced to Project Development Approval, evaluate policy changes or revised design criteria that are adopted by the department during this time to determine whether these changes would have a significant impact on the scope or schedule of the project.
- If it is determined that these changes will not be incorporated into the project, document this decision with a memo from the region Project Development Engineer that is included in the DDP.
- For an overview of design policy changes, consult the Detailed Chronology of Design Manual revisions: [www.wsdot.wa.gov/design/policy/default.htm](http://www.wsdot.wa.gov/design/policy/default.htm)

### 300.04(1)(a) Design-Build Projects

Design Approval applies to design-build projects and is required prior to issuing a design-build request for proposal (RFP).

Environmental documentation completion is recommended prior to issuing RFP, but is required prior to contract execution.

### 300.04(2) Project Development Approval

When all project development documents are completed and approved, Project Development Approval is granted by the approval authority designated in [Exhibit 300-1](#). The Project Development Approval becomes part of the DDP.

Refer to this chapter and the DDP checklist for design documents that may lead to Project Development Approval. Exhibits [300-1](#) through [300-3](#) provide approval levels for project design and PS&E documents.

The following items must be approved prior to Project Development Approval:

- Stamped cover sheet
- A reader friendly Project Development Approval (PDA) Memorandum that describes the project
- Project Vicinity Map
- Design Approval documents (and any supplements)
  - Updated Basis of Design (BOD) \*
  - Updated list of Project Design analysis(s) \*
  - Updated cost estimate
- NEPA Approvals
- SEPA Approvals

\* Include the original approved documents

Project Development Approval remains valid for three years.

- Evaluate policy changes or revised design criteria that are adopted by the department during this time to determine whether these changes would have a significant impact on the scope or schedule of the project.
- If it is determined that these changes will not be incorporated into the project, document this decision with a memo from the region Project Development Engineer that is included in the DDP.

- For an overview of design policy changes, consult the Detailed Chronology of Design Manual revisions: [www.wsdot.wa.gov/design/policy/default.htm](http://www.wsdot.wa.gov/design/policy/default.htm)

### **300.04(2)(a) Design-Build Projects**

For design-build projects, the design-builder shall refer to the project Request for Proposal (RFP) for specification on final and intermediate deliverables and final records for the project. Project Development Approval is required prior to project completion.

It is a prudent practice to start the compilation of design documentation early in a project and to acquire Project Development Approval before the completion of the project. At the start of a project, it is critical that WSDOT project administration staff recognize the importance of all required documentation and how it will be used in the design-build project delivery process.

## **300.05 FHWA Oversight and Approvals**

The March 2015 Stewardship & Oversight (S&O) [Agreement](#) between WSDOT and FHWA Washington Division created new procedures and terminology associated with FHWA oversight and approvals. One such term, and new relevant procedure, is “Projects of Division Interest” (PoDI) described below.

For all projects, on the National Highway System (NHS), the level of FHWA oversight and approvals can vary for numerous reasons such as type of project, the agency doing the work, PoDI/non-PoDI designation, and funding sources. Oversight and funding do not affect the level of design documentation required for a project.

Documents for projects requiring FHWA review, Design Approval, and Project Development Approval are submitted through the HQ Design Office.

### **300.05(1) FHWA Projects of Division Interest (PoDI)**

Projects of Division Interest (PoDI) are a primary set of projects for which FHWA determines the need to exercise oversight and approval authority. These are projects that have an elevated risk, contain elements of higher risk, or present a meaningful opportunity for FHWA involvement to enhance meeting program or project objectives. Collaborative identification of these projects allows FHWA Washington Division to concentrate resources on project stages or areas of interest. It also allows WSDOT to identify which projects are PoDIs and plan for the expected level of engagement with FHWA.

The Stewardship & Oversight Agreement generally defines Projects of Division Interest as:

- Major Projects (A federal aid project with total cost >\$500M)
- TIGER Discretionary Grant Projects
- NHS Projects that may require FHWA Project or Program Approvals
- Projects Selected by FHWA based on Risk or Opportunity

The S&O Agreement also states: Regardless of retained project approval actions, any Federal-aid Highway Project either on or off the NHS that the Division identifies as having an elevated level of risk can be selected for risk-based stewardship and oversight and would then be identified as a PoDI.

For each project designated as a PoDI, FHWA and WSDOT prepare a Project-Specific PoDI Stewardship & Oversight Agreement which identifies project approvals and related responsibilities specific to the project.

### **300.05(2) FHWA Approvals on Non-PoDI Projects**

On projects that are not identified as PoDI, FHWA approvals are still required for various items as shown in [Exhibit 300-1](#). For example, FHWA approval is still required for any new or revised access point (including interchanges, temporary access breaks, and locked gate access points) on the Interstate System, regardless of funding source or PoDI designation (see [Chapter 550](#)).

The [Exhibit 300-1](#) approval table refers to New/Reconstruction projects on the Interstate. New/Reconstruction projects include the following types of work:

- Capacity changes: add a through lane, convert a general-purpose (GP) lane to a special-purpose lane (such as an HOV or HOT lane), or convert a high-occupancy vehicle (HOV) lane to GP.
- Other lane changes: add or eliminate a collector-distributor or auxiliary lane. (A rural truck climbing lane that, for its entire length, meets the warrants in Chapter 1270 is not considered new/reconstruction.)
- New interchange.
- Changes in interchange type such as diamond to directional or adding a ramp.
- New or replacement bridge (on or over, main line, or interchange ramp).
- New Safety Rest Areas Interstate.

Documents for projects requiring FHWA review, Design Approval, and Project Development Approval are submitted through the HQ Design Office.

### **300.06 Project Documents and Approvals**

This section lists several major design documents generated for a project and they all are retained in the Design Documentation Package. The Basis of Design, Alternatives Comparison Table, Design Parameters, and Design Analyses are tools used to document practical design decisions.

See the Project File and Design Documentation Package checklists described in 300.03(3) for complete list of documents.

For approval levels see Exhibits [300-1](#) through [300-3](#) or a project-specific S&O Agreement for PoDI projects.

#### **300.06(1) Project Summary**

The Project Summary provides information on the results of the scoping phase; links the project to the Washington State Highway System Plan and the Capital Improvement and Preservation Program (CIPP); and documents the design decisions, the environmental classification, and agency coordination. The Project Summary is developed and approved before the project is funded for design and construction, and it consists of the ERS, and PD documents. The Project Summary database contains specific online instructions for completing the documents.

### **300.06(1)(a) Project Definition (PD)**

The PD identifies the various disciplines and design elements that are anticipated to be encountered in project development. It also states the purpose and need for the project, the program categories, and the recommendations for project phasing. The PD is initiated early in the scoping phase to provide a basis for full development of the ERS, schedule, estimate, Basis of Estimate, and Basis of Design (where indicated in scoping instructions). If circumstances necessitate a change to an approved PD, the project manager and the regional program manager will document the change according to the CPDM Change Management process. For more information, see the [Program Management Manual](#), Chapter 9 Managing Change.

### **300.06(1)(b) Environmental Review Summary (ERS)**

The ERS lists the potentially required environmental permits and approvals, environmental classifications, and environmental considerations. The ERS is prepared during the scoping phase and is approved by the region. If there is a change in the PD, the information in the ERS must be reviewed and revised to match the rest of the Project Summary. For actions classified as a CE under NEPA, the approved ERS becomes the ECS when the project is funded and moves to design. The region may revise the ECS as appropriate (usually during final design) as the project advances. The ECS serves as the NEPA environmental documentation for CE projects. The region Environmental Manager approves the ECS and may send it to FHWA for their approval. The ERS/ECS database includes fully integrated help screens that provide detailed guidance. Contact your region Environmental Office for access.

### **300.06(2) Basis of Design (BOD)**

The BOD captures important decisions that control the outcome of a project, including identified performance needs, context, design controls and design elements necessary to design the practical alternative. When applicable attach supporting documents, such as the Alternatives Comparison Table and Design Parameters to the BOD. (See [Chapter 1100](#) for further discussion on these documents). The Basis of Design (BOD) is part of the DDP.

### **300.06(3) Basis of Estimate (BOE)**

The BOE contains the assumptions, risks, and information used to develop an estimate. The BOE is reviewed and updated during each phase of a project. The confidence of the estimate, either overall or for particular items, is also identified within the BOE. Generally, the BOE is started during the scoping phase because it is required for Project Summary approval; however, in more complex situations the BOE may have begun during the planning phase. For more information, see the [Cost Estimating Manual for WSDOT Projects](#).

### **300.06(4) Design Analysis**

A Design Analysis is a process and tool used to document important design decisions, summarizing information needed for an approving authority to understand and support the decision.

A Design Analysis is required where a dimension chosen for a design element that will be changed by the project is outside the range of values provided for that element in the *Design Manual*. A Design Analysis is also required where the need for one is specifically referenced in the *Design Manual*.

A region approved Design Analysis is required if a dimension or design element meets current AASHTO guidance adopted by the Federal Highway Administration (FHWA), such as A Policy on Geometric Design of Highways and Streets, but is outside the corresponding *Design Manual* criteria. See [Exhibit 300-1](#) for Design Analysis approval authorities.

In the case of a shoulder width reduction at an existing bridge pier or abutment, sign structure or luminaire base in a run of median barrier, the Design Parameter Sheet may be used instead of a Design Analysis to document the dimensioning decision for the shoulder at that location.

A template is available to guide the development of the Design Analysis document here:

[www.wsdot.wa.gov/design/support.htm](http://www.wsdot.wa.gov/design/support.htm).

Email a PDF copy of all Region approved Design Analyses to the ASDE supporting your region.

### 300.07 Process Review

The Assistant State Design Engineers work with the regions on project development and conduct process reviews on projects. The process review is done to provide reasonable assurance that projects are prepared in compliance with established policies and procedures and that adequate records exist to show compliance with state and federal requirements. Process reviews are conducted by WSDOT, FHWA, or a combination of both.

The design and PS&E process review is performed at least once each year by the HQ Design Office. The documents used in the review process are the Design Documentation Package Checklist(s), Basis of Design, Basis of Estimate, the PS&E Review Checklist, and the PS&E Review Summary. These are generic forms used for all project reviews. Copies of these working documents are available for reference when assembling project documentation. The HQ Design Office maintains current copies at: [www.wsdot.wa.gov/design/support.htm](http://www.wsdot.wa.gov/design/support.htm).

Each project selected for review is examined completely and systematically beginning with the scoping phase (including planning documents) and continuing through contract plans and, when available, construction records and change orders. Projects are normally selected after contract award. For projects having major traffic design elements, the HQ Traffic Operations Office is involved in the review. The WSDOT process reviews may be held in conjunction with FHWA process reviews.

The HQ Design Office schedules the process review and coordinates it with the region and FHWA.

#### 300.07(1) Process Review Agenda

When conducting joint process review with FHWA, the Process Review Report will outline specific agenda items.

A WSDOT process review follows this general agenda:

1. Review team meets with region personnel to discuss the objective of the review.
2. Review team reviews the design and PS&E documents, construction documents, and change orders (if available) using the checklists.
3. Review team meets with region personnel to ask questions and clarify issues of concern.
4. Review team meets with region personnel to discuss findings.



5. Review team submits a draft report to the region for comments and input.
6. If the review of a project shows a serious discrepancy, the region design authority is asked to report the steps that will be taken to correct the deficiency.
7. Process review summary forms are completed.
8. Summary forms and checklists are evaluated by the Director & State Design Engineer, Development Division.
9. Findings and recommendations of the Director & State Design Engineer, Development Division, are forwarded to the region design authority for action and/or information within 30 days of the review.

## 300.08 References

### 300.08(1) Federal/State Laws and Codes

[23 Code of Federal Regulations \(CFR\) 635.111](#), Tied bids

[23 CFR 635.411](#), Material or product selection

[Revised Code of Washington \(RCW\) 47.28.030](#), Contracts – State forces – Monetary limits – Small businesses, minority, and women contractors – Rules

[RCW 47.28.035](#), Cost of project, defined

“Washington Federal-Aid Stewardship Agreement,”

[www.wsdot.wa.gov/publications/fulltext/design/ASDE/2015\\_Stewardship.pdf](http://www.wsdot.wa.gov/publications/fulltext/design/ASDE/2015_Stewardship.pdf)

### 300.08(2) Design Guidance

WSDOT Directional Documents Index, including the one listed below:

<http://www.wsdot.wa.gov/publications/policies>

[Executive Order E 1010](#), “Certification of Documents by Licensed Professionals,” WSDOT

WSDOT technical manuals, including those listed below:

[www.wsdot.wa.gov/publications/manuals/index.htm](http://www.wsdot.wa.gov/publications/manuals/index.htm)

- *Advertisement and Award Manual*, M 27-02, WSDOT
- *Cost Estimating Manual for WSDOT Projects*, M 3034, WSDOT
- *Design Manual*, M 22-01, WSDOT
- *Emergency Relief Procedures Manual*, M 3014, WSDOT
- *Environmental Manual*, M 31-11, WSDOT
- *Hydraulics Manual*, M 23-03, WSDOT
- *Highway Runoff Manual*, M 31-16, WSDOT
- *Plans Preparation Manual*, M 22-31, WSDOT
- *Roadside Manual*, M 25-30, WSDOT
- *Roadside Policy Manual*, M 3110, WSDOT
- *Temporary Erosion and Sediment Control Manual*, M 3109, WSDOT



Limited Access and Managed Access Master Plan, WSDOT

[www.wsdot.wa.gov/design/accessandhearings/](http://www.wsdot.wa.gov/design/accessandhearings/)

Program Management Manual, M 3005, WSDOT

<http://wwwi.wsdot.wa.gov/publications/manuals/fulltext/M3005/PMM.pdf>

Washington State Highway System Plan, WSDOT

[www.wsdot.wa.gov/planning/](http://www.wsdot.wa.gov/planning/)

### **300.08(3) Supporting Information**

*A Policy on Geometric Design of Highways and Streets* (Green Book), AASHTO, 2011

*Mitigation Strategies for Design Exceptions*, FHWA, July 2007. This publication provides detailed information on design exceptions and mitigating the potential adverse impacts to highway safety and traffic operations.

*Highway Capacity Manual* (HCM), latest edition, Transportation Research Board, National Research Council

*Highway Safety Manual* (HSM), AASHTO

## Exhibit 300-1 Approval Authorities

Project Type	Basis of Design (BOD) Approval	Design Analysis Approval [1] [2] [11]	Design Approval and Project Development Approval
Project of Division Interest (PoDI)	[10]	[10]	[10]
<b>Interstate</b>			
New/Reconstruction Regardless of funding source [3]	FHWA	FHWA	FHWA [4]
Intelligent Transportation Systems (ITS) Improvement Project over \$1 million Preservation project	HQ Design HQ Design	HQ Design HQ Design	HQ Design Region
All Other Regardless of funding source [12]	HQ Design	HQ Design	Region
<b>National Highway System (NHS)</b>			
Projects on all limited access highways, or on managed access highways outside of incorporated cities and towns	HQ Design	HQ Design [5]	Region
Projects on managed access highways within incorporated cities and towns Inside curb or EPS [6][7] Outside curb or EPS	HQ Design City/Town	HQ Design HQ LP	Region City/Town
<b>Non-National Highway System (Non-NHS)</b>			
Improvement projects on all limited access highways, or on managed access highways outside of incorporated cities and towns	HQ Design	HQ Design	Region
Improvement projects on managed access highways within incorporated cities and towns [9] Inside curb or EPS [6][7] Outside curb or EPS	HQ Design City/Town	HQ Design HQ LP	Region City/Town
Preservation projects on limited access highway, or on managed access highways outside of incorporated cities and towns, or within unincorporated cities and towns [8]	Region	Region	Region
Preservation projects on managed access highways within incorporated cities and towns [8] Inside curb or EPS [6][7] Outside curb or EPS	Region City/Town	Region HQ LP	Region City/Town

FHWA = Federal Highway Administration

HQ = WSDOT Headquarters

HQ LP = WSDOT Headquarters Local Programs Office

EPS = Edge of paved shoulder where curbs do not exist

NHS = National Highway System

[www.wsdot.wa.gov/mapsdata/travel/hpms/NHSRoutes.htm](http://www.wsdot.wa.gov/mapsdata/travel/hpms/NHSRoutes.htm)

For table notes, see the following page.

**Exhibit 300-1 Approval Authorities (continued)****Notes:**

- [1] These approval levels also apply to Design Analysis processing for local agency and developer work on a state highway.
- [2] See [300.06\(4\)](#). Where still encountered in the *Design Manual* replace the term *deviation* with *Design Analysis*.
- [3] For definition of New/Reconstruction, see [300.05\(2\)](#).
- [4] FHWA will provide Design Approval prior to NEPA Approval, but will not provide Project Development Approval until NEPA is complete.  
[http://www.wsdot.wa.gov/publications/fulltext/design/ASDE/2015\\_Stewardship.pdf](http://www.wsdot.wa.gov/publications/fulltext/design/ASDE/2015_Stewardship.pdf)
- [5] For guidance on the need for Design Analyses related to access management, see Chapters [530](#) and [540](#).
- [6] Includes raised medians (see [Chapter 1600](#)).
- [7] Curb ramps are still included (see [Chapter 1510](#)).
- [8] For Bridge Replacement projects in the Preservation program, follow the approval level specified for Improvement projects.
- [9] Refer to [RCW 47.24.020](#) for more specific information about jurisdiction and responsibilities that can affect approvals.
- [10] Projects of Division Interest (PoDI) must receive FHWA approvals per the PoDI Agreement regardless of funding source or project type.
- [11] A region approved Design Analysis is required if a dimension or design element meets current AASHTO guidance adopted by the Federal Highway Administration (FHWA), such as *A Policy on Geometric Design of Highways and Streets*, but is outside the range of corresponding *Design Manual* criteria. Email a PDF copy of all Region approved Design Analyses to the ASDE supporting your region.
- [12] Reduction of through lane or shoulder widths (regardless of project type) requires FHWA review and approval, except shoulder reductions for existing bridge pier or abutment, sign structure or luminaire base in a run of median barrier as allowed by [300.06\(4\)](#).

## Exhibit 300-2 Approvals

Item	Approval Authority		
	Region	HQ	FHWA
<b>Program Development</b>			
Work Order Authorization		X	X [1]
<b>Public Hearings</b>			
Corridor Hearing Summary		X [2]	
Design Hearing Summary		X [3]	X [8]
Limited Access Hearing Plan		X [4]	
Limited Access Findings and Order		X [5]	
<b>Environmental Document</b>			
Class I NEPA (EIS)		[7]	X
SEPA (EIS)		X	
Class II NEPA – Categorical Exclusion (CE) Documented in ECS form	X		
SEPA – Categorical Exemption (CE)	X		
Class III NEPA – Environmental Assessment (EA)		[7]	X
SEPA Environmental Checklist & Determination of Non-Significance (DNS)	X		
<b>Design</b>			
Basis of Design (BOD)	[9]	[9]	[9]
Intersection Control Type	X [20]	X [22]	
Experimental Features		X	X
Environmental Review Summary	X		
Final Project Definition		X [10]	
Interstate <u>Access Revision</u> Report		[7]	X
Any Break in Interstate Limited Access		[7]	X
Non-Interstate <u>Access Revision</u> Report		X	
Break in Partial or Modified Limited Access		X	
Intersection or Channelization Plans	X		
Right of Way Plans	[11]	X	
Monumentation Map	X		
Materials Source Report		X [12]	
Pavement Determination Report		X [12]	
Roundabout Geometric Design (see <a href="#">Chapter 1320</a> for guidance)	X		
Resurfacing Report		X [12]	
Signal Permits	X [13]		
Geotechnical Report		X [12]	
Tied Bids	X [14]		

Table continued on the following page, which also contains the notes.

## Exhibit 300-2 Approvals (continued)

Item	Approval Authority		
	Region	HQ	FHWA
Bridge Design Plans (Bridge Layout)	X	X	
Preliminary Bridge Plans for Unusual/Complex Bridges on the Interstate		[7]	X
Structures Requiring TS&Ls		X	
Hydraulic Report	X [15]	[15]	
Preliminary Signalization Plans		X [6][18]	
Signalization Plans	X [20]		
Illumination Plans	X [20]		
Intelligent Transportation System (ITS) Plans	X [20]		
ITS Systems Engineering Analysis Worksheet (Exhibit 1050-2)	X [20]		
Rest Area Plans		X	
Roadside Restoration Plans	X [16]	X [17]	
Planting Plans	X [16]	X [17]	
Grading Plans	X		
Continuous Illumination – Main Line		X [18]	
Tunnel Illumination		X [18]	
High Mast Illumination		X [18]	
Work Zone Transportation Management Plan/Traffic Control Plan	X [20]		
Public Art Plan – Interstate (see Chapter 950)	X [16]	X [17][21]	X
Public Art Plan – Non-Interstate (see Chapter 950)	X [16]	X [17][21]	
Crash Analysis Report	X [20]	X	
ADA Maximum Extent Feasible Document (see Chapter 1510)	X	X	
<p><b>Notes:</b></p> <p>[1] Federal-aid projects only.</p> <p>[2] Approved by Assistant Secretary, Engineering &amp; Regional Operations.</p> <p>[3] Approved by Director &amp; State Design Engineer, Development Division.</p> <p>[4] Approved by Right of Way Plans Manager.</p> <p>[5] Refer to Chapter 210 for approval requirements.</p> <p>[6] Final review &amp; concurrence required at the region level prior to submittal to approving authority.</p> <p>[7] Final review &amp; concurrence required at HQ prior to submittal to approving authority.</p> <p>[8] On Interstate projects, the Director &amp; State Design Engineer, Development Division, (or designee) submits the approved design hearing summary to the FHWA for federal approval. (See Chapter 210.)</p> <p>[9] See Exhibit 300-1 for BOD Approvals.</p> <p>[10] Approved by HQ Capital Program Development and Management (CPDM).</p> <p>[11] Certified by the responsible professional licensee.</p> <p>[12] Submit to HQ Mats Lab for review and approval.</p> <p>[13] Approved by Regional Administrator or designee.</p> <p>[14] Per 23 CFR 635.111.</p> <p>[15] See the <i>Hydraulics Manual</i> for approvals levels.</p> <p>[16] Applies to regions with a Landscape Architect.</p> <p>[17] Applies to regions without a Landscape Architect.</p> <p>[18] Approved by State Traffic Engineer.</p> <p>[19] Vacant.</p> <p>[20] Region Traffic Engineer or designee.</p> <p>[21] The State Bridge and Structures Architect reviews and approves the public art plan (see Chapter 950 for further details on approvals).</p> <p>[22] State Traffic Engineer or designee.</p>			

## Exhibit 300-3 PS&amp;E Process Approvals NHS (including Interstate) and Non-NHS

Item	Headquarters or Region Approval Authority
DBE/training goals * **	Office of Equal Opportunity
Right of way certification for federal-aid projects***	Region; HQ Real Estate Services Office or HQ Local Programs Right of Way Manager [7]
Right of way certification for state or local funded projects***	Region; HQ Real Estate Services Office or HQ Local Programs Right of Way Manager
Railroad agreements	HQ Design Office
Work performed for public or private entities *	Region [1][2]
State force work *	Region [3][4]
Use of state-furnished materials *	Region [3][4]
Work order authorization	Capital Program Development and Management [5]
Ultimate reclamation plan approval through DNR	Region
Proprietary item use *	[4][6] HQ Design Office
Mandatory material sources and/or waste sites *	Region [4]
Nonstandard bid item use *	Region
Incentive provisions	HQ Construction Office
Nonstandard time for completion liquidated damages *	HQ Construction Office
Interim liquidated damages *	<u>Transportation Data, GIS &amp; Modeling Office</u>
<p><b>Notes:</b>  <b>FHWA PS&amp;E Approval has been delegated to WSDOT unless otherwise stated differently in a Project Specific PoDI S&amp;O Agreement.</b></p> <p>[1] This work requires a written agreement.  [2] Region approval subject to \$250,000 limitation.  [3] Use of state forces is subject to \$60,000 limitation and \$100,000 in an emergency situation, as stipulated in RCWs 47.28.030 and 47.28.035. Region justifies use of state force work and state-furnished materials and determines if the work is maintenance or not. HQ CPDM reviews to ensure process has been followed.  [4] Applies only to federal-aid projects; however, document for all projects.  [5] Prior FHWA funding approval required for federal-aid projects.  [6] The HQ Design Office is required to certify that the proprietary product is either: (a) necessary for synchronization with existing facilities, or (b) a unique product for which there is no equally suitable alternative.  [7] For any federal aid project FHWA only approves Right of Way Certification 3s (All R/W Not Acquired), WSDOT approves Right of Way Certification 1s and 2s for all other federal aid projects.</p> <p><b>References:</b>  * <a href="#">Plans Preparation Manual</a>  ** <a href="#">Advertisement and Award Manual</a>  *** <a href="#">Right of Way Manual</a></p>	

**Exhibit 300-4 Design to Construction Transition Project Turnover Checklist Example**

This checklist is recommended for use when coordinating project transition from design to construction.

**1. Survey**

- End areas (cut & fill)
- Staking data
- Horizontal/Vertical control
- Monumentation/Control information

**2. Design Backup**

- Index for all backup material
- Backup calculations for quantities
- Geotech shrink/swell assumptions
- Basis of Design, Design decisions and constraints
- Approved Design Analyses
- Hydraulics/Drainage information
- Clarify work zone traffic control/workforce estimates
- Geotechnical information (report)
- Package of as-builts used (which were verified) and right of way files
- Detailed assumptions for construction CPM schedule (working days)
- Graphics and design visualization information (aerials)
- Specific work item information for inspectors (details not covered in plans)
- Traffic counts
- Management of utility relocation

**3. Concise Electronic Information With Indices**

- Detailed survey information (see Survey above)
- Archived InRoads data
- Only one set of electronic information
- "Storybook" on electronic files (what's what)
- CADD files

**4. Agreements, Commitments, and Issues**

- Agreements and commitments by WSDOT
- RES commitments
- Summary of environmental permit conditions/commitments
- Other permit conditions/commitments
- Internal contact list
- Construction permits
- Utility status/contact
- Identification of the work elements included in the Turnback Agreement (recommend highlighted plan sheets)

**5. Construction Support**

- Assign a Design Technical Advisor (Design Lead) for construction support

An expanded version of this checklist is available at: [www.wsdot.wa.gov/design/projectdev](http://www.wsdot.wa.gov/design/projectdev)





- design is identified, WSDOT may require a new VE analysis or an update to the previous VE analysis; or
- b. If a project's estimated cost was below the criteria identified above but the project advances to construction advertisement, and a substantial change occurs to the project's scope or design, causing an increase in the project cost so that it meets the criteria identified above and results in a required re-evaluation of the environmental document, WSDOT requires that a VE analysis be conducted.
6. When the design of a project has been completed but the project does not immediately proceed to construction, the requirement to conduct a VE analysis is considered to be satisfied, or not necessary, if:
- a. A project met the criteria identified above and had a VE analysis conducted, and the project advances to advertisement for construction without any substantial changes in its scope or its design; or
  - b. A project's estimated cost initially fell below the criteria identified above, but when advancing to advertisement for construction, falls above the criteria due to inflation, standard escalation of costs, or minor modifications to the project's design or contract.

Other projects that should be considered for value engineering have a total estimated cost exceeding \$5 million and include one or more of the following:

- Alternative solutions that vary the scope and cost
- New alignment or bypass sections
- Capacity improvements that widen the existing highway
- Major structures
- Interchanges
- Extensive or expensive environmental or geotechnical requirements
- Materials that are difficult to acquire or that require special efforts
- Inferior materials sources
- New/Reconstruction projects
- Major traffic control requirements or multiple construction stages

### **310.02(3) VE Analysis Timing**

#### **310.02(3)(a) When to Conduct the VE Analysis**

Timing is very important to the success of the VE analysis. A VE analysis should be coordinated with other project development activities. For example, a project requiring an Access Revision Report (ARR), NEPA and a VE should consider how to best integrate the processes with development of project need statements.

Optimizing the timing of a VE analysis minimizes impacts of approved recommendations on previous commitments (agency, community, or environmental) and project's scope. VE analyses can also be coordinated with project risk assessments.

See [www.wsdot.wa.gov/design/saeo/](http://www.wsdot.wa.gov/design/saeo/)

Benefits can be realized by performing a VE analysis at any time during project development; however, the WSDOT VE program identifies the following three windows of opportunity for performing a VE analysis.

### 1. Scoping Phase

Early in preliminary engineering is a good time for value analysis consideration. This is a time to consider alternatives or design solutions with a high potential for implementing VE recommendations. At the conclusion of the VE study, the project scope, preliminary costs, and major design decisions are informed by the recommendations.

When conducting value engineering during the scoping phase of a project, the VE analysis focuses on project drivers. This stage often provides an opportunity for community engagement and building consent with stakeholders.

### 2. Start of Design

At the start of design, the project scope and preliminary costs have been established and major design decisions have been made. Some Plans, Specifications, and Estimates (PS&E) activities may have begun, and coordination with support groups and subject matter experts is underway. At this stage, the project scope, costs, and schedule define the limits of the VE analysis. There is opportunity to focus on the technical issues of the design elements.

### 3. Design Approval

After Design Approval, most of the important project decisions have been made and the opportunity to affect the design is limited. Provided there is time to incorporate VE recommendations, the VE analysis may likely focus on constructability, construction sequencing, staging, traffic control, and significant design issues.

An additional VE analysis may be beneficial late in the development stage when the estimated cost of the project exceeds the project budget. The value engineering process can be applied to the project to lower the cost while maintaining the value and quality of the design.

## 310.02(4) *VE Program Roles and Responsibilities*

### 310.02(4)(a) **Region VE Coordinator**

- Identifies region projects for VE analyses (from Project Summaries and available planning documents).
- Makes recommendations for timing of the VE analysis for each project.
- Presents a list of the identified projects to region management to prioritize into a regional annual VE Plan.
- Identifies potential team facilitators and members for participation statewide.

### 310.02(4)(b) **State VE Manager**

- Reviews regional VE Plans regarding content and schedule.

### 310.02(4)(c) **State VE Coordinator**

- Incorporates the regional annual VE Plans and the Headquarters Plan to create the Statewide VE Plan.
- Prepares annual VE Report.
- Maintains policy documents for the department.
- Coordinates studies.

- 320.01 General
- 320.02 Design Year and Forecasting Considerations
- 320.03 Traffic Analysis Software
- 320.04 Travel Demand Forecasting
- 320.05 Traffic Impact Analysis (TIA)
- 320.06 TIA Scope
- 320.07 TIA Methods and Assumptions Document
- 320.08 TIA Methodologies
- 320.09 TIA Mitigation Measures
- 320.10 TIA Report
- 320.11 References

### 320.01 General

This chapter is intended to address policy-related issues associated with Washington State Department of Transportation (WSDOT) multimodal traffic analysis. It is not intended to address the specifics of demand forecasting; mesoscopic, analytical/deterministic, stochastic microsimulation; or safety performance analyses. For those items, see the latest versions of the *Highway Capacity Manual*, *Traffic Analysis Procedures Manual* (TAPM), and *Highway Safety Manual* (HSM).

Traffic analysis is intended to produce information for decision makers; it is not intended as a stand-alone tool for making decisions. Consideration of empirical data, similar traffic situations, studies, local knowledge, and seasoned traffic engineering and planning experience can also add to a pool of traffic information that is provided to decision makers.

Traffic analysis is either “operational” or “planning” in nature. Operational analysis is associated with engineering concepts focusing on near-term or existing/opening year, while planning analyses are generally focused on a horizon year or interim phase years. Planning-level analyses are also used to determine impacts for environmental documentation phases of Environmental Assessment (EA) or Environmental Impact Statement (EIS) work. Much caution should be used when operational tools are used with planning-level future year projection data.

Be aware that operational models were not primarily intended for use with planning-level future year projected volumes, but there is a need to understand the difference between proposed future scenarios. Therefore, operational models need to use data from forecasting models, but analysts need to do so with an understanding of the imperfections.

Forecasting demand volumes 20 years into the future can be difficult to do well, so there should be little expectation that intersection turning movement projection-related traffic analyses by themselves will be sufficient to produce actionable designs. Consequently, some future year Measures of Effectiveness (MOEs) such as turn lane queue length should not be considered accurate, but they may be useful when comparing various scenarios if the reported differences are substantial.

With the aforementioned limitations, project-specific traffic volumes, forecasts, and system capacities are used to establish the extent of improvements needed for facilities to operate acceptably from year of opening or through interim phases and, eventually, through to the horizon year; for example:

- Number of general purpose/HOV/HOT lanes
- Length and number of ramp or auxiliary lanes
- Intersection or interchange spacing
- Channelization
- Signal timing
- Right of way needs
- Roundabout design parameters
- Width of sidewalks
- Extent of bike lanes
- Ferry holding lanes

Traffic analysis should examine multimodal access, mobility, and safety objectives; project benefits and costs; development impacts; and mitigation needs.

Not all projects will require the same level of effort. The specific depth and complexity of a traffic analysis will depend on a variety of factors, including:

- Project proponents (federal, tribal, state, local, and private sector)
- Legal requirements (laws, regulations, procedures, and contractual obligations)
- Lead agency
- Purpose or scope of the traffic analysis
- Data availability
- Time of day (am/pm peak hour or other)
- Funding
- ROW availability

For projects that fall under FHWA approval, coordinate with the Headquarters (HQ) Traffic Office for concurrence on traffic analysis details. Other projects can be coordinated through region Traffic offices. (See [Chapter 300](#) for FHWA oversight and approval policy.)

## 320.02 Design Year and Forecasting Considerations

Project evaluation requirements can be (1) focused on near-term functionality, (2) contain interim phases, and/or (3) require a long-term focus. The project proponent can be the state (WSDOT or other state agencies) or developers (other public agencies or private concerns).

For Access Revision Reports (ARRs), the design year and multimodal travel demand forecasting methodologies are to be documented by the project stakeholders in the Methods and Assumptions (M&A) Documents.

Guidance on the horizon year and interim design year(s) for projects is given in [Chapter 1103](#), Design Controls.

When selecting horizon year and interim design year phases, stakeholders need to consider the regional significance of a proposed project, how it functions within the existing system, and the expected lifespan. The traffic analysis for developer-related projects will typically focus on existing conditions and the build-out year of the proposed project. Some larger developer projects will need to be evaluated in multiple phases, as they have the potential to significantly impact the transportation system and will thus require a longer-term focus. Mitigation measures may also be phased with these projects.

Project teams are encouraged to consider the strategic importance, economic potential, network constraints, and investment scale when determining the analysis methodologies for project phasing, design year, and forecasts. With acceptance/concurrence by the Traffic Office of purview,<sup>1</sup> the following are possible approaches to be used individually or in concert to develop future year demand volumes:

- Travel demand models
- Trend line projections
- Cumulative impacts
- Limitations of the surrounding network

### 320.03 Traffic Analysis Software

With acceptance by the Traffic Office of purview, use the least complex and data-intensive software deemed reasonable for any given project. Agreement for software and versions must be documented in the study's M&A. Use the latest version sanctioned by WSDOT HQ Traffic.

- For near-term analysis of locations that do not require an understanding of interactions between various transportation systems, Sidra, Rodel, Synchro, and HCS are the primary analytical tools.
- For systemwide multimodal complex forecasting, EMM3, TransCad, and Visum are the primary tools.
- For choosing between scenarios involving multimodal traffic and/or where various transportation system elements interact, CORSIM, Vissim, or Dynameq are the primary tools.

The software mentioned above may have version limitations due to WSDOT purchased rights and contract limitations. For details about these and other traffic analysis software used by WSDOT, see the [Traffic Analysis Procedures Manual](#) or contact the region or HQ Traffic Office.

### 320.04 Travel Demand Forecasting

Designers, planners, and analysts need to be aware of the practical limitations of the selected method of multimodal traffic demand forecasting and should consider the impact of demand uncertainty when conducting analyses and drawing conclusions from those analyses. Special attention should be given to any post-processing efforts. For guidance in the selection of analysis methodology, refer to the [Traffic Analysis Procedures Manual](#). Following are brief descriptions of the four main methods for demand forecasting.

---

<sup>1</sup> See [Chapter 300](#) and the Federal-Aid Highway Program Stewardship and Oversight Agreement: Generally, region for non-Highways of Statewide Significance (HSS) or non-National Highway System (NHS), and Headquarters for HSS and NHS.

### **320.04(1) Travel Demand Models**

For the vast majority of projects, this will be the proper approach for developing future year demand volumes. However, caution should be taken when using this approach to draw conclusions from operational model Measures of Effectiveness (MOEs) that are based on such forecasts, because specific and accurate turning movement volumes are needed to produce credible MOEs. Forecast models are most commonly used to produce general volumes that can help traffic planners evaluate and compare the relative merits of potential solutions against each other.

### **320.04(2) Trend Line Projections**

Where travel demand models are not established or are otherwise considered inadequate, trend data can be used but must be constrained by system flow limitations. Trend line growth cannot account for peak spreading when traffic demand exceeds system supply. Use with caution and consult the [HQ Transportation Data & GIS Office](#) (TDGO) for further details about this method and any inherent limitations.

### **320.04(3) Cumulative Impacts**

This method is typically used to forecast volumes in areas that demonstrate uniform growth and exhibit only minor changes and marginal impacts to the region. It is also useful for analyzing growth in suburban areas that are experiencing rapid development, as other methods may not be as reliable. The basic concept is to add volumes for developments to the trending background traffic growth. The comprehensive plan for such areas should be consistent with the expected growth predicted by a project (and include other anticipated projects) in order to result in a reasonable estimate of cumulative impacts. Use with caution due to an inability to fully account for secondary impacts like future environmental issues, local network connectivity, public services, and multimodal demands.

### **320.04(4) Limitations of the Surrounding Network**

For projects that contain infrastructure of particular importance, extraordinary expense, life span expectancy beyond 20 years, or where travel demand will likely always exceed transportation system capacity constraints, give consideration to the concept of facility capacity balancing within the context of the larger transportation system.

This approach needs to demonstrate that the maximum amount of upstream traffic flowing into a project, as well as all project-area traffic flowing into downstream sections, can be handled acceptably. This does not require traditional travel demand forecasting, which has a limitation of about 20 years. Instead, it requires a sensitivity approach where maximum up- and downstream flows are used to right-size the project area's proposed improvements. The simplest example is the SR 520 Floating Bridge: constraints on either end of the bridge limit the usefulness of adding more lanes on the bridge.

TIA's and ARRs (see [Chapter 550](#)) shall clearly describe the methodology and process used to develop forecasts in support of a proposed project's analysis. For example, include only those projects that:

- Are on the six-year Transportation Improvement Plan.
- Are fully funded.
- Have entered the environmental review process.

## 320.05 Traffic Impact Analysis (TIA)

TIA is a term used for all analyses that are not structured [ARRs](#) (see [Chapter 550](#)) or planning-level efforts like corridor studies. The quality and level of service<sup>2</sup> for state-owned and state-interest facilities shall be based upon MOEs that support the project purpose and need. They shall also be developed and presented in accordance with the latest versions of the *Highway Capacity Manual* (HCM), [FHWA Traffic Analysis Toolbox](#), [Traffic Analysis Procedures Manual](#), and WSDOT Vissim Protocol.

For some example MOEs, see the [FHWA MOE List](#), which describes measures typically used for analyzing state and local agency facilities such as freeway segments, signalized intersections, ramp terminals/junctions, sidewalks, and transit services.

Depending on the facility and when HCM Level of Service MOE is used, WSDOT thresholds are “C” for rural and “D” for urban non-NHS facilities, unless a WSDOT region specifies otherwise for specific route segments. (See each WSDOT region for details.) Refer to the [WSDOT State Highway Log](#) for a determination of existing route segment definitions for urban or rural status.

Depending on the project type and purpose, multimodal MOEs may be employed.

### 320.05(1) Updating an Existing TIA

TIAs require either updating or a sensitivity analysis if they become more than 3 years old; however, a TIA will require updating sooner in rapidly developing areas. TIAs can avoid such update efforts in slowly developing areas. To determine if an update is required, an assessment of critical infrastructure functionality must be documented.

If the amount or character of traffic in the study area is significantly different from an earlier analysis, an update will be required. The definition of significant is 10% (volume, flow rate, travel time, delay, density, or other key MOEs) where existing operations are currently acceptable. If they are not currently acceptable, the threshold is reduced to 5%. In cases where greater than 10% change or failed MOEs have been found, consultation and concurrence with WSDOT Traffic Office of purview is required to avoid a full [ARRs](#) or TIA update.

Developer-initiated TIAs are typically valid for 5 or 6 years, as that is the window provided under the Growth Management Act for concurrency. The Development Services Office should be consulted regarding the need for updates to TIAs for developer, tribal, and local agency projects.

## 320.06 TIA Scope

To establish the appropriate scope, consultation between the lead agency, WSDOT, and those preparing the TIA is encouraged before beginning work. TIA-required elements can be found in the [Traffic Analysis Procedures Manual](#) (an abbreviated list is provided below). **Note:** For developer-initiated TIAs, the local agency may prescribe the scope of the TIA per the local agency’s adopted standards.

---

<sup>2</sup> WSDOT sets level of service (LOS) standards for state highways and ferry routes of statewide significance (HSS) based on [RCW 47.06.140\(2\)](#). Regional transportation planning organizations (RTPOs) and WSDOT jointly develop and RTPOs establish LOS standards for regionally significant state highways and ferry routes (non-HSS) based on [RCW 47.80.030\(1\)\(c\)](#).

### 320.06(1) TIA Boundaries

The traffic impacts of local streets and roads can impact intersections on state highway facilities. In these cases, include in the TIA an analysis of adjacent local facilities (driveways, intersections, main lines, and interchanges) upstream and downstream of the intersection with the state highway. A “lesser analysis” may include obtaining traffic counts, preparing signal warrants, or a focused TIA. For developer projects, the boundaries of the analysis (such as the city limits) may be determined in consultation with local agencies and WSDOT. For further guidance, consult the [Traffic Analysis Procedures Manual](#) and [Development Services Manual](#).

### 320.06(2) Traffic Analysis Scenarios

WSDOT must understand the effects of plan updates and amendments, as well as the effects of specific project elements (including site plans, conditional use permits, subdivisions, and rezoning) that have the potential to impact state facilities. Consultation between the lead agency, WSDOT, and those preparing the TIA is essential early in the process to help determine appropriate scenario analyses and goals. For further guidance, consult the [Traffic Analysis Procedures Manual](#) and [Development Services Manual](#).

Depending on the type of work being analyzed, required TIA scenarios can range from simple “existing conditions with and without project,” to more complex analyses where TIA scenarios could include: existing; opening year with and without project; interim years with and without project; and design year with and without project. If developed with WSDOT, and if following ARR guidance, pre-ARR work such as Area Study TIAs can be used in future ARRs.

The appropriate and necessary scenarios shall be agreed upon by the TIA study team and documented in the TIA Methods and Assumptions (M&A) Document.

For existing networks, calibrate models to existing conditions.

If a near-term baseline network is required, only funding-secured projects should be added to the existing network. This is typical of opening year models that are a few years beyond existing year.

For interim scenario networks, include only projects or developments within the forecasting process that have the highest probability within the 10-year horizon. For example, include projects that are fully funded or have a construction phase in the six-year Transportation Improvement Plan.

For scenarios with phases beyond 10 years, TIA or ARR teams should discuss and document the merits of including other potential projects. For example:

- Projects on current long-range regional transportation plans (or the locally-adopted transportation plan, if the TIA is not on a regionally-significant facility)
- Projects on the HSP or MTP



All other potential influences with lower probability should not be allowed to affect travel or trip demand forecast results—with one exception: TIAs and ARRs may include multiple scenarios for the design year. For example, if a major assumption for unfunded additional lanes “feeding traffic into” or “allowing traffic from” the project is desired for the design year to allow for a better understanding of expensive infrastructure sizing (such as ultimate bridge widths), ensure a constrained design year scenario is included so that proper funding-based phasing solutions are communicated.

### 320.07 TIA Methods and Assumptions Document

The TIA M&A is similar to an ARR M&A in that it documents the “who, what, where, when, how, and why” items associated with the traffic analysis portion of a project.

Prior to any substantial fieldwork or traffic/facility data collection, consultation between the lead agency, WSDOT, and those preparing the TIA is encouraged to help reach and document consensus on study data needs and assumptions. These and other items should be documented and the M&A signed by all lead staff that conduct work in association with the TIA M&A document. For further guidance, consult the [Traffic Analysis Procedures Manual](#) and [Development Services Manual](#).

### 320.08 TIA Methodologies

The [FHWA Traffic Analysis Toolbox](#), Volume 2, provides a methodology for selecting traffic analysis tools. However, in general, traffic analysis methodologies for those facility types indicated below are used by WSDOT and will be accepted if agreed upon by those who sign TIA or ARR M&A Documents.

- **Freeway Segments:** *Highway Capacity Manual/Software* (HCM/S); operational and design analysis; macroscopic, mesoscopic, and microsimulation
- **Weaving Areas:** *Design Manual* (DM); HCM/S; operational and design analysis; microsimulation
- **Ramps and Ramp Terminals:** HCM/S; operational and design analysis; DM; microsimulation
- **Multilane Highways:** HCM/S; operational and design analysis; macroscopic, mesoscopic, and microsimulation
- **Two-Lane Highways:** HCM/S; operational and design analysis
- **Intersection, Signalized:** Sidra; Synchro; SimTraffic; HCM/S; Vissim,
- **Intersection, Roundabout:** Sidra; Rodel; HCM; Vissim
- **Corridors:** Sidra; Synchro; SimTraffic; HCM; Vissim
- **Stop-Controlled Intersections:** HCM/S for capacity; DM [Chapter 1330](#) and the [MUTCD](#) for signal warrants (if a signal is being considered)
- **Transit:** HCM/S; operational and design analysis; [Traffic Manual](#)
- **Pedestrians:** HCM/S
- **Bicycles:** HCM/S

- **WSDOT Criteria/Warrants:** [MUTCD](#) (signals, stop signs); [Traffic Manual](#) (school crossings); [DM Chapter 1040](#) (freeway lighting, conventional highway lighting)
- **Channelization:** DM

The procedures in the *Highway Capacity Manual* do not explicitly address operations of closely spaced signalized intersections, nor does WSDOT currently endorse microsimulation or roundabout guidance as noted in the HCM/S. Under such conditions, several unique characteristics must be considered, including spill-back potential from the downstream intersection to the upstream intersection; effects of downstream queues on upstream saturation flow rates; and unusual platoon dispersion or compression between intersections. An example of such closely spaced operations is signalized ramp terminals at urban interchanges. Queue interactions between closely spaced intersections can seriously distort the results of analyses that follow the procedures in the HCM.

Other analysis methods may be accepted; however, consultation between the lead agency, region or HQ Traffic, and those preparing the TIA is encouraged to reach consensus on the data necessary for the analysis if meso- or microsimulation is employed. When a state highway has saturated flows, the use of a meso- or microsimulation models can provide additional understanding. Note, however, that the simulation model must be calibrated and validated for reliable results and is intended for near-term operational analyses (see the [Traffic Analysis Procedures Manual](#) for guidance on calibration and validation).

Operational MOEs for simulation models based on long-term forecasts should be used primarily to determine which scenarios are better than others. The models can only do so if the resultant MOEs demonstrate significant differentiation between scenarios. TIA or ARR teams will determine what is considered significant and will document those findings in the study. However, at a minimum, significant must be greater than the expected error band of the models used. For example, if Vissim is considered to be calibrated to a given MOE within 15% of existing conditions (a very wide band), the scenarios need to show greater than 15% differentiation between each other to be significant.

### 320.09 TIA Mitigation Measures

Consultation between the lead agency, WSDOT, and the responsible parties preparing the TIA is recommended in order to reach consensus on the project mitigation measures. Mitigation measures, if applicable, need to be included in the TIA to determine whether a project's impacts can be eliminated or reduced to a level of insignificance. Eliminating or reducing impacts to a level of insignificance is the standard pursuant to the State Environmental Policy Act (SEPA) and National Environmental Policy Act (NEPA). The lead agency is responsible for administering the SEPA and/or NEPA review process. WSDOT is responsible for reviewing the TIA for impacts that pertain to state highway facilities. However, the authority vested in the lead agency under SEPA/NEPA does not take precedence over other authorities in law.

Development work in the state highway right of way requires a WSDOT permit or agreement. Normally, this work is coordinated by the region Development Services Office.

Mitigation measures may take the following forms:

- Channelization such as turn lanes or raised islands
- Installation of a roundabout or, if necessary, a traffic signal (signal warrant analysis per [MUTCD](#) is required)
- Frontage improvements
- Donation of right of way
- Addressing any design or operational deficiencies created by the proposal
- Possible restrictions of turning movements
- Sight distance enhancements
- Traffic mitigation payment (pro rata share contribution) to a programmed WSDOT project (see Chapter 4 of the [Development Services Manual](#))
- Satisfaction of local agency guidelines and interlocal agreements

## 320.10 TIA Report

### 320.10(1) TIA Minimum Contents

The minimum contents of a TIA report are listed in the [Traffic Analysis Procedures Manual](#) and [Development Services Manual](#). Listed below is a summary; however, the depth and detail of content under each element varies in relation to the scale and complexity of the project.

#### (a) Executive Summary

#### (b) Table of Contents

1. List of Exhibits (Maps)
2. List of Tables

#### (c) Introduction

1. Description of the proposed project with purpose and need.
2. Traffic Impact Analysis Methods and Assumptions summary.
3. Map of project location.
4. Site plan, including all access to state highways (site plan, map).
5. Circulation network, including all access to state highways (vicinity map).
6. Land use and zoning.
7. Phasing plan, including proposed dates of project (phase) completion.
8. Project sponsor and contact person(s).
9. References to other traffic impact studies.
10. Other mitigation measures considered.

**(d) Traffic Analysis**

1. TIA M&A (see the [Traffic Analysis Procedures Manual](#) for a template or the [Development Services Manual](#)).
2. Existing and projected conditions of the site: posted speed; traffic counts (to include turning movements); sight distance; channelization; design analyses; pedestrian and bicycle facilities; design vehicle; and traffic controls, including signal phasing and multi-signal progression where appropriate (exhibit(s)).
3. DHV and ADT; project trip generation and distribution map, including references and a detailed description of the process involved in forecasting the projected trips, including tables.
4. Project-related transportation mode split, with a detailed description of the process involved in determining transportation mode split.
5. Project-generated trip distribution and assignment with a detailed description of the process involved in distributing and assigning the generated traffic, including exhibit(s).
6. If intersection control additions are employed and traffic signals are assumed, include functionality and warrant analyses. With roundabouts or signals, include existing conditions, cumulative conditions, and full-build of plan conditions with and without project.
7. Safety performance analysis (see [Chapter 321](#) and the [Traffic Analysis Procedures Manual](#)).

**(e) Conclusions and Recommendations**

1. Quantified or qualified LOS, QOS, and other appropriate MOEs of impacted facilities with and without mitigation measures.
2. Predicted safety performance with and without mitigation measures.
3. Mitigation phasing plan with dates of proposed mitigation measures.
4. Defined responsibilities for implementing mitigation measures.
5. Cost estimates for mitigation measures and financing plan.

**(f) Appendices**

1. Description of traffic data and how data was collected and manipulated.
2. Description of methodologies and assumptions used in analyses.
3. Worksheets used in analyses; for example, signal warrants, LOS, QOS, and traffic count information.
4. If microsimulation is used, provide a copy of the Confidence and Calibration Report.

## 320.11 References

### 320.11(1) Federal/State Laws and Codes

[42 United States Code 4321](#), National Environmental Policy Act (NEPA) of 1969

[Revised Code of Washington \(RCW\) 43.21C](#), State environmental policy ([Chapter 197-11 WAC](#) and [Chapter 468-12 WAC](#))

[RCW 36.70a](#), Growth Management Act

[RCW 36.70A.070](#), Comprehensive plans – Mandatory elements

[RCW 47.06.140](#), Transportation facilities and services of statewide significance – Level of service standards

[Washington Administrative Code \(WAC\) 365-196-430](#), Transportation elements of comprehensive plans

[Manual on Uniform Traffic Control Devices for Streets and Highways](#), USDOT, FHWA; as adopted and modified by [Chapter 468-95 WAC](#) “Manual on uniform traffic control devices for streets and highways” (MUTCD)

### 320.11(2) Design Guidance

*Design Manual*, [Chapter 321](#), for sustainable safety

*Design Manual*, [Chapter 550](#), for [Access Revision Report](#) guidelines

*Design Manual*, [Chapter 1300](#), for selecting intersection control type

*Design Manual*, [Chapter 1310](#), for intersection guidelines

*Design Manual*, [Chapter 1320](#), for roundabout guidelines

Federal-Aid Highway Program Stewardship and Oversight Agreement:

<http://www.wsdot.wa.gov/nr/rdonlyres/0f8eaddb-7fcc-4ea0-8609-5bca74634ebd/0/fhwawsdotstewardshipagreement.pdf>

*Highway Capacity Manual (HCM)*, latest edition, Transportation Research Board, National Research Council

[Level of Service Standards for Washington State Highways](#)

*Roadside Design Guide* and *A Policy on Geometric Design of Highways and Streets*, latest editions, American Association of State Highway and Transportation Officials (AASHTO)

[Standard Plans for Road, Bridge, and Municipal Construction \(Standard Plans\)](#), M 21-01, WSDOT

[Traffic Analysis Procedures Manual \(TAPM\)](#)

WSDOT Traffic Analysis web page:

<http://www.wsdot.wa.gov/design/traffic/analysis/>

**320.11(3) Supporting Information**

*Development Services Manual*, M 3007.00, WSDOT

FHWA Traffic Analysis Toolbox:

 <http://www.ops.fhwa.dot.gov/trafficanalysisitools/index.htm>

*Traffic Manual*, M 51-02, WSDOT

“Trip Generation,” Institute of Transportation Engineers (ITE)

WSDOT’s Highway Segment Analysis Program

WSDOT’s *Mobility Project Prioritization Process Manual* and Workbook:

 [www.wsdot.wa.gov/mapsdata/travel/mobility.htm](http://www.wsdot.wa.gov/mapsdata/travel/mobility.htm)

WSDOT’s Planning Level Cost Estimation (PLCE) Tool

- 321.01 Sustainable Safety Related Policy
- 321.02 HQ Safety Technical Group
- 321.03 Project Related Safety Analysis
- 321.04 Stand Alone Safety Analysis
- 321.05 Reports and Documentation
- 321.06 References

### 321.01 Sustainable Safety Related Policy

The Washington State Strategic Highway Safety Plan, “Target Zero” has a vision to reduce traffic fatalities and serious injuries to zero by 2030. WSDOT is pursuing this goal along with partners such as Washington State Patrol (WSP) and Washington Traffic Safety Commission (WTSC). WSDOT recognizes that risk exists in all modes of transportation. The universal objective is to reduce the number of fatal and serious injury crashes within the limits of available resources, science, technology, and legislatively mandated priorities.

The *Secretary’s Executive Order E 1085*, Sustainable Highway Safety Program, sets the policy for the Washington State Department of Transportation (WSDOT) to embark on a targeted and scientifically-based Engineering approach for identifying and addressing crash risks that is multimodal and coordinated with the other three “E”s, Education, Enforcement, and Emergency Services. Sustainable Safety employs a “5th E”, Evaluation, this is the analysis and diagnosis of crashes and to target their contributing factors in addressing highway safety performance. Evaluation relies on quantifying safety performance using scientific tools and assessment techniques to determine appropriate safety countermeasures.

Sustainable Safety is the approach to transportation safety at WSDOT through the use of “...tools and procedures based on accepted science, data, and proven practice” in accordance with *Secretary’s Executive Order E 1096*, Agency Emphasis and Expectations, to target safety needs, and “deliver the right solutions at the right time and at the right location.”

Practical Solutions is an approach to making project decisions that focus on resolving the project need for the least cost without adversely impacting safety performance. Sustainable Safety is the approach for resolving safety performance within WSDOT’s Practical Solutions as directed in both *E 1096* and *Secretary’s Executive Order E 1090*, Moving Washington Forward: Practical Solutions.

*E 1085* directs engineers to base project-level decisions on safety analysis of specific locations and corridors and focus on proven lower-cost targeted countermeasures at specific locations that optimize the return on investment of safety dollars. These lower-cost investments allow for additional identified locations to be addressed. Sustainable Safety is therefore an essential part of successful Practical Design implementation. It provides the process and methods to incorporate safety performance assessment and peer-review into Performance-Based Practical Design. Sustainable Safety allows the planner, engineer, and decision maker, to identify and quantify the safety performance of alternatives during project development.

Implementing Sustainable Safety improves WSDOT’s effectiveness in reducing the risk of fatal and serious injury crashes statewide. It focuses on the contributing factors and types of crashes through the use of state-of-the-art principles and analytical methods to diagnose, quantify, and

predict safety performance. The Sustainable Highway Safety Policy directs WSDOT to use effective and efficient resources, like the AASHTO Highway Safety Manual (HSM) to achieve the goals of the Washington State Strategic Highway Safety Plan: Target Zero. This approach:

1. Optimizes the reduction in fatal and serious injury crash potential on Washington's highways.
2. Provides quantifiable assessment of crash potential.
3. Identifies locations that have a higher potential for crash reduction.
4. Provides reliable and accurate assessment of potential crash reduction benefits.
5. Identifies and deploys solutions with optimal benefit/cost within the WSDOT safety priority programming process or through low cost operational improvements.
6. Reduces waste by focusing on design elements that provide a reduction in crash potential.
7. Addresses locations that will result in a higher crash risk reduction potential for a given investment level.
8. Provides an accurate assessment of project and program performance.
9. Provides scientific and engineering tools to continually improve and refine safety analyses.

Sustainable Safety is a critical, integral part of Practical Solutions that supports Washington in reaching its Target Zero goal.

### 321.02 HQ Safety Technical Group

The HQ Safety Technical Group is comprised of experts in safety analysis. The team has several duties including maintaining the Safety Analysis Guide, safety analysis training, review of complex safety analysis, review of Crash Analysis Reports, and approve the use of crash modification factors. The team can also provide assistance to a project office as they conduct safety analysis.

### 321.03 Project Related Safety Analysis

All projects are required to have a safety analysis for Design Approval (see [Chapter 300](#)). The safety analysis is intended to be scalable. The Safety Analysis Guide provides direction on the scope and scale of safety analysis for each funding subprogram (i.e. I-1, I-2, P-3) and each document needing a safety analysis (i.e. Design Analyses, Access Revision Reports (ARRs), Intersection Control Evaluations (ICEs)). Contact the HQ Safety Technical Group if your project is not covered by the Safety Analysis Guide or if you have questions regarding how to use the guide.

### 321.04 Safety Analysis

The [Safety Analysis Guide](#) contains guidance on the content of stand-alone safety analyses for Design Analyses, Crash Analysis Reports (CAR), ICE, Transportation Management Plans, Road Safety Audits, Environmental Impact Statements, and ARRs. Use the procedures described in the WSDOT Safety Analysis Guide when performing a safety analysis. Contact the HQ Safety Technical Group if you have any questions or need to develop a stand-alone safety analysis that is not covered in the Safety Analysis Guide.



## 321.05 Reports and Documentation

The CAR, ICE, and Basis of Design (BOD) utilize safety analysis. They are described in the following subsections. For approval requirements, refer to [Chapter 300](#).

### 321.05(1) *Crash Analysis Report (CAR)*

A CAR is developed during the scoping phase for I-2 Crash Reduction projects and is required for funding to be released. A template of the Crash Analysis Report with instructions is available here: [http://wwwi.wsdot.wa.gov/Planning/CPDMO/PlanningProgrammingSafety\\_I-2.htm](http://wwwi.wsdot.wa.gov/Planning/CPDMO/PlanningProgrammingSafety_I-2.htm)

If a CAR was developed using the template for the 2019-21 biennium or newer, the project does not need a BOD.

### 321.05(2) *Intersection Control Evaluation (ICE)*

Projects that require an ICE need to do a safety analysis on the alternatives. If a project has a completed CAR, the ICE may reference this CAR. If not, the safety analysis for the ICE should have a scale and scope associated with its funding source as noted in the Safety Analysis Guide.

### 321.05(3) *Basis of Design (BOD)*

The BOD utilizes metrics and targets in the baseline and contextual needs. If the chosen metric is safety related utilize a safety analysis to determine the potential for crash reduction for various alternatives. The safety analysis may also be used as a component in the Alternative Comparison Table (ACT) to allow easier comparison across alternatives. The scale and scope of a safety analysis for a BOD is associated with its program type and is explained in the Safety Analysis Guide.

## 321.06 References

### 321.06(1) *Federal/State Directives, Laws, and Codes*

[23 United States Code \(USC\) 148](#) – Federal requirements for the Highway Safety Improvement Program (HSIP)

[Revised Code of Washington \(RCW\) 47.05.010](#) – The statement of purpose for priority programming of transportation projects

[Secretary's Executive Order 1085](#) – Sustainable Highway Safety Program

[Secretary's Executive Order 1090](#) – Moving Washington Forward: Practical Solutions

[Secretary's Executive Order 1096](#) – WSDOT 2015-17: Agency Emphasis and Expectations

### 321.06(2) *Design Guidance*

*Safety Analysis Guide*, WSDOT; See Sustainable Highway Safety Tools here:

<http://www.wsdot.wa.gov/Design/Support.htm>

Highway Safety Manual (HSM), AASHTO, 2010

A Policy on Geometric Design of Highways and Streets (Green Book), AASHTO, 2011

### 321.06(3) Supporting Information

Strategic Highway Safety Plan: Target Zero – Washington State’s strategic traffic safety plan developed by the Washington Traffic Safety Commission: <http://www.targetzero.com/>

Sustainable Highway Safety Internal Web Page – Contains all of the procedures and tools to implement highway safety: <http://wwwi.wsdot.wa.gov/HighwaySafety/>

Washington Transportation Plan – Washington State Transportation Commission’s recommended strategic transportation plan; includes a highway safety element:  
[http://www.wstc.wa.gov/wtp/documents/wtp2030\\_201012.pdf](http://www.wstc.wa.gov/wtp/documents/wtp2030_201012.pdf)

- 530.01 General
- 530.02 Achieving Limited Access
- 530.03 Full Control (Most Restrictive)
- 530.04 Partial Control
- 530.05 Modified Control (Least Restrictive)
- 530.06 Access Approaches
- 530.07 Frontage Roads
- 530.08 Turnbacks
- 530.09 Adjacent Railroads
- 530.10 Access Breaks and Inner Corridor Access
- 530.11 Documentation

## 530.01 General

Limited access control is established to preserve the safety performance and efficiency of specific highways for all modes and to preserve the public investment. Limited access control is achieved by acquiring access rights from abutting property owners and by selectively limiting approaches to a highway, considering all modes in the control and treatment of access. (For an overview of access control and the references list and definitions of terminology for this chapter, see [Chapter 520, Access Control](#).)

Requirements for the establishment of limited access highways are set forth in the [Revised Code of Washington \(RCW\) 47.52](#). The type of access control applied to a location is considered a design control (see [Chapter 1103](#)), and is determined during planning, scoping, or the early stages of design in conformance with this chapter.

Highways controlled by acquiring abutting property owners' access rights are termed limited access highways and are further distinguished as having full, partial, or modified control. The number of access points per mile, the spacing of interchanges or intersections, and the location of frontage roads or local road/street/trail approaches are determined by the:

- Functional classification and importance of the highway
- Context-based modal priorities and relevant considerations
- Character of the traffic
- Current adjacent land use and future planned changes to land use
- Environment and aesthetics
- Highway design, operation, safety and connectivity for all modes
- Economic considerations involved

The Federal Highway Administration (FHWA) has jurisdiction on the Interstate System. The Washington State Department of Transportation (WSDOT) has full jurisdiction on all other limited access highways, whether they are inside or outside incorporated city limits.

WSDOT maintains a record of the status of limited access control, by state route number and milepost, in the Access Control Tracking System Limited Access and Managed Access Master Plan database (Access Master Plan). See the Access and Hearings website: <http://www.wsdot.wa.gov/Design/accessandhearings/>

## 530.02 Achieving Limited Access

### 530.02(1) Evaluation

The benefits of maintaining or acquiring full, partial, or modified control are to be evaluated during project development if the route is shown in the Access Control Tracking System Limited Access and Managed Access Master Plan database as either “established” or “planned” for limited access. It is generally known that full limited access control applies to interstates and freeways. However, state highways that do not fall under full access control may have more flexibility in the type of control applied (whether limited or managed control). These highways can benefit by having access control evaluations conducted early in planning and project development.

The cost of acquiring limited access is evaluated to determine whether those costs will be included in the project. The evaluation includes the societal costs of crashes, current and future land use development, and the improved level of service for motor vehicle traffic of limited access highways. Use the Basis of Design documentation tool to summarize key results of the evaluation process, considering connectivity, mobility, safety and accessibility for all modes. (See chapters in the [1100 series](#) for more information on using the [Basis of Design](#) tool.)

### 530.02(2) Process

All Washington State highways are managed access highways (see [Chapter 540](#)), except where limited access rights have been acquired. The right of way and limited access plans for routes show the acquired limited access boundaries. This is further represented in the Access Control Tracking System, a database that identifies the status and type of access control for all state highways. The database lists the specific types of limited access control (full, partial, or modified) and identifies whether the control is planned, established, or acquired for a specific route segment. If limited access has not been acquired, the database reports the type of managed access classification that currently applies.

The existing access classification is periodically updated to reflect changes on a corridor segment. The planned limited access reflects the vision for access on a corridor by resolution from the Washington Transportation Commission in the 1960s and 1970s. Conditions may have changed since the plan for limited access was envisioned. It is important to re-evaluate this plan and determine the access design control most appropriate for the agreed context. (See [Chapters 1102](#) and [1103](#) for context and design control guidance, respectively.) For help determining the status of limited access control for any state highway, consult the Headquarters (HQ) Access and Hearings Section.

The Access Master Plan database is available at:  
[www.wsdot.wa.gov/design/accessandhearings](http://www.wsdot.wa.gov/design/accessandhearings)

#### 530.02(2)(a) Procedure for Limited Access Control

Use the following procedure to achieve limited access control:

1. The Secretary of Transportation (or a designee) first identifies a highway as “Planned for Limited Access.”
2. To establish or revise limited access on a new or existing highway, either a limited access hearing is held or waivers are obtained. (See [Chapter 210](#), Public Involvement and Hearings,

regarding hearings, and [Chapter 510](#), Right of Way, for the phases of appraisal and acquisition.)

**a. Phase 1**

The region develops a limited access report and a limited access report plan for department approval and presentation to local officials. The plan notes the level of limited access proposed to be established.

**b. Phase 2**

The region develops a limited access hearing plan for Director & State Design Engineer, Development Division (or designee), approval and for presentation at the hearing.

**c. Phase 3**

After the hearing, the region develops the findings and order and revises the limited access hearing plan to become the findings and order plan (see Chapter 210). The findings and order is processed and sent to the HQ Access and Hearings Section for review and approval. The Assistant Secretary, Regions and Mega Programs/Chief Engineer, adopts the findings and order and thus establishes the limits and level of limited access control to be acquired.

**d. Phase 4**

The findings and order plan is now revised by the HQ Right of Way Plans Section for approval by the Director & State Design Engineer, Development Division (or designee), as a Phase 4 final right of way and limited access plan.

3. Real Estate Services acquires limited access rights from individual property owners based on final design decisions and updates the right of way and limited access plans and the property deed.
4. These highways or portions thereof are now limited access highways and no longer fall under the managed access program.

### **530.02(3) Access Report ([RCW 47.52.131](#))**

The Access Report is developed by the region to legally inform local governmental officials of the proposed limited access highway and the principal access features involved, and to secure their approval. This report is not furnished to abutting property owners. Submit the report to the HQ Access and Hearings Section for review and approval prior to submission to local authorities. Including local agencies as stakeholders from the onset of the project helps establish project expectations and positive working relationships, making reviews and approvals run as smoothly as possible.

#### **530.02(3)(a) Access Report Content**

The Access Report consists of the following:

1. A description of the existing and proposed highways, including data on the history of the existing highway, which may include references to safety analyses and also locations identified in WSDOT's priority programming process.
2. Traffic analyses pertaining to the proposed highway, including available information about current and potential future motor vehicle, pedestrian, bicyclist, transit, and freight traffic volumes on county roads and city streets crossing or severed by the proposed highway and reference sources such as origin-destination surveys.

Traffic data, together with counts of existing traffic available from state or local records, is normally adequate for motor vehicle analysis. Special counts of existing traffic are obtained only if circumstances indicate that the available data is inadequate or outdated. Data for pedestrian and bicyclist traffic may rely on demographics, land-use context, and an analysis of the active transportation network where volume information is not available.

3. A discussion of factors affecting the design of the subject highway, including:
  - Functional classification  
[www.wsdot.wa.gov/mapsdata/travel/hpms/functionalclass.htm](http://www.wsdot.wa.gov/mapsdata/travel/hpms/functionalclass.htm)
  - Level and limits of limited access control.
  - Roadway section.
  - Interchange, grade separation, and intersection spacing.
  - Modal Priority determinations or Final Modal Accommodation Level and Land Use Context assessment (documented on the [Context and Modal Accommodation Report](#))
  - Travel markets and demographics, including special needs and vulnerable populations.
  - Existing and future planned pedestrian and bicycle trails or shared-use paths.
  - Existing and future planned transit service on or adjacent to the section.
  - Motor vehicle operational controls with emphasis on proposed fencing, the general concept of illumination, signing, and other traffic control devices, and an indication of how the operational controls will maintain or enhance connectivity for pedestrians and bicyclists.
  - Location of utilities and how they are affected.
  - Proposed plan for landscaping and beautification, including an artist's graphic rendition or design visualization.
4. Governmental responsibility, and comprehensive planning, land use, and community service relative to the new highway.
5. The disposition of frontage roads, city street and county road intersections, and excess right of way.
6. An appendix containing:
  - A glossary of engineering terms.
  - A traffic volume diagram(s) for all modes.
  - Pages showing diagrammatically or graphically the roadway section(s), operational controls, and rest areas (if rest areas are included in the project covered by the report) for all modes.
  - A vicinity map.
  - An access report plan and profiles for the project.
  - Basis of Design

The limited access report plan shows the effects of the proposed highway on the street and road system, transit service and pedestrian/bicyclist network by delineating the points of public access. (See the [Plans Preparation Manual](#) for a list of the minimum details to be shown on the plan and for a sample plan.)

7. Notifications and reviews. Upon receipt of the Phase 1 approval (see [Exhibit 510-1](#)) from the Director & State Design Engineer, Development Division, the region publishes the necessary copies, submits the limited access report to the county or city officials for review and approval, and meets with all involved local governmental agencies to discuss the report. Providing a form letter with a signature block for the local agency to use to indicate its approval of the limited access report can help expedite the review and approval process.

The region reviews any requests for modification and submits recommendations, with copies of any correspondence or related minutes, to the [HQ Access and Hearings Section](#).

### **530.02(4) Limited Access Hearing Plan**

The region prepares a limited access hearing plan to be used as an exhibit at the public hearing (see [Chapter 210](#) for hearings) and forwards it to the HQ Right of Way Plans Section for review. (See the [Plans Preparation Manual](#) for a list of data to be shown on the access hearing plan in addition to the access report plan data.)

When the plan review is completed by Headquarters, the access hearing plan is placed before the Director & State Design Engineer, Development Division, for approval of Phase 2 authority (see [Exhibit 510-1](#)).

### **530.02(5) Documentation**

Documentation for the establishment of limited access control is in [Chapter 210](#).

## **530.03 Full Control (Most Restrictive)**

### **530.03(1) Introduction**

Full control limited access highways allow access only through interchanges at selected public roads/streets, rest areas, viewpoints, or weigh stations, and by prohibiting at-grade crossings and approaches.

At times, on state highways (except interstate) where full access control has been established, staged acquisition of limited access may be used, subject to the approval of an access design analysis, with initial acquisition as partial or modified control and with ultimate acquisition of full control planned on the highway. When there is no feasible alternative within a reasonable cost, the decision to defer acquisition of limited access control must be documented and is subject to the approval of an access design analysis.

### **530.03(2) Application**

Terminate full control limited access sections at apparent logical points of design change. The following guidelines are to be used for the application of full control on limited access highways.

#### **530.03(2)(a) Interstate**

Full control is required on interstate highways.

### **530.03(2)(b) Principal Arterial**

Documentation assessing the evaluation of full control is required for principal arterial highways requiring four or more through traffic lanes within a 20-year design period unless approved for partial or modified control on existing highways.

### **530.03(2)(c) Minor Arterial and Collector**

Minor arterial and collector highways will not normally be considered for development to full control. However, short sections of full control to preserve the operational and safety performance of all modes may be appropriate in some situations.

## **530.03(3) Crossroads at Interchange Ramps**

At interchanges where ramps terminate with crossroads, limited access control will extend along crossroads, and in certain cases along local service or frontage roads (as shown in [Exhibits 530-1a through 530-1f](#)). This establishes the Interchange Functional Area, for the preservation of operational and safety performance of the interchange asset. For guidance on interchange spacing, see [Chapter 1360](#).

### **530.03(3)(a) Ramps**

At-grade intersections and approaches are prohibited within the full length of any interchange ramp. The ramp is considered to terminate at its intersection with the local road or street.

### **530.03(3)(b) Frontage Roads**

Direct access from the highway to a local service or frontage road is allowed only via the interchange crossroad (see [Exhibits 530-1a, 1b, 1c, and 1f](#)).

### **530.03(3)(c) Interchange Crossroads**

In both urban and rural areas, full control limited access must be established and then acquired along the crossroad at an interchange for a minimum distance of 300 feet. This distance is measured from the centerline of the intersection of the crossroad and ramp terminal unless noted otherwise in the conditions below. Control designs in all crossroad contexts should address and incorporate connectivity for shared-use paths, trails and sidewalks in and beyond the control area.

If a frontage road or local road is located at or within 350 feet of a ramp terminal, limited access will be established and then acquired up to the intersection, then along the crossroad and for an additional minimum distance of 130 feet in all directions from the centerline of the intersection of the crossroad and the frontage or local road, or measured from the outside edge of the outermost circulating roadway for roundabouts (see [Exhibits 530-1a, 1b, 1c, and 1f](#)).

For interchanges incorporating partial cloverleaf or buttonhook ramps (see [Exhibit 530-1b](#)), limited access is required for all portions of the crossroad and frontage roads between the ramp terminals and for a distance of 300 feet beyond the ramp terminals. If an at-grade intersection for a local road or street is served directly opposite the ramp terminals, limited access will be extended for a minimum of 300 feet along that leg of the intersection.



When the intersection in question is a roundabout, see [Exhibit 530-1c](#). This shows extension of full control along the crossroad to be 300 feet, measured from the center of the roundabout for an intersection with a ramp terminal.

[Exhibit 530-1d](#) shows the terminus of transition taper and that full control limited access is extended a minimum distance of 300 feet beyond the end of the farthest taper.

For a single point urban interchange (SPUI) with a right- or left-turn “ramp branch” separated by islands, limited access control is established and acquired for a minimum distance of 300 feet from the intersection of the centerline of the ramp branch with the centerline of the nearest directional roadway (see [Exhibit 530-1e](#).)

For a diverging diamond interchange, limited access control is established and acquired for a minimum distance of 300 feet from the end of the splitter island nose (see [Exhibit 530-1f](#)).

Not all interchange configurations match with the basic illustrations in this chapter. Consult with the [HQ Access and Hearings Section](#) for confirmation of limited access boundary requirements for non-traditional interchange configurations.

### **530.03(3)(d) Levels of Limited Access: Location of Approaches**

Provide full control for a minimum of 300 feet from the centerline of the ramp or terminus of a transition taper (see [Exhibits 530-1a through 530-1f](#)). The intent is to ensure approaches are far enough away from a frontage road intersection to provide efficient intersection operation.

If the economic considerations to implement full control for the entire 300 feet are excessive, then provide full control for at least the first 130 feet; partial or modified control may be provided for the remainder, for a total minimum distance of 300 feet of limited access. Full limited access should be extended as far as possible before any partial or modified access is implemented. Contact the HQ Access and Hearings Section when considering this option.

An approved access design analysis is required if the limited access control falls short of 300 feet or for any approach that has been allowed to remain within the first 130 feet.

### **530.03(4) Location of Utilities, Bus Stops, and Mailboxes**

#### **530.03(4)(a) Utilities**

Connecting utility lines are allowed along the outer right of way line between intermittent frontage roads. (See the [Utilities Accommodation Policy](#) regarding the location of and access to utilities.)

#### **530.03(4)(b) Bus Stops**

Common carrier or school bus stops are not allowed, except at:

- Railroad crossings (see [Chapter 1350](#)).
- Locations provided by the state on the interchanges (such as flyer stops).
- In exceptional cases, along the main roadway where pedestrian separation is available.

#### **530.03(4)(c) Mailboxes**

Mailboxes are not allowed on full control limited access highways. Mail delivery will be from frontage roads or other adjacent local roads.

### **530.03(5) Pedestrian and Bicyclist Crossings and Paths**

All pedestrian and bicyclist traffic is managed as follows:

- At-grade pedestrian and bicyclist crossings are allowed only at the at-grade intersections of ramp terminals.
- Pedestrian and bicyclist separations or other facilities are provided specifically for pedestrian and bicyclist use.
- Shared-use paths serving bicyclists, pedestrians, and other forms of active transportation. See [Chapter 1515](#).
- Bicyclists use the right-hand shoulders or other facilities as shown in [Chapter 1520](#), except where such use has been specifically prohibited. Information pertaining to such prohibition is available from the WSDOT website:  
<http://wsdot.wa.gov/bike/closed.htm>

Paths and trails, and access to and from, within a limited access highway are best planned and designed with the local agency's participation. Pedestrians and bicyclists are allowed, consistent with "Rules of the Road" ([RCW 46.61](#)), within the limits of full control limited access highways. Where existing or future planned paths are allowed they must be documented on the right of way and limited access plan. The plan shows the location of the existing or proposed path and where the path crosses limited access and provides movement notes (see [530.10\(1\)](#)). See [Chapter 1515](#) for shared-use path design guidance.

## **530.04 Partial Control**

### **530.04(1) Introduction**

Partial control may be established, when justified, on any highway except interstate. Partial control provides a considerable level of protection from motor vehicle traffic interference and protects the highway from future strip-type development while maintaining and improving appropriate active transportation network connections.

Upon acquisition of partial control limited access rights, the number, type, and use of access approaches of abutting property are frozen. The abutting property access rights and type of use are recorded on the property deed. The rights and use may not be altered by the abutting property owner, the local jurisdiction, or the region. This authority resides with the Director & State Design Engineer, Development Division (see [530.10](#)).

### **530.04(2) Application**

Partial control will not normally be used in urban areas, urbanizing area, suburban area, rural town centers or inside corporate limits on existing principal arterial highways where motor vehicle traffic volumes are less than 700 design hourly volume (DHV).

Terminate limited access sections at apparent logical points of design change.

#### **530.04(2)(a) Principal Arterial**

Partial control is considered when the estimated motor vehicle traffic volumes exceed 3,000 average daily traffic (ADT) within a 20-year design period on principal arterial highways requiring

two through motor vehicle traffic lanes. For multilane principal arterial highways, see [530.03\(2\)\(b\)](#).

#### **530.04(2)(b) Minor Arterial**

The minimum route length is: urban, 2 miles; rural, 5 miles; and combination urban and rural, 3 miles.

Partial control is required on:

- Rural minor arterial highways at both new and existing locations.
- Urban minor arterial highways at new locations requiring four or more through motor vehicle traffic lanes within a 20-year design period or requiring only two through motor vehicle traffic lanes where the estimated motor vehicle traffic volumes exceed 3,000 ADT within a 20-year design period.

Other rural minor arterial highways with only two motor vehicle lanes may be considered for partial control if any of the following conditions applies:

- The partial control can be acquired at a reasonable cost.
- The route connects two highways of a higher functional classification.
- The highway traverses publicly owned lands where partial control is desirable.

#### **530.04(2)(c) Collector: New Alignment**

Partial control is considered on collector highways in new locations requiring four or more through motor vehicle traffic lanes in a 20-year design period

#### **530.04(2)(d) Collector: Existing**

Existing collector highways will normally be considered for partial control limited access only when all of the following conditions apply:

- The highway serves an area that is not directly served by a higher functional classification of highway.
- Existing or planned development will result in motor vehicle traffic volumes significantly higher than what is required for partial control on minor arterials.
- Partial control can be established without a major impact on development of abutting properties within the constraints of established zoning at the time the partial control is proposed.

### **530.04(3) Interchanges and Intersections**

#### **530.04(3)(a) Interchanges**

Where an interchange occurs on a partial control limited access highway, full control applies at the interchange and interchange ramps. Refer to [530.03\(3\)](#) and see [Exhibits 530-1a, 1b, 1c, and 1f](#) for required minimum lengths of access control along the crossroad. For these and other interchange configurations not shown, consult with the HQ Access and Hearings Section for support developing limits of access control. (See [Chapter 1360](#) for guidance on interchange

spacing.) Where appropriate, address and incorporate connectivity for shared-use paths, trails and sidewalks in and beyond the control area.

### **530.04(3)(b) Intersections**

At an at-grade intersection on a partial control limited access highway, control will be established and acquired along the crossroad for a minimum distance of 300 feet from the centerline of the highway (see [Exhibit 530-2a](#)). Where appropriate, address and incorporate connectivity for shared-use paths, trails and sidewalks in and beyond the control area.

If another frontage or local road is located at or within 350 feet of the at-grade intersection, limited access will be established and then acquired along the crossroad, between the intersections, and:

- For an additional minimum distance of 130 feet in all directions from the centerline of the intersection of the frontage or local road (see [Exhibit 530-2a](#)).
- In the case of a roundabout, for an additional minimum distance of 300 feet along the crossroad, measured from the center of the roundabout (as shown in [Exhibit 530-2b](#)).

On multilane highways, measurements will be made from the centerline of the nearest directional roadway (see [Exhibit 530-2a](#)).

An approved access design analysis is required if the limited access control falls short of 300 feet or for any access that has been allowed to remain within the first 130 feet.

At-grade intersections with public roads are limited to the number allowed for the functional classification of highway involved, as follows:

#### **530.04(3)(b)(1) Principal Arterial**

If the ADT of the crossroad is less than 2,000, 1-mile spacing (minimum), centerline to centerline. If over 2,000 ADT within 20 years, plan for grade separation.

#### **530.04(3)(b)(2) Minor Arterial**

If the ADT of the crossroad is less than 2,000, ½-mile spacing (minimum), centerline to centerline. If over 2,000 ADT within 20 years, plan for grade separation.

#### **530.04(3)(b)(3) Collector**

Road (or street) plus property approaches, not more than six per side per mile.

With approval from the Director & State Design Engineer, Development Division, shorter intervals may be used where topography or other conditions (such as parcel sizes in some cases) restrict the design. Where intersecting roads are spaced farther apart than one per mile, median crossings may be considered for U-turns, in accordance with [Chapter 1310](#). Keep U-turns to a minimum, consistent with requirements for operation and maintenance of the highway.

To discourage movement in the wrong direction on multilane highways, locate private approaches 300 feet or more from an at-grade intersection. At a tee intersection, a private approach may be located directly opposite the intersection or a minimum of 300 feet away

from the intersection. Ensure a private approach directly opposite a tee intersection cannot be mistaken for a continuation or part of the public traveled way.

### **530.04(4) Access Approach**

Partial control is exercised to the level that, in addition to intersections with selected public roads, some crossings and private driveways may be allowed.

#### **530.04(4)(a) Approach Types**

Partial control limited access highways allow at-grade intersections with selected public roads, trails/shared-use paths, and private approaches using Type A, B, C, and F approaches. (See [Chapter 520](#) for the definitions of approach types.)

Type D, commercial approaches, are not allowed direct access to partial control limited access highways. Commercial access is allowed only by way of other public roads.

The type of approach provided for each parcel is based on current and potential land use and on an evaluation that assesses connectivity for all modes. (See [530.05\(4\)](#) for a list of evaluation criteria.)

#### **530.04(4)(b) Design Considerations**

The following considerations are used to determine the number and location of access approaches on partial control limited access highways.

1. Access approaches must be held to a minimum. The number is limited as follows:
  - Principal arterial: two per side per mile
  - Minor arterial: four per side per mile
  - Collector: six per side per mile, including at-grade intersections
2. Approaches in excess of the number listed above may be allowed as staged construction (until full buildout is complete) if approved by the Director & State Design Engineer, Development Division.
3. Approaches are not allowed for parcels that have reasonable access to other public roads unless a parcel has extensive highway frontage.
4. Relocate or close approaches in areas where sight limitations create undue hazards.
5. Allow only one approach for each parcel, except for very large ownerships, or where terrain features do not allow the property to be served by a single approach. This includes contiguous parcels under a single ownership.
6. Where possible, locate a single approach to serve two or more parcels.
7. The approved design is to provide for future development of frontage roads that will eliminate an excessive number of approaches.

## **530.04(5) Location of Utilities, Bus Stops, and Mailboxes**

### **530.04(5)(a) Utilities**

Connecting utility lines are allowed along the outer right of way line between intermittent frontage roads. (See the [Utilities Accommodation Policy](#) regarding the location of and access to utilities.)

### **530.04(5)(b) Bus Stops**

Bus stops for both common carriers and school buses are not allowed on either two-lane or four-lane highways except:

- At railroad crossings (see [Chapter 1350](#)).
- At locations of intersections with necessary pullouts to be constructed by the state.
- Where shoulder widening has been provided for mail delivery service.
- For a designated school bus loading zone on or adjacent to the traveled lane, that has been approved by WSDOT.

Buses are not allowed to stop in the traveled lanes blocking at-grade intersections or private approaches to load or unload passengers.

School bus loading zones on partial control limited access highways must be posted with school bus loading zone signs, in accordance with the latest edition of the [Manual on Uniform Traffic Control Devices](#) (MUTCD).

### **530.04(5)(c) Mailboxes**

Locate mailboxes on frontage roads or at intersections, with the following exceptions for properties that are served by Type A or B approaches:

- Locate mailboxes on a four-lane highway only on the side of the highway on which the deeded approach is provided.
- Locate mailboxes on a two-lane highway on the side of the highway that is on the right in the direction of the mail delivery.

Wherever mailboxes are allowed on a partial control limited access highway, provide mailbox turnouts to allow mail delivery vehicles to stop clear of the through traffic lanes.

(See [Chapter 1600](#) for additional information concerning mailbox locations and turnouts.)

## **530.04(6) Pedestrian and Bicyclist Crossings and Paths**

Pedestrian and bicyclist crossings are allowed on partial control limited access highways when they are grade-separated.

At-grade pedestrian and bicyclist crossings are allowed:

- Only at intersections where an at-grade crossing is provided in accordance with [Chapter 1510](#).
- On two-lane highways at mailbox locations.

- On two-lane highways not less than 100 feet from a school bus loading zone (pullout) adjacent to the traveled lane, if school district and WSDOT personnel determine that the bus stopping in the traveled lane is hazardous.
- On two-lane highways where the school bus is stopped on the traveled lane to load or unload passengers and the required sign and signal lights are displayed.

On partial control limited access highways, pedestrian and bicyclist traffic is allowed, consistent with “Rules of the Road” ([RCW 46.61](#)), except where unusual safety conditions support prohibition. Information pertaining to such prohibitions is available from the WSDOT website: <http://wsdot.wa.gov/bike/closed.htm>

Paths and trails, and access to and from, within a partial control limited access highway are best planned and designed with the local agency’s participation. Where existing and future planned paths are allowed, they must be documented on the right of way and limited access plan. The plan shows the location of the existing or proposed path and where the path crosses limited access, and it provides movement notes (see [530.10\(1\)](#)), with the intention of maintaining and improving active transportation connectivity.

## **530.05 Modified Control (Least Restrictive)**

### **530.05(1) Introduction**

Modified control is intended to prevent further deterioration in the safety and motor vehicle operational characteristics of existing highways by limiting the number and location of access points.

Upon acquisition of modified control limited access, the number, type, and use of access approaches of abutting property are frozen. The abutting property access rights and type of use are recorded on the property deed. The rights and use may not be altered by the abutting property owner, the local jurisdiction, or the region. This authority resides with the Director & State Design Engineer, Development Division (see [530.10](#)).

### **530.05(2) Application**

In general, modified control is applied where some level of control is desired, but existing and potential commercial development precludes the implementation of full or partial control.

#### **530.05(2)(a) Existing Highways**

Modified control may be established and acquired on existing highways other than main line interstate. Priority is given to highway segments where one or more of the following conditions applies:

- Commercial development potential is high, but most of the adjoining property remains undeveloped.
- There is a reasonable expectation that the adjoining property will be redeveloped to a more intensive land use, resulting in greater motor vehicle traffic congestion and increased presence of people walking, bicycling, and/or accessing transit service.
- At interchange areas if full or partial access cannot be provided as described in [530.03\(3\)\(d\)](#).

### 530.05(2)(b) Modified Control Evaluation

Selection of highways on which modified control may be applied is based on an evaluation that includes the following contextual factors for all modes:

- The current form of managed access control
- Traffic volumes
- Level of service, or other selected mobility performance metric
- Selected safety performance
- Functional class
- Route continuity
- Mix of residential, destination and employment densities
- Operational considerations related to achieving the selected motor vehicle target speed
- Operational considerations related to transportation efficiency for people utilizing active transportation
- Local land use planning
- Current and potential land use
- Predicted growth rate
- Economic analysis

### 530.05(2)(c) Exceptions

Where modified control is to be established, developed commercial areas may be excepted from control when all or most of the abutting property has been developed to the extent that few, if any, additional commercial approaches will be needed with full development of the area. Contact the [HQ Access and Hearings Section](#) when considering this option. If this exception is within the limits of access control, an approved access design analysis is required.

### 530.05(3) Intersections

At an intersection on a modified control limited access highway, access control will be established and acquired along the crossroad for a minimum distance of 130 feet:

- Measured from the centerline of a two-lane highway (see [Exhibit 530-3b](#)).
- Measured from the centerline of the nearest directional roadway of a four-lane highway (see [Exhibit 530-3b](#)).
- Measured from the outside edge of the circulating roadway of a roundabout (see [Exhibit 530-3a](#)).

Approaches are allowed within this area only when there is no reasonable alternative. An approved access design analysis is required for any access that has been allowed to remain within the first 130 feet. Where appropriate, address and incorporate connectivity for shared-use paths, trails and sidewalks in and beyond the control area.



### **530.05(4) Access Approach**

The number and location of approaches on a highway with modified control must be carefully planned and monitored to provide a safe and efficient highway compatible with present and potential land use.

#### **530.05(4)(a) Approach Types**

Modified control limited access highways allow at-grade intersections with selected public roads, shared-use paths/trails, and with private approaches using Type A, B, C, and D approaches. (See [Chapter 520](#) for definitions of the approach types.)

The type of approach provided for each parcel is based on present and potential land use and an evaluation of the following criteria:

- Local comprehensive plans, zoning, and land use ordinances
- Property covenants and agreements
- City or county ordinances
- The highest and best use of the property
- The highest and best use of adjoining lands
- A change in use by merger of adjoining ownerships
- All other factors bearing upon proper land use of the parcel

#### **530.05(4)(b) Design Considerations**

The following items are used to determine the number and location of approaches:

1. Parcels that have access to another public road or street are not normally allowed direct access to the highway.
2. Meets sight distance criteria (see Chapter 1340).
3. Hold the number of access approaches to a minimum. Access approaches are limited to one approach for each parcel of land or where adjoining parcels are under one contiguous ownership.
4. Encourage joint use of access approaches where similar use of land and topography allows.
5. Additional approaches may be allowed for future development consistent with local zoning. Once limited access has been acquired, this will require a value determination process (see [530.10](#)).

Close existing access approaches not meeting the above.

### **530.05(5) Location of Utilities, Bus Stops, and Mailboxes**

#### **530.05(5)(a) Utilities**

Connecting utility lines are allowed along the outer right of way line between intermittent frontage roads. (See the Utilities Accommodation Policy regarding location of and access to utilities.)

### **530.05(5)(b) Bus Stops**

Bus stops are allowed as follows:

- In rural areas, bus stops are subject to the same restrictions as in [530.04\(5\)](#) and (6).
- In urban areas, bus stops for both commercial carriers and school buses are allowed. (See [Chapter 1430](#) for transit stop considerations and pullout designs.)

### **530.05(5)(c) Mailboxes**

Locate mailboxes adjacent to or opposite all authorized approaches as follows:

- On a four-lane highway only on the side of the highway on which the deeded approach is provided.
- On a two-lane highway on the side of the highway that is on the right in the direction of the mail delivery.

Where mailboxes are allowed, a mailbox turnout is recommended to allow mail delivery vehicles to stop clear of the through traffic lanes. (See [Chapter 1600](#) for additional information concerning mailbox locations and turnouts.)

## ***530.05(6) Pedestrian and Bicyclist Crossings and Paths Pedestrian and Bicycle Traffic and Paths***

Pedestrian and bicyclist crossings are allowed as follows.

Pedestrians and bicyclists are allowed, consistent with “Rules of the Road” ([RCW 46.61](#)), on modified control limited access highways except where unusual safety considerations support prohibition. Information pertaining to such prohibitions is available from the WSDOT website: <http://wsdot.wa.gov/bike/closed.htm>

Paths and trails, and access to and from, within a modified control limited access highway are best planned and designed with the local agency’s participation. Where existing or future planned paths are allowed, they must be documented in the right of way and limited access plan. The plan shows the location of the existing or proposed path and where the path crosses limited access, and it provides movement notes (see [530.10\(1\)](#)) with the intention of maintaining and improving active transportation connectivity.

## **530.06 Access Approaches**

### ***530.06(1) General***

Access approaches may be allowed on limited access highways, consistent with the requirements outlined in [530.03](#), [530.04](#), and [530.05](#).

For additional information pertaining to approaches, refer to [Chapters 1320](#) (roundabouts), [1340](#) (approach design templates), and [510](#) (right of way), and the [Plans Preparation Manual](#).

The widths for the approach types are negotiated, and only the negotiated widths are shown on the right of way and limited access plan. (See [Chapter 520](#) for definitions of the approach types.)

## 530.07 Frontage Roads

Local agency approval is required for any planned frontage roads, county roads, city streets, cul-de-sacs, or shared-use paths/trails. The local agency must also agree in writing to accept and maintain the new section as a county road or city street.

### 530.07(1) General

Frontage roads are provided in conjunction with limited access highways to:

- Limit access to the main line.
- Provide access to abutting land ownerships.
- Restore the continuity of the local street or roadway system and active transportation network.

Refer to [Chapter 1210](#) for frontage road general policy and [Chapter 300](#) for required documentation.

By agreement under which the state is reimbursed for all costs involved, frontage roads that are not the responsibility of the state may be built by the state upon the request of a local political subdivision, a private agency, or an individual.

### 530.07(2) County Road and City Street

To connect roads or streets or walk/bike connections that have been closed off by the highway, short sections of county roads, city streets, or shared-use paths/trails that are not adjacent to the highway may be constructed if they will serve the same purpose as, and cost less than, a frontage road.

### 530.07(3) Cul-de-sacs

For a frontage road or local street bearing substantial traffic that is terminated or closed at one end, provide a cul-de-sac or other street or roadway consistent with local policy or practice, that is sufficient to allow vehicles to turn around without encroachment on private property.

Consider and address continued connectivity and provision of alternate routes for pedestrians and bicyclists.

## 530.08 Turnbacks

When WSDOT transfers jurisdiction of operating right of way to a city, town, or county, a turnback agreement is required. (See the [Agreements Manual](#) for turnback procedures.)

Locate the turnback limits at points of logical termination. This will allow WSDOT to retain an adequate amount of right of way for maintenance of the highway and for other operational functions.

In areas where limited access rights have been acquired from the abutting property owners, the limited access rights will continue to be required for highway purposes; therefore, the limited access rights will not be included as part of a turnback agreement.

When a signalized intersection is in the area of a turnback, locate the turnback limit outside the detector loops if WSDOT is continuing the ownership, operation, and maintenance of the signal

system. For a roundabout, locate the turnback limit at the back of the raised approach splitter island if WSDOT is continuing the ownership, operation, and maintenance of the roundabout.

## **530.09 Adjacent Railroads**

### **530.09(1) General**

A limited access highway and a railroad are considered adjacent when they have a common right of way border with no other property separating them. The allowed approaches apply only to adjacent railroad property that is directly used for current railroad operation.

### **530.09(2) Requirements**

It is in the public's interest to provide access to the railroad right of way, from limited access highways, for maintenance of the railroad and the utilities located on the railroad right of way where other access is not feasible. This applies to both new highways and to existing highways where limited access has been acquired.

Direct access is allowed where local roads are infrequent or there are few highway-railroad crossings from which trail-type access for maintenance purposes is feasible, and where unique topography or other unusual conditions lead to its use.

To provide direct approaches for access to railroad right of way, all of the following conditions must be met:

- A maximum of one approach is allowed for every 2 miles of highway.
- The approach must not adversely affect the design, construction, stability, traffic safety, or operation of the highway.
- Except where the railroad is located in the median area, the approach is to be accomplished in a legal manner by right turns only, to and from the roadway nearest the railroad. Median crossing is not allowed.
- The approach is secured by a locked gate under arrangements satisfactory to the department. (See the Definitions section in [Chapter 520](#) for Approach Type C, and [Chapter 550](#).)
- The parking of any vehicles or railroad equipment is prohibited within limited access highway right of way.
- A special emergency maintenance permit must be obtained for periods of intensive railroad maintenance.
- The approach must be closed if the railroad operation ceases.
- Approaches are limited to use by the railroad company unless specific provisions for other use are shown on the right of way and limited access plan and included in the right of way negotiations.

### **530.09(3) Restrictions**

Direct access to a railroad from the highway is considered unnecessary and is not allowed where:

- There are local roads adjacent to or crossing the railroad.
- A trail-type road can be provided by the railroad between crossroads.
- The limited access highway is paralleled by a frontage road adjacent to the railroad.
- No highway previously existed adjacent to the railroad.

## 530.10 Access Breaks and Inner Corridor Access

This section addresses three topics:

- [530.10\(1\)](#) applies to access breaks and inner corridor access of limited access rights of way on full, partial and modified highways.
- [530.10\(2\)](#) provides specific detail on changes for private approaches.
- [530.10\(3\)](#) provides specific guidance on changes for public approaches.

### 530.10(1) General

When non-highway purpose activities are proposed that involve either crossing limited access boundaries or entering into roadside areas from within limited access facilities, a formal request shall be approved prior to the activity or use. The request will be either an access break or an inner corridor access.

**An access break** is needed when the limited access boundary is to be crossed. This refers to any point from inside or outside the state limited access right of way limited access hachures that crosses over, under, or physically through the plane of the limited access.

**An inner corridor access** is needed when entry into roadside areas inside of the limited access corridor is to be made from within the limited access boundary. Inner corridor access may be from a mainline, a ramp, or from a local road or street that is also within limited access.

Evaluate the following factors concerning a potential access break or inner corridor access:

- Crash potential for all modes, including how crash types and contributing factors and how operational considerations related to the access break would change
- Level of access control (full, partial, or modified)
- Existing and planned land use changes
- Functional classification
- Land use and zoning
- Environment impacts/mitigation
- Determination from a [Corridor Sketch](#), [Basis of Design](#) and/or [CMAR](#)

Regional staff or Program staff work with the requesting party to compile and submit access break and inner corridor access requests to the HQ Access and Hearings Section. The request package will contain the completed access request checklist and all supporting documents and will be submitted electronically using instructions located on the Access and Hearings Section website: [www.wsdot.wa.gov/design/accessandhearings](http://www.wsdot.wa.gov/design/accessandhearings)

### 530.10(1)(a) Approvals

Access breaks (either temporary or permanent) and inner corridor access for all limited access state highways require approval prior to implementation.

For permanent access breaks or inner corridor access approvals involving existing property rights, the right of way and limited access plan must be revised and deeds may need to be rewritten.

On non-interstate limited access routes, WSDOT HQ approves access breaks and inner corridor access.

On interstate routes, [23 CFR 710.403](#) requires prior approval from FHWA. Note that any changes proposed on Interstate limited access facilities must include environmental documentation in the request, as required by FHWA. Contact the [HQ Access and Hearings Section](#) for assistance.

### 530.10(2) Changes for Private Access Approaches (Modified/Partial Control Only)

Private accesses are allowed within modified control and sometimes allowed within partial control ([WAC 468-58-010](#)).

#### 530.10(2)(a) Requirements

Examples of access modifications requested by abutting property owners include additional road approaches, changes in the allowed use, or additional users of existing road approaches.

Plan revisions that provide for additional access to abutting properties after WSDOT has purchased the access rights are discouraged. However, these revisions may be considered if the following can be established:

- There are no other reasonable alternatives.
- The efficiency and safety of the highway will not be adversely impacted.
- The existing situation causes extreme hardship on the owner(s).
- The revision is consistent with the limited access highway requirements.

#### 530.10(2)(b) Procedures

The region initiates a preliminary engineering review of the requested modification to or break in limited access and contacts the [HQ Access and Hearings Section](#) to determine whether conceptual approval can be granted for the request. If conceptual approval can be granted, then:

- The region initiates an engineering review of the requested modification.
- The region prepares and submits to the HQ Right of Way Plans Section a preliminary right of way and limited access plan revision, together with a recommendation for Headquarters approval. When federal-aid funds are involved in any phase of the project, the proposed modification will be sent to FHWA for review and approval.
- The recommendation will include an item-by-item analysis of the factors listed in [530.10\(1\)](#) and [530.10\(2\)\(a\)](#).

### 530.10(2)(c) Valuation Determination

Upon preliminary approval, region Real Estate Services prepares an appraisal for the value of the access change using a before and after appraisal.

- The appraisal follows the requirements set forth in the [Right of Way Manual](#).
- The appraisal package is sent to [HQ Real Estate Services](#) for review and approval.
- If federal-aid funds were involved in purchasing access control, HQ Real Estate Services will send a copy of the appraisal package to FHWA for review and approval.

### 530.10(2)(d) Final Processing

- Region Real Estate Services informs the requester of the approved appraised value for the change.
- If the requester is still interested, the region prepares a “Surplus Disposal Package” for HQ Real Estate Services’ review and approval.
- At the same time, the preliminary right of way and limited access plan revision previously transmitted is processed for approval.
- After the department collects the payment from the requester, the region issues a permit for the construction, if required.
- If an existing approach is being surrendered, region Real Estate Services obtains a conveyance from the property owner.
- HQ Real Estate Services prepares and processes a deed granting the change to the access rights.

## 530.10(3) Changes for Public At-Grade Intersections (Modified/Partial Control Only)

### 530.10(3)(a) Requirements

- Public at-grade intersections on partial or modified control limited access highways serve local arterials that form part of the local transportation network for all modes.
- Requests for new intersections on limited access highways must be made by or through the local governmental agency to WSDOT. The region will forward this request, including the data referenced in [530.10\(1\)](#) and [530.10\(2\)\(a\)](#) to the [HQ Access and Hearings Section](#).
- WSDOT must comply with the hearing, or waiver, process as outlined in [Chapter 210](#) and discussed in [Section 530.02\(2\)a](#). The access acquisition and conveyance must be completed prior to beginning construction of the new intersection. The new intersection is to meet WSDOT design and spacing requirements, unless otherwise approved through design analysis document.

### 530.10(3)(b) Procedures

- The region evaluates the request for modification and contacts the HQ Access and Hearings Section for conceptual approval.

- The region submits an intersection plan for approval (see [Chapter 1310](#)) and a right of way and limited access plan revision request (see the [Plans Preparation Manual](#)). This plan includes the limited access design requirements for all modes along the proposed public at-grade intersection.
- The Director & State Design Engineer, Development Division, approves the intersection plan.
- The Assistant Secretary, Regions and Mega Programs/Chief Engineer (or designee), approves the access revision.
- The region submits the construction agreement to the Director & State Design Engineer, Development Division (see the [Agreements Manual](#)).
- The Assistant Secretary, Regions and Mega Programs/Chief Engineer (or designee), approves the construction agreement.

### **530.10(3)(c) Valuation Determination**

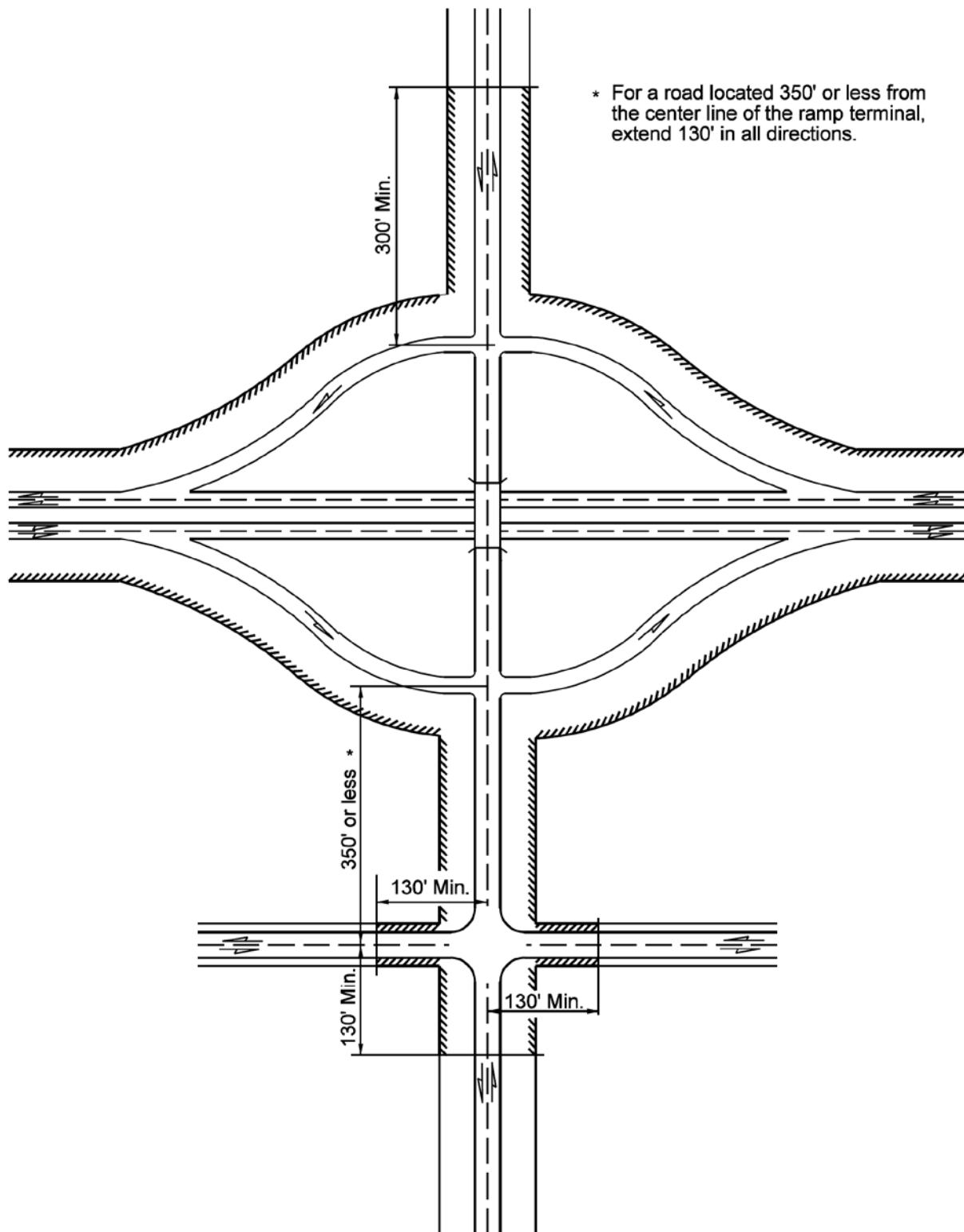
- When a requested public at-grade intersection will serve a local arterial that immediately connects to the local transportation network, compensation will not be required.
- When a requested public at-grade intersection will serve only a limited area, does not immediately connect to the local transportation network, or is primarily for the benefit of a limited number of developers, compensation for the access change will be addressed in the plan revision request. In these situations, compensation is appropriate and a value will be determined as outlined in [530.10\(2\)\(c\)](#).

## **530.11 Documentation**

Refer to Chapters [210](#), [300](#), and [550](#) for design documentation requirements.

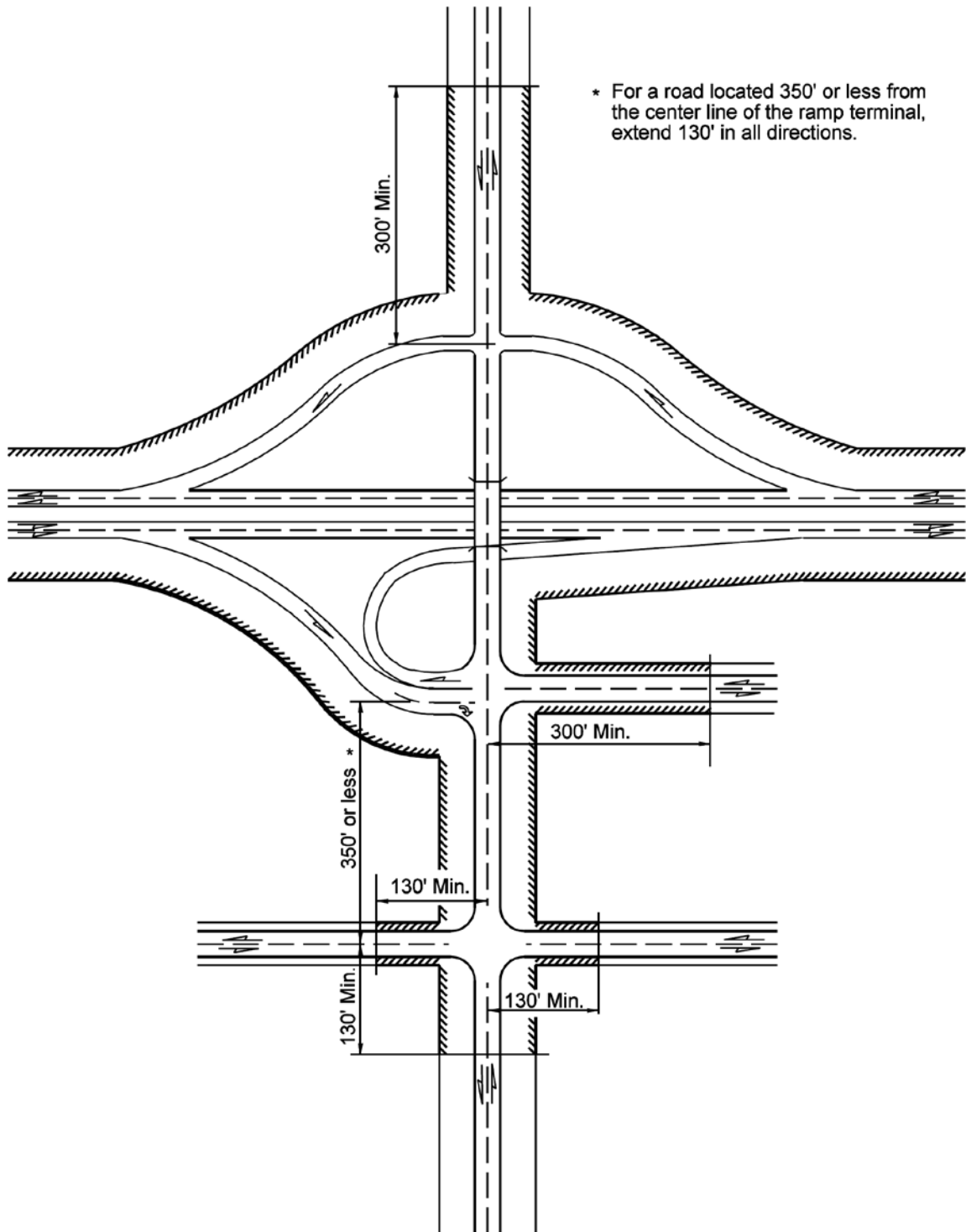


Exhibit 530-1a Full Access Control Limits: Interchange



\* For a road located 350' or less from the center line of the ramp terminal, extend 130' in all directions.

Exhibit 530-1b Full Access Control Limits: Interchange



\* For a road located 350' or less from the center line of the ramp terminal, extend 130' in all directions.

Exhibit 530-1c Full Access Control Limits: Interchange with Roundabouts

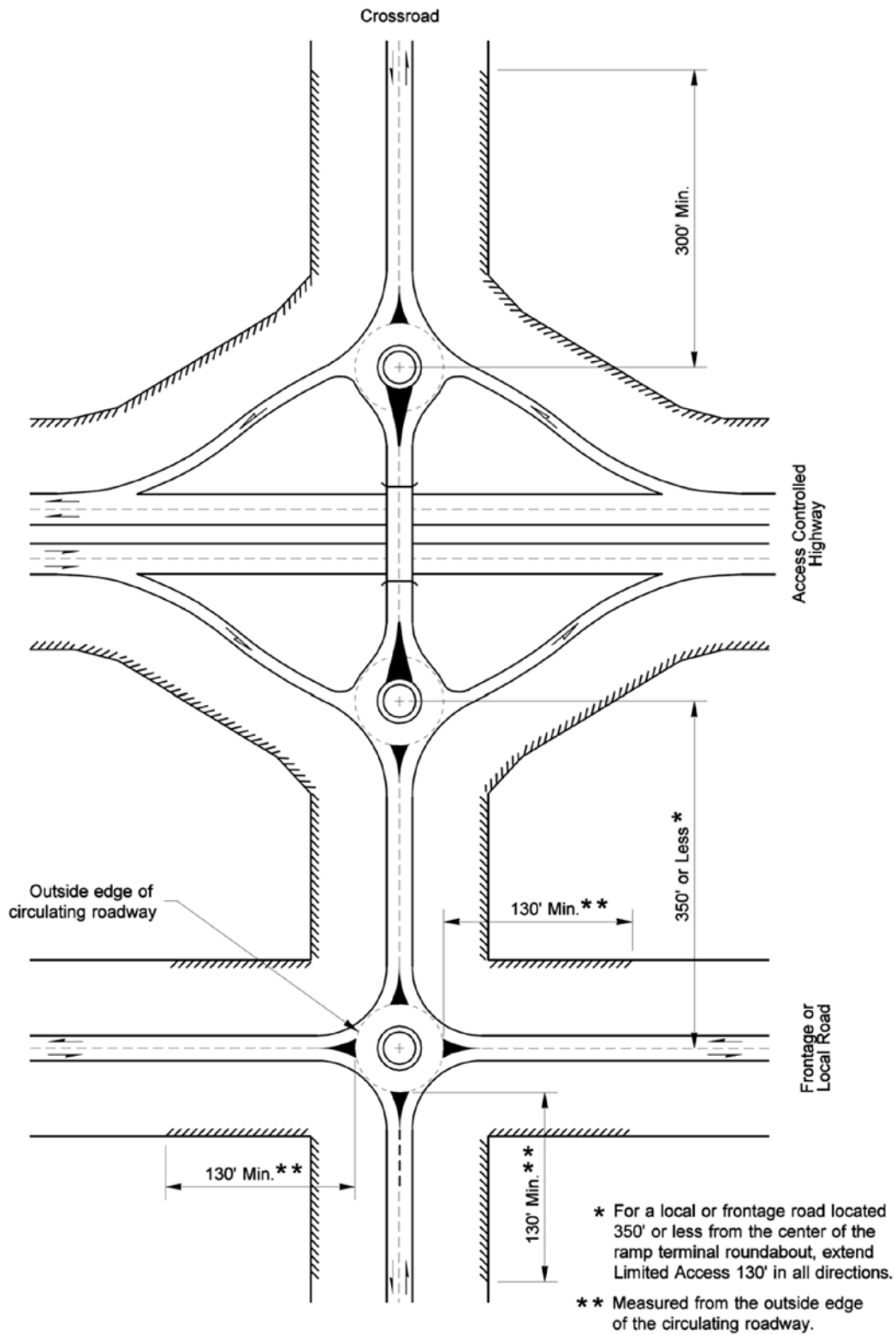


Exhibit 530-1d Full Access Control Limits: Ramp Terminal with Transition Taper

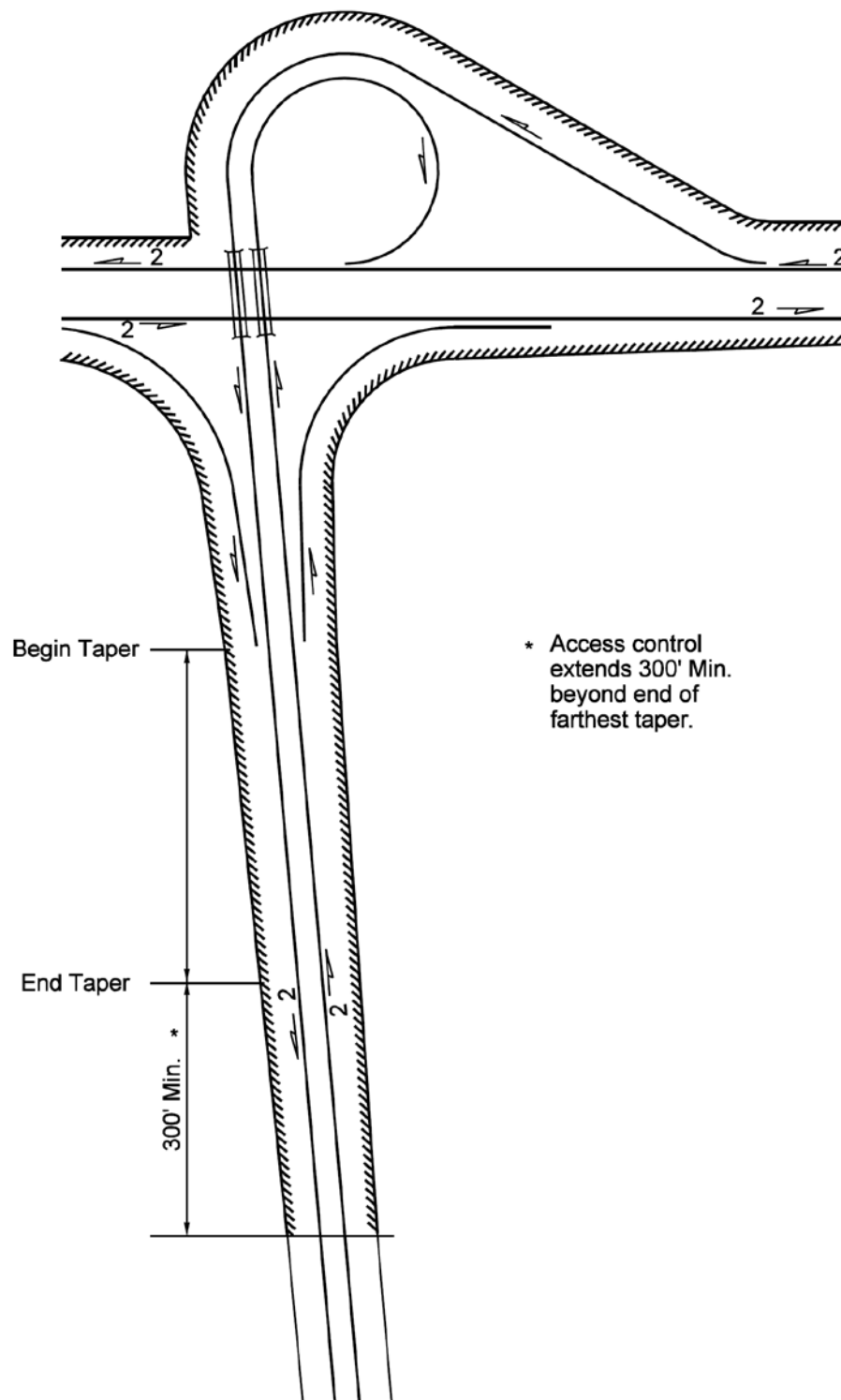


Exhibit 530-1e Full Access Control Limits: Single Point Urban Interchange

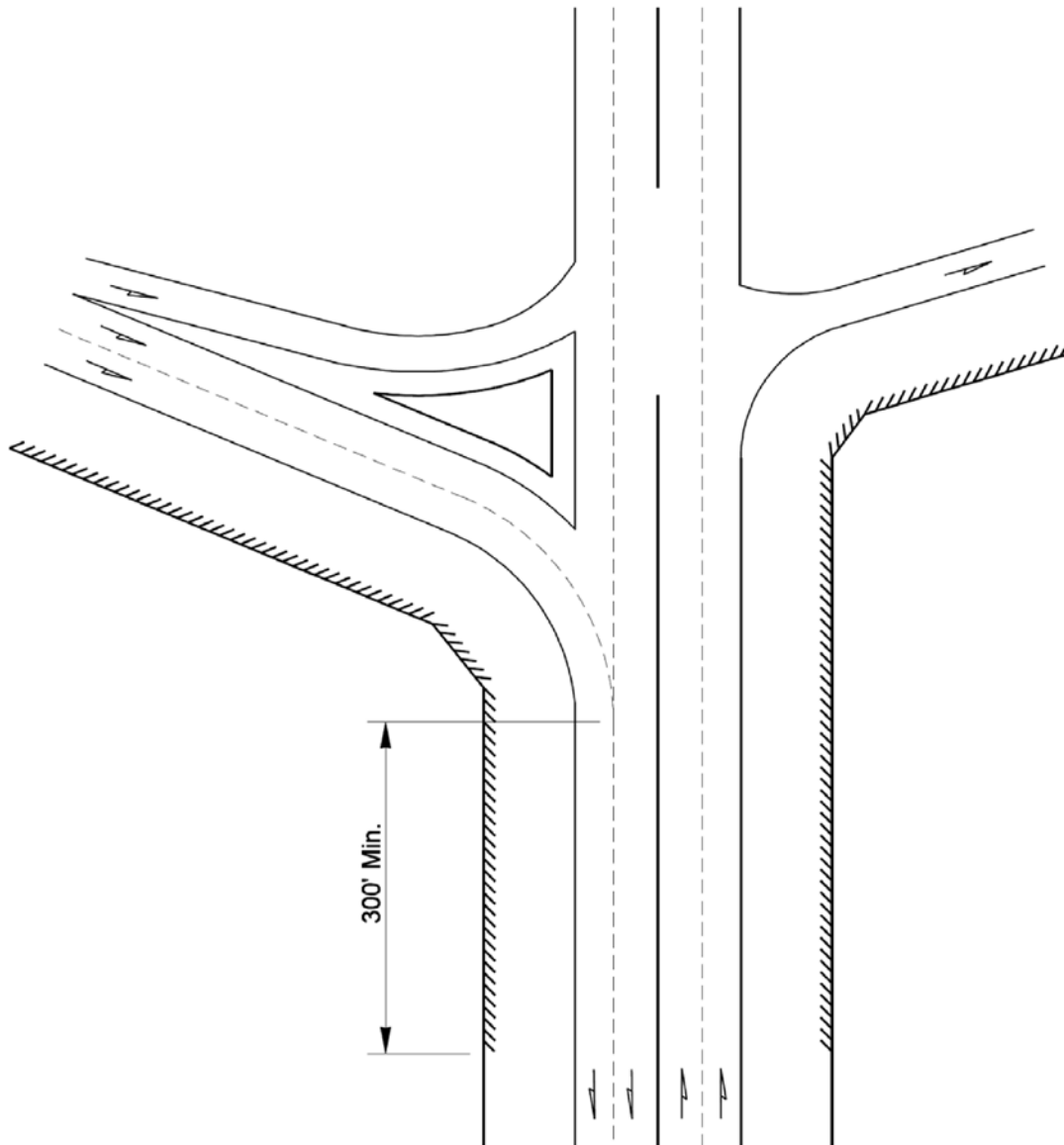
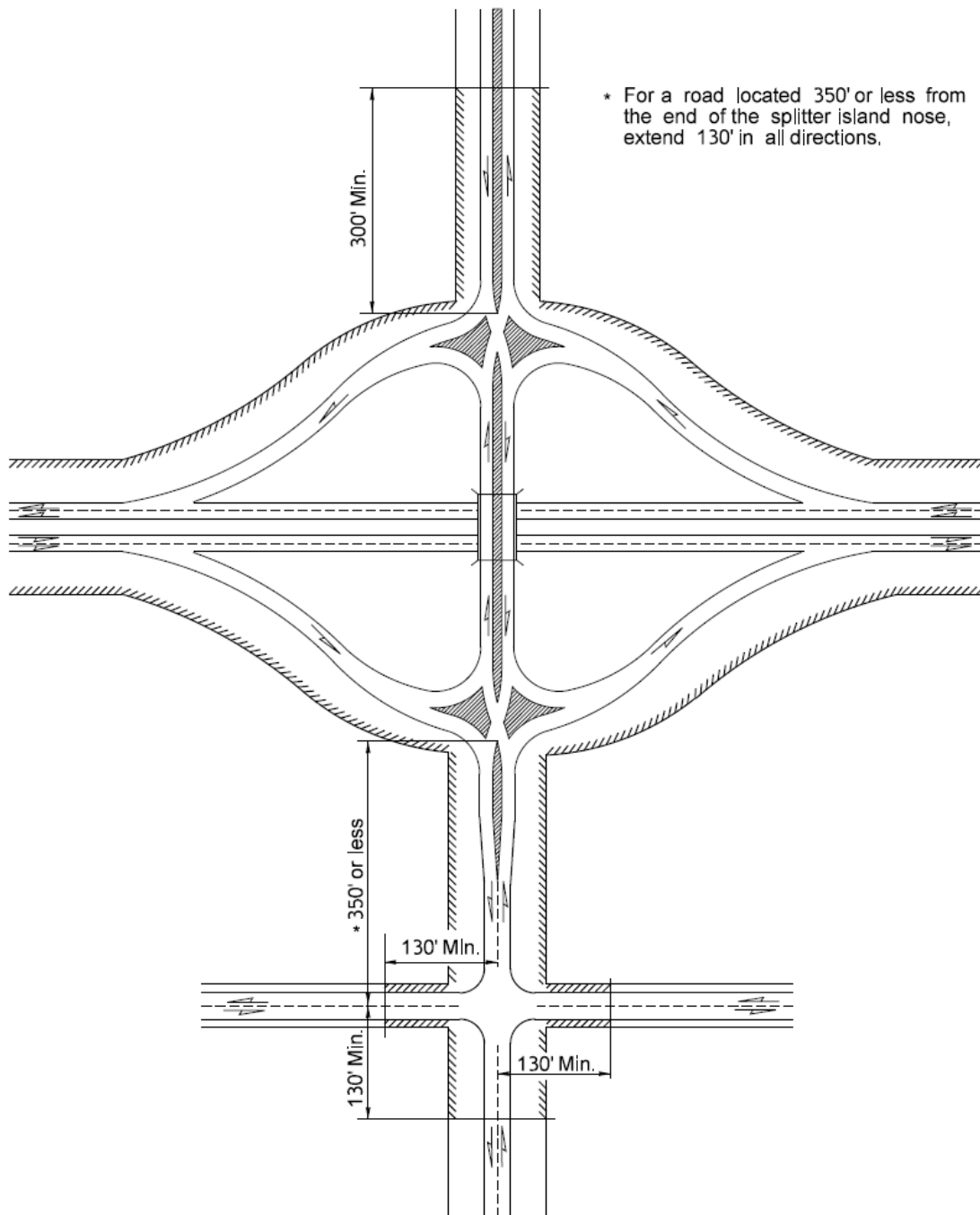


Exhibit 530-1f Full Access Control Limits: Diverging Diamond Interchange



## Exhibit 530-2a Partial Access Control Limits: At-Grade Intersections

- \* For a road located 350' or less from the center line of the nearest directional roadway, extend access control 130' in all directions.

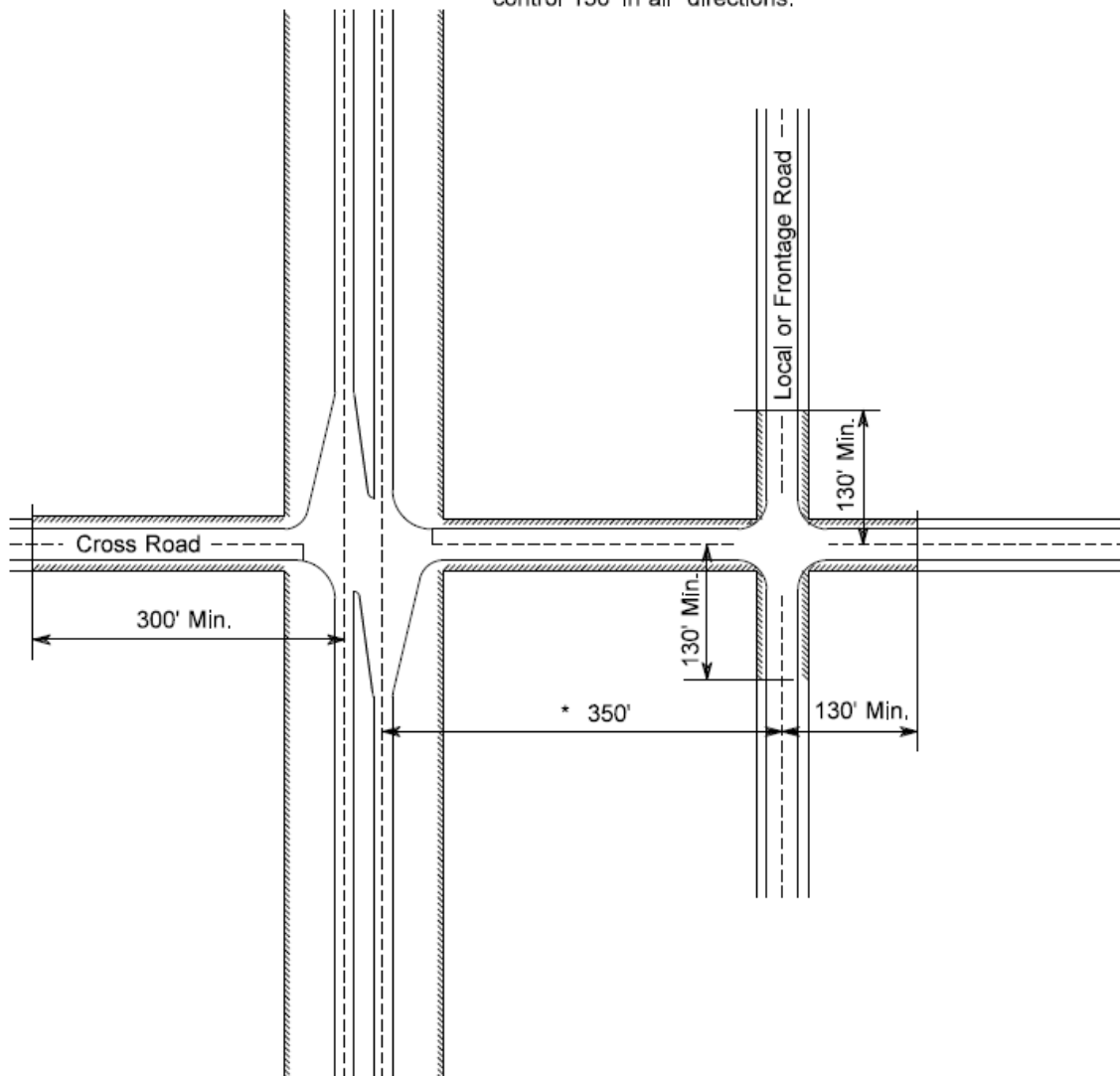
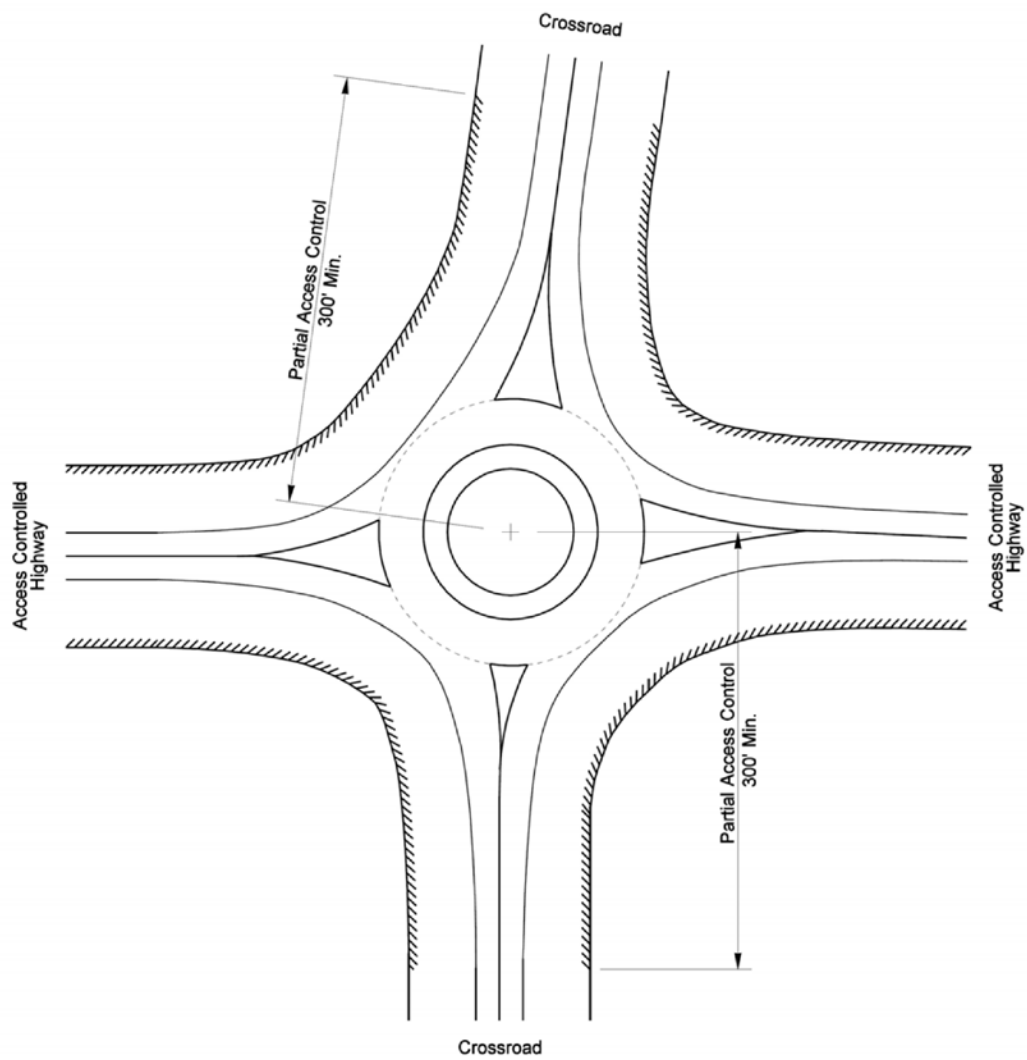


Exhibit 530-2b Partial Access Control Limits: Roundabout Intersections

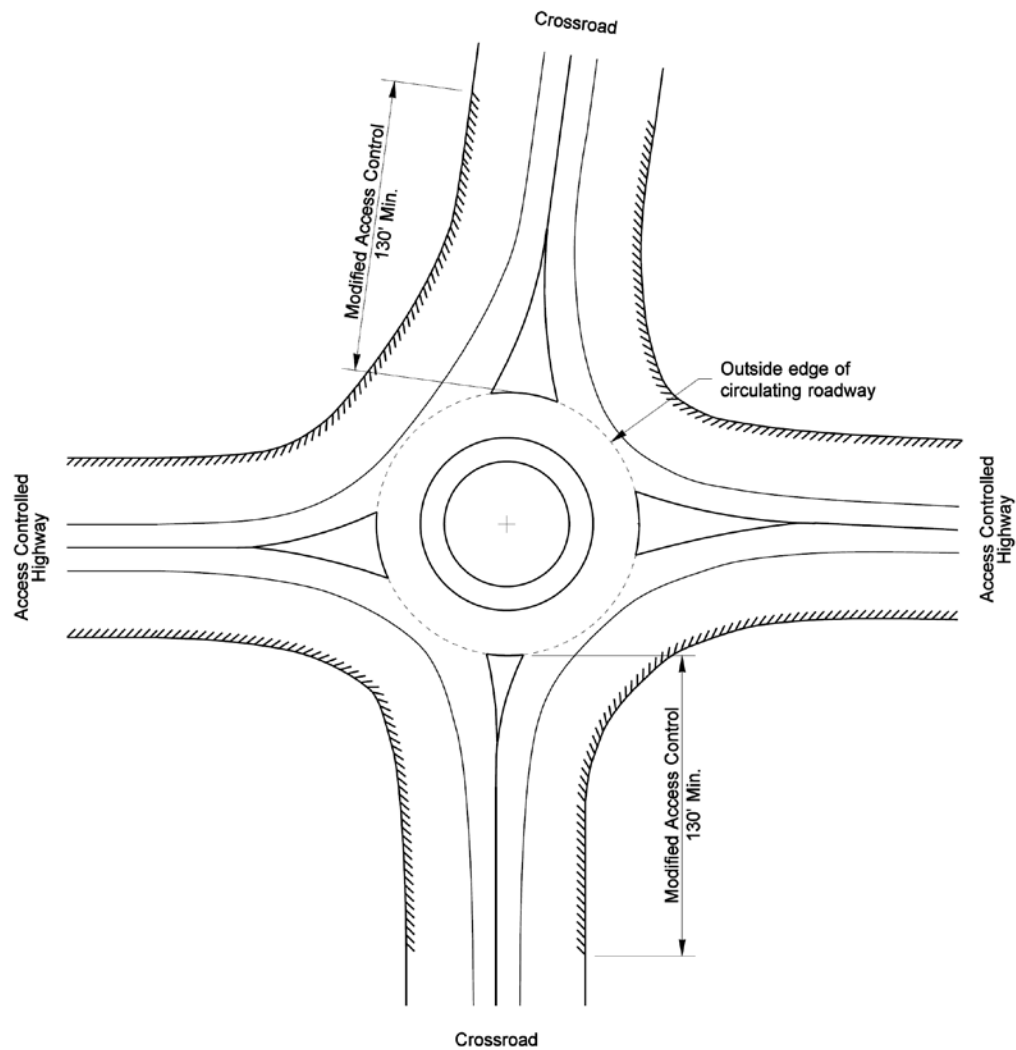


**Note:**

Partial access control is measured from the center of the roundabout.



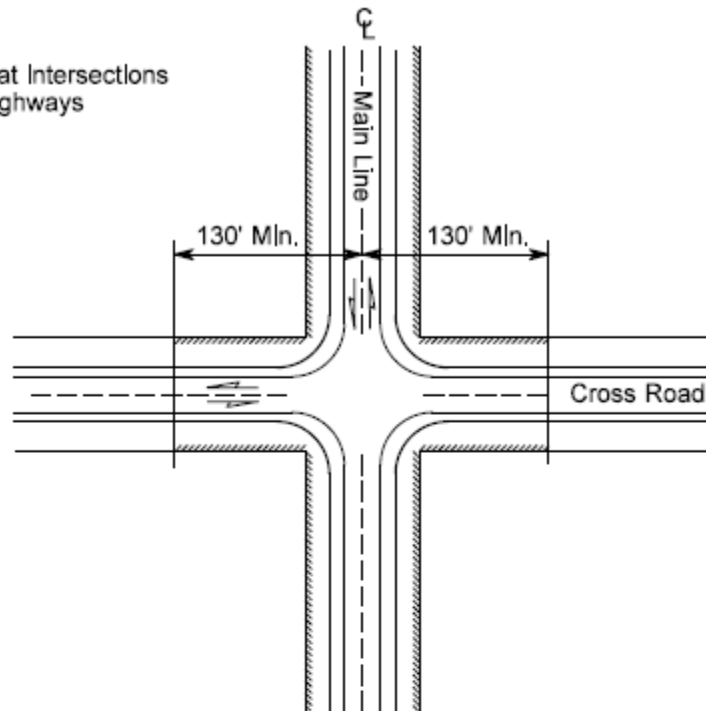
## Exhibit 530-3a Modified Access Control Limits: Roundabout Intersections

**Note:**

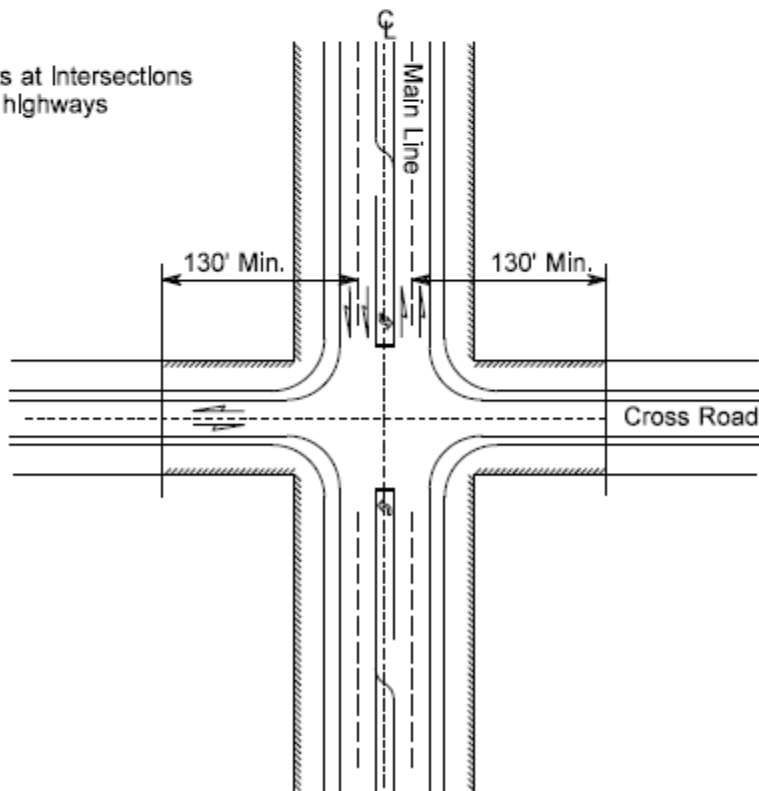
Modified access control is measured from the outside edge of the circulating roadway.

Exhibit 530-3b Modified Access Control Limits: Intersections

Access control limits at Intersections  
modified control highways  
two-lane



Access control limits at Intersections  
modified control highways  
multilane



- 550.01 [Overview](#)
- 550.02 [Freeway Access Policy](#)
- 550.03 [Access Revision Analysis Process](#)
- 550.04 [Support Teams](#)
- 550.05 [Non-Access Feasibility Study](#)
- 550.06 [Access Revision Report Process](#)
- 550.07 [Documentation](#)
- 550.08 [References](#)

## 550.01 Overview

It is in the national and state interest to preserve and enhance the Interstate and non-Interstate freeway system in Washington providing an appropriate level of service in terms of safety and mobility performance for the movement of people and goods. Full control of access along the freeway mainline and ramps, along with control of access on the local roadway network within the interchange functional area, is critical to providing such service. Therefore, decisions to approve new or revised interchange access points on Washington's freeways depend on consistent application of procedures, analysis, and supporting documentation.

In May 2017, the Federal Highway Administration (FHWA) significantly revised its access policy. In the memorandum transmitting the new policy to the FHWA Division Administrators, FHWA states:

“The FHWA has identified several areas where the current Policy may be streamlined to eliminate duplication with other project reviews. The new Policy will now focus on the technical feasibility of any proposed change in access in support of FHWA's determination of safety, operational, and engineering acceptability. Consideration of the social, economic, and environmental impacts and planning considerations will be addressed through the National Environmental Policy Act (NEPA) review of the project. This change will eliminate the potential for duplicative analysis of those issues in the State DOT's Interstate Access report and the NEPA documentation. The change will allow State DOTs to submit only a single technical report describing the types and results of technical analyses conducted to show that the change in access will not have significant negative impact on the safety and operations of the Interstate System.”

The federal policy change points to a clear link between the NEPA and access revision processes. The NEPA process will account for the social, economic, and environmental impacts and a technical report herein called the Access Revision Report (ARR) will account for the safety and operational impacts.

## 550.02 Freeway Access Policy

Federal law requires FHWA approval of all access revisions to the Interstate system. Both FHWA and WSDOT policy require the formal submission of a request to either add, revise, or abandon access to freeways. FHWA and WSDOT freeway access policies also require proposed access changes be consistent with the vision, goals, and long-range transportation plans of a metropolitan area, region, and state.

**Interstate freeways:** New or revised access to Interstate freeways requires collaboration with and approval from FHWA. WSDOT and local partners need to include FHWA from the beginning of the planning process throughout the development of the proposal. WSDOT is the only entity recognized by FHWA Washington Division that is allowed to submit requests for Interstate access revisions for review and approval.

**Non-Interstate freeways:** New or revised access to non-Interstate freeways requires engagement with and approval from WSDOT.

For consistency in analysis and reporting, the policy to revise freeway access is the same for both Interstate and non-Interstate freeways. The only major difference is in the approving authorities, described above. [Exhibit 550-4](#) helps clarify what is considered an access revision and presents approval authorities for both Interstate and non-Interstate access revisions.

The contents of this chapter provides the requirements and expectations to fulfill this policy.

**Note:** For breaks in freeway limited access that do not involve new, revised, or abandoned traffic interchanges, follow procedures given in [Chapter 530](#) Limited Access Control. Examples include locked gates, pedestrian structures, and access to fire hydrants within the full control limited access. Contact the HQ Design Office, [Access and Hearings Section](#) for support.

### 550.03 Access Revision Process

The access revision process begins when an entity considers the potential of revising access to a freeway (Interstate or non-Interstate). There are two distinct steps in the access revision process: a non-access feasibility study and an Access Revision Report. Both steps focus on safety performance and operations for all modes. The feasibility study is the beginning of the process and the conclusion of the feasibility study defines the purpose and verifies the need for a potential access revision. If the feasibility study concludes that an access revision is not necessary, the process is finished. If the feasibility study concludes that an access revision is necessary, then an Access Revision Report is written and the conclusion of the ARR determines the preferred access revision alternative. These two steps are detailed in the subsequent sections of this chapter. [Exhibit 550-1](#) presents a flow chart detailing the Non-Access Feasibility Study process; [Exhibit 550-2](#) provides the ARR process.

For the process to be successful, there needs to be a clear link to the planning and environmental processes. The planning linkage should be addressed at the beginning of the process to make sure the access revision decision aligns with local, regional, and state planning efforts. This planning linkage is discussed in more detail in [Section 550.05\(2\)\(a\)](#). The environmental linkage exists throughout the process as the Federal policy promotes a more direct link between this access revision process and the environmental process. This chapter includes callouts to the environmental process at key points to highlight this linkage and to help align the processes and reduce duplication between the two processes.

The access revision and practical design processes correlate through the use of the [Context and Modal Accommodation Report](#) (CMAR) and the [Basis of Design](#) (BOD). The CMAR can help determine modal priority and accommodation on non-freeway segments, such as the crossroad proposed for the freeway access connection. The CMAR may be completed during the feasibility study. The BOD can help document baseline and contextual needs and set the direction for a future project. Sections 1 through 3 of the BOD (Project Need, Context, and Design Controls) may be completed at the end of the Non-Access Feasibility Study. Sections 4 and 5 (Alternatives

Analysis and Design Element Selection) of the BOD should be completed in conjunction with the ARR. The BOD completed with the ARR may be considered the scoping BOD.

Use the Design Support website to download the CMAR, the CMAR learners Guide, the Basis of Design and Alternatives Comparison Table. <http://www.wsdot.wa.gov/Design/Support.htm>

### **550.03(1) Scalability**

The access revision process varies greatly due to the complexities of the transportation system and context environment planned for the horizon year (see [Chapter 1103](#)). Not all access revision cases require a full-scale ARR. [Exhibit 550-4](#) reflects the access revision documentation levels for select project types. For variation from [Exhibit 550-4](#) or clarification on scalability, discuss with the Assistant State Design Engineer (ASDE). Document the scalability in the method and assumptions documents.

### **550.03(2) Environmental Documentation Linkage**

Implement Planning and Environmental Linkage (PEL) principles during the access revision process to minimize rework in the environmental review/NEPA stage of the project. Using the PEL approach is most valuable where an Environmental Assessment (EA) or Environmental Impact Statement (EIS) is required. [Chapter 200](#) of the Environmental Manual details this beneficial link between planning and environmental processes.

The new FHWA policy states clearly that the environmental documentation and access revision processes be linked and aligned to reduce duplication of effort. Throughout this access revision analysis process, key points correlate with the environmental process. For best results, make sure the environmental staff is fully engaged and involved in the process. Region Environmental staff will help determine the best NEPA / SEPA compliance strategy. The team, including FHWA, determines the type of environmental document required during the feasibility phase of access review. Since FHWA approval of Interstate access revisions entails a federal action, National Environmental Policy Act (NEPA) requirements apply to Interstate access reviews. If NEPA does not apply to a freeway access revision, environmental documentation through the State Environmental Policy Act (SEPA) does apply. In either case, the team, comprised of experts and agents from WSDOT and FHWA, is authorized to determine the type of environmental documentation required.

---

*Best Practice: Engage WSDOT Environmental experts to determine NEPA / SEPA strategy.*

---

If the team determines the project can be documented as a Categorical Exclusion/ Exemption (CE), involvement from environmental staff at key decision points will help ensure the project is appropriately scoped and environmental considerations are integrated into the ARR as appropriate. For a CE, information from the Non-Access Feasibility Study can be useful, but is typically much more detailed than the information required for the CE checklist.

## 550.04 Support Teams

### 550.04(1) Executive Support Team

Establish an executive support team before beginning the feasibility study. The executive support team is active throughout the access revision process. Their primary duty is to interpret policy and set direction for their representatives involved in the technical support team. The representatives will be signees on the deliverables that are required throughout this chapter. The executive support team meets to monitor the progress of the deliverables and prepares records of meeting minutes and decisions.

Due to the scalability of the process, the executive support team can vary with each access revision case but will typically have a core of the following individuals:

- FHWA Safety and Geometric Design Engineer
- Region Representatives (Assistant Regional Administrator, Traffic Engineer, Local Programs Engineer, Environmental Manager, and/or Planning Manager)
- Assistant State Design Engineer
- HQ Traffic
- Local agency representatives (city, county, port, transit and/or tribal government)

### 550.04(2) Technical Support Team

The technical support team conducts a majority of the detailed analyses required throughout the access revision process. This team meets regularly to ensure deliverables and project details are coordinated across disciplines. A subgroup of the technical team may also conduct separate meetings to coordinate specific details. The technical team delivers results and conclusions of their work back to the executive support team for review and approval. The technical group records and tracks meeting minutes and action items.

Due to the scalability of the process, the technical support team can vary with each access revision case. Work with the executive support team to make sure the right personnel are on the team. The team members may include representation from the following groups:

- Planning organization (Metropolitan Planning Organization (MPO) and/or Regional Transportation Planning Organization (RTPO))
- FHWA (Area Engineer, Environmental Program Manager, and/or ITS Engineer)
- WSDOT Region (planning, design, environmental, maintenance, and/or traffic)
- WSDOT HQ [Multimodal Development & Delivery](#)
- Local agency specialist (planning, developer services, public works, and/or engineering)
- Project proponents specialists (developer and/or consultant)
- Multimodal specialist (transit, bike, and/or pedestrian)
- Other identified stakeholders/partners

## 550.05 Non-Access Feasibility Study Process

The goal of this first step in the access revision process is to look at the non-access transportation network to determine if improvements can be made that address performance gaps for all modes. **Non-access improvements are solutions that do not impact the gore points to/from the mainline of the freeway.** Examples are changes to the local street network, travel demand management, traffic operations enhancements, crossroads, ramp meters, minor geometric ramp modifications, transit, and minor ramp terminal modifications.

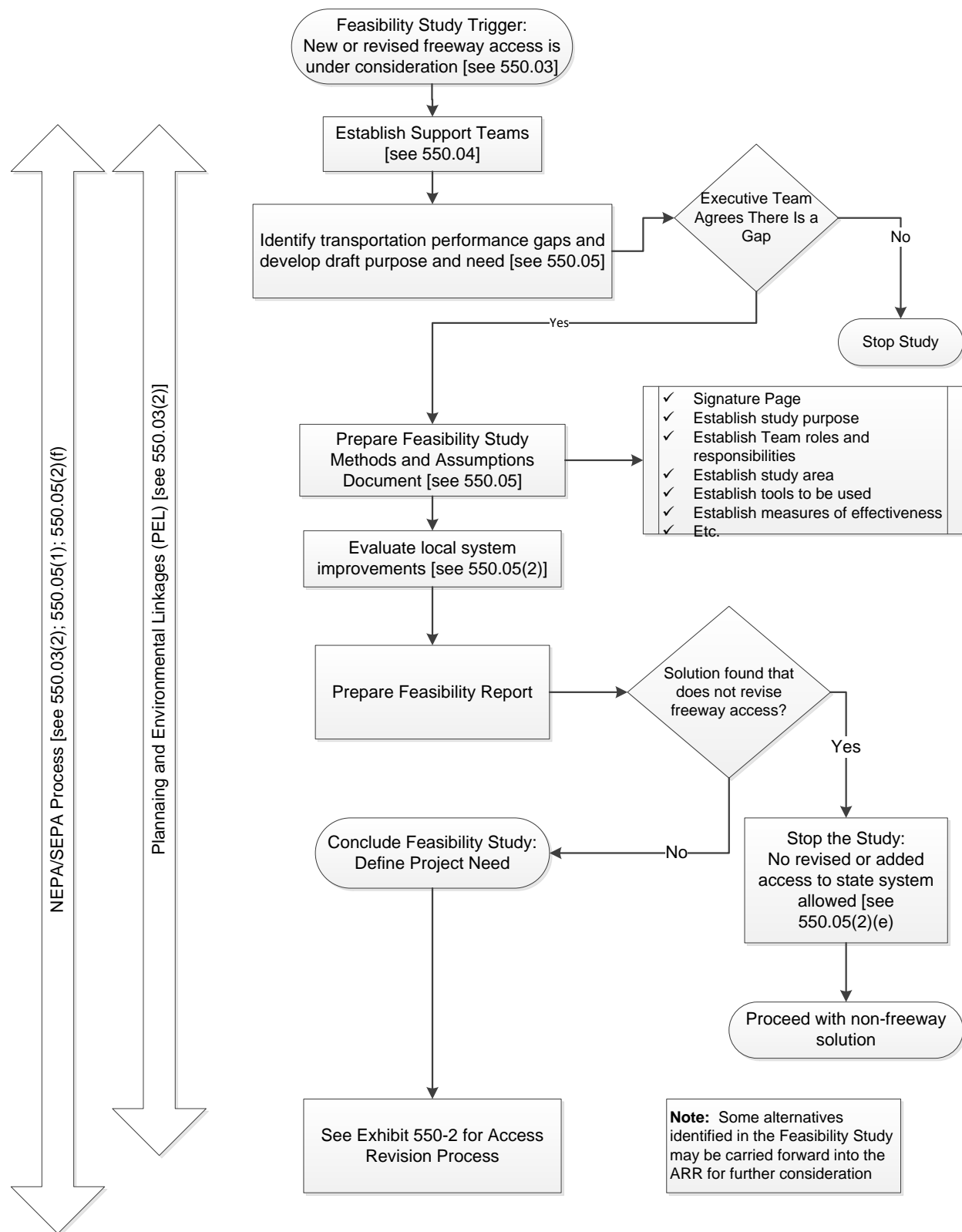
The Non-Access Feasibility Study is a multistep process and begins (see [Exhibit 550-1](#)) with assembling an executive support team. The WSDOT Region assembles the executive support team. The executive support team convenes and the local, regional, tribal, or state entity that is the proponent of the access revision presents the performance gaps that represent the probable baseline needs for an access revision. If the executive support team agrees there is a probable performance gap that needs further study, then the technical support team is formed. The technical support team develops the draft purpose and need and the process of conducting a non-access feasibility study begins and a method and assumptions (M&A) document is prepared.

---

*Performance Gap – The difference between the measured and targeted performance unit for a performance metric. See 1100 Series Chapters.*

---

Exhibit 550-1 Non-Access Feasibility Study Process





Linking to the state and local planning representatives is essential. It is possible that a local planning study has been conducted that meets the requirements of the non-access feasibility study. If this is the case, the executive support team can make the determination that the planning study is sufficient and move on to the ARR. It is necessary to also coordinate with the region's environmental representative to help ensure the local planning study is sufficient in developing the purpose and need necessary for the environmental process.

---

*Planning Linkage – The best projects consider and complement local, regional, and state transportation plans for all modes.*

---

### **550.05(1) Non-Access Feasibility Study Methods and Assumptions Document**

The next step in a Non-Access Feasibility Study is to create a methods and assumptions (M&A) document that establishes the methods followed while the study is being conducted and the assumptions made during the study. Cover the following points in the M&A document:

- Team Participants
  - Executive team members, roles, and responsibilities
  - Technical team members, roles, and responsibilities
- Scalability (if applicable, see [Section 550.03\(1\)](#) and [Exhibit 550-4](#))
- Planning Linkage
  - Pertinent planning documents
  - Prior community engagement
- Environmental Linkage
  - Probable environmental documentation: EIS, EA, or CE
  - NEPA/SEPA compliance strategy
- Community Engagement
  - See [Community Engagement Plan](#)
- Alternatives Selection
  - Process for determining non-access reasonable alternatives including alternative development and screening
- Traffic Operational Analysis Scope and Scale
  - Determine the study area for operational analysis. For efficiency and uniformity of data, it may be beneficial to assume a freeway access revision will be necessary when determining the study area. Discuss the study area in detail, reach agreement on its scope and scale, and record in the M&A document. Typical analysis study areas include:
    - Particularly in urbanized areas, at least the first adjacent existing or proposed interchange on either side of where an access revision is being considered and the entire freeway components within this area.
    - The crossroads to at least the first major intersection on either side of where the access revision is being considered. The local street network should be extended as necessary to fully evaluate the impacts of the proposed change in access.

- Incorporate connections to the transit network inside the study area as modifications to the transit service may impact travel demand.
  - Incorporate regional trails/pathways inside the study area as improving multimodal connectivity may impact travel demand.
- Study period: AM/PM Peak, midday, weekends
- Study years: Current, opening, design/horizon
- Methodology: Highway Capacity Manual or other tool
- Multimodal priorities and accommodation
  - Transit operations and considerations: Transit must be given consideration in locations where freeways are at capacity in the peak hours.
  - Bicyclist networks connectivity, needs, considerations.
  - Pedestrian access and network connectivity, needs, considerations.
- Tools: Software versions and default software settings
- Traffic forecasting methodology:
- Measures of effectiveness
- Safety Performance Analysis Scope and Scale (See [Chapter 321](#))
  - Study area
  - Study period
  - Study years: Current, opening, design/horizon
  - Methodology
  - Tools
  - Measures of effectiveness
- Identify and Record Assumptions
  - Base Improvements – Transportation projects that will be built by developers, local agencies, and the state and what year they will be built.
  - Items that are uncertain and may have an impact on the analysis. For example funding, tolling, context changes, modal shift, or travel demand management.
- Change Management
  - How will your study address changes in assumptions, scope, or deliverables?

The above list is not all-encompassing nor is everything in the list covered in every study. The technical support team refines the above list as necessary and submits the outline of the feasibility study to the executive support team for concurrence.

The Non-Access Feasibility Study M&A document contains a signature page for concurrence by the executive support team. A template for the M&A document is here:

<http://www.wsdot.wa.gov/design/accessandhearings>

The Non-Access Feasibility Study may begin upon concurrence of the M&A document.

### **550.05(2) Non-Access Feasibility Study**

Conduct and document the non-access feasibility study following the assumptions and guidance set forth in the M&A document. This determines whether non-access improvements can address the performance gaps agreed upon by the executive support team. The Non-Access Feasibility Study contains the following items:

- Signature Page

- Project Background
- Vicinity Map
  - Study Area
- Planning Linkage (see Chapter 550.05(2)(a))
  - Multimodal Needs
- Traffic Volumes (see Chapter 550.05(2)(b))
- Traffic Operational Analysis (see Chapter 550.05(2)(c))
- Safety Performance Analysis (see Chapter 550.05(2)(d))
- Reasonable Non-Access Alternatives (see Chapter 550.05(2)(e))
- Conclusion (see Chapter 550.05(2)(f))
  - Purpose and Need for Access Revision

Non-Access Feasibility Study is compiled and reviewed first by the technical support team prior to being sent to the executive support team for signature. If the process does not go into the ARR phase, then send a final copy of the Non-Access Feasibility Report to your ASDE for filing. If the process continues into the ARR phase, then attach the Non-Access Feasibility Report to the ARR as an appendix.

### 550.05(2)(a) Planning Linkage

It is essential to create the linkage to the transportation planning processes and outputs by the WSDOT and other agencies in the non-access feasibility study. Any transportation improvement considered in the access revision process should align with these planning processes. Describe how the improvements are consistent with local land use plans, and local, regional, and state transportation plans including possible future interchanges, bicyclist/pedestrian networks, transit service, and possible development.

While the need for freeway access is motor vehicle based, it is also important to address the needs of all modes that will access and use the local networks and freeway crossroad(s). An important aspect of the planning linkage is to address multimodal connectivity on the crossroad. While interchange crossroads may provide vehicle access to and from the freeway mainline, they also provide critical multimodal connectivity between land uses on either side of the freeway. Consult comprehensive land use and transportation plans for multimodal elements. Document multimodal needs, priority, and accommodation in the Non-Access Feasibility Study.

---

*Consistent and purposeful planning linkages between agency partners helps the process.*

---

A non-access feasibility study may be performed in conjunction with another planning process. When a non-access feasibility study is performed in conjunction with another planning process, then that process must address the requirements for a non-access feasibility study in addition to requirements of other planning processes. Include WSDOT Planning and local agency staff (land use and transportation planning specialties) in the technical support team to determine if this linkage is possible or beneficial.

If another planning process or study appears to meet the requirements of the Non-Access Feasibility Study, have the technical support team review it and determine if it is applicable. If the technical team finds the process or study meets the requirements of the feasibility study, then present it to the executive support team and request an exemption from the feasibility

study process. Clearly document this exemption and receive written approval from the members of the executive support team.

### **550.05(2)(b) Traffic Volumes**

Traffic volumes for the existing, opening, design, and horizon year are determined and reported in the feasibility study. It is important to consider pedestrian, bicyclist, and transit volumes where applicable. The existing year is the year the traffic data is collected. Consult [Chapter 1103](#) for definitions and details of opening, design, and horizon years.

The data for the future years may come from a regional transportation model or linear projections unique to the study. Exponential growth projections are not recommended.

Regional transportation models may also be used for the opening and design year volumes. Transportation models are commonly maintained by a Metropolitan Planning Organization. These models predict traffic volumes by dividing the area into zones, populating these zones with the appropriate type of land use, and predicting travel demand on the road network based upon the trip demand and travel time between destinations. The process to develop these models is extensive; therefore, the models are not continuously updated. Opening/design years that do not correlate with the years of the regional transportation model may be adjusted by a linear growth rate to the opening/design year of the traffic study. The technical support team determines how to best use an available model. Document the model used, how the model was calibrated and validated.

Traffic models used for the ARR process should incorporate transit, bicyclists, and pedestrians. If the model does not have the ability to incorporate these other modes, investigate the viability of modifying link and intra-zone trips with the technical support team to reflect the multimodal trips. Consider how changing access to these other modes may impact travel demand within and through the study area.

If linear projections are used, be careful to not base projection on a valley or peak in historic traffic volumes. Record any assumptions applied to linear projections in the feasibility study.

### **550.05(2)(c) Operational Analysis**

Conduct the operational analysis over the study area, using the tools and methodology in accordance with the M&A document. Conduct the operational analysis on the opening and design year. The technical support team determines if it is necessary to have existing year analysis or if the no-build at opening year is sufficient. For these years:

- Conduct the Existing operational analysis over the study area (if required by the technical support team)
  - No change in the existing roadway network.
  - Use the existing traffic volumes and calibrate to existing conditions to determine if the analysis reflects existing conditions and the model is validated.
- Conduct Base Improvements operational analysis over the study area
  - The existing roadway network with the addition of local or non-access transportation projects and services that are funded for construction/delivery or have a high likelihood of being constructed/delivered, as identified as base network improvements in the M&A document. Incorporate base network improvements into the analysis.

- o The result of this base improvements operational analysis is a list of the locations where the transportation system has potential performance gaps. Compare this list of locations to the performance gaps identified in the beginning of the access revision process. The analysis helps clarify whether or not performance gaps exist. Identify these gaps in the report. These identified gaps will be where the technical support team focuses in the operational analysis done for the reasonable non-access alternatives. This leads to identification of performance targets by mode.
- Conduct the Build operational analysis over the study area
  - o Incorporate the base improvements as the starting point, then evaluate reasonable non-access alternatives as discussed in 550.05(2)(e)
  - o The build operational analysis assess whether the non-access alternatives address the identified performance gaps.

### 550.05(2)(d) Safety Analysis

Conduct a safety analysis per Chapter 321.04 and Section 8.1 of the *Safety Analysis Guide*. In this section of the feasibility study, discuss the safety performance of the existing transportation network. For the non-access Feasibility Study, the safety analysis needs to focus on the non-access network; safety analysis of the freeway mainline is not required.

### 550.05(2)(e) Reasonable Non-Access Alternatives

The Non-Access Feasibility Study must look at reasonable alternatives that can address the performance gaps noted in the operational analysis and/or safety performance analysis. The determination of reasonable alternatives follows the process as noted in Chapter 400.07(1)4 of the WSDOT *Environmental Manual*. Each reasonable alternative must consider the change in safety performance per the *Safety Analysis Guide*.

The goal of the alternatives is to identify non-access improvements and performance targets that address operation gaps and safety performance characteristics for all modes. Alternatives should first consider non-access, operational and/or demand management improvements. Coordinate these improvements with local and state planning staff. The technical support team initiates alternatives for consideration and presents them to the executive support team for approval. Include alternatives comprised of varying types such as intersection solutions, corridor solutions, land use modifications, transit improvements, mode shift, travel demand management or other systematic network-based Practical Solutions approaches. Use the measures of effectiveness discussed in the methods and assumptions document to compare alternatives.

---

*Performance target – an outcome or desired state intended for a part of the system.*

*See Chapter 1101.*

---

Provide a list of non-access improvements needed to address the performance gaps. If an improvement will be within the state's jurisdiction, then complete a scoping Basis of Design for this improvement and include as an appendix to the feasibility study. If the non-access improvements can address the performance gaps within the criteria defined in the M&A, then state such in this section and conclude the access revision process.

If the non-access improvements do not completely address the performance gaps, but do show value, then they should be carried forward into the access revision analysis for further inclusion in the project.

#### **550.05(2)(f) Non-Access Conclusion**

If the non-access improvements can address the performance gaps within the criteria defined in the M&A, then state such in this section and conclude the access revision process.

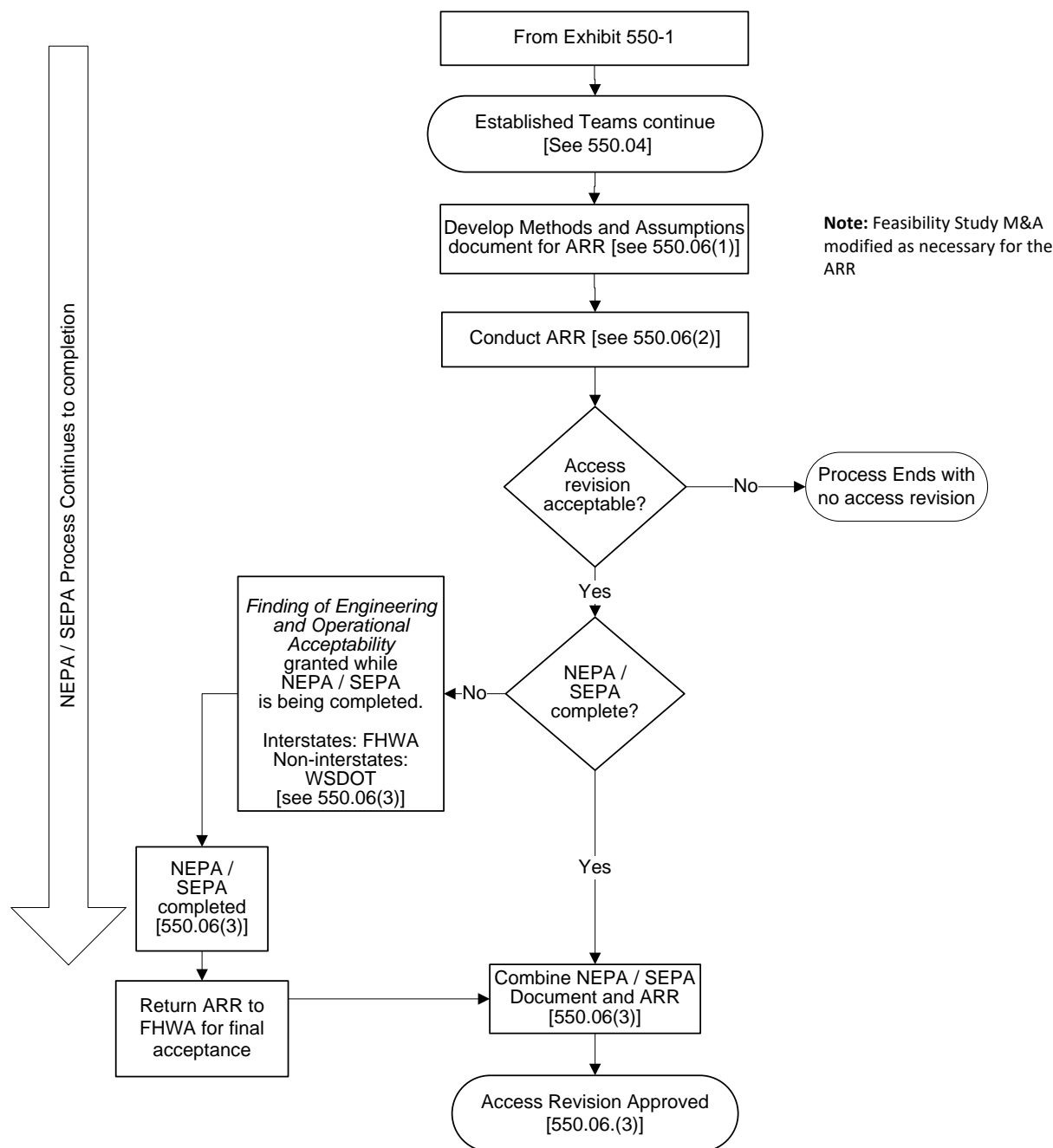
If the feasibility study indicates that addressing performance gaps cannot be reasonably achieved without revising freeway access, then write a purpose and need for access revision in this section of the feasibility study. This purpose and need statement should be written in close coordination with the Environmental Office as this is a key linkage point between the NEPA/SEPA process and the access revision process. The goal of this section is to provide a purpose and need statement that can be used for the Access Revision Report, a Basis of Design for an access revision, and the NEPA/SEPA process.

In addition to the purpose and needs statement, summarize the non-access alternatives that are needed and carried this list forward into the ARR.

## 550.06 Access Revision Report Process

In order to approve or reject a proposed revision to freeway access, specific analyses are to be completed and then documented in a technical report. This report is the Access Revision Report (ARR), previously known as an Interchange Justification Report (IJR). The proponents, with the help of the support team, prepares the ARR. One of the first steps should be the formation of the Executive Support Team. See section 550.04. Next develop a methods and assumptions document as outlined in section 550.05(2). The M&A document will be used to analyze the access revision and assist in developing the Access Revision Report.

Exhibit 550-2 Access Revision Report Process



## **550.06(1) Access Revision Report Method and Assumptions Document**

Begin by reevaluating the Non-Access Feasibility Study M&A to determine if it is applicable to the ARR. Pay attention to the sections on alternatives selection and assumptions. These two sections will likely change between the feasibility and the ARR phases. If there is no change, the Non-Access Feasibility M&A may be adopted by the executive committee. If a modification of the M&A is necessary, the executive committee has the ability to require a full rewrite or to agree to a scaled down effort for the ARR. If a full rewrite is necessary, follow the same outline as presented in Section 550.05(1) with the addition of allowing on-system improvements.

## **550.06(2) Access Revision Report**

The Access Revision Report addresses:

1. Reasonable Alternatives; see 550.06(2)(a)
2. Operational Analysis; see 550.06(2)(b)
3. Safety Performance Analysis; see 550.06(2)(c)
4. Conceptual Signing Plan; see 550.06(2)(d)

The following provides details for completing the Access Revision Report.

### **550.06(2)(a) ARR Reasonable Alternatives**

Consider alternatives in the Non-Access Feasibility Study that are carried forward into the ARR process and any new alternatives that may be developed for on-system alternatives. Then narrow the alternatives down to a few reasonable alternatives that will go through the evaluation process. Determine the reasonable alternatives for the ARR phase near the beginning of the process. This is necessary because the alternatives will set the course for the operational and safety analysis and determine exactly what must be analyzed.

The technical team evaluates each reasonable alternative with respect to operations and safety performance for all modes (see Section 550.06(2)(b) and (c)). Alternatives are refined based upon the results of the analysis and then presented to the executive support team for acceptance.

Conduct the alternatives selection and analysis process within the ARR with full consideration of the environmental process and environmental documentation that will be required. The ARR must be fully compatible with the corresponding environmental process. Include Region environmental staff in the alternatives selection process.

In the ARR document, include a description of the reasonable alternatives identified for consideration. At this point, you should have a few reasonable alternatives that will be carried forward through the whole ARR process and will have detailed operations and safety analysis conducted (see Section 550.06(2)(b) and (c)). The results of this analysis will be used to compare the alternatives and ultimately reach a preferred alternative. To document the evaluation criteria and the results of the analysis, use the Alternatives Comparison Table (ACT) or a similar tool.

### **Public Road Connection**

The ARR must show that the proposed access will connect to a public road network.



Less than “full interchanges” may be considered on a case-by-case basis for applications requiring special access, such as managed lanes (e.g., transit or high occupancy vehicle and high occupancy toll lanes) or park and ride lots.

In other cases where all basic movements are not provided by the proposed design, the ARR typically includes a full interchange option with a comparison of the operational and safety performance analyses to the partial-interchange option. The ARR should also include the mitigation proposed to compensate for the missing movements, including wayfinding signage, impacts on local intersections, mitigation of driver expectation leading to wrong-way movements on ramps, etc. The ARR should demonstrate that the future provision of a full interchange is not precluded by the proposal or describe how that future decision will be accommodated.

The crossroad must address the needs of all modes that are supported by the land use and demographics of the area. While the needs and priority of multimodal users are identified in the feasibility study, the ARR helps ensure multimodal needs are incorporated in the design.

### Design Standards and Criteria

FHWA policy requires that AASHTO Interstate standards (A Policy on Design Standards – Interstate System, AASHTO, latest edition) are used. This Design Manual provides criteria to meet FHWA and WSDOT policy on geometric standards. To achieve design standards requirements, apply the criteria in these key Design Manual Chapters:

- **Chapters 1100 – 1106** for an overview of practical design procedures, development of need statements, procedures for selecting appropriate multimodal design controls and design element dimensions. Assume the crossroad design will have implications and effects on all travel modes legally allowed. Provide obvious traffic control for all modes.
- **Chapters in the 1200 series** provide geometrics including plan and profile elements and freeway and other roadway type cross section criteria. **Chapter 1232** provides geometric cross section dimensions for Interstate and non-Interstate freeways. Other chapters in this series provide cross section criteria for roadway types which could apply to multimodal crossroads and local street or roadway contexts.
- **Chapters in the 1300 series** provide design criteria for Interchange spacing and design, and procedures for evaluating intersection control types. **Chapters 1300** - Intersection Control Type and **1360** - Interchanges
- **For special interchanges for HOV or Transit**, see chapters in the **1400** series.
- **Chapters in the 1500 series** provide design guidance for pedestrian and bicyclist facilities.
- **See other chapters** as applicable for various aspects of design and approvals.

### 550.06(2)(b) ARR Operational Analysis

The operational analysis for the ARR builds upon the operational analysis from the feasibility study. If demonstrated in the feasibility study that local solutions will not completely satisfy the Purpose and Need, the scope of the ARR operational analysis includes reasonable alternatives that consider revisions in freeway access as well as non-access improvements that are carried forward from the Non-Access Feasibility Study. This analysis must conclude that the proposed change in access does not have a significant adverse impact on the safety and operation of the

freeway facility or on the local street network for all modes, based on both current and planned future traffic projections. The freeway facility includes the main line lanes, collector-distributor lanes, existing, new, or modified ramps, and ramp intersections with crossroad.

The following are typical requirements for the analysis. The technical support team makes the ultimate decisions on transportation operational and safety performance analysis requirements. However, FHWA policy suggests the following expectations.

- The analysis includes, particularly in urbanized areas, a minimum of the first adjacent existing or proposed interchange on either side of the proposed change in access.
- The crossroads and the local street network, to a minimum of the first major intersection on either side of the proposed change in access, should be included in this analysis to the extent necessary to fully evaluate the safety performance and operational impacts that the proposed change in access and other transportation improvements may have on the local street network.
- The requested proposed change in access should include a description and assessment of the impacts and ability of the proposed changes to collect, distribute, and accommodate traffic on the Interstate facility, ramps, intersection of ramps with crossroad, and local street network.

#### **Intersection Control Evaluation**

The Access Revision Report also includes fulfilling the requirements of the Intersection Control Evaluation (ICE) to verify the chosen intersection(s) control at the interchange are adequate for all modes. An ICE will not be required if the ARR documents the criteria required for an ICE. See [Chapter 1300](#) for ICE instruction.

#### **550.06(2)(c) ARR Safety Analysis**

Conduct a safety performance analysis per [Chapter 321](#) and Section 8.1 of the [Safety Analysis Guide](#). For the ARR, discuss the safety performance of the reasonable alternatives. Use the results of the safety performance analysis to compare alternatives.

#### **550.06(2)(d) ARR Signing Plan**

Include a conceptual plan of the type and location of the signs proposed for the preferred alternative to support the Access Revision Report. The conceptual plan is typically limited to guide signage, but regulatory or warning signs may be required if the interchange configuration is unusual.

### **550.06(3) Access Revision Report Review and Approval**

[Exhibit 550-3](#) provides a template for approvals and concurrence signatures.

**Draft ARR review:** The draft ARR is first reviewed by the executive and technical support teams. After their review, the Region submits an electronic copy (in PDF format), including appendices, to the ASDE along with a cover memo requesting review. The ASDE responds in writing either with needed revisions or to request the final draft.

**Final ARR Submittal:** For final submittal, send the final ARR in PDF format to the ASDE. Contact the ASDE for the necessary number of hard copies. The Region submits a memo to the

appropriate ASDE, requesting final approval of the ARR. After ASDE concurrence, the ASDE submits Interstate ARRs to FHWA for approval.

ARR Approvals can be a two-step process:

- If environmental documentation is not complete, teams can request a finding of engineering and operational acceptability. FHWA grants this for Interstate access revisions and WSDOT grants for non-interstate.
- If the environmental documentation is complete, teams request final ARR approval.

Interstate Approval Notes:

- Interstate Access Revision Reports are most often reviewed and approved by the Washington FHWA Division Office. A 30-day review period must be allowed for the FHWA Division Office. Occasionally they are sent to FHWA Headquarters Office in Washington, DC (see [Exhibit 550-4](#)). If this is the case, additional review time is necessary.

FHWA provides final approval of the Interstate ARR when the appropriate final environmental document is complete: CE, FONSI, or ROD. The intent of the federal policy is to create a clear link between the ARR and NEPA processes. The ARR may be used as the transportation discipline report for an EIS/EA or included as an attachment to a CE. Coordinate with the Region Environmental Staff to integrate the ARR with the environmental documentation.

WSDOT provides final approval of the non-Interstate ARR when the appropriate final environmental document is complete.

#### **550.06(4) Updating the Access Revision Report**

The period between the approval of the Access Revision Report, completion of the environmental documentation, and the construction contract commonly spans several years. If the period exceeds three years, the approved ARR must be reviewed to identify changes that may have occurred during this period. If there have been little or no changes, an extension of the period may be granted. In this case, write a summary assessment for approval by the Region Traffic Engineer, ASDE, and FHWA.

If no work has begun within three years of completion of the environmental documentation, a re-evaluation of the CE/EA/EIS may be required (see [Environmental Manual 400.06\(1\)](#)). Contact the Region Environmental Office to determine if the environmental documentation must be re-evaluated.

#### **550.07 Documentation**

This chapter discusses in detail the requirements for the following documents:

- Non-Access Feasibility Study Method and Assumptions
- Non-Access Feasibility Study
- Access Revision Report Method and Assumptions
- Access Revision Report

For levels of approval for each of these documents, refer to [Exhibit 550-4](#) and [Chapter 300](#).

The final Access Revision Report is archived by the [HQ Access and Hearings Section](#).

## 550.08 References

### 550.08(1) Federal/State Laws and Codes

[23 Code of Federal Regulations \(CFR\) Part 450](#) (implementing 23 United States Code [USC] Section 135)

[40 CFR Parts 51](#) and [93](#) (regarding federal conformity with state and federal air quality implementation plans)

[23 USC Sections 111](#) (requires the U.S. Secretary of Transportation to approve access revisions to the Interstate System), [134](#) (metropolitan transportation planning), and [135](#) (statewide transportation planning)

FHWA Interstate Access Policy, update May 22, 2017.  
<https://www.fhwa.dot.gov/programadmin/fraccess.cfm>

### 550.08(2) Design Criteria and Supporting Information

Design Manual, [Chapter 320](#), Traffic Analysis

Design Manual, [Chapter 321](#), Sustainable Safety

Environmental Manual, [Chapter 200](#), Planning

Environmental Manual, [Chapter 400](#), NEPA/SEPA

WSDOT, NEPA/SEPA Guidance:  
<http://www.wsdot.wa.gov/Environment/Compliance/default.htm>

Safety Analysis Guide, WSDOT; See Sustainable Highway Safety Tools here:  
<http://www.wsdot.wa.gov/Design/Support.htm>

WSDOT Design support <http://www.wsdot.wa.gov/Design/Support.htm>  
Use the Design Support website to download the Context and Modal Accommodation report, Basis of Design, and Alternatives Comparison Table.

WSDOT Planning: find resources including Corridor Sketch Initiative, Corridor Planning Studies, links to the Highway System Plan, and other supporting information.  
<http://www.wsdot.wa.gov/planning/default.htm>

WSDOT Transportation Corridor Planning Studies  
<https://www.wsdot.wa.gov/publications/manuals/fulltext/M3033/PSGC.pdf>

WSDOT HQ Access and Hearings (including Freeway Access Revisions Resource Document)  
[www.wsdot.wa.gov/design/accessandhearings](http://www.wsdot.wa.gov/design/accessandhearings)

FHWA Traffic Analysis Toolbox (tools used in support of traffic operations analyses)  
[www.ops.fhwa.dot.gov/trafficanalysistools/index.htm](http://www.ops.fhwa.dot.gov/trafficanalysistools/index.htm)

FHWA Environmental Review Toolkit  
<https://www.environment.fhwa.dot.gov/default.aspx>

Highway Capacity Manual, (HCM) 2010, Transportation Research Council

Highway Safety Manual (HSM), AASHTO, 2010

[Local Agency Guidelines](#) (LAG), M 36-63, WSDOT

[NEPA Categorical Exclusions A Guidebook for Local Agencies](#), WSDOT

**Exhibit 550-3 Access Revision Report: Stamped Cover Sheet Example**

**Access Revision Report "Title"**

**"MP to MP"**

This **Access Revision Report** has been prepared under my direct supervision, in accordance with Chapter 18.43 RCW and appropriate Washington State Department of Transportation manuals.

**ARR Engineer of Record**

By: \_\_\_\_\_ P.E.

Date: \_\_\_\_\_

**Traffic Analysis Engineer**

By: \_\_\_\_\_ P.E.

Date: \_\_\_\_\_

**WSDOT Approval –  
Assistant State Design Engineer**

By: \_\_\_\_\_ P.E.

Date: \_\_\_\_\_

**FHWA Approval –  
FHWA Safety and Design Engineer**

By: \_\_\_\_\_

Date: \_\_\_\_\_

**Concurrence –  
Region Traffic Engineer**

By: \_\_\_\_\_ P.E.

Date: \_\_\_\_\_

Exhibit 550-4 Access Revision Documentation and Review/Approval Levels

Project Type	Support Team	Required Documentation		Interstate		Non-Interstate
		NAFS*	ARR*	Concurrence	Approval	HQ
New freeway-to-freeway interchange	Yes	✓	✓	FHWA and HQ	FHWA DC	Approval
Revision to freeway-to-freeway interchange in a Transportation Management Area <sup>[1][2]</sup>	Yes	✓	✓	FHWA and HQ	FHWA DC	Approval
New partial interchange	Yes	✓	✓	FHWA and HQ	FHWA DC	Approval
New freeway-to-crossroad interchange	Yes	✓	✓	HQ	FHWA	Approval
Revision to freeway-to-freeway interchange not in a Transportation Management Area <sup>[2]</sup>	Yes	✓	✓	HQ	FHWA	Approval
Revision to freeway-to-crossroad interchange, including but not limited to: <sup>[2]</sup> 1. Adding entrance or exit ramps that complete basic movements 2. Changing I/C configuration (e.g. diamond to SPUI, DDI, etc.) 3. Adding loop ramp to existing diamond 4. Adding on-ramp lanes that increase mainline entry point(s)	Yes	✓	✓ <sup>[4]</sup>	HQ	FHWA	Approval
Revision to freeway-to-crossroad interchange, including but not limited to: <sup>[3]</sup> 1. Intersection control at ramp terminal(s) 2. Adding lanes to on-ramps/off-ramps without revising the entry/exit points	No	[5]	✓ <sup>[4]</sup>	HQ and FHWA		Approval
New HOV direct access	Yes	✓	✓	HQ	FHWA	Approval
Transit flyer stop on main line	No	[5]	✓ <sup>[4]</sup>	HQ and FHWA		Concurrence
Transit flyer stop on a ramp	No	[5]	✓ <sup>[4]</sup>	HQ and FHWA		Concurrence
Abandonment of a ramp	No	[5]	✓ <sup>[4]</sup>	HQ	FHWA	Concurrence
Locked gate	<b>See Chapter 530</b>					
Access breaks that do not allow any type of access to main line or ramps (i.e. access doors in noise walls, gates to storm water retention/detention facilities from outside limited access, etc.)						
Structure over or under with no ramps (including pedestrian, bike, or trail)						
Construction/emergency access break						

\* NAFS = Non-Access Feasibility Study, ARR = Access Revision Report. For notes, see next page.

**Exhibit 550-4 (cont.) Access Revision Documentation and Review/Approval Levels****Notes:**

- [1] Washington Transportation Management Areas include Southwest Washington Regional Transportation Council (RTC) (Clark County), Puget Sound Regional Council (PSRC) (King, Kitsap, Pierce, and Snohomish Counties), and Spokane Regional Transportation Council (SRTC) (Spokane County).
- [2] “Revision” includes changes in interchange configuration even if the number of access points does not change. Changing from a cloverleaf to a directional interchange is an example of a “revision.”
- [3] “Revision” includes changes that might adversely affect the level of service of the through lanes. Examples include: doubling lanes for an on-ramp with double entry to the freeway; adding a loop ramp to an existing diamond interchange; and replacing a diamond ramp with a loop ramp. Revisions to the ramp terminal intersections may not require an ARR unless the traffic analysis shows an impact to the main line traffic.
- [4] The scale and scope of the access revision dictate the level of effort needed. Consult the Assistant State Design Engineer (ASDE), Region Traffic, and the FHWA Area Engineer, if applicable, for direction.
- [5] Consult the Region Planning Manager for the status of planning at this location.



- Maintenance personnel assessment of the electrical safety of the installation.

Involve appropriate Headquarters (HQ) and region Traffic Office design personnel early in the process. Ensure potential system deficiencies are reflected in the estimate of work.

Maintain required illumination during all construction activities, except when shutdown is permitted to allow for alterations or final removal of the system per the Engineer. Site preparation, widening, drainage, guardrail installation, or other work can easily impact existing conduit runs or luminaire locations. Also, changed conditions such as merging, weaving, or unusual alignment due to traffic control often require additional temporary illumination.

**Note:** The same lighting requirements apply whether a condition is temporary or permanent.

Illumination is not required for minor operational enhancement projects, unless that is the specific reasoning for the project.

## 1040.04 Required Illumination

The following items are to be considered for each project:

- Replace standard duty junction boxes that are located in paved areas with heavy-duty junction boxes, and bring electrical components to current standards. Relocate/remove junction boxes that are located in the travel way when practical.
- Review the age of the equipment as listed in SIMMS and consider replacing components that have reached the end of their design life. Replace poles, foundations, heads, and other equipment, that have reached their design life.
- Locate components so that they can be safely accessed from the right of way.
- Ensure existing slip base features are in accordance with current design standards.
- Consider additional illumination in accordance with [1040.05](#), if warranted, or design additional illumination if it is called for in the Project Definition.
- When it is necessary to relocate existing light standard foundations, evaluate the entire conduit run serving those light standards and replace deficient components to current (NEC) standards.

Exhibits [1040-1a](#) through [1040-21](#) show examples of illumination for roadway, transit flyer stops, parking lots, truck weigh stations, tunnels, bridges, work zones, and detour applications.

A minimum of two light standards of standard pole height are required at all design areas, with the exception of some ramp terminals, entrance/exit points at minor parking lots, and basic transit stop lighting.

### 1040.04(1) Freeway Off-Ramps and On-Ramps

Provide the necessary illumination for the design area of all freeway off-ramp gore areas and on-ramp acceleration tapers (see [1040.06\(2\)](#) and Exhibits [1040-1a](#), [1b](#), and [1c](#)).

### 1040.04(2) Freeway Ramp Terminals

Provide the necessary illumination for the design area (see [Exhibit 1040-2](#)). Ramp terminals may use a single light standard where all of the following are true:

- The ramp terminal is stop controlled (no traffic signal).
- The on and off-ramps are a single lane, regardless of width.
- The cross street is two lanes with no channelization.
- There are no sidewalks or marked crosswalks.

Verify with the HQ Traffic Office that the location is acceptable for a single light standard.

### **1040.04(3) Freeway On-Ramps With Ramp Meter Signals**

Provide the necessary number of light standards to illuminate freeway on-ramps with ramp meters, from 150' before the ramp meter stop bar to 50' past the ramp meter stop bar. When there is an HOV bypass lane or a two-lane merge beyond the ramp meter, then also provide illumination from the point where the merging lane width is 10' to 200' downstream of that point (see [Exhibit 1040-3](#)). Illumination for the ramp merge with mainline is to be done per [Exhibit 1040-1b](#).

### **1040.04(4) HOT (High-Occupancy Toll) Lane Enter/Exit Zones and Access Weave Lanes**

Provide the necessary number of luminaires to illuminate the design area of the enter/exit zones and access weave lanes of the HOT lane (see Exhibits [1040-4a](#) and [4b](#)).

### **1040.04(5) Lane Reduction**

Provide the necessary number of light standards to illuminate the design area of all highway lane reduction areas within the urban boundary (see [Exhibit 1040-5](#)). This requirement does not apply to:

- The end of slow-moving vehicle turnouts.
- The end of the area where driving on shoulders is allowed.

### **1040.04(6) Intersections With Left-Turn Lane Channelization**

Illumination of the intersection area is required for intersections with painted or other low-profile pavement markings such as raised pavement markings. When the channelization is delineated with curbs, raised medians, or islands, illuminate the raised channelization on the State Route from 25' before the raised channelization begins (see Exhibits [1040-6a](#), [6b](#), and [6c](#)).

### **1040.04(7) Intersections With Traffic Signals**

Illuminate intersections with traffic signals on state highways (see [Exhibit 1040-7](#)). In cities with a population under 27,500, the state may assume responsibility for illumination installed on signal standards.

### **1040.04(8) Roundabouts**

Provide the necessary number of light standards to illuminate the design areas of roundabouts (see [Chapter 1320](#) and [Exhibit 1040-9](#)).

### **1040.04(9) Railroad Crossings with Gates or Signals**

Railroad crossings with automated gates or signals on state highways are illuminated if there is nighttime train traffic. Within the corporate limits of a city, and outside limited access control, illumination is the responsibility of the city. Install luminaires beyond the railroad crossing, on the side of the roadway opposite the approaching traffic, to backlight the train (see [Exhibit 1040-10](#)).

### **1040.04(10) Midblock Pedestrian Crossings**

Illuminate the entire midblock pedestrian crossing, including the crosswalks, the refuge area in the roadway, and the sidewalks or shoulders adjacent to the crosswalk. When a raised median pedestrian refuge design is used, illuminate the raised channelization (see [Exhibit 1040-11](#)).

### **1040.04(11) Transit Flyer Stops**

Illuminate the pedestrian-loading areas of transit flyer stops, as described in Chapter [1420](#) (see [Exhibit 1040-12](#)). For all other types of transit stops, see [1040.05\(8\)](#).

### **1040.04(12) Major Parking Lots**

All parking lots with usage exceeding 50 vehicles during the nighttime peak hour are considered major parking lots. Provide an illumination design that will produce the light levels shown in [Exhibit 1040-22](#). (See [Exhibit 1040-13](#) for the parking design area and bus loading zone design area.) During periods of low usage at night, security lighting is required only in the parking area and bus loading zone. Provide an electrical circuitry design that allows the illumination system to be reduced to approximately 25% of the required light level.

### **1040.04(13) Minor Parking Lots**

Minor parking lots have a nighttime peak hour usage of 50 or fewer vehicles. Provide security-level lighting for those lots owned and maintained by the state. Security lighting for a minor parking lot consists of lighting the entrance and exit to the lot (see [Exhibit 1040-14](#)).

### **1040.04(14) Truck Weigh Sites**

Provide illumination of the roadway diverge and merge sections, scale platforms, parking areas, and inspection areas of weigh sites (see [Exhibit 1040-15](#)).

### **1040.04(15) Safety Rest Areas**

Provide illumination within rest areas at the roadway diverge and merge sections, the walkways between parking areas and rest room buildings, and the parking areas the same as for a major parking lot (see [Exhibit 1040-16](#)).

### **1040.04(16) Chain-Up/Chain-Off Parking Areas**

Provide the necessary number of luminaires to illuminate the design area of the chain-up/chain-off parking areas (see [Exhibit 1040-17](#)) on State Routes 2, 12, and 90 where a power distribution point is within a half mile and power is readily accessible. Illumination is to be installed in the median and on the right shoulder to provide lighting on both sides of the stopped vehicles.

Luminaires should only be energized during periods when traction tires are required and vehicles over 10,000 pounds are required to use chains.

### **1040.04(17) Tunnels, Lids, and Underpasses**

For the purposes of this chapter, a tunnel is a structure over a roadway, which restricts the normal daytime illumination of a roadway section such that the driver's visibility is substantially diminished. Tunnels cover roadways and produce a shadow that limits the ability of the driver to see objects or obstructions within the tunnel. In most locations, no supplemental daytime lighting is required for underpasses or structures less than 80 feet in length. Provide both nighttime and daytime lighting for long tunnels. (See ANSI/IES publication RP-22-11 for tunnel lighting design criteria.) Provide vandal-resistant daytime and nighttime security lighting in pedestrian tunnels. Short tunnels and underpasses where the exit portal is not visible from the entrance portal due to curvature of the roadway are to be considered long tunnels.

### **1040.04(18) Bridge Inspection Lighting**

Provide the necessary number of light fixtures and electrical outlets to illuminate the interior inspection areas of floating bridges, steel box girder bridges and concrete box girder bridges where access is provided (see [Exhibit 1040-18](#)). Separate circuits are to be used for lighting and electrical outlets. Each electrical outlet is to be powered by 2 Duplex receptacles on two separate circuits. All electrical outlets are to be labeled with circuit identifications. Coordinate bridge illumination requirements with the HQ Bridge and Structures Office.

### **1040.04(19) Same Direction Traffic Split Around an Obstruction**

Provide the necessary number of light standards to illuminate the design area where traffic is split around an obstruction. This requirement applies to permanent and temporary same-direction split channelization. For temporary work zones, illuminate the obstruction for the duration of the traffic split (see [Exhibit 1040-19](#)).

### **1040.04(20) Diverging Diamond Interchange**

Provide the necessary number of light standards to illuminate the design area shown in [Exhibit 1040-21](#). The design area starts 25' before the raised channelization as you approach the interchange and continues through the interchange until 25' past the raised channelization as you exit the interchange.

## **1040.05 Additional Illumination**

At certain locations, additional illumination is desirable to provide better definition of nighttime driving conditions or to provide consistency with local agency goals and enhancement projects. For Improvement projects on state highways, additional illumination could be reviewed as a crash countermeasure under certain circumstances, which are listed in this section.

### **1040.05(1) Conditions for Additional Illumination**

Following are some conditions used in making the decision to provide additional illumination:

approval of the State Traffic Engineer. For justification for illuminating pedestrian walkways or bicycle trails under a bridge, see [1040.05\(11\)](#).

### **1040.05(10) Railroad Crossing Without Gates or Signals**

Consider the illumination of railroad crossings without gates or signals when:

- The crash history indicates that motorists experience difficulty in seeing trains or control devices.
- There are a substantial number of rail operations conducted during nighttime hours.
- The crossing is blocked for long periods due to low train speeds.
- The crossing is blocked for long periods during the nighttime.

For further information, see the MUTCD.

### **1040.05(11) Sidewalks, Walkways, and Shared-Use Paths**

Consider illumination of a pedestrian walkway if the walkway is a connection between two highway facilities. This could be between parking areas and rest room buildings at rest areas; between drop-off/pick-up points and bus loading areas at flyer stops; or between parking areas and bus loading areas or ferry loading zones. Consider illuminating existing sidewalks, walkways, and shared-use paths if security problems have been reported or are anticipated. Under these conditions, these facilities are illuminated to the level shown in [Exhibit 1040-22](#).

## **1040.06 Design Criteria**

### **1040.06(1) Light Levels**

Light levels vary with the functional classification of the highway, the development of the adjacent area, and the level of nighttime activity. Light level requirements for highways and other facilities are shown in [Exhibit 1040-22](#). These levels are the minimum average light levels required for a design area at the end of rated lamp life for applications requiring a spacing calculation. Light level requirements are not applicable for single light standards or security lighting installations where:

- The light level is reduced to approximately 25% of the required light level in parking lots and parking lot loading areas during periods of low usage at night.
- Walkway or path illumination is installed only at areas where shadows and horizontal and vertical geometry obstruct a pedestrian's view.

Light level requirements still apply when the complete walkway or path is to be illuminated for public safety.

The access areas used for interior inspection of floating bridges or steel box/concrete box girder bridges are exempt from lighting level and lighting ratio design requirements.

For functional classifications of highways, see:

[www.wsdot.wa.gov/mapsdata/travel/hpms/functionalclass.htm](http://www.wsdot.wa.gov/mapsdata/travel/hpms/functionalclass.htm)

### **1040.06(1)(a) Activity Areas**

The types of activity areas (shown below) are related to the number of pedestrian crossings through the design area. These crossings need not occur within a single crosswalk and can be at several locations along the roadway in an area with pedestrian generators. Land use and activity classifications are as follows:

#### **1040.06(1)(a)(1) High Activity**

Areas with over 100 pedestrian crossings during nighttime peak hour pedestrian usage. Examples include downtown retail areas; near outdoor stage theaters, concert halls, stadiums, and transit terminals; and parking areas adjacent to these facilities.

#### **1040.06(1)(a)(2) Medium Activity**

Areas with pedestrian crossings that number between 11 and 100 during nighttime peak hour pedestrian usage. Examples include downtown office areas; blocks with libraries, movie theaters, apartments, neighborhood shopping, industrial buildings, and older city areas; and streets with transit lines.

#### **1040.06(1)(a)(3) Low Activity**

Areas with pedestrian crossings that number less than 11 during the nighttime peak hour pedestrian usage. Examples include suburban single-family areas, low-density residential developments, and rural or semirural areas.

### **1040.06(2) Design Areas**

The design area is that portion of the roadway, parking lot, or other facility subject to the minimum light level, minimum average light level, uniformity ratio, and maximum veiling luminance ratio design requirements. This encompasses the area between the edges of the traveled way along the roadway; the outer edges of the stopping points at intersections; and, when present, a bike lane adjacent to the traveled way. When the roadway has adjacent sidewalks and is located in a medium or high pedestrian activity area, the design area includes these features; however, sidewalks adjacent to the traveled way are exempt from maximum veiling luminance ratio requirements.

#### **1040.06(2)(a) Design Area Requirements**

Design area requirements for various applications are shown in [Exhibits 1040-1a](#) through [1040-21](#) and are described in the following:

##### **1040.06(2)(a)(1) Single-Lane Off-Ramp**

Two main line through lanes and the ramp lane, including gore area, from the gore point (beginning of wide line) to a point 200 feet (minimum) downstream of the gore point. A 100 foot longitudinal tolerance either way from the gore point is allowed.

##### **1040.06(2)(a)(2) Two-Lane Off-Ramp**

Two main line through lanes and both ramp lanes, including gore area, from a point 200 feet upstream of the gore point (beginning of wide line) to a point 200 feet downstream of the gore point. A 100-foot longitudinal tolerance either way from the gore point is allowed.

## 1040.06(4) Light Standards

### 1040.06(4)(a) Light Standards on State Highway Facilities

Light standards are the most common supports used to provide illumination for highway facilities. The 40-foot light standard with a slip bases and Type 1 mast arm is predominantly used on state highways. In areas with continuous illumination, 50-foot light standards may be used. Use Type 1 mast arms on all new systems and when modifying existing systems. Cities and counties may elect to use different mounting heights to address factors unique to their environments. On state highways, alternative colored light standards may be considered if requested by the city or county, provided they agree to pay any additional costs associated with this change.

The typical location for a light standard is on the right shoulder. When considering designs for light standards mounted on concrete barrier in the median, consider the total life cycle cost of the system, including the user costs resulting from lane closures required for relamping and repair operations, and higher maintenance costs since the work will most likely be done during night time hours due to decreased traffic volumes. Region Signal Maintenance approval is required for all median mounted luminaires except chain on/off areas. Light standards located in the vicinity of overhead power lines require a minimum 10 foot circumferential clearance from the power line (including the neutral conductor) to any portion of the light standard or luminaire. Depending on the line voltage, a distance greater than 10 feet may be required (WAC 296-24-960). Consult the HQ Bridge and Structures Office when mounting light standards on structures such as retaining walls and bridge railings.

It is preferable to locate a light standard as far from the traveled way as possible to reduce the potential for impacts from errant vehicles. The typical luminaire position is mounted directly over the edge line plus or minus 4 feet. However, some flexibility is acceptable with the luminaire position to allow for placement of the light standard provided light levels, uniformity, and maintenance considerations are addressed, and with the Region Traffic Engineer's approval. On Type III signal standards, luminaires may be placed more than 4 feet from the edge line.

Standard mast arm lengths are available in 2-foot increments between 6 and 16 feet. The preferred design for a single-arm light standard is a 16-foot mast arm installed on a 40-foot standard. The maximum allowable mast arm length for a single-arm light standard is 16 feet. The preferred design for a double mast arm light standard has mast arms between 6 feet and 12 feet in length, installed on a 40-foot standard. The maximum allowable mast arm length for a double luminaire light standard is 12 feet.

Light standards should always use slip bases, unless a fixed base is justified as described in [Chapter 1610](#).

- In curb and sidewalk sections, locate the light standard behind the sidewalk. In locations where the light standard cannot be placed behind the sidewalk and still have the luminaire mounted within 4' of the edge line, the luminaire should be located in the sidewalk. When installed in the sidewalk, ensure that the minimum sidewalk width is available to at least one side of the light standard for the pedestrian access route (see [Chapter 1510](#)).



### 1040.06(4)(b) Light Standard Heights

Standard pole heights (20-foot, 30-foot, or 40-foot) are readily available from local distributors and manufacturers. Light standards can also be supplied with other lengths. However, WSDOT Maintenance offices cannot stock poles with nonstandard lengths for use as replacements in the event of a knockdown. Nonstandard lengths in 5-foot increments (25-foot, 35-foot, or 45-foot) will require a longer delivery time. Other nonstandard lengths (for example, 27-foot, 33-foot, or 37-foot) will not only require a longer delivery time, they will also be more expensive.

In almost all cases, use a standard pole heights of 40 feet for roadway illumination. Structure-mounted light standards may need to be shorter than the standard 40-foot grade-mounted pole. It is acceptable to use 20-foot or 30-foot light standards on bridges, retaining walls, or other structures to compensate for top-of-structure elevation above the roadway surface. Luminaires with a mounting height over 40 feet should only be used in continuously illuminated areas that are not in residential areas. Use of these standard pole heights will result in variable mounting heights for the luminaires. Luminaire mounting height is defined as the actual distance from the roadway surface directly under the luminaire to the luminaire itself. Use the actual mounting height at each location when calculating light standard spacing. Luminaires with a mounting height over 50 feet require lowering devices.

High mast light supports may be considered for complex interchanges where continuous lighting is justified. High mast lighting may be considered for temporary illumination areas during construction. Initial construction costs, long-term maintenance, clear zone mitigation, spillover light onto adjacent properties, and negative visual impacts are important factors when considering high mast illumination.

Shorter light standards of 30 feet or less may be used for minor parking lots, trails, pedestrian walkways, and locations with restricted vertical clearance.

### 1040.06(4)(c) Standard Luminaire

The standard luminaire in use now for roadway lighting is a cobra head style type III LED fixture. The list of LED fixtures approved for use on WSDOT projects can be found at:

🔗 <http://www.wsdot.wa.gov/Design/Traffic/ledluminaires.htm>

For continuously illuminated area a type V distribution pattern can be used for the interior areas with type III distribution on the perimeters.

### 1040.06(4)(d) Electrical Design

For an example of circuit layout, conductor sizing, conduit sizing, overcurrent protection device sizing, and other electrical design calculations, see the Power Supply Design material located at:

🔗 <http://www.wsdot.wa.gov/design/traffic/electrical/training.htm>

An example of illumination design grid layouts and calculations is located in the Illumination Design for Transportation Applications material located in the link above.

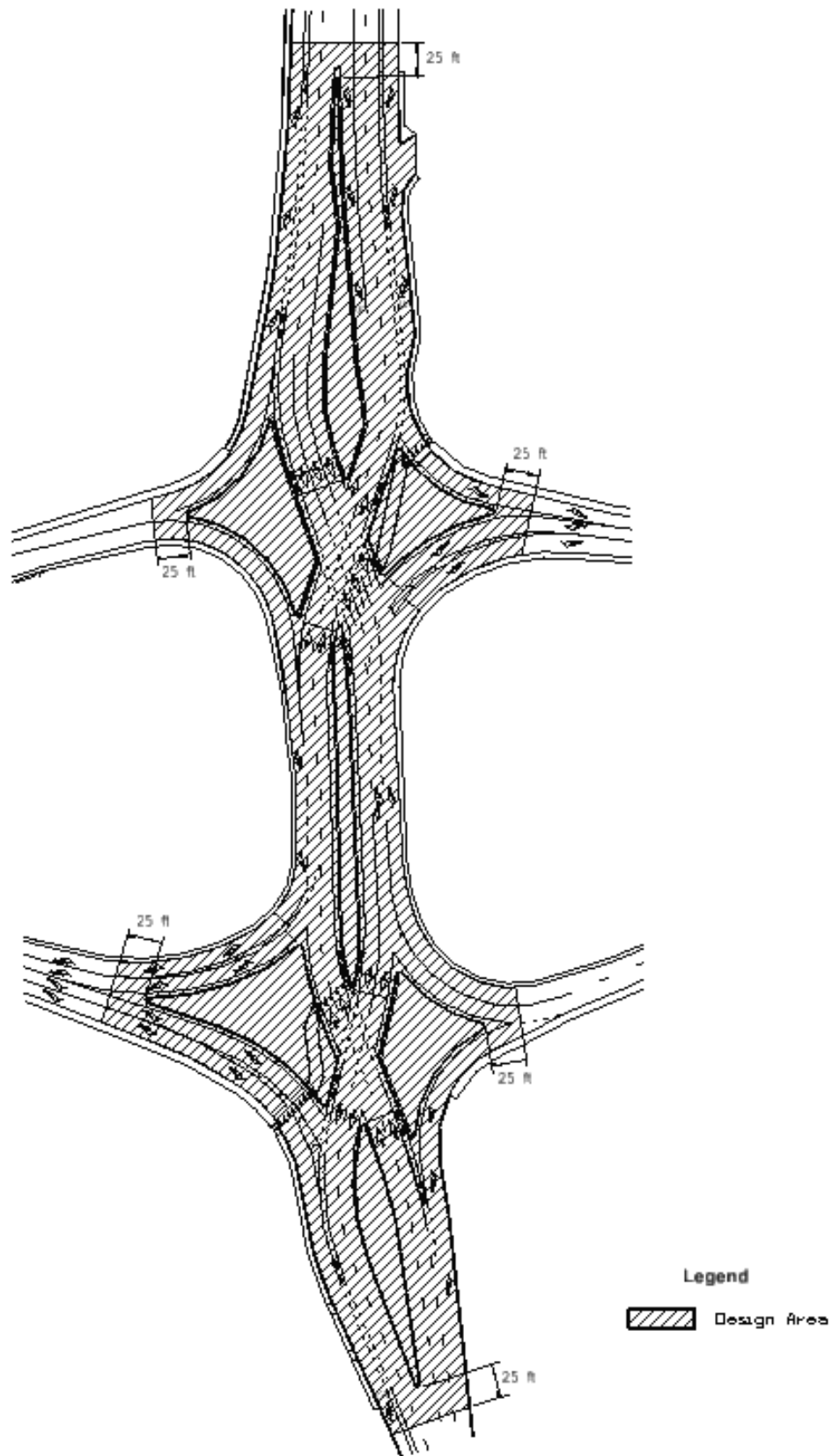
The illumination circuitry is to be laid out so that if four or more luminaires are installed, it should have a minimum of two circuits. The intent is to make sure that if a circuit fails, there will still be partial lighting from the other circuits.

The maximum allowable junction box spacing is as follows:

1. 360 feet allowed between in grade junction boxes with a straight pull.



Exhibit 1040-21 Diverging Diamond Interchange



## Exhibit 1040-22 Light Levels and Uniformity Ratios

Light Level and Uniformity Ratio Chart					
Highway Design Class	Minimum Average Maintained Horizontal Light Level			Maximum Uniformity Ratio <sup>[5]</sup>	Maximum Veiling Luminance Ratio <sup>[6]</sup>
	Pedestrian/Area Classification				
	High (footcandles)	Medium (footcandles)	Low (footcandles)		
<b>Highways With Full Access Control</b> <sup>[1][8]</sup>					
Main Line	0.6	0.6	0.6	4:1	0.3:1
Ramps	0.6	0.6	0.6	4:1	0.3:1
Crossroads	0.6	0.6	0.6	4:1	0.3:1
Ramp Intersections	0.9 <sup>[2]</sup>	0.9 <sup>[2]</sup>	0.9 <sup>[2]</sup>	4:1 <sup>[2]</sup>	0.3:1
<b>Highways Without Full Access Control</b> <sup>[3][8]</sup>					
Main Line	1.2	0.9	0.6	4:1	0.3:1
Intersections	1.2	0.9	0.9	4:1	0.3:1
<b>Other Illuminated Features</b>					
Construction Lanes and Detours	1.0	1.0	1.0	4:1	0.3:1
Major Parking Lots/Rest Areas	0.8	0.8	0.8	4:1	0.3:1
Vehicle Inspection Areas	2.0	2.0	2.0	4:1	0.3:1
Sidewalks, Walkways & Shared Use Paths	0.8	0.8	0.8	4:1	0.3:1
Weigh Scales	0.8	0.8	0.8	4:1	0.3:1
Transit Stops <sup>[4]</sup>	2.0	2.0	2.0	NA <sup>[7]</sup>	0.3:1
Midblock Ped X-ing	2.0	2.0	2.0	4:1	0.3:1

**Notes:**

- [1] The minimum light level is 0.2 footcandle (fc) for any application with a minimum average maintained horizontal light level of 0.6 fc. The minimum light levels for all other applications are controlled by the uniformity ratio.
- [2] The minimum average maintained light level may be reduced to 0.6 fc and the uniformity ratio may be ignored when only one light standard is used. Also applies to minor parking lot entrances and exits, and basic transit stop lighting.
- [3] Light levels shown also apply to modified and partial limited access control.
- [4] For single light standard installations, provide the light level at the location where the bus stops for riders (see [Exhibit 1040-12](#)).
- [5] Minimum Average Maintained Light Level/Minimum Light Level = Maximum Uniformity Ratio.
- [6] Maximum Veiling Luminance/Average Luminance = Maximum Veiling Luminance Ratio.
- [7] The Maximum Uniformity Ratio is 4:1 when more than one light standard is justified.
- [8] Roundabout illumination shall meet intersection lighting requirements for the associated roadway classification.

- [1101.01 General](#)
- [1101.02 Baseline Needs](#)
- [1101.03 Contextual Needs](#)
- [1101.04 Contributing Factors Analysis](#)
- [1101.05 Project Need Statement](#)
- [1101.06 Documentation](#)
- [1101.07 References](#)

## 1101.01 General

Practical design starts with identification of issues associated with the performance of a transportation facility. First, one or more project needs associated with these issues are identified. These project needs represent the gap in performance between the existing and desired state. Once they are identified, a project need statement is then developed which expresses only the most fundamental causes of these performance gaps.

This chapter provides:

- Instruction on the different types of needs—baseline and contextual.
- A method to diagnose and analyze the contributing factors of the identified need.
- Instruction on how to determine performance metrics and targets for each of the identified needs.
- How to develop project need statements.

## 1101.02 Baseline Needs

A baseline need is the primary reason a project has been proposed at a location. The baseline need usually evolves from a WSDOT planning and/or priority programming process. There can be more than one baseline need such as when an agency partners with WSDOT on a project and the partner's need becomes another baseline need. It is important to consider the needs of all mode users.

**Example:** A local agency desires to fund a revitalization project for a community bordering a state highway. The local agency's baseline need in this case is the local land use's economic vitality. If WSDOT also happens to have a prioritized and funded baseline need at the same location, and the two parties decide to partner in a combined project, that project will have at least two baseline needs. The two parties will work to develop solutions compatible for both baseline needs.

To determine, develop, and refine the project's baseline need(s), examine the conditions surrounding the original project identification, which was completed in the priority programming phase.

After developing and refining the baseline need(s), define the baseline performance metrics. (see [1101.02\(1\)](#)) and determine the baseline need targets (see [1101.02\(2\)](#)).

## 1101.02(1) **Baseline Performance Metrics of the Baseline Need(s)**

Baseline performance metrics are those “measurables” used to check that the project satisfies the need(s). Baseline performance metrics are also used in the development of the project need statement. Project alternatives must address the identified baseline performance metric(s).

Threshold performance metrics are used in the priority programming process to screen the full state network under each performance category (for further information on threshold performance metrics and performance categories, see the guidance document Performance-Based Decisions: [www.wsdot.wa.gov/Design/Support.htm](http://www.wsdot.wa.gov/Design/Support.htm)). The baseline performance metric for preservation category projects is predetermined, and is the same as the threshold performance metrics determined by Subject Matter Experts (SMEs) and HQ Capital Program Development and Management (CPDM) Office.

The baseline performance metrics for a mobility or economic vitality category project may be different from the threshold performance metrics. However, the baseline metric chosen is to be consistent with the priority programming performance category that identified the location to be evaluated.

**Example:** A routinely congested corridor has been screened to identify locations with a potential mobility performance gap. Screening used a threshold performance metric of estimated operations at 70% of posted speed during the peak hour. After considering the context of the location, and the relevance of the threshold performance metric to the site specific conditions and operations, the advisory team recommends that travel time reliability is a more appropriate metric for the location.

WSDOT’s practical design approach is committed to multimodal safety as identified in Washington State’s Strategic Safety Plan (see [www.targetzero.com/plan.htm](http://www.targetzero.com/plan.htm)). To meet this commitment, projects are required to include a baseline performance metric for evaluating the number of fatal and serious injury crashes in safety, mobility and economic vitality category projects. Other safety metrics to address the specific community or partnering agency needs may be included as contextual needs.

Safety projects are expected to continue project development as directed by the Multimodal Safety Executive Committee (MSEC), and described in the Safety Scoping Flowchart and [Chapter 321](#).

Other projects are to coordinate up front with the HQ Safety Technical Group to determine the scale and scope of crash analyses appropriate for different types and sizes of projects. For additional information see [Chapter 321](#).

## 1101.02(2) **Baseline Performance Target**

Performance targets are the outcome (or desired state) intended for a project. Use baseline performance metrics and targets to compare alternative designs based on how well the alternative meets the selected targets relative to their costs. Targets can be a single value or range of values.

There may be situations where the targets cannot practicably be met by any alternative or where there are unacceptable performance trade-offs in other performance categories. In these situations it may be appropriate to accept performance trade-offs, in one of the other

categories during the alternatives evaluation (see [Chapter 1104](#)), in order to balance competing needs and outcomes. In other situations, it may be appropriate to refine the performance target under consideration.

### 1101.03 Contextual Needs

Practical design requires that designers refrain from overdesigning the project by focusing the solution on the baseline need or needs. In doing so, opportunities are provided by projects to address other needs that may be identified through community engagement and/or increased project knowledge and understanding. These other needs are classified as “contextual needs.” A contextual need is any identified need that is not a baseline need. Potential sources of contextual needs include:

- Performance gaps identified through the priority\_network screening that did not prioritize under a statewide biennial prioritization and budget exercise, but still exist at the project location.
- Needs identified through community engagement or identified by a partnering agency.
- Needs based on identified environmental regulations and constraints.
- Needs identified through coordination with WSDOT maintenance (see [Chapter 301](#) for additional information).
- Needs identified through increased knowledge of the project site and context.

Develop metrics for contextual needs to compare alternatives. Interpret and translate each issue into a statement that is measureable, to the extent feasible. Contextual need metrics can be either quantitative or qualitative.

#### 1101.03(1) Use in Alternative Formulation and Evaluation

Contextual needs serve a different role than baseline needs. Baseline needs primarily shape the alternatives developed, while contextual needs are important to the performance trade-offs discussion (see [Chapter 1104](#)). Not all contextual needs identified need to be addressed by a project. Contextual needs present opportunities for optimizing the design, provide for partnerships and modes, and ultimately determine the most optimal project alternative (in conjunction with SEPA/NEPA processes as discussed in [Chapter 1104](#)).

Whether a design alternative achieves a particular contextual performance target is a consideration during the tradeoffs analysis. When no alternative adequately balances performance, lower-cost countermeasures can be employed to help mitigate performance issues and improve the viability of alternatives. Modifications to one or more design controls are another approach that can be used to achieve performance targets (see [Chapter 1103](#)), without significantly burdening the alternative with additional cost. If all alternatives fail to find an acceptable performance balance targets may be refined. Performance targets are documented and approved as part of the Basis of Design approval process.

### 1101.04 Contributing Factors Analysis

Contributing factors analysis (CFA) is a process by which subject matter experts on the advisory team evaluate the contributing factors associated with performance gaps in order to identify the root reasons for each gap. In the transportation field, contributing factors are any geometric,

operational, context-based, or human factor that can reasonably be attributed to a performance need through data analysis and engineering judgment.

Practical design relies on CFA to find the root reason(s) a need exists, rather than focusing on a symptom that may only temporarily or partially resolve the need.

Note: It is recognized that completely solving a problem may not be possible by a single corrective action due to the number of contributing factors or because of constraints.

The CFA method will:

- Organize and identify multiple contributing factors and underlying root reasons.
- Formulate a number of potential countermeasures to solve the need as thoroughly and efficiently as possible.

Diagnosis of contributing factors yields the best results when data is available for the analysis. Comprehensive crash data, organized by travel mode, is important when considering safety performance. In other performance categories, where quantitative data is not available, qualitative analysis may be used to reveal the underlying contributing factor(s).

Contributing factor analysis is only required for evaluation of baseline performance needs. However, it may be relevant to perform CFA for contextual performance metrics.

Diagnosing contributing factors using CFA is not necessarily a simple linear process. It's possible to find that a contributing factor identified by one discipline is the root cause of another discipline's contributing factor. In some cases, mapping the contributing factors in a network or fishbone diagram can help identify these relationships more clearly (see the guidance document Contributing Factors Analysis: [www.wsdot.wa.gov/Design/Support.htm](http://www.wsdot.wa.gov/Design/Support.htm)).

## 1101.05 Project Need Statement

A project need statement (or statement of need) uses the baseline needs (see [1101.02](#)) and results of contributing factors analysis to succinctly describe the real root project need(s). The objective is to provide a clear, accurate plain talk description of the root needs that will facilitate the development of efficient, focused project alternatives. A need statement should:

- Identify the objective, in simple, direct terms.
- Identify the performance metric(s) involved.
- Include one or more quantifiable statements.
- Exclude any description or discussion of potential solutions.

Consider other processes applicable to their projects that may require need statements such as: value engineering, NEPA/SEPA, and [Access Revision Reports](#). Consider timing of these processes as well as integration and alignment of the need statements with the processes required for the project.

For more information and examples of need statements, see the guidance document Writing Effective Needs Statement: [www.wsdot.wa.gov/Design/Support.htm](http://www.wsdot.wa.gov/Design/Support.htm)

## 1101.06 Documentation

Use the Basis of Design, Section 1, to document decision-making and conclusions associated with project need identification.

Download The BOD here: [www.wsdot.wa.gov/Design/Support.htm](http://www.wsdot.wa.gov/Design/Support.htm)

## 1101.07 References

Contributing Factors Analysis, WSDOT Guidance Document:

[www.wsdot.wa.gov/Design/Support.htm](http://www.wsdot.wa.gov/Design/Support.htm)

Performance-Based Design, WSDOT Guidance Document:

[www.wsdot.wa.gov/Design/Support.htm](http://www.wsdot.wa.gov/Design/Support.htm)

Writing Effective Needs Statement, WSDOT Guidance Document:

[www.wsdot.wa.gov/Design/Support.htm](http://www.wsdot.wa.gov/Design/Support.htm)

Washington State's Strategic Safety Plan: [www.targetzero.com/plan.htm](http://www.targetzero.com/plan.htm)

WSDOT Safety Scoping Flowchart:

<http://wwwi.wsdot.wa.gov/ppsc/pgmmgt/wwwi/PlanProg/Scoping/SafetyScopingProcessFlowChart.pdf>





1102.01	<a href="#">General Overview</a>
1102.02	<a href="#">Land Use Context</a>
1102.03	<a href="#">Transportation Context</a>
1102.04	<a href="#">Documentation</a>
1102.05	<a href="#">References</a>

## 1102.01 General Overview

**Context** refers to the environmental, economic, and social features that influence livability and travel characteristics. Context characteristics provide insight into the activities, functions, and performance that can be influenced by the roadway design. Context also informs roadway design, including the selection of design controls, such as target speed and modal priority, and other design decisions.

For the purposes of transportation planning and design, WSDOT divides context into two categories: land use and transportation. Each of these contexts is further defined and categorized in this chapter. Note that context categories, and the information pertinent to deriving them, may have been documented in a planning study.

The concepts and method described in this chapter are adapted from National Cooperative Highway Research Program Report 855: “An Expanded Functional Classification System for Highways and Streets” (see <http://www.trb.org/NCHRP/Blurbs/176004.aspx>).

## 1102.02 Land Use Context

This section describes the procedure for determining the land use context category on non-freeway facilities. The guidance in this section does not apply for freeways (see [Chapter 1232](#) for the definition of a freeway). For freeways, Section 2 of the Basis of Design is used only to document the urban/rural designation as listed for the route on the State Route Log.

On larger projects, more than one land use category may apply within project limits.

### Step 1. Determine an initial land use context category (current state)

Land use context categories are described in detail in [1102.02\(1\)](#). These categories represent distinctive land use environments beyond simply “rural” and “urban” to help determine a more accurate context. These categories influence roadway design, including determining appropriate operating speeds, mobility and access demands, and modal users. The land use categories are:

- Rural
- Suburban
- Urban
- Urban Core

Use the following factors to determine your initial land use context category:

1. Land uses (primarily residential, commercial, industrial, and/or agricultural)
2. Density
3. Setbacks

Quantify these factors through an assessment of the area adjacent to the existing or planned roadway (see [Exhibit 1102-1](#)).

### Step 2. Determine an initial land use context category (future state)

Using the same factors and categories, consult with local agency staff, and review state, regional, and local planning documents to consider and document potential or anticipated changes to land use context. Sources of information include the local comprehensive plan, WSDOT Highway System Plan, WSDOT corridor sketches, and WSDOT planning studies in the corridor.

#### Exhibit 1102-1 Factors for Determining Initial Land Use Context

Factor	Criteria
Land Use	Land uses within ½ mi of roadway
Density	Housing units / acre
Density	Jobs / acre
Density	Intersections per sq. mi.
Density	Typical building height
Setback	Typical building setback
Setback	Parking (on street or off street)

Specific metrics guiding the use of these criteria in determining the initial land use context category (both current and future) are provided on the WSDOT Design Office website.

### Step 3. Select final land use context category (current and future state)

Once an initial land use category is determined, additional (primarily qualitative) considerations are used to verify that the selected category is appropriate. Because data used in the initial determination may be incomplete, conflicting, or difficult to interpret, it's expected that professional judgment is used to confirm the context result. Even when the overall assessment is clear, discontinuities or transitions between categories may exist and require further interpretation.

Confirm or make adjustments to the initial context category based on a qualitative analysis. Use information gathered from consultations with local agency staff, as well as the project's community engagement processes, to validate a final determination about current and future context. Information about topography, soil type, land value, population density, average building square footage, visual assessments, aerial photos, zoning, and other local agency land use data and/or maps may also be used in this step.

Document the process used to make this final context determination. Include the data used, interdisciplinary input, and issues encountered and resolved in the process. Conclude with a final land use context determination that confirms, or adjusts, the initial category(s) for the project, and seek the endorsement of this final determination from the project advisory team (see [Chapter 1100](#)).

## **1102.02(1) Land Use Categories**

The land use categories used to inform project design are described below.

### **1102.02(1)(a) Rural**

The rural category ranges from no development (natural environment) to some light development (structures), with sparse residential and other structures mostly associated with farms. The land is primarily used for outdoor recreation, agriculture, farms, and/or resource extraction. Occasionally non-incorporated communities will include a few residential and commercial structures. Rural characteristics also include:

- No or very few pedestrians – except those locations used for outdoor recreation and modal connections, and where socioeconomic factors suggest that walking is likely to serve as an essential form of transportation
- Bicycle use mostly recreational– except for tourist destinations, modal connection locations and between communities where bicycle commuters may be expected or where socioeconomic factors suggest that bicycling is likely to serve as an essential form of transportation.
- Low development density
- Isolated residential or commercial activities
- Commercial uses include general stores, restaurants, and gas stations, normally at crossroads
- Setbacks for structures are usually large, except in the immediate vicinity of small settlements
- Transit service availability is often absent or highly limited, but varies widely depending on the jurisdiction. On-demand service is typically found to provide specialized transportation services

### **1102.02(1)(b) Suburban**

Locations classified as suburban include a diverse range of commercial and residential uses that have a low or often, medium density. Suburban areas are usually (but not always) connected and closely integrated with an urban area. The buildings tend to be multi-story with off-street parking. Sidewalks are usually present and bicycle lanes may exist. These areas include mixed use town centers, commercial corridors, and residential areas. Big box commercial and light industrial uses are also common. The range of uses encompasses health services, light industrial (and sometimes heavy industrial), quick-stop shops, gas stations, restaurants, and schools and libraries. Suburban characteristics also include:

- Heavy reliance on passenger vehicles
- Transit may be present
- Residential areas may consist of single and/or multi-family structures
- Building and structure setbacks from the roadway vary from short to long
- May have well planned and arranged multi-uses that encourage walking and biking

- Planned multi-use clusters may integrate residential and commercial areas along with schools and parks
- Some highways that fit this category may be designated by WSDOT as “Main Street Highways” (see Appendix B: Identification of State Highways as Main Streets, <http://www.wsdot.wa.gov/research/reports/fullreports/733.1.pdf>.)

### 1102.02(1)(c) Urban

Urban locations are high density, consisting principally of multi-story and low to medium rise structures for residential and commercial use. Areas usually exist for light and sometimes heavy industrial use. Many structures accommodate mixed uses: commercial, residential, and parking. Urban areas usually include prominent destinations with specialized structures for entertainment, athletic and social events as well as conference centers and may serve as a Main Street (see [1102.03\(6\)](#)). Urban characteristics also include:

- Various government and public use structures exist that are accessed regularly
- Building setbacks are both short and long
- Streets normally have on-street parking
- Wide sidewalks and plazas accommodate more intense pedestrian traffic
- Bicycle lanes and transit corridors are frequently present
- Off-street parking includes multi-level structures that may be integrated with commercial or residential uses
- Some highways that fit this category may be designated by WSDOT as “Main Street Highways” (see Appendix B: Identification of State Highways as Main Streets)

Due to the differences in developmental scale among urban areas as well as growth demand urban-urban core, context boundaries change over time with the urban core area expanding in high growth situations and possibly contracting in low or no growth situations.

### 1102.02(1)(d) Urban Core

Urban core locations include the highest level of density with its mixed residential and commercial uses accommodated in high-rise structures. There is commonly on-street parking, although it is usually time restricted. Most parking is in multi-level structures attached or integrated with other structures. The area is accessible to automobiles, commercial delivery vehicles, biking, walking, and public transit. Urban Core characteristics also include:

- Sidewalks and pedestrian plazas are present
- Bicycle facilities and transit corridors are common
- Typical land uses are mixed commercial, residential, with some government or similar institutions present
- Commercial uses predominate, including financial and legal
- Structures (predominantly high rises) may have multiple uses
- With the highest land value of any category, setbacks from the street are small
- Some highways that fit this category may be designated by WSDOT as “Main Street Highways” (see Appendix B: Identification of State Highways as Main Streets)

### 1102.03 Transportation Context

This section describes the procedure for determining the current and future transportation context for the roadway. On larger projects, more than one transportation context may apply within project limits. Network connections are also useful in understanding the transportation context.

Each transportation context is to be described in terms of the following categories and considerations:

- Roadway type
- Bicycle route type
- Pedestrian route type
- Freight route type
- Transit use considerations
- Complete streets and Main Street highways

Seek endorsement from the project advisory team (see [Chapter 1100](#)) for determinations of these transportation context types and considerations, including input from local agency (local jurisdictions and transit agencies) and stakeholders. Document determination of each of these transportation contexts for both current and future states in Section 2 of the Basis of Design, and carry these results forward into determination of modal compatibility and modal priority ([Chapter 1103](#)).

Additional information supporting work described in this section is provided on the WSDOT Design Office website.

#### 1102.03(1) Roadway Type

The initial roadway type is defined by the designated functional classification on the WSDOT State Route Log for the route as listed below for non-freeway facilities. A final roadway type determination is based on an assessment of whether a different functional class description (given below) corresponds better to the current and future state of the facility, compared to the designated functional class for the facility. The future state is determined after an assessment of the future modal route types described below. Justify the selection of a final roadway type whether it is the same or different from the designated functional class.

Freeways (including Interstate freeways) are defined in [Chapter 1232](#). These routes typically are limited access facilities. The roadway type for freeways is freeway.

Roadway types for non-freeway facilities are described as follows.

- Principal Arterial – Corridors of regional importance connecting large centers of activity. These routes may be limited access facilities.
- Minor Arterial – Corridors of regional or local importance connecting centers of activity.
- Collector – Roadways of local importance providing connections between arterials and local roads.
- Local – Roads with no regional importance for local circulation and access only

### **1102.03(2) Bicycle Route Type**

Bicycle routes are categorized based on the purpose of the trip and the network connectivity a facility provides. Use quantitative and qualitative information about bicycle connections associated with the project location to determine the current and future bicycle route type using one of these three classifications:

- Citywide Connector (CC) — The route is part of a citywide network, provides a connection to major activity centers, or is a regional bike route stretching over several miles that attracts a high volume of use, serving a primary commute or recreational purpose. These routes are typically associated with arterials and collectors.
- Neighborhood Connector (NC) — The route provides a neighborhood or sub-area connection, making connections to higher order facilities or more local activity centers, such as neighborhood commercial centers. These routes are typically associated with minor arterials and collectors.
- Local Connector (LC) — The route provides local connections of short lengths, providing internal connections within neighborhoods, or linking neighborhoods to higher order facilities. These routes are typically associated with collectors and local roads.

### **1102.03(3) Pedestrian Route Type**

Pedestrian use is described in terms of estimated volumes (current and potential future). The amount of pedestrian traffic impacts several factors, including pedestrian facility capacity, vehicular delays at signalized intersections, and most importantly, the level of risk associated from pedestrians in the travelled way. The four pedestrian route types are based on volume as follows:

- P-1: rare or occasional use
- P-2: low volume – best measured in pedestrians per day
- P-3: medium volume - best measured in pedestrians per hour
- P-4: high volume - best in pedestrians per hour, where sub-hour peak periods are typical

### **1102.03(4) Freight Route Type**

Freight routes may not require significant additional facilities beyond those provided for other motorized vehicles, if mobility and speeds of vehicular routes are consistent with freight movement. Special design consideration is commonly related to the Freight and Goods Transportation System classification. Document the classification for the project area.

Contact Rail, Freight, and Ports Division for help identifying freight classifications, industry needs and truck operations.

Truck route classifications can be found here:

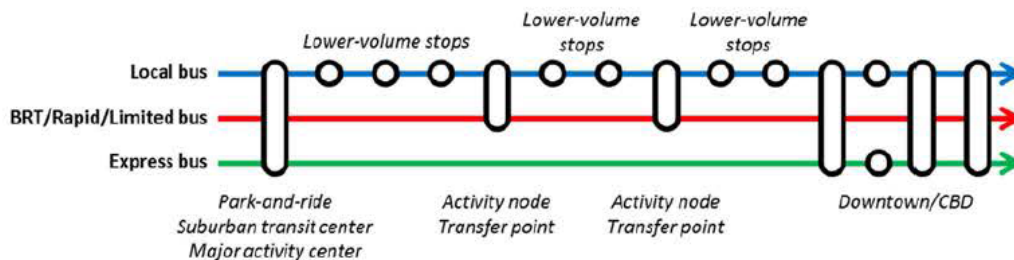
<http://www.wsdot.wa.gov/Freight/EconCorridors.htm>

Additional information: <http://www.wsdot.wa.gov/freight/>

### 1102.03(5) Transit Use Considerations

Transit can provide service on any roadway type. The purposes of transit trips are similar to those of automobile trips and include commuting, work related business, shopping, personal errands, and social/recreational. The facilities and design considerations for transit uses depend on the type of transit service being provided. Note that special design consideration is required for projects that involve one or more of the following elements:

- Fixed route type: there are three primary types of fixed-route transit service, operating along designated routes at set times (Local, Limited, and Express). If one of these services exists on the project, determine the route type using criteria shown in the illustration below and the following bullets:



Source: TRPC Report 165: Transit Capacity and Quality of Service Manual.

- Local routes serve many stops along a route and emphasize access to transit over speed.
- Limited stop routes (also known as frequent routes, including bus rapid transit) balance transit access with speed. These routes run frequently and serve higher volume stops (e.g. major activity centers and transfer points).
- Express routes emphasize speed over transit access, and are often used for longer distance trips.

Note that in addition to fixed-route service, many agencies provide demand-response paratransit services that provide specialized transportation services in both rural and urban areas.

- Bus rapid transit or light rail
- Transit signal priority installation
- Planned transit facilities and routes
- In lane bus stops and/or potential bus pullouts
- Facilities for people with specialized transportation needs (e.g. hospitals, senior centers, schools, transit-dependent communities, etc.)

When evaluating transit needs and the potential for transit to improve highway performance in the project area, document relevant information or data about current transit capacity and quality of service (as defined in the Transit Capacity and Quality of Service Manual) and current and potential future use and travel markets. Include consideration for people walking and biking to/from transit connections. Contact the Public Transportation Division for help or for more information about identifying and coordinating with transit agencies and local jurisdictions that serve the project area (<http://wwwi.wsdot.wa.gov/PubTran/>).

### 1102.03(6) Complete Streets and Main Street Highways

Complete street contexts consider all transportation modes and often require differing modal priorities based on the existing land uses or may even consider multiple modes of equal priority. Complete streets may be desirable in various land use contexts including urban core, urban, suburban, small town, and even some rural contexts.

The Main Streets designation for highways is a point of reference and consideration when documenting transportation context, and should be noted on the Basis of Design. Main Street highways serve the aesthetic, social, economic, and environmental values in a larger community setting in addition to transportation. They are set up as specific state route and milepost designations.

See the *Complete Streets and Main Street Highways Program* document listed in Supporting Information at the end of this chapter for more information. For the list of designated highways see *State Highways as Main Streets: A Study of Community Design and Visioning*, Appendix B: Identification of State Highways as Main Streets,

<http://www.wsdot.wa.gov/research/reports/fullreports/733.1.pdf>.

### 1102.04 Documentation

Document the following in Section 2 of the Basis of Design:

- Land use category
- Roadway type
- Bicycle route type
- Pedestrian route type
- Freight route classification
- Transit use considerations
- Main Streets designation

Describe the process that was followed to reach these designations. If the work involved review and verification of previous work, document that process as well. If characteristics vary within project limits include the milepost ranges to which each of the designations apply.

The Context and Modal Accommodation Report is a template available for use in this documentation process (see <https://www.wsdot.wa.gov/design/support.htm>).



## 1102.05 References

### 1102.05(1) *Federal/State Directives, Laws, and Codes*

[23 Code of Federal Regulations \(CFR\) 450, Subpart B](#), Statewide Transportation Planning

[23 CFR 450, Subpart C](#), Metropolitan Transportation Planning and Programming

[23 United States Code \(USC\) 134](#), Metropolitan Planning

[23 USC 135](#), Statewide Planning

[Revised Code of Washington \(RCW\) 35.58.2795](#), Public transportation systems – Six-year transit plans

[RCW 35.77.010\(2\)](#) and [RCW 36.81.121\(2\)](#), Perpetual advanced six-year plans for coordinated transportation program expenditures – Nonmotorized transportation – Railroad right-of-way

[RCW 36.70A](#), Growth management – Planning by selected counties and cities

[RCW 43.21C](#), State environmental policy

[RCW 47.05](#), Priority programming for highway development

[RCW 47.06](#), Statewide transportation planning

[RCW 47.06B](#), Coordinating special needs transportation

[Secretary's Executive Order 1090](#) – Moving Washington Forward: Practical Solutions

[Secretary's Executive Order 1096](#) – WSDOT 2015-17: Agency Emphasis and Expectations

### 1102.05(2) *Supporting Information*

#### WSDOT References

*Understanding Flexibility in Transportation Design – Washington*, WA-RD 638.1, WSDOT, 2005

<http://www.wsdot.wa.gov/research/reports/600/638.1.htm>

*Complete Streets and Main Street Highways Program*, WSDOT, 2011

<https://www.wsdot.wa.gov/research/reports/fullreports/780.1.pdf>

*State Highways as Main Streets: A Study of Community Design and Visioning*, WSDOT, 2009

**Appendix B: Identification of State Highways as Main Streets**

<http://www.wsdot.wa.gov/research/reports/fullreports/733.1.pdf>

WSDOT Functional Classification map application:

<http://www.wsdot.wa.gov/mapsdata/travel/hpms/functionalclass.htm>

#### Other References

*Complete Streets Planning and Design Guidelines*, North Carolina Department of Transportation, July 2012. [http://www.pedbikeinfo.org/pdf/PlanDesign\\_SamplePlans\\_CS\\_NCDOT2012.pdf](http://www.pedbikeinfo.org/pdf/PlanDesign_SamplePlans_CS_NCDOT2012.pdf)

*Designing Walkable Thoroughfares: A Context Sensitive Approach*, Institute of Transportation Engineers, Washington D.C., 2010

🔗 <http://ecommerce.ite.org/IMIS/ItemDetail?iProductCode=RP-036A-E>

*Evaluating Transportation Land Use Impacts*, Victoria Transport Policy Institute, 2015

🔗 <http://www.vtppi.org/landuse.pdf>

*The Innovative DOT: A Handbook of Policy and Practice*, Smart Growth America, Washington D.C., 2015

🔗 <http://www.smartgrowthamerica.org/the-innovative-dot>

*Land Use and Regional Planning: Achieving Integration Between Transport and Land Use*, European Commission, 2006

🔗 [http://www.transport-research.info/Upload/Documents/200608/20060831\\_102457\\_87241\\_Land\\_use.pdf](http://www.transport-research.info/Upload/Documents/200608/20060831_102457_87241_Land_use.pdf)

*Livability in Transportation Guidebook: Planning Approaches that Promote Livability*, FHWA, 2010

🔗 [http://www.fhwa.dot.gov/livability/case\\_studies/guidebook/](http://www.fhwa.dot.gov/livability/case_studies/guidebook/)

*Measuring Sprawl 2014*, Smart Growth America, Washington D.C., 2014

🔗 <http://www.smartgrowthamerica.org/measuring-sprawl>

*NCHRP Report 855 – An Expanded Functional Classification System for Highways and Streets* [🔗](http://www.trb.org/NCHRP/Blurbs/176004.aspx)

*Small Town and Rural Multimodal Networks* (FHWA-HEP-17-024), December 2016.

🔗 [https://www.fhwa.dot.gov/environment/bicycle\\_pedestrian/publications/small\\_towns/](https://www.fhwa.dot.gov/environment/bicycle_pedestrian/publications/small_towns/)

*Smart Transportation Guidebook*, New Jersey Department of Transportation and Pennsylvania Department of Transportation, 2008.

🔗 <http://www.state.nj.us/transportation/community/mobility/pdf/smarttransportationguidebook2008.pdf>

*Urban Street Design Guide*, National Association of City Transportation Officials, New York, NY, 2013

🔗 <http://nacto.org/>

- 1103.01 General Overview
- 1103.02 Control: Design Year
- 1103.03 Control: Modal Priority
- 1103.04 Control: Access Control
- 1103.05 Control: Design Speed
- 1103.06 Control: Terrain Classification
- 1103.07 Documentation
- 1103.08 References

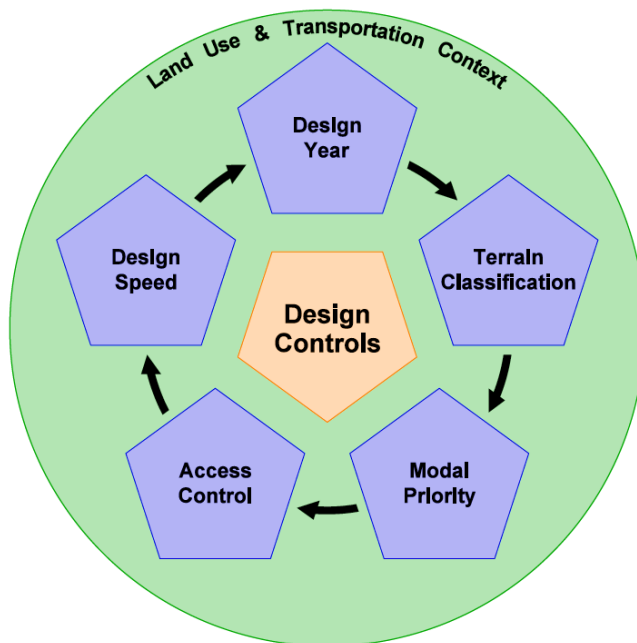
## 1103.01 General Overview

Design controls are specific factors that directly influence the selection of most design elements and their dimensions. Design controls establish fundamental boundaries for design alternatives. Selection of design controls is documented on the Basis of Design. This chapter provides guidance on the selection of design controls for state routes.

The five WSDOT design controls include:

- Design Year
- Modal Priority
- Access Control
- Design Speed
- Terrain Classification

**Exhibit 1103-1 WSDOT Design Controls**



*Reciprocal connections between design controls and land use and transportation contexts*

## 1103.02 Control: Design Year

**Design year** is the forecast year used for design. The year of opening is when the construction will be complete and the project location is fully operational. Design year selection is dependent on a decision to design for the year of opening, or for a future year based on forecast or planned conditions. Design year has historically been associated with a 20-year vehicle traffic forecast used in development of large mobility and capacity expansion projects. This is the origin of the term **horizon year**. Horizon year is typically considered to be 20 years from the year construction is scheduled to begin.

WSDOT policy on design year is intentionally flexible. The design year can be any interim year selected between the project year of opening year and the horizon year. Many lower-cost projects result in immediate performance improvements when construction is completed. Safety projects are an example of this where the basis of design may show design year as the year of opening.

Some projects may require horizon year analysis of an alternative regardless of the selected design year. A project may be required to evaluate alternatives based on the horizon year (20 years from the scheduled beginning of construction) if the project:

- Involves a federal nexus (federal funds involved, involves federal lands, or requires federal approvals or permits)
- Is a Project of Divisional Interest (See [Chapter 300](#))
- Is a new/reconstruction project as defined in [Chapter 300](#)

Contact the region ASDE if there are questions.

## 1103.03 Control: Modal Priority

The concepts and method described in this section are adapted from National Cooperative Highway Research Program Report 855: “*An Expanded Functional Classification System for Highways and Streets*” (see <http://www.trb.org/NCHRP/Blurbs/176004.aspx>)

### 1103.03(1) Design Users

“Design users” refers to the modes that are legally permitted to use a facility. The intent in identifying design users is to highlight all user needs, recognize modal interactions, and develop an integrated system for all users. Identifying the design users is the first step in determining which modes to accommodate and prioritize. On the Basis of Design, list design users with sufficient descriptive detail. Include consideration for all ages and abilities.

Division III of the document *Understanding Flexibility in Transportation Design – Washington* is a key resource for understanding the needs and characteristics of various design users.

### 1103.03(2) Modal Accommodation

Modal accommodation refers to the level to which a travel mode will be addressed in the design. It is expressed on a scale of low, medium, and high, where a higher accommodation level is associated with the use of design features or criteria that tend to improve the performance of that mode compared to a lower level. Once established, the modal accommodation level is used to inform the decision on modal priority (See [1103.03\(3\)](#)). Determine the modal accommodation

level for both the current year (prior to opening) and the design year. These are referred to as existing and future conditions in the guidance that follows. Note that in many cases, the planning documentation, data, or information in the project vicinity may not be available for the project’s design year. In those cases, identify the forecast or horizon year used by the local agency or planning organization in its work and planning products, and document the use of that year as the future year for purposes of determining the modal accommodation level.

1. An **initial** modal accommodation determination, for both the current and design years, are made using [Exhibit 1103-2](#). The initial determination uses the roadway type and land use contexts that were determined earlier and documented in Section 2 of the Basis of Design (See [Chapter 1102](#)).
2. A **final** determination for both the current and design years is made using additional information and evidence to validate or modify the initial determination.

Make the final modal accommodation determination for each mode in consultation with the project advisory team and/or subject matter expert(s), as they may recommend modifications to the initial determinations (see [1100.04](#) for more information about working with the project advisory team). [Exhibit 1103-3](#) provides examples of land-use and transportation characteristics that a project advisory team or subject matter expert(s) may consider in adjusting accommodation up or down for any particular travel mode. These characteristics can represent either the current suitability of a facility to accommodate a mode, or its future strategic role with respect to accommodating that mode. Note that the Context and Modal Accommodation Report provides a template for making and documenting decisions about modal accommodation.

**Exhibit 1103-2 – Initial Modal Accommodation Level**

		Land-Use Context			
		Rural	Suburban	Urban	Urban Core
Roadway Type	Freeways				
	Principal Arterial				
	Minor Arterial				
	Collector				
	Local				

<p><b>Motor Vehicles Incl. Freight</b></p> High Medium Low	<p><b>Bicycles</b></p> High Medium Low	<p><b>Pedestrians</b></p> High Medium Low	Transit compatibility not shown because it varies by route (compatibility can't be determined based on roadway type and land-use context)
--	--	---	---

Additional guidance on the use of the following criteria in determining final modal accommodation level is provided on the Design Support site:

<http://www.wsdot.wa.gov/Design/Support.htm>

### Exhibit 1103-3 Example Characteristics Related to Modal Accommodation

Land Use Characteristic	Increased Modal Accommodation Level
High proximity to activity centers	Pedestrian, Transit, Bicycle
Industrial and commercial land uses in surrounding area	Auto, Freight
High densities of both residential and employment	Bicycle, Pedestrian, Transit
Minimal building setbacks adjacent to roadway	Bicycle, Pedestrian
Human scale architecture present	Bicycle, Pedestrian, Transit
Transportation Characteristic	Increased Modal Accommodation Level
Well-established grid network	Bicycle, Pedestrian, Transit, Auto
T-2 freight route	Auto, Freight
Streetside elements	Bicycle, Pedestrian, Transit
Frequent signalized intersections along route	Auto, Transit, Pedestrian

#### 1103.03(2)(a) Vehicle modal accommodation level

Consider the vehicle modal accommodation level when making design decisions that address or affect needs associated with vehicle travel. Start with the initial modal accommodation level for motor vehicles per [Exhibit 1103-2](#), and adjust it to establish the final level based on documented project specific conditions related to the quality of travel experience, and identified performance targets, that can be influenced by the project design, such as vehicle Level of Service, travel time, access classification, and other factors determined by subject matter experts or the project advisory team.

#### 1103.03(2)(b) Bicycle modal accommodation level

Consider the bicycle modal accommodation level when making design decisions that address or affect needs associated with bicycle travel. Start with the initial modal accommodation level for bicycles per [Exhibit 1103-2](#), and adjust it to establish the final level based on documented project specific conditions related to the quality of travel experience, and identified performance targets, that can be influenced by the project design, such as bicycle route type, efficiency of travel, range, bicyclist safety, route spacing, bicycle volumes, and other factors determined by subject matter experts or the project advisory team.

#### 1103.03(2)(c) Pedestrian modal accommodation level

Consider the pedestrian modal accommodation level when making design decisions that address or affect needs associated with pedestrian travel. Start with the initial modal accommodation level for pedestrians per [Exhibit 1103-2](#), and adjust it to establish the final level based on documented project specific conditions related to the quality of travel experience, and

identified performance targets, that can be influenced by the project design, such as pedestrian route type, efficiency of travel, range, pedestrian safety, block length, and other factors determined by subject matter experts or the project advisory team.

### 1103.03(3) **Modal Priority**

**Accommodate** means that the roadway will be designed so that the chosen modes can use it, while **accommodation level** refers to the extent to which that accommodation may be required. **Priority** refers to the decision to optimize the design based on the performance of one or more travel modes. Modal priority is used as input to choosing the appropriate geometric cross section (see [Chapter 1230](#)).

Modal priority addresses all modes expected to use the facility. Determine modal priority using the accommodation level results, as well as other relevant information about freight, transit, and any other modes considered and documented in the Context and Modal Accommodation Report and Basis of Design. Engage the project advisory team as provided in [Section 1100.04](#).

If the modal priority is inconsistent with assumptions made about the project during a planning or scoping phase, work with program management staff to consider the need for any changes to project scoping documentation, including scope, schedule, and budget.

Document the modal priority on the Basis of Design for both the current and future conditions.

### 1103.03(4) **Intersection Design Vehicle**

WSDOT policy provides flexibility when choosing the intersection design vehicle. The purpose for this policy is to balance user needs and avoid the unnecessary expense of oversizing intersections. Considerations include frequency of the design vehicle and effects on other design users, specifically pedestrian crossing distance and times, and bicycle turning and through movements. Consider providing more protected intersection treatments for pedestrians and bicyclists to mitigate turning conflicts.

An intersection design vehicle is a specific selection made at each intersection leg. Select a design vehicle that allows the largest vehicles commonly encountered to adequately complete a required turning maneuver. The objective is not necessarily to size the specific intersection curb radius (unless there is a baseline need associated with the larger vehicles), but rather to account for a reasonable path to accommodate the large vehicle turning maneuver without conflicts (see [Chapter 1310](#)). Use turn simulation software (such as AutoTURN®) to analyze turning movements.

**Example:** An intersection with a pedestrian modal priority experiences infrequent turning movements by a WB-67. A smaller curb radius would benefit pedestrians due to shorter crossing times and reduced exposure to vehicles. Using turn simulation software, a practicable path for the WB-67 can be identified, even though path intrusion into the second same direction lane or painted median may be necessary. The infrequent use by a WB-67, along with the pedestrian modal priority, validate the decision for selecting a smaller design vehicle for the intersection while accommodating the WB-67 vehicle.

Conversely, if the crossroad was identified as being within a [Freight Economic Corridor](#), with frequent turning movements from larger vehicles, it would be appropriate to size the intersection to prevent the second lane incursion.



Consider origins and destinations of large vehicles to understand their needs at specific intersection locations. Also, consider alternatives that may help lower turning speeds and minimize pedestrian exposure. Work with stakeholders, businesses, and service providers to understand their needs (like transit, school bus and emergency vehicle movements) and define the frequency of use at specific intersections. Municipalities may have established truck routes or restrictions that govern local freight patterns.

### 1103.04 Control: Access Control

Access is a critical component informed by an understanding of the land use and transportation contexts. The type of access control selected (see [Chapter 520](#)) affects accessibility and impacts the types of activities and functions that can occur on a segment. It is important for mobility and economic vitality projects to consider whether the current access classification and/or planned access classification conforms to the context selected for design (see [Chapter 1102](#)).

During development of the state highway system, access management functioned to preserve the safety and efficiency of regional highways. However, the level of access management can also significantly affect accessibility to land uses, modal mobility needs and the economic vitality of a place.

Unless access control has already been acquired by the purchase of access rights, it is necessary to select the appropriate type of limited access control or managed access control during planning and design. Appropriate access control should be considered so as not to hinder bicycle and pedestrian accessibility, mobility, and safety.

A choice to change the current or planned access control is a major decision and is to be consistent with the context, desired performance targets, and modal priorities for a location.

**Example:** The area around a managed access Class 2 route has incurred significant development, increasing the number of local trips on a segment of the route. Over time, additional intersections and access connection permits have been granted. In this situation, it may be appropriate to consider selecting managed access Class 4 or 5 because of the changes in functions and activities along the segment over time.

Conversely, a route may have a need to improve motor vehicle travel time performance, and managed access Class 1 may be appropriate.

If an alteration to current or planned access is determined necessary, consult the Headquarters Access and Hearings Manager for preliminary approval for the selection, and document on the Basis of Design (see [Chapter 1100](#)). For additional information on access control and access management, see [Chapters 520, 530, and 540](#).

### 1103.05 Control: Design Speed

WSDOT uses a target speed approach for determining design speed. The objective of the target speed approach is to establish the design speed at the desired operating speed. The target speed selection is derived from other design controls, as well as transportation and land use context characteristics.

Exhibit 1103-4 shows possible (planning level) target speeds for the various roadway types and land use contexts discussed in [Chapter 1102](#). The target speeds shown in the exhibit are



suggestions only, and the target speed for the specific location may vary from those shown in the exhibit.

#### Exhibit 1103-4 Target Speed Based on Land Use Context and Roadway Type

		Land-Use Context			
		Rural	Suburban	Urban	Urban Core
Roadway Type	Freeways	High	High	High	High
	Principal Arterial	High	Intermediate / High	Low / Intermediate	Low
	Minor Arterial	High	Low/ Intermediate	Low / Intermediate	Low
	Collector	Low/ Intermediate	Low/ Intermediate	Low	Low
	Local	Low/ Intermediate	Low	Low	Low

Engage the public, local agency staff and officials, and transit agencies prior to selecting the target speed. Once the target speed has been selected, it becomes the design speed for the project. The goal of the target speed approach is that the speed ultimately posted on the completed project is the same as the design, and ultimately, the operating speed. In order to achieve this outcome, consider:

- The impact of existing or proposed contextual characteristics
- Modal priorities
- Access control selection
- Performance need(s)
- Contributing factors analyses that have been developed for the project

**Lowering target speed:** When selecting a target speed in excess of the existing posted speed, or where excessive operating speeds were identified from contributing factors analysis of the baseline performance need, consider the use of roadway treatments that will help achieve the selected target speed (see [1103.05\(2\)](#)) during alternatives formulation.

Speed management treatments are used to achieve lower vehicle speeds. When speed management treatments are proposed to accomplish a desired target speed operation concurrence of the Region Traffic Engineer is required. When a design speed is proposed for a project that is lower than the existing posted speed, the approval of the State Traffic Engineer is also required. See [1103.05\(2\)](#) below for more on speed management. Careful consideration of other modal needs should be evaluated before raising target speeds.

**Raising target speed:** When selecting a target speed in excess of the existing posted speed, measures such as greater restriction of access control and segregation of modes may be necessary to reduce conflicts in activities and modal uses. Wider cross sectional elements like lanes and shoulders are used with higher speed facilities.

**Setting the posted speed:** Use caution when basing a target speed on one or more contextual characteristics that are proposed to take place after project opening, as the goal of ending up with a posted speed equal to the design speed at opening may be jeopardized.

The Region Traffic Engineer is responsible for setting the posted speed on the highway once the project is completed. Target speed is only one of the considerations used when establishing posted speed. Engage and include the Region Traffic Engineer and Traffic Office staff in key decision-making that will affect the target, design, and operating speed selection. Incorporate consideration of traffic calming measures as needed.

### **1103.05(1) Low, Intermediate, and High Speeds**

To provide a general basis of reference between target speed and geometric design, WSDOT policy provides three classifications of target speed as follows:

1. **Low Speed is 35 mph and below.** A low target speed is ideal for roadways with pedestrian and bicycle modal priorities. Locations that include frequent transit stops, intermodal connections, moderate to high intersection density, or moderate to high access densities may also benefit from lower speed environments. Low speed facilities in urban areas typically use narrower cross section elements.
2. **Intermediate Speeds are 40 mph and 45 mph.** An intermediate target speed is ideal for speed transitions between high and low target speed environments. Locations with low access densities and few at-grade intersections are also examples of where intermediate speed may be appropriate. In these locations consider a higher degree of separation between motor vehicles and bicycles and pedestrians.
3. **High Speed is 50 mph and above.** A high target speed is ideal for motor vehicle oriented roadways such as freeways and highways, often serving regional or longer-distance local trips. Rural connector roadways with infrequent farm or residential accesses are also consistent with the use of high target speeds. In high target speed locations consider the highest degree of separation between motor vehicles and bicycles and pedestrians. Highways with high speeds are associated with wider cross section elements.

### **1103.05(2) Speed Management**

Speed management is necessary within many highways to achieve an optimal multimodal facility that will support the land use and transportation contexts. Speed management may also be necessary to maintain consistent or desired speeds between adjacent roadway segments. Identify speed transition segment(s) as necessary to achieve desired speeds. Identify potential speed transition segments when scoping the project.

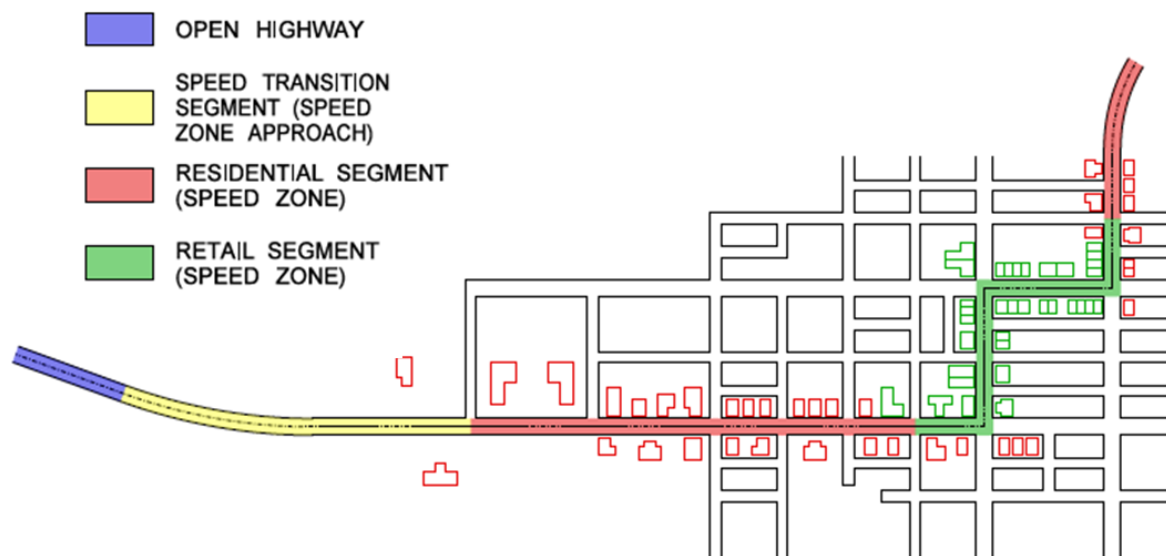
#### **1103.05(2)(a) Speed Transition Segments**

Include a speed transition segment where there is a need to obtain a target speed lower than the existing operating speed. A speed transition segment is not needed where existing operating speeds are within 5 mph of the target speed for a given location. The transition segment may not always directly precede the speed zone segment as shown in [Exhibit 1103-5](#).

Example: A residential segment could benefit from introducing a speed transition segment farther upstream to increase the likelihood that approaching vehicles operate at the desired speed, for both segments.

The speed transition segment may incorporate a variety of treatments that alert motorists to a changing roadway environment. These treatments are intended to narrow driver focus and/or affect driver decision-making on that segment. Consider the transition segment location and length when providing multiple treatments in a short distance.

## Exhibit 1103-5 Speed Transition Segment Example

**1103.05(2)(b) Speed Reduction Traffic Calming Treatments**

Traffic calming treatments can serve a variety of purposes, from deterring higher volumes of motorized traffic to providing speed management. This section presents traffic calming treatment options to increase the reliability of reducing vehicular speed. Speed reduction traffic calming treatments applied independently or in combination may be beneficial depending on the type and use of the treatments. Many speed management treatments have demonstrated varied effectiveness for single applications. Multiple treatments in series and parallel that build upon the context characteristics are more effective. Contact the Headquarters Design and Traffic offices for any project implementing a speed transition segment, for assistance on selection and monitoring of treatments.

Speed management techniques vary and have different results depending on the speed and types of users at a given location. The following subsections present different options for speed-reducing traffic calming treatments.

**1103.05(2)(b)(1) Geometric Treatments**

Geometric treatments can include overall changes of the horizontal or vertical geometry to introduce features that will support maintaining the targeted speed. [Exhibit 1103-6](#) shows geometric traffic calming treatments and potential considerations when selecting these types of treatments.

**1103.05(2)(b)(2) Roadside and Pavement Treatments**

There are a number of treatments that create an environment that influences human factors and perception. Many successful roadside treatments use landscaping in an attempt to achieve the desired behavioral effect. It is important to coordinate with project partners to evaluate landscaping features and provide for traveled way operations and sight lines. The introduction of roadside features like trees, parking, and/or bicycle lanes to alert travelers to a change in conditions may be appropriate. Applying features like vegetated medians or trees is appropriate at some locations and contexts. In landscaping discussions, include Traffic Engineers,

Maintenance, Urban Forestry, Landscape Architects, and Human Factors and Safety Experts. If the landscaping proposed is in a managed access segment with local jurisdiction responsibility for the roadside, coordinate to understand the jurisdictions' capabilities to sustain the landscaping and that it meets their clear zone goals.

Pavement-related treatments can also produce undesirable impacts on other users. For pavement-related treatments, include Materials Engineers, Maintenance, Traffic, and ADA Compliance Experts to review what sustainable and effective treatments can be employed.

[Exhibit 1103-7](#) lists roadside and pavement-related traffic calming treatments and considerations to evaluate.

## Exhibit 1103-6 Geometric Traffic Calming Treatments and Considerations

Treatment	Considerations
<b>Taper for Narrow Lanes</b>	Narrowing the lane width can be achieved by restriping lane lines. A decision to taper in or out may depend on other treatments planned, such as introducing a median or chicanes. Base taper rates on the target speed entering the context or speed transition segment, as appropriate. It is recommended that this be the first treatment employed.
<b>Chicanes/Lane Shifts</b>	This treatment may be achieved with curbed features, like planter strips or striping combined with additional fixed delineators. These treatment types are more appropriate when reducing speeds from an initial intermediate speed or less. When introducing this treatment with initial high speeds, the treatment should utilize paint striping, in addition to using other treatments preceding the chicane/lane shift, rather than constructing hardscape features.
<b>Pinch Points</b>	Applies on intermediate to low target speed situations unless completed with striping or other pavement markings. This treatment uses striping, roadside features, or curb extensions to temporarily narrow the vehicle lane. It is likely more appropriate for maintaining a desired target speed within a segment than as part of a speed transition segment. Pinch points are not appropriate for high-speed segments. Use of pinch-point treatments on intermediate speed segments requires concurrence from the Region Traffic Engineer.
<b>Speed Cushion/Humps/Tables</b>	On state highways, this treatment will likely have limited application, but should not be excluded from consideration. Impacts to freight, transit, and emergency service vehicles need to be evaluated prior to selecting these vertical types of treatments. These treatments may only be used when maintaining a 25 mph target speed within a segment.
<b>Raised Intersections</b>	Raised intersections, similar to other vertical treatments, will have limited application on state highways. This treatment typically has higher costs to construct due to the pavement needs. This treatment may be a good option when a roundabout cannot be accommodated at a narrow intersection. It can also be considered where there is a need to improve visibility of the intersection and modal conflicts, especially at problematic stop control intersections planned to remain in place. This treatment may only be used when maintaining a 25 mph target speed within a segment.
<b>Roundabouts</b>	Roundabouts can be a unique feature, providing reduced <u>fatal and serious injury crash</u> potential, traffic calming, and gateway functions (See <a href="#">Chapter 1320</a> and the Roadside Policy Manual for details on roundabout design). Roundabouts are effective from a collision reduction and operational perspective, and they provide reduced driver workload, lower speeds, and limited conflict points. They can assist with access management or when turning movements are limited or restricted on a segment. To determine if a roundabout is appropriate at a specific location, follow the <u>Intersection Control Evaluation</u> process described in <a href="#">Chapter 1300</a> .

## Exhibit 1103-7 Roadside, Streetside, and Pavement-Oriented Traffic Calming Treatments

Treatment	Considerations
<b>Landscaping</b>	Landscaping can be used in conjunction with other treatments to reinforce the surrounding context and the driver's perception of the context. It can also provide width for modal separation. Annual maintenance impacts need to be considered, weighed, and documented prior to selecting types of vegetation to be included.
<b>Raised Vegetated Medians</b>	Introduce a raised vegetated median following other treatments that prepare the driver for this feature. Appropriate for low to intermediate target speed locations and transition segments.
<b>Transverse Rumble Strips</b>	These in-lane rumble strips are intended to alert drivers to a condition change. They are likely placed in conjunction with and prior to traffic signing revisions or in advance of other speed-reducing traffic calming treatments. Appropriate for high, intermediate, or low target speed locations and transition segments.
<b>Optical Speed Markings</b>	This treatment is intended to influence a driver's perception. The treatment consists of 8-inch transverse paint strips within the vehicular lane extending from lane and edge markings (or curb). The striping intervals sequentially decrease, providing the perception of increasing speed, an indication to drivers to slow their operating speed. Optical Speed Markings are ideal for speed transition segments, and are recommended to be applied in conjunction with lane narrowing for high or intermediate target speed locations.
<b>Dynamic Warning Systems</b>	This treatment consists of actively alerting motorists about their operating speed. There are many different systems that accomplish this, including portable radar trailers and post-mounted systems. These can be either permanent or temporary installations. Appropriate for all speeds.
<b>Gateways</b>	The intent of a gateway feature is to alert travelers to a context change. A gateway feature is typically found on the edge of cities or towns, but can be used to highlight specific segments within cities or towns. The gateway can be anything from a banner/structure spanning the facility, to artistic work, landscaping, and/or a roundabout at the first intersection approaching a defined environment context. The gateway feature should be developed by the community. It may be of interest to design a gateway feature fitting the cultural and historic character of the location. Consideration for potential fixed object collisions is an important aspect of gateway design. Gateway features that span or are placed within state right of way will need specific approvals, as identified in <a href="#">Chapter 950</a> . Appropriate for low to intermediate target speed locations and transition segments.

## 1103.06 Control: Terrain Classification

Terrain may limit operational and safety performance for particular modes. While terrain impacts may be addressed at specific locations, it is not cost beneficial to modify terrain continually throughout a corridor. The type of terrain, context, and speed influence the potential operating conditions of the highway, and should be a consideration when selecting mobility performance targets (See [Chapter 1101](#)). For more information on grades, see [Chapter 1220](#).

To provide a general reference between terrain and geometric design, three classifications of terrain have been established:

1. **Level:** Level to moderately rolling, this terrain offers few or no obstacles to the construction of a highway having continuously unrestricted horizontal and vertical alignment.
2. **Rolling:** Hills and foothills, with slopes that rise and fall gently; however, occasional steep slopes might offer some restriction to horizontal and vertical alignment.
3. **Mountainous:** Rugged foothills; high, steep drainage divides; and mountain ranges.

Designate terrain as it pertains to the general character along the alignment of a corridor. Roadways in valleys or passes in mountainous areas might have the characteristics of roads traversing level or rolling terrain and are usually classified as level or rolling, rather than mountainous. See the *Highway Log* for terrain classification.

## 1103.07 Documentation

Document selections for design controls in Section 3 of the Basis of Design.

## 1103.08 References

### 1103.08(1) Federal/State Directives, Laws, and Codes

[Secretary's Executive Order 1090](#) – Moving Washington Forward: Practical Solutions

[Secretary's Executive Order 1096](#) – WSDOT 2015-17: Agency Emphasis and Expectations

### 1103.08(2) Supporting Information

**Design Support website** to download the Basis of Design and Context and Modal Accommodation Report: <http://www.wsdot.wa.gov/Design/Support.htm>

*Designing Walkable Thoroughfares: A Context Sensitive Approach*, Institute of Transportation Engineers, Washington D.C., 2010 [www.ite.org](http://www.ite.org)

*A Policy on Geometric Design of Highways and Streets* (Green Book), AASHTO, Washington, D.C., Current Edition [www.transportation.org/Pages/Default.aspx](http://www.transportation.org/Pages/Default.aspx)

*Urban Street Design Guide*, National Association of City Transportation Officials, New York, NY, 2013 [www.nacto.org](http://www.nacto.org)

*Understanding Flexibility in Transportation Design – Washington*, WA-RD 638.1, Washington State Department of Transportation, 2005  
[www.wsdot.wa.gov/research/reports/fullreports/638.1.pdf](http://www.wsdot.wa.gov/research/reports/fullreports/638.1.pdf)

*NCHRP Report 613 – Guidelines for Selection of Speed Reduction Treatments at High Speed Intersections*, Transportation Research Board, Washington D.C., 2008

🔗 [http://onlinepubs.trb.org/onlinepubs/nchrp/nchrp\\_rpt\\_613.pdf](http://onlinepubs.trb.org/onlinepubs/nchrp/nchrp_rpt_613.pdf)

*NCHRP Report 737 – Design Guidance for High-Speed to Low Speed Transition Zones for Rural Highways*, Transportation Research Board, Washington D.C., 2012

🔗 [http://onlinepubs.trb.org/onlinepubs/nchrp/nchrp\\_rpt\\_737.pdf](http://onlinepubs.trb.org/onlinepubs/nchrp/nchrp_rpt_737.pdf)

*NCHRP Report 600 – Human Factors Guidelines for Road Systems*, 2nd Edition, Transportation Research Board, Washington D.C., 2012

🔗 [http://onlinepubs.trb.org/onlinepubs/nchrp/nchrp\\_rpt\\_600Second.pdf](http://onlinepubs.trb.org/onlinepubs/nchrp/nchrp_rpt_600Second.pdf)

*NCHRP Report 855 – An Expanded Functional Classification System for Highways and Streets*

🔗 <http://www.trb.org/NCHRP/Blurbs/176004.aspx>

*NCHRP Synthesis 443 – Practical Highway Design Solutions*, Transportation Research Board, Washington D.C., 2012

🔗 [http://onlinepubs.trb.org/onlinepubs/nchrp/nchrp\\_syn\\_443.pdf](http://onlinepubs.trb.org/onlinepubs/nchrp/nchrp_syn_443.pdf)

*Measuring Sprawl 2014*, Smart Growth America, Washington D.C., 2014

🔗 <http://www.smartgrowthamerica.org/measuring-sprawl>



- 1120.01 General
- 1120.02 Structures Preservation (P2) and Other Facilities (P3)
- 1120.03 Roadway Preservation (P1)

## 1120.01 General

This chapter provides information specific to preservation project types.

This chapter identifies those elements and features to be evaluated and potentially addressed during the course of a preservation project. The elements listed here may be in addition to the project need identified in the Project Summary or Basis of Design (see [1120.03\(8\)](#)). Preservation projects may also provide opportunities for project partnering and retrofit options involving additional elements (for example see [1231.06](#)).

Preservation projects are funded in three sub-program areas:

- **Roadway Preservation (P1) projects** preserve pavement structure, extend pavement service life, and restore the roadway for reasonably safe operations of the travel modes accommodated by the facility.
- **Structures Preservation (P2) projects** preserve the state's bridge network through cost-effective actions. There are numerous types of bridge preservation actions including: deck rehabilitation, seismic retrofit, painting steel bridges, scour repair, and others.
- **Other Facilities (P3) projects** preserve the function of guardrail and signing, major drainage, major electrical, unstable slopes and other assets.

For more information on these programs see the Planning & Programming – Scoping website:  
<http://wwwi.wsdot.wa.gov/Planning/CPDMO/PlanProgScoping.htm>

## 1120.02 Structures Preservation (P2) and Other Facilities (P3)

For Structures Preservation (P2) and Other Facilities (P3) projects see the scoping instructions specific to the sub-program and type of work to determine the likely design elements to be addressed by the project.

See [Chapter 300](#) for documentation requirements. If the project changes a geometric design element, replaces an existing bridge or installs a new bridge additional documentation may be required; contact your ASDE to discuss appropriate documentation.

## 1120.03 Roadway Preservation (P1)

This section applies to features and design elements to be addressed on Roadway Preservation (P1) projects. See [1120.03\(8\)](#) for instructions on using the Basis of Design to document design elements that are changed by the project.

### **1120.03(1) Adjust existing features**

- Adjust existing features such as monuments, catch basins, and access covers that are affected by resurfacing.
- Evaluate drainage grates and gutter pans, and adjust or replace as needed to address bicycle safety (see Drainage Grates and Manhole Covers in [Chapter 1520](#)).
- For guidance on existing curb see [Chapter 1239](#).
- Replace rumble strips if they are removed through project actions, or if their average depth is less than 3/8", unless there is a documented justification for their removal (see [Chapter 1600](#)).

### **1120.03(2) ADA requirements**

- Address ADA requirements according to WSDOT policy (see [Chapter 1510](#) and any active project delivery memorandums or design memorandums).

### **1120.03(3) Cross slope lane**

- Rebuild the cross slope to a minimum 1.5% when the existing cross slope is flatter than 1.5% and the steeper slope is needed to provide adequate highway runoff. See [Chapter 1250](#) for more information about cross slope.

### **1120.03(4) Cross slope shoulder**

- When rebuilding the lane cross slope, evaluate shoulder cross slope in accordance with [Chapter 1250](#).

### **1120.03(5) Vertical clearance**

- Paving projects, and seismic retrofit projects, may impact vertical clearances (see [Chapter 720](#) for bridge clearances and [Chapter 1020](#) for overhead sign assemblies.)
- If vertical clearance will be changed by the project, evaluate this in accordance with [Chapter 720](#). Include this design element and any other affected geometrics in the Basis of Design, the Design Parameters sheets and the Design Documentation Package.
- Contact the Commercial Vehicle Services Office when changes to vertical clearance are planned.

### **1120.03(6) Delineation**

- Install and replace delineation in accordance with [Chapter 1030](#) (this includes pavement markings, guideposts, and barrier delineation).

### **1120.03(7) Barriers and terminals**

- When the project will affect the elevation of the pavement adjacent to a guardrail, terminal, and transition, measure the height of those systems within the project limit and adjacent to pavement edges, curbs, or sidewalks prior to construction. Measure the height to the top of the rail element from the outside paved shoulder edge when no curb is present, from the gutter line when guardrail is set above a curb, or from the

sidewalk elevation if set behind a sidewalk. Note that for purposes of this guidance, chip seal applications have been determined to not affect barrier height.

- When the height of Type 1 guardrail, terminals, and/or transitions is found to be between 26.5" and 30" prior to construction, and that height is changed such that it is outside of that range following construction, either adjust to a height of 28" minimum to 30" maximum, or replace with a Type 31 system.
- When the height of Type 31 guardrail, terminals, and/or transitions is found to be between 28" and 32" prior to construction, and that height is changed such that it is outside of that range following construction, then adjust the height to 31".
- When guardrail height measurements fall outside the ranges provided in the previous two bullets prior to construction, contact region Program Management for instructions.
- Replace both Breakaway Cable Terminals (BCT) and Type 1 anchors with crashworthy terminals in the following situations: 1) when they are on the upstream end with respect to the closest travel lane and located inside the Design Clear Zone for that closest travel lane, or 2) when they are on the downstream end with respect to the closest travel lane and located inside the Design Clear Zone for the opposing traffic direction.
- Evaluate the guardrail length of need in accordance with [Chapter 1610](#) for runs that need to be raised. Do not exceed 250 feet of additional run length within each guardrail run in Pavement Preservation (P1) projects.
- Note that removal is an option if guardrail is no longer needed based on the guidance in Chapters [1600](#) and [1610](#). Document the location of removal and the reasoning for removal in the Design Documentation Package.
- When adjusting terminals that are equipped with CRT posts, the top-drilled holes in the posts need to be at the surface of the ground.
- Pre-cast concrete barrier sections (either New Jersey or "F" shape) are normally installed at a 32" height, which includes provision for up to a 3" overlay. A 29" minimum height for this type of barrier must be maintained following an overlay.
- Single slope concrete barrier may be pre-cast or cast in place, and is installed new at a height of 42", 48", or 54". A 30" minimum height must be maintained for this type of barrier following an overlay.

### **1120.03(8) Documentation**

For Roadway Preservation (P1) projects, use the Basis of Design to document decisions when the project changes any design elements that are not listed in [1120.03\(1\)](#) through [1120.03\(7\)](#). Document any changes to dimensions on the Design Parameter Sheets.



road approach foreslopes. Where possible, move the crossroad or road approach drainage away from the main line. This can locate the pipe outside the Design Clear Zone and reduce the length of pipe.

Provide slope treatment as shown in the [Standard Plans](#) at the top of roadway cut slopes except for cuts in solid rock. Unless Class B slope treatment is called for, Class A slope treatment is used. Call for Class B slope treatment where space is limited, such as where right of way is restricted.

### 1239.03(1) Drainage Ditches

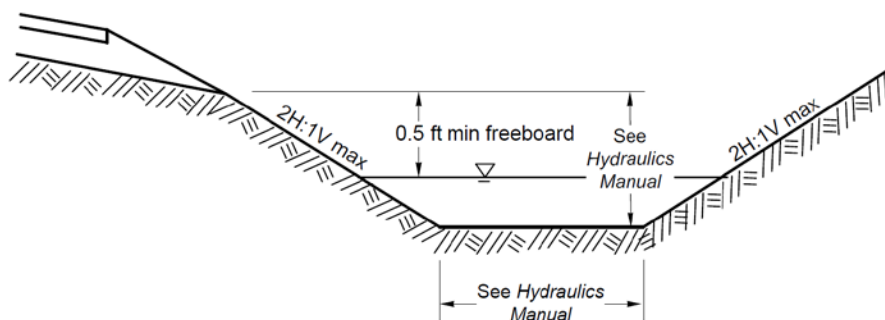
[Exhibit 1239-4](#) provides general information regarding drainage ditch design. The preferred cross section of a ditch is trapezoidal as shown. A 'V' ditch can be used where constraints, such as limited right of way or sensitive areas, preclude a trapezoidal ditch. Ensure hydraulic design requirements are met.

Where a drainage ditch is located adjacent to the toe of a side slope, consider the stability of the foreslope and backslope. A drainage ditch placed immediately adjacent to the toe of side slopes has the effect of increasing the height of the side slope by the depth of the ditch. In cases where the foundation soil is weak, the extra height could result in a side slope failure. As a general rule, the weaker the foundation and the higher the side slopes, the farther the ditch should be from the toe of slope. Consult the Region Materials Engineer for the proper ditch location.

When topographic restrictions exist, consider an enclosed drainage system with appropriate inlets and outlets.

Maintenance operations are also facilitated by adequate width between the toe of the slope and an adjacent drainage ditch. Where this type of facility is anticipated, provide sufficient right of way for access to the facility and place the drainage ditch near the right of way line.

**Exhibit 1239-4 Drainage Ditch Details**



#### Notes:

- Freeboard is the vertical distance from the bottom of base course to the 10-year storm water surface (see the Hydraulics Manual for more information.)
- Coordinate ditch design with region Hydraulics
- See other sections of this chapter for shoulder and side slope details. [1239.03\(2\)](#) Bridge End Slopes

**1239.03(2) Bridge End Slopes**

Bridge end slopes are determined by several factors, including context, fill height, depth of cut, soil stability, and horizontal and vertical alignment. Coordinate bridge end slope treatment with the HQ Bridge and Structures Office (see [Chapter 720](#)). Whenever possible, design to avoid creating environments that might be desirable to the homeless, both for their safety and the safety of maintenance staff.

Early in the bridge plan development, determine preliminary bridge geometrics, end slope rates, and toe of slope treatments. Exhibit 1239-5a provides guidelines for use of slope rates and toe of slope treatments for overcrossings. Exhibit 1239-5b shows toe of slope treatments to be used on the various toe conditions.

**Exhibit 1239-5a Bridge End Slopes**

Bridge End Condition	Toe of Slope End Slope Rate		Lower Roadway Treatment [1]		Slope Rate
	Height	Rate	Posted speed of lower roadway	Treatment	
End Piers on Fill	≤ 35 ft	1¾H:1V	> 50 mph	Rounding	
	> 35 ft	2H:1V [2]	≤ 50 mph	No rounding	
End Piers in Cut	Match lower roadway slope [3]		No rounding, toe at centerline of the lower roadway ditch.		[4]
Lower Roadway in Cut	Match lower roadway slope [3]		No rounding, toe at centerline of the lower roadway ditch.		[4]
Ends in Partial Cut and Fill	When the cut depth is > 5 ft and length is > 100 ft, match cut slope of the lower roadway		When the cut depth is > 5 ft and length is > 100 ft, no rounding, toe at centerline of the lower roadway ditch		[4]
	When the cut depth is ≤ 5 ft or the length is ≤ 100 ft, it is designer's choice		When the cut depth is ≤ 5 ft or the length is ≤ 100 ft, it is designer's choice		[4]

**Notes:**

- [1] See Exhibit 1239-5b.  
 [2] Slope may be 1¾H:1V in special cases.  
 [3] In interchange areas, continuity may require variations.  
 [4] See 1239.03.

- 1300.01 General
- 1300.02 Intersection Control Objectives
- 1300.03 Common Types of Intersection Control
- 1300.04 Modal Considerations
- 1300.05 Procedures
- 1300.06 Documentation
- 1300.07 References

## 1300.01 General

It is WSDOT practice to analyze potential intersection solutions at all intersection improvement locations in accordance with [E 1082 – Business Practices for Moving Washington](#) and [E 1090 – Moving Washington Forward: Practical Solutions](#). The objective is to provide the optimum solution within available resources, with an emphasis on low-cost investments. The analysis can be done for individual intersections, or on a corridor or network basis. This chapter provides guidance on preliminary intersection analysis and selection of control type. Intersection design is completed using [Chapter 1310](#) for the geometrics of intersections, [Chapter 1320](#) for roundabouts, and [Chapter 1330](#) for traffic signals. Use the aforementioned chapters in conjunction with chapters [1106](#), [1230](#) series, [1430](#), [1510](#), and [1520](#) to assist with dimensioning design elements.

Consider design users and the balance between modes, safety and mobility performance considerations, context-sensitive/sustainable design, and economics when selecting and evaluating alternatives to meet the needs of the project.

Identification of intersection projects can come from a variety of programs and sources, including those funded by local agencies and developers. The intent of this chapter is that the procedures apply to all types of intersection modifications on the state highway system. Potential safety project locations are identified through the safety priority programming process. Other programs may identify intersection needs through the priority programming process, but the influence of the type of intersection control with respect to specific performance category needs may not be fully understood until contributing factors analysis is completed (see [Chapter 1101](#)).

Complete an Intersection Control Evaluation (ICE), formerly known as Intersection Control Analysis (ICA), as early as practicable, taking into account the level of community engagement that may need to occur prior to approval. The ICE (see [1300.05](#) for procedures) should be considered a working document that is initiated no later than the scoping phase so that the scope and schedule are compatible with the chosen intersection type. ***Scale the ICE according to the size and complexity of the project***; for example, evaluation of adding a turn lane to an existing intersection control may take less effort than evaluating new intersection control. Consult the region or HQ Traffic offices for assistance with the level of effort required.

It is WSDOT policy to focus on lower cost solutions with the intent to optimize return on investment. Only when all at-grade intersection alternatives are ruled out, including turn restrictions and complete intersection removal, should other more-costly measures be considered, such as grade-separation. Ramp terminal intersections are subject to the analysis requirements of this chapter. See chapters [1360](#) and [550](#) for additional information.

For additional information, see the following chapters:

Chapter	Subject
<a href="#">320</a>	Traffic analysis
<a href="#">321</a>	Sustainable Safety Analysis
<a href="#">530</a>	Limited access control
<a href="#">540</a>	Managed access control
<a href="#">550</a>	<u>Access Revision</u> Report
<a href="#">1100</a>	Practical Design
<a href="#">1101</a>	Need Identification
<a href="#">1103</a>	Design Controls
<a href="#">1106</a>	Design Element Dimensioning
<a href="#">1230</a>	Geometric Cross Section Basics; and other 1230 series chapters
<a href="#">1310</a>	Intersections
<a href="#">1320</a>	Roundabouts
<a href="#">1330</a>	Traffic signals
<a href="#">1340</a>	Driveways
<a href="#">1360</a>	Interchanges
<a href="#">1510</a>	Pedestrian facilities
<a href="#">1515</a>	Shared-use paths
<a href="#">1520</a>	Bicycle facilities

## 1300.02 Intersection Control Objectives

Intersections are an important part of highway design. Intersection control choice requires consideration of all potential users of the facility, including drivers of motorcycles, passenger cars, heavy vehicles of different classifications, public transit, and bicyclists and pedestrians.

Design users have varying skills and abilities. Younger and older drivers in particular are subject to a variety of behavioral or human factors that can influence elements of their driving ability. See NCHRP Report 600 – Human Factors Guidelines for Road Systems: Second Edition for additional information (<http://www.trb.org/Main/Blurbs/167909.aspx>). Bicyclists, from recreational to commuters, also have a variety of skill sets that can influence the effectiveness of bike facilities and intersection operational design (see [Chapter 1520](#) for additional information). Meeting the needs of one user group can directly influence the service that other groups experience. The selection process evaluates these competing needs and results in an optimal balance of tradeoffs for all design users, recognizing the context and priorities of the location.

The intent of an ICE is not to design an intersection, but to evaluate the compatibility of different intersection control types with respect to context, modal priority, intersection design vehicle, and the identified balance of performance needs. Four basic intersection design consideration categories are shown in [Exhibit 1300-1](#) and can affect the intersection control types depending on the situation.

The objectives of the ICE are to:

- Provide a consistent framework to determine the most compatible intersection control type for the location, context, economics, and balance of performance needs.
- Evaluate the operational and safety performance for various appropriate and feasible intersection control types under consideration.



- Evaluate the modal performance considerations between different intersection control types with respect to the identified modal priority and intersection design vehicle (see [Chapter 1103](#)). Identify the potential modal treatments that augment the control types.
- Consider the intersection operations and the relationship with adjacent intersections and other access points.
- Evaluate the intersection control types for potential sustainability, community value, and expected maintenance and operation needs.
- Include roundabouts in all intersection control evaluations due to their safety, operational, and sustainability benefits.
- Consider emerging alternative intersection designs such as displaced left-turn (DLT) and restricted crossing u-turn intersections (RCUT) where appropriate.
- Select the intersection control type for the project based on overall need and context.

## Exhibit 1300-1 Intersection Design Considerations

<b>Human Factors</b>	
<ul style="list-style-type: none"> <li>• Driving habits</li> <li>• Driver workload</li> <li>• Driver expectancy</li> <li>• Driver error</li> <li>• Driver distractions</li> <li>• Perception-reaction time</li> </ul>	<ul style="list-style-type: none"> <li>• Conformance to natural paths of movement</li> <li>• Pedestrian use and habits</li> <li>• Bicycle traffic use and habits</li> <li>• Visual recognition of roadway cues</li> <li>• Compatibility with context characteristics</li> <li>• Demand for alternative mode choices</li> </ul>
<b>Traffic Considerations</b>	
<ul style="list-style-type: none"> <li>• Design users, modal priority, and intersection design vehicle</li> <li>• Design and actual capacities</li> <li>• Design-hour turning movements</li> <li>• Variety of movements (diverging/merging/weaving/crossing)</li> </ul>	<ul style="list-style-type: none"> <li>• Vehicle size and operating characteristics</li> <li>• Vehicle speeds</li> <li>• Transit involvement</li> <li>• Crash Experience</li> <li>• Bicycle movements</li> <li>• Pedestrian movements</li> </ul>
<b>Physical Elements</b>	
<ul style="list-style-type: none"> <li>• Character and use of abutting property</li> <li>• Vertical alignments at the intersection</li> <li>• Sight distance</li> <li>• Angle of the intersection</li> <li>• Conflict areas</li> <li>• Speed-change lanes</li> <li>• Managed lanes (HOV, HOT, shoulder)</li> <li>• Accessible facilities</li> <li>• Parking zones</li> <li>• Geometric design features</li> </ul>	<ul style="list-style-type: none"> <li>• Traffic control devices</li> <li>• Illumination</li> <li>• Roadside design features</li> <li>• Environmental factors</li> <li>• Crosswalks</li> <li>• Transit facilities</li> <li>• Driveways</li> <li>• Streetside design features</li> <li>• Adjacent at-grade rail crossing</li> <li>• Access management treatments including turn restrictions</li> </ul>
<b>Economic Factors</b>	
<ul style="list-style-type: none"> <li>• Cost of improvements, annual maintenance, operations and life cycle costs, and salvage value</li> <li>• Effects of controlling access and right of way on abutting properties where channelization restricts or prohibits vehicular movements</li> <li>• Energy consumption and emissions</li> </ul>	

## 1300.03 Common Types of Intersection Control

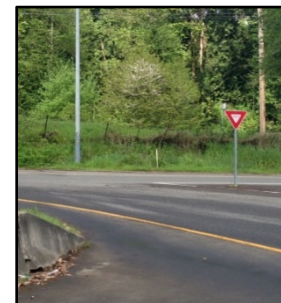
### 1300.03(1) Uncontrolled Intersections

- Uncontrolled intersections do not have signing, and the normal right of way rule ([RCW 46.61.180](#)) applies.
- This intersection type is typically found on local roads and streets where the volumes of the intersecting roadways are low and roughly equal, speeds are low, and there is little to no crash history.
- Uncontrolled intersections are not recommended for state routes.



### 1300.03(2) Yield Control

- Intersections with yield control assign right of way without requiring a stop.
- Mostly used at rural low-volume ramps and wye (Y) intersections.
- Yield control is generally not recommended in urban locations or where pedestrians are expected.



### 1300.03(3) Two-Way Stop Control

- Intersections with two-way stop control are a common, lower cost control, which require the traffic on the minor roadway to stop and yield to mainline traffic before entering the major roadway.
- Along certain corridors, especially where u-turn opportunities exist, consider limiting access at two-way stops to “right-in, right-out only.”

### 1300.03(4) Multi-Way Stop Control

- Multi-way stop control normally requires all traffic to stop before entering the intersection.
- Fewer fatal and injury crashes than two-way stop control.
- Multi-way stop control is suited for lower speed facilities with approximately equal volumes on all legs and total entering volumes not exceeding 1,400 vehicles during the peak hour.
- Increased traffic delays, fuel consumption, and air pollution.
- Multi-way stop control is not recommended on multilane state routes or at intersections with unbalanced directional traffic flows because of the delays and queues introduced on the major-volume legs of the intersection.



### 1300.03(5) Roundabouts

Roundabouts are often circular (or near-circular) at-grade intersections, where traffic on the approaches yield to traffic within the circulating roadway. Roundabouts are an effective intersection type that may offer the following:

- Reduced fatal and injury crashes compared with other at-grade intersection types.
- Fewer conflict points.
- Lower potential for wrong-way driving.
- Reduced traffic delays.
- Traffic-calming and lower speeds.
- More capacity than a two-way or multi-way stop.
- Quickly serves pedestrians needing to cross the intersection and shortens crossing distance for pedestrians by allowing for crossing in stages using splitter islands as pedestrian refuges.
- Reduced vehicular approach speeds that result in reduced crash and severity potential to pedestrians.
- Ability to serve high turning volumes with minimal number of approach lanes.
- Improved operations where space for queuing is limited.
- Improved capacity at ramp terminal intersections with high left-turn volumes without affecting the structure.
- Facilitation of u-turn movements and can be appropriate when combined with access management along a corridor.
- Aesthetic treatments and gateways to communities.
- Flexibility to fit funding and a variety of site constraints. Roundabouts are scalable and site-specific solutions. See [Chapter 1320](#) for more information on roundabout types and design.



### 1300.03(6) Traffic Control Signals

Signalized intersections may offer the following:

- Increased capacity of the intersection compared to stop-controlled intersections.
- Allow for improved progression within a coordinated system along a corridor or a grid.
- Can be used to interrupt heavy traffic at intervals to permit other traffic, vehicular or pedestrian, to complete their movement or enter the intersection.
- Can be preempted to provide priority service to railroad, emergency responders, transit and approaches where advance queue loops are used.
- Reduced at-angle vehicle crashes compared to stop-controlled intersections.

However, signalized intersections:

- Require continual maintenance and engineering for optimal operations.

- Cannot adequately balance large traffic flows with pedestrian demands.
- Can be susceptible to power outages and detection failures.
- Increase rear-end crashes.

Indiscriminate use of traffic signals can adversely affect the safety performance and operational efficiency of vehicle, bicycle, and pedestrian traffic. Therefore, and as required by the MUTCD, a traffic signal should be considered for installation only after if it is determined to meet specific “warrants” and an engineering study shows that the installation would improve safety and/or operations. Satisfying a signal warrant does not mandate the installation of a traffic signal nor by itself meet the requirements of 1300.05; but failing to satisfy at least one warrant shall remove the signal from consideration.

Not all crashes are correctable with the installation of a traffic signal. Traffic signals may decrease the potential for crashes of one type and increase the potential for another type. For instance, at-angle crashes are less frequent with signals because the traffic movements are controlled, but rear-end crashes are more frequent with signals because of stopping and starting of vehicles. At-angle crashes are usually more severe than rear-end crashes; however, the severity of these rear-end crashes tend to be higher at operating speeds above 40 mph. This requires careful consideration of the location characteristics, traffic flow, and crash history.

State statutes (RCW 46.61.085) require WSDOT approval for the design and location of all conventional traffic signals and for some types of beacons located on city streets forming parts of state highways. The Traffic Signal Permit (DOT Form 242-014 EF) is the formal record of the department’s approval of the installation and type of signal. For traffic signal permit guidance, see Chapter 1330.

### 1300.03(7) **Alternative Intersections**

Alternative intersections work mainly by rerouting U and left turns, and/or separating movements. Alternative intersections may have different terminology in different areas, but the most common types include:

- Median u-turn
- Jug handle
- Bowtie
- Restricted crossing u-turn
- Displaced left-turn intersection
- Continuous green tee
- Split intersection
- Quadrant roadway intersection
- Single quadrant interchange
- Echelon
- Center turn overpass

As alternative intersections may be relatively new to Washington State and its users, more education and community engagement will be necessary to help ensure project success. However, extensive experience shows that many of these intersection types can provide better operational and safety performance, often at much less cost than traditional strategies.

Three types of alternative intersections are highlighted in the subsections below: median u-turn, restricted crossing u-turn, and displaced left-turn intersections. For more information about these and other intersection design solutions, see the Federal Highway Administration (FHWA) Alternative Intersection Design web page:

[http://safety.fhwa.dot.gov/intersection/alter\\_design/](http://safety.fhwa.dot.gov/intersection/alter_design/)

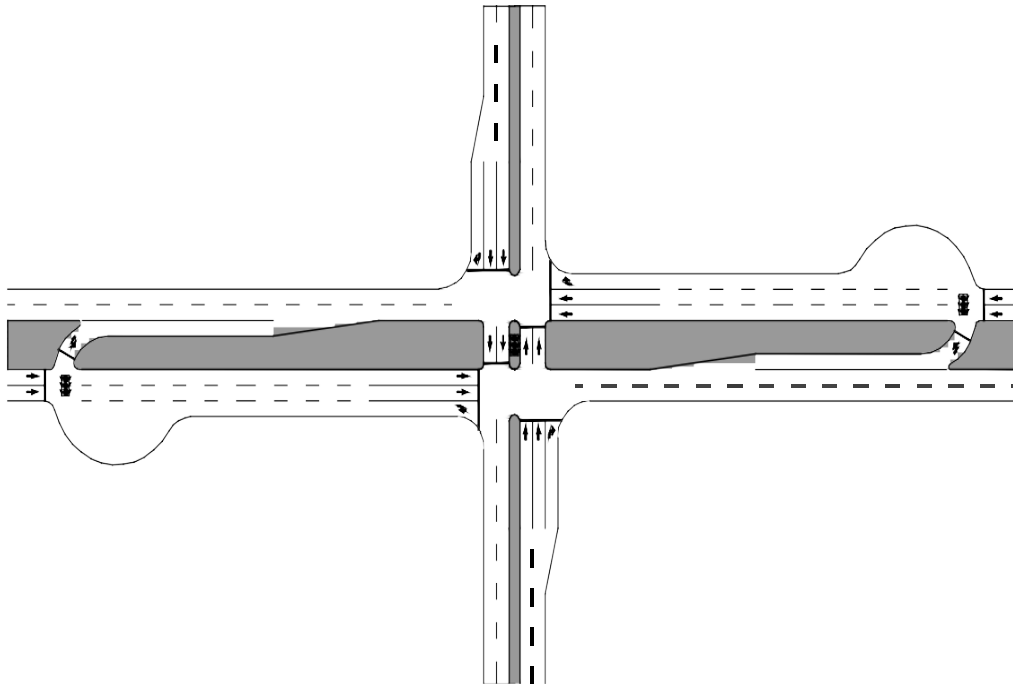
### 1300.03(7)(a) Median U-Turn (MUT)

The MUT intersection treatment relocates left turn movements downstream from the intersection resulting in lower delays, higher throughput, and reduction in the number and severity of crashes. Left-turning drivers proceed straight through the at-grade intersection, and then execute a u-turn at some distance downstream at a new or existing median opening. The main intersection is typically signalized and can be highly efficient needing only two signal phases. By removing the left turns at the main intersection, the MUT design results in a significant reduction in rear-end, angle, and sideswipe crashes; while reducing the number of conflict points from 32 to 16 when compared to a conventional signalized intersection. The MUT can also have advantages for pedestrians with fewer conflict points and a lower delay. However, the intersection design may reduce bicyclist mobility as they are expected to use the pedestrian crossings in order to perform left turns at the intersection. The MUT intersection design is more likely to be suitable for consideration in situations where:

- The intersection is over capacity.
- There are heavy through volumes and low to moderate left turn volumes.
- The intersection is within a higher-speed, multilane, median-divided corridor.
- There are safety concerns at an existing signalized intersection or corridor.

Refer to FHWA's [Median U-Turn Intersection Informational Guide](#) for geometric design considerations and recommendations. (See [Chapter 1310](#) for geometrics when designing the u-turn movement for the MUT intersection.)

#### Exhibit 1300-2 Median U-Turn Intersection Example



MUT Intersection from FHWA's [Median U-Turn Intersection Informational Guide](#)

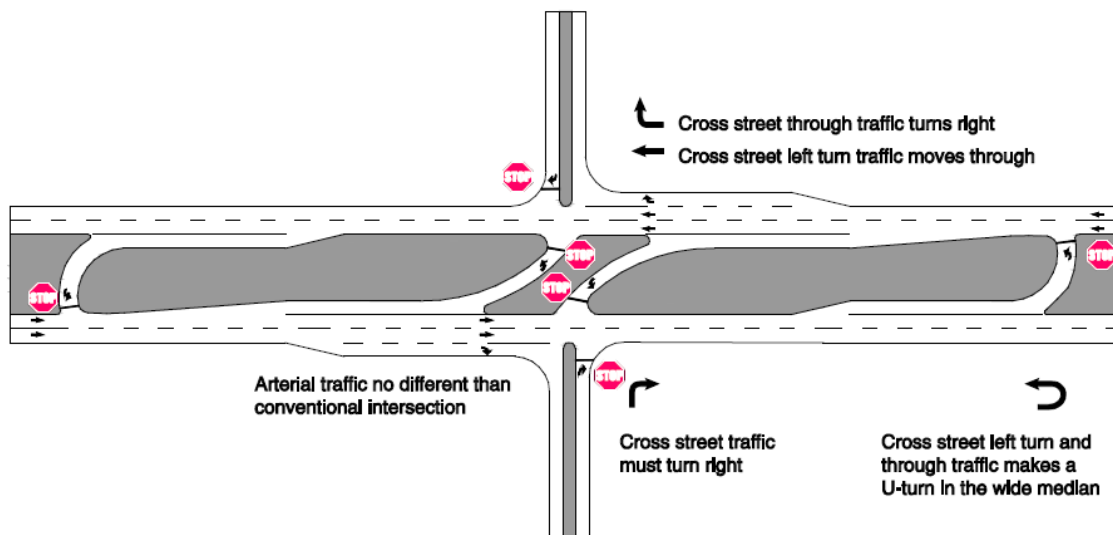
### 1300.03(7)(b) Restricted Crossing U-Turn Intersection (RCUT)

RCUT intersections, also known as superstreets or J-turns, have similarities with the MUT in that the minor road left-turning movements are redirected (see [Exhibit 1300-2](#)). RCUTs, however, also redirect minor road through movements as shown in [Exhibit 1300-3](#). This intersection type results in lower delays, improved progression, and a potential reduction in the total number of crashes and fatal and injury crashes.

Drivers on the minor road approaches must turn right onto the major road and then perform a u-turn maneuver at a median opening downstream. However, the major road left turn movements may still be allowed at the main intersection. RCUT intersections may or may not warrant signalization due to traffic volumes, and those with signalization require fewer signal phases and shorter cycle lengths than a traditional signalized intersection. The RCUT intersection is more likely suitable for consideration in situations where:

- The intersection is over capacity.
- There is a need to improve travel time and progression for the major road.
- There are crashes at the intersection related to turning movements that can be reduced by a RCUT.
- The intersection is within a higher-speed, multilane corridor.
- There are low through and left turn volumes on the minor road.
- Pedestrian volumes are low.
- The major roadway contains sufficient median width, or total right of way width, to support the u-turn movements.

#### Exhibit 1300-3 Restricted Crossing U-Turn Intersection Example with Stop-control



Example of RCUT Intersection with stop-control from FHWA's [Restricted Crossing U-Turn Intersection Informational Guide](#)

The RCUT intersection may be a potential alternative compared to a grade-separated interchange, at locations meeting grade-separated considerations identified in [530.04\(3\)](#). Refer to FHWA's [Restricted Crossing U-Turn Intersection Informational Guide](#) for geometric design considerations and recommendations. (See [Chapter 1310](#) for geometrics when designing the u-turn movement for the RCUT.)

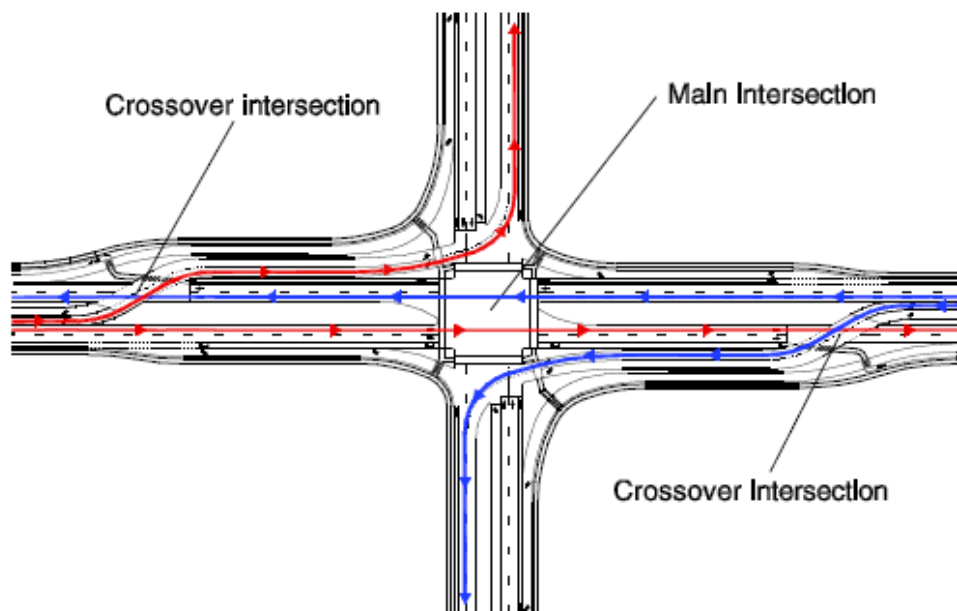


### 1300.03(7)(c) Displaced Left-Turn Intersection (DLT)

The DLT intersection, also known as a continuous flow intersection, works mainly by relocating one or more left turn movements to the other side of the opposing traffic via an interconnected signalized crossover. This essentially causes the traffic signal system to be more efficient by eliminating the left turn phase at the main intersection allowing for more green time to be allocated to other movements. The DLT can reduce delays by up to 40%, but often can be delivered for just slightly more cost than a typical signalized intersection. Compared with a conventional intersection, the DLT can be more challenging for pedestrians due to longer crossing distances and counter-intuitive left turn vehicular movements. However, the DLT typically has shorter cycle lengths and potentially shorter delays. The DLT intersection design is best applied in situations where:

- There are high left-turn and through volumes.
- Intersection is over capacity.
- There are excessive delays and queuing, especially when left turn queues extend past the available storage bays.
- Pedestrian volumes are low.
- Sufficient right-of-way exists on the leg(s) that need to be widened to accommodate the new lanes.
- Context is urban/suburban.

#### Exhibit 1300-4 Displaced Left Turn Intersection Example



*Example of DLT Intersection from FHWA's [Displaced Left Turn Intersection Informational Guide](#)*



## 1300.04 Modal Considerations

When designing a multimodal intersection, consideration needs to be given to all design users at the intersection, the intersection design vehicle and selected modal priority (see [Chapter 1103](#)).

It is not appropriate to design for specific modal treatments on the outset of evaluating intersection control types. However, modally oriented intersection treatments may be necessary to enhance specific modal baseline or contextual performance needs (see [Chapter 1101](#)), and may influence the control type selection. Include a discussion of the potential modally oriented treatments relevant to the control types being analyzed and modal performance needs. Evaluate the potential effect of modal specific treatments on all design users relevant for the control types evaluated in the ICE.

### 1300.04(1) Pedestrian Considerations

Consider the intersection type and how it accommodates pedestrians. With each intersection type, there may be specific elements and/or treatments applicable for pedestrians (see, for example chapters [1231](#) and [1510](#)) to meet modal performance needs identified (see [Chapter 1101](#)).

For example, a signalized intersection with a long cycle length, high vehicle speeds, or frequent permitted turning movements is generally not appropriate for areas with moderate to high pedestrian demand. However, a roundabout or responsive signal in an urban downtown core with low speeds is typically well respected with high compliance and short delays.

Roundabouts often accommodate pedestrian crossings because of high motorist compliance rates, short delays, and minimal disruption to vehicular traffic flow due to short crossing distances, reduced vehicular speeds, and two-stage crossings. Additional strategies may be utilized at multi-lane roundabouts if the pedestrian network and context supports enhanced pedestrian crossings.

Additional information on emerging practices to address pedestrian performance needs for different intersection control types can be found at the Pedestrian and Bicycle Information Center (<http://www.pedbikeinfo.org/>).

For signalized intersections, sidewalk and ramp designs have additional requirements to accommodate the pedestrian features of the traffic signal system (see [Chapter 1330](#)).

### 1300.04(2) Bicycle Considerations

For consideration of bicycle needs at intersections and treatments that may have an operational effect on other design users, see chapters [1515](#) and [1520](#). Additional emerging practice information to address bicycle performance needs for different intersection control types can be found at the Pedestrian and Bicycle Information Center (<http://www.pedbikeinfo.org/>) and the NACTO Urban Bikeway Design Guide (<https://nacto.org/publication/urban-bikeway-design-guide/>).

### 1300.04(3) Transit Considerations

When transit vehicles are identified as a modal priority, consider treatments to meet the performance needs of the specific transit vehicle types and their effect on the performance of other design users (see [Chapter 1103](#)). Transit oriented treatments can vary significantly

depending on the proximity of stop locations with respect to the intersection location and origin of the transit movement (see [Chapter 1430](#) for bus stop placement guidelines), and the type of transit vehicle (such as a fixed guideway vehicle). Discuss treatment options and any operating restrictions the transit provider may have regarding different intersection control types.

### 1300.04(4) Operational Considerations

Traditional delay analysis focuses on determining the peak-hour letter-graded Level of Service (LOS) of an individual intersection. However, as this approach often does not account for multimodal users and as roughly 80% of the daily traffic volumes occur outside of the peak hours, a more encompassing review of the intersection is needed to provide sufficient multimodal capacity and safety performance at all hours of the day.

Intersection control can have an influence on road user behavior and modal operations, not just at the intersection itself, but also along the corridor or surrounding network, even when the intersection has an acceptable LOS. Delay affects route and mode choice and sometimes whether a user will decide to complete the trip. A user's willingness to accept delay depends on many factors including the user's knowledge of the transportation network, anticipated traffic conditions, and alternative options. The increasing presence of in-vehicle guidance systems and real-time traffic apps further aids the user in selecting the route with shortest travel times. Also, some alternatives that may improve mobility for one mode, such as the addition of turn lanes, may result in a performance degradation or even discourage trips for pedestrians or other modes. Thus, it is important to consider the effects of intersection control on the surrounding network and for all potential users. The following are some factors when selecting and evaluating alternatives:

- Access management strategies can be effective in promoting efficient travel patterns and rerouting traffic to other existing intersections. Check with the WSDOT region Planning Office for future land use plans or comprehensive plans to provide for future growth accommodation.
- Consider the volume to capacity (V/C) ratio, the delay, and the queue length of each approach. Some scenarios may require additional sensitivity analysis to determine the impacts of small changes in volumes.
- Examine the effects of existing conditions. Consider progression through nearby intersections (corridor and network analysis) and known risky or illegal driving maneuvers.
- Consider the possibility that traffic from other intersections with lower LOS will divert to the new/revised intersection.

### 1300.05 Procedures

**For new intersections:** determine and document intersection control according to the applicable procedures in this chapter.

**For existing intersections:** An [Intersection Control Evaluation \(ICE\)](#) is required for intersection improvement projects involving pavement construction and/or reconstruction, or preservation projects such as signal replacement/rehabilitation. Evaluate intersection control in accordance with this chapter unless there is documentation that this analysis has already been completed and is referenced in the Project Summary.

An ICE is not required, but should be considered, for existing intersections that are unaffected by the project (per the contributing factors analysis) or are receiving minor revisions such as signal timing changes or rechannelization of existing pavement. Intersection rechannelization within existing pavement can result in operational and safety performance changes that should be evaluated within the existing project framework. Consideration should be given to mainline traffic volume, entering volume, and availability of mainline gaps for additions of left- or right-turn storage within existing intersection width.

### **1300.05(1) Intersection Control Evaluation (ICE)**

The Intersection Control Evaluation, formerly known as the Intersection Control Analysis, is a 5-step process meant to screen and evaluate alternatives to determine the best possible intersection type and design. ***Scale the ICE according to the size and complexity of the project.*** Due to the safety and operational performance record, ***a roundabout is required to be evaluated in Step 1.***

For each alternative, provide a brief description of the assumed layout. Include the number of lanes on major and minor approaches and any measures necessary to accommodate multi-modal users. For a roundabout, document the assumed inscribed circle diameter. For a signal, document the assumed cycle length and phasing strategy used for the analysis.

**Step 1: Background and Project Needs** – Describe the existing conditions. Include physical characteristics of the site, posted speed, AADT, turning movement volumes, channelization and control features, multimodal facilities, context, and modal priority.

Document the project's baseline and contextual needs and performance metrics and targets that will be affected by the intersection. These needs, metrics, and targets will be used for alternative comparison in Step 3. Identify all project alternatives under consideration. For each alternative, determine if it is expected to meet the basic needs of the project. Remove alternatives that do not pass the initial screening, and document their removal. All remaining alternatives are to proceed to Step 2.

**Step 2: Feasibility** – Develop the alternatives at a sketch level to determine the footprint required to achieve performance measures. Consider right-of-way, environmental, cost, context-sensitive/sustainable design, and geometrics/physical constraints for each remaining alternative. If an alternative is not practicable from any of these perspectives, remove it from consideration. For documentation purposes, state why alternatives were removed from further consideration. All remaining alternatives are to proceed to Step 3.

- Determine the **right of way** requirements and feasibility. Discuss the right of way requirements and the feasibility of acquiring that right of way in the analysis. Include sketches or plan sheets with sufficient detail to identify topography, existing utilities, environmental constraints, drainage, buildings, and other fixed objects. An economic evaluation will be useful if additional right of way is needed. Include the right of way costs in the alternatives evaluation (Step 4).
- Identify known **environmental** concerns that could influence control type selection. At this stage, are there any red flags or obvious concerns between potential control types? Are there any known environmental risks that may substantially increase the cost of the project or available information that could help in alternatives comparison? Consult with region Environmental staff for support.

- Consider **Context Sensitive/Sustainable Design**. Context sensitive design is a model for transportation project development. A proposed transportation project is to be planned not only for its physical aspects as a facility serving specific transportation objectives for pertinent modes, but also for its effects on the aesthetic, social, economic, and environmental values, needs, constraints, and opportunities in a larger community setting. Projects designed using this model:
  - Optimize safety of the facility for both the user modes and the community.
  - Promote multimodal solutions.
  - Are in harmony with the community, and preserve the environmental, scenic, aesthetic, historic, and natural resource values of the area.
  - Are designed and built with minimal disruption to the community.
  - Involve efficient and effective use of the resources (time, budget, community) of all involved parties.
  - Minimize maintenance and maximize useful lifetime of the design. See additional guidance in [Chapter 301](#).

**Step 3: Operational and Safety Performance Analysis** – Perform and report the results of applicable analyses for all remaining alternatives and the no-build condition for performance metrics and targets identified in Step 1. The analysis is scalable, but typically should include the metrics below. The level of effort should be based on project complexity, cost of proposed alternatives, context, and impact to the network and other modes. Contact the region Traffic Office early in the process to determine the network area of influence and scope of analysis. Include the following:

- Traffic Analysis – Use the opening year and selected design year for analysis (see [Chapter 1103](#)). In some cases, it may also be appropriate to analyze the horizon year as well. Identify and justify any growth rates used and provide turning movements for all scenarios. There are several deterministic and microsimulation tools for analyzing delay and intersection performance. Traffic volumes and the proximity to other access points will dictate the modeling effort required. Contact the region Traffic Office to determine the appropriate approved tool(s). For more information and guidance on traffic analysis, refer to [Chapter 320](#) and the Traffic Analysis webpage (<http://www.wsdot.wa.gov/Design/Traffic/Analysis/>).
  - Peak hour(s) – Report the delay for each alternative.
  - Off-Peak – Report the delay for an additional time period representative of off-peak travel. Depending on location, up to 80% of total delay can occur in off-peak hours.
  - If a traffic signal is under consideration, perform and report the findings of the signal warrant analysis.
- Safety Performance Analysis – See the [Safety Analysis Guide](#) for ICE safety analysis procedures.
- Multimodal safety and operations – Briefly discuss how the design for each alternative is expected to affect applicable multimodal users. Potential items to consider include pedestrian delay, number of lanes to cross, protected vs permitted turning movements, motorist approach speed, speed differential of users, etc. When applicable, evaluate multimodal treatments that may be necessary for each alternative to meet the performance needs of each user type.

If a roundabout is determined to be the preferred alternative based on analysis conducted in Steps 1 through 3, contact the Region Traffic Engineer to determine if further alternative evaluation is required.

**Step 4: Alternatives Evaluation** – Compare the alternatives based on their ability to address the baseline and contextual needs using the established performance metrics and targets. When applicable, report the Benefit/Cost (B/C) for mobility (due to change in travel time or delay) and/or the B/C for safety (due to change in crash frequency/severity). The B/C analysis may include the following:

- Estimated project costs. May use project costs from similar locations of the alternative as cost justification.
- A qualitative discussion of life cycle cost using the following considerations:
  - Annual maintenance and operations cost. For signals, this should include the cost of signal engineers and technicians to review and implement signal timings and respond to malfunctions and emerging issues. This value can be obtained from the region Traffic Office.
  - Travel time savings in all hours of the day.
- Societal cost savings (considered as the Benefit in the analysis) of reduced crash frequency and/or severity using a predictive method as described in [Chapter 321](#) and the [Safety Analysis Guide](#). See the [Safety Analysis Guide for WSDOT Societal Costs for crash severities](#).
- Salvage value of right of way, grading and drainage, and structures.

**Step 5: Selection** – Based on performance tradeoffs and documented project needs, select the recommended alternative.

#### **1300.05(1)(a) Additional Information**

Discuss the following in the ICE as needed to further support the selection (is it an item that will have a significant effect on the decision?):

- Review the corridor sketch plans and database with the regional planning office.
- Information from a corridor or planning study.
- Current and future land use and whether or not the intersection control will reasonably accommodate future land use traffic changes.
- Community engagement and local agency coordination and comments.
- Effect on future local agency projects.
- Other elements considered in the selection of the intersection control.

### 1300.05(2) **Community Engagement**

Community engagement is a necessary element of project development. Technical, public, and political aspects must be considered. It is critical that community engagement efforts occur with preparation and well-organized content regarding the known performance data associated with different control types to inform communities of the distinct differences between control types with respect to the existing and future contexts and modes. Use the baseline and contextual needs (see [Chapter 1101](#)) identified by the team and informed by the community to help support the options being considered to change operational and safety performance at a given location.



There is often concern from communities regarding control types that may be under consideration, especially the types of intersections that may seem unfamiliar or that break from the traditional approach. Education and outreach efforts, if necessary, are collaborative and are most useful during the analysis and early scoping stages.

Follow the guidelines of WSDOT's Community Engagement Plan ([www.wsdot.wa.gov/planning/](http://www.wsdot.wa.gov/planning/)), and document the effort as indicated in [Chapter 1100](#).

### 1300.05(3) **Approval**

The ICE shall be prepared by or under the direct supervision of a licensed Professional Engineer. Approval of the ICE (see [Chapter 300](#) for more information) requires the following:

- Region Traffic Engineer Approval
- HQ Traffic Approval

### 1300.05(4) **Local Agency or Developer-Initiated Intersections**

[Chapter 320](#) provides guidance for preparation of a Traffic Impact Analysis (TIA). Early in the design process, local agencies and developers should coordinate with the region office to identify specific intersections for further analysis. The project initiator provides an Intersection Control Evaluation (ICE) for approaches and intersections with state routes per [1300.05](#), or references this information in the TIA. The project initiator documents the design considerations and submits the ICE and all documentation to the region for approval (per [1300.05](#)). After the ICE is approved, finalize the intersection design and obtain approval per [Chapters 300](#) (for documentation), [1310](#) (for intersections), [1320](#) (for roundabouts), and [1330](#) (for traffic signals).

### 1300.06 **Documentation**

Refer to [Chapter 300](#) for additional design documentation requirements.

### 1300.07 **References**

#### 1300.07(1) **Federal/State Laws, Codes, and Policies**

[Revised Code of Washington \(RCW\) 46.61](#), Rules of the road

[Washington Administrative Code \(WAC\) 468-52](#), Highway access management – access control classification system and standards

[Secretary's Executive Order: E 1082](#), *Business Practices for Moving Washington*, August 2012, WSDOT

### **1300.07(2) Design Guidance**

*A Policy on Geometric Design of Highways and Streets* (Green Book), AASHTO Current Edition

*Highway Capacity Manual* (HCM), latest edition, Transportation Research Board, National Research Council

*Local Agency Guidelines* (LAG), M 36-63, WSDOT

*Manual on Uniform Traffic Control Devices for Streets and Highways*, USDOT, FHWA; as adopted and modified by [Chapter 468-95 WAC](#) "Manual on uniform traffic control devices for streets and highways" (MUTCD)

*Standard Plans for Road, Bridge, and Municipal Construction* (Standard Plans), M 21-01, WSDOT

[WSDOT Safety Analysis Guide](http://www.wsdot.wa.gov/Design/Support.htm) <http://www.wsdot.wa.gov/Design/Support.htm>

### **1300.07(3) Supporting Information**

*Highway Safety Manual* (HSM), AASHTO

[Roundabouts: An Informational Guide](#), FHWA-RD-00-067, USDOT, FHWA

[Roundabouts: An Informational Guide, Second Edition, NCHRP Report 672](#), Transportation Research Board, 2010

A Review of the Signalized Intersections: Informational Guide. FHWA-HRT-04-092, USDOT, FHWA, APRIL 2004. [www.fhwa.dot.gov/publications/research/safety/04092/](http://www.fhwa.dot.gov/publications/research/safety/04092/)

*Choosing Intersection Control*, IMSA Journal, Buckholz, Nov/Dec 2002.  
[www.imsasafety.org/journal/nd02/buckholz.pdf](http://www.imsasafety.org/journal/nd02/buckholz.pdf)

[A Comparison of a Roundabout to Two-way Stop Controlled Intersections with Low and High Traffic Volumes](#), Luttrell, Greg, Eugene R. Russell, and Margaret Rys, Kansas State University

[Guidance for Implementation of the AASHTO Strategic Highway Safety Plan, Volume 5: A Guide for Addressing Unsignalized Intersection Collisions](#), NCHRP Report 500, Transportation Research Board, 2003

[Guidance for Implementation of the AASHTO Strategic Highway Safety Plan Volume 12: A Guide for Reducing Collisions at Signalized Intersections](#), NCHRP Report 500, Transportation Research Board, 2004

U-turn Based Intersections, FHWA

<https://safety.fhwa.dot.gov/intersection/innovative/uturn/>

Crossover-Based Intersections, FHWA


<https://safety.fhwa.dot.gov/intersection/innovative/crossover/>

[Synthesis of the Median U-Turn Intersection Treatment, Safety, and Operational Benefits](#), FHWA-HRT-07-033, USDOT, FHWA

[Alternative Intersections/Interchanges: Informational Report \(AIR\)](#), FHWA-HRT-09-060, Hughes et al., USDOT, FHWA, 2010

[Field Evaluation of a Restricted Crossing U-Turn Intersection](#), FHWA-HRT-12-037, USDOT, FHWA

[Roundabouts and Sustainable Design](#), Ariniello et al., Green Streets and Highways – ASCE, 2011

Pedestrian and Bicycle Information Center  [www.pedbikeinfo.org/](http://www.pedbikeinfo.org/)

Community Engagement Plan, WSDOT  <http://www.wsdot.wa.gov/planning/default.htm>



- 1320.01 General
- 1320.02 Roundabout Types
- 1320.03 Capacity Analysis
- 1320.04 Geometric Design
- 1320.05 Pedestrians
- 1320.06 Bicycles
- 1320.07 Signing
- 1320.08 Pavement Marking
- 1320.09 Illumination
- 1320.10 Road Approach, Parking, and Transit Facilities
- 1320.11 Geometric Design Peer Review
- 1320.12 Documentation and Approvals
- 1320.13 References

## 1320.01 General

Modern roundabouts are near-circular intersections at grade. They are an effective intersection type with fewer conflict points and lower speeds, and they provide for easier decision making than other intersection types. They also require less maintenance than traffic signals. Well-designed roundabouts have been found to reduce crashes (especially fatal and severe injury collisions), traffic delays, fuel consumption, and air pollution. They also have a traffic-calming effect by reducing vehicle speeds using geometric design rather than relying solely on traffic control devices.

Roundabout design is an iterative process.

A well-designed roundabout achieves a balance of safety and efficiency.

Good design is a process of creating the smooth curvature, channelization, and deflection required to achieve consistent speeds, well-marked lane paths, and appropriate sight distance.



*Roundabout*

The decision to install a roundabout is the result of an [Intersection Control Evaluation \(ICE\)](#) (see [Chapter 1300](#)) approved by the region Traffic Engineer or other designated authority.

## 1320.02 Roundabout Types

There are five basic roundabout types: mini, compact, single-lane, multilane, and teardrop described in the following sections.

### 1320.02(1) Mini-Roundabouts

Mini-roundabouts are small single-lane roundabouts generally used in 25 mph or less urban/suburban environments. Because of this, mini-roundabouts are typically not suitable for use on higher-volume (greater than 6,000 AADT) state routes. In retrofit applications, mini-roundabouts are relatively inexpensive because they normally require minimal additional pavement at the intersecting roads. A 2-inch mountable curb for the splitter islands and the central island is desirable because larger vehicles might be required to cross over it.

A common application is to replace a stop-controlled or uncontrolled intersection with a mini-roundabout to reduce delay and increase capacity. With mini roundabouts, the existing curb and sidewalk at the intersection can sometimes be left in place.

### 1320.02(2) Compact Roundabouts

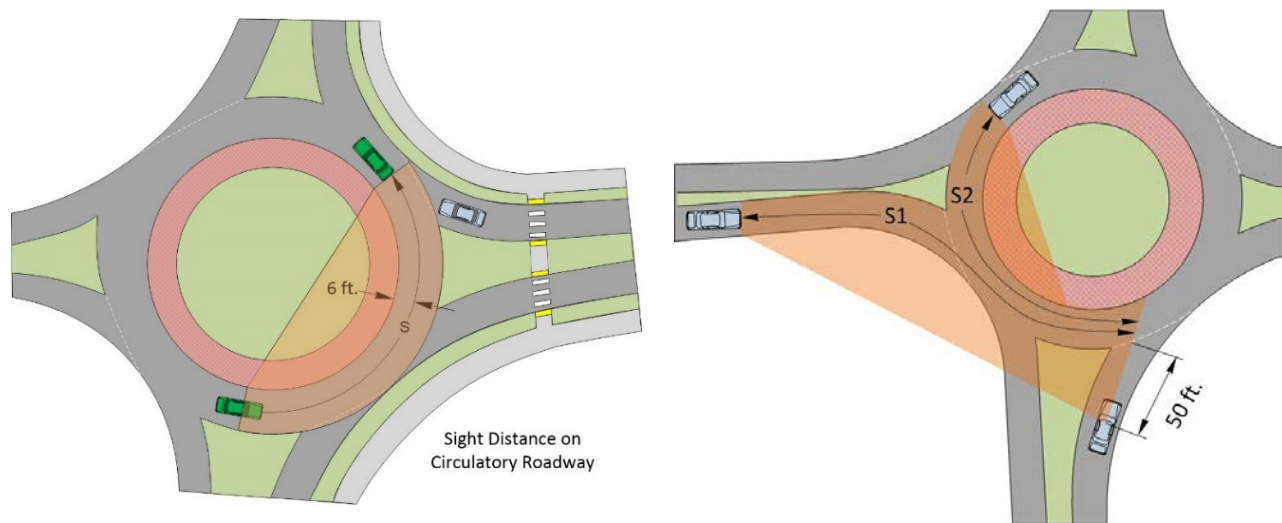
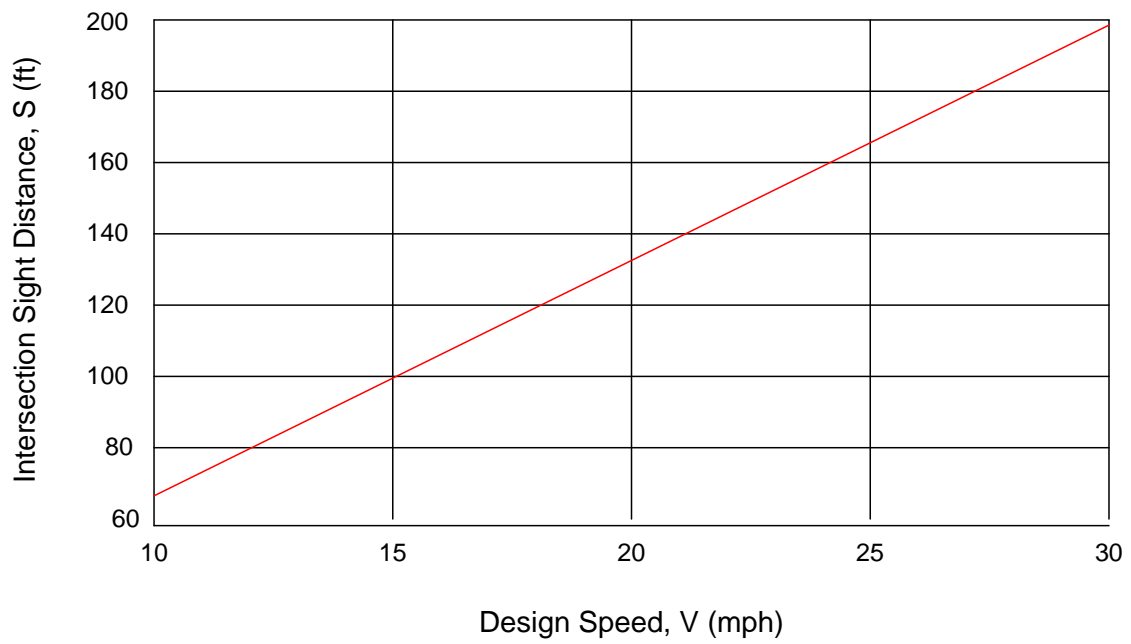
Compact roundabouts are a hybrid of attributes found in mini- and single-lane roundabouts. Similar to a mini-roundabout, a compact roundabout may require minimal additional pavement, has a completely mountable center island, and in many cases existing curb or sidewalk can be left in place. As a result, compact roundabouts rarely require the purchase of right of way. Compact roundabouts are similar to single-lane roundabouts regarding design vehicle assumptions, ability to process traffic volumes, and signing.



*Compact roundabouts*



Exhibit 1320-3 Intersection Sight Distance



### 1320.04(8) Railroad Crossings

Although it is undesirable to locate any intersection near an at-grade railroad crossing, this situation exists at many locations on the highway system. Experience shows that a roundabout placed near a crossing has some operational advantages. If there is a railroad crossing near the roundabout contact HQ Traffic Office for further guidance.

### 1320.05 Pedestrians

As part of the approved ICE it has already been determined whether pedestrians will use the roundabout and, if so, which legs (see [Chapter 1300](#)).

With the knowledge of where pedestrian facilities are needed, design the roundabout while keeping in mind the ADA requirements for crosswalks, sidewalks, paths, and other pedestrian facilities.

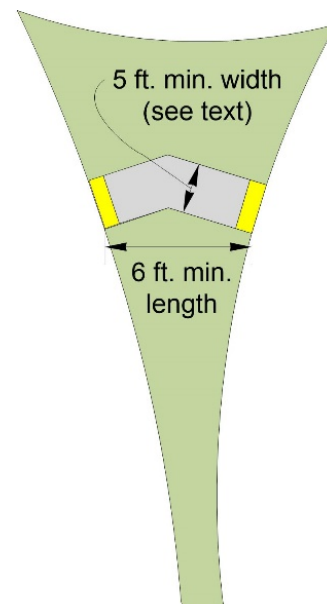
#### 1320.05(1) Crossing Location

The pedestrian crossing located on the entry side of a roundabout leg should be at least 20 feet from the yield line so that a pedestrian can walk behind a vehicle that is waiting at the yield line. If there is an extremely large truck percentage, consider moving the crossing to accommodate the most common truck.

The crossing located in the exit side of the roundabout leg can be closer to the roundabout, because as the vehicles leave the roundabout, they accelerate and make it harder to find a break in traffic. As speed increases, drivers are less likely and less able to stop. Verify that no significant, large sight obstructions are located within the sight lines.

#### 1320.05(2) Splitter Island Pass Through

Design the splitter island pass through a minimum of 5 feet wide, or the width of the sidewalk, whichever is greater. The length of the pass through (measured back of curb to back of curb of the splitter island) is to be a minimum of 6 feet long measured along the shortest section of the pedestrian path. Consider a "V" shape pass through as shown.



*Splitter island pass through*

#### 1320.05(3) Buffers

Wherever feasible, separate sidewalks from the curb with a buffer. Landscaping or colored concrete are acceptable for the buffer. See WSDOT [Standard Plan F10-18](#) for dimension details. Do not compromise required vehicle sight triangle needs.

The buffer discourages pedestrians from crossing to the central island or cutting across the circulatory roadway of the roundabout. It also helps guide pedestrians with vision impairments to the designated crosswalks, and can accommodate the occasional inexperienced truck driver who encroaches up onto a curb while traversing through the roundabout.

- 1330.01 General
- 1330.02 Procedures
- 1330.03 Intersection Design Considerations
- 1330.04 Conventional Traffic Signal Design
- 1330.05 Preliminary Signal Plan
- 1330.06 Operational Considerations for Design
- 1330.07 Documentation
- 1330.08 References

## 1330.01 General

Traffic control signals are automated traffic control devices that warn or direct motorists to take a specific action. Traffic control signals are used to control the assignment of right of way at locations where conflicts with motorists, bicyclists, and pedestrians exist or where passive devices such as signs and markings do not provide the necessary flexibility of control to move motorists, bicyclists, and pedestrians in an efficient manner.

The decision to install a traffic signal is the result of an Intersection Control [Evaluation \(ICE\)](#) (see [Chapter 1300](#)) that is approved by the region Traffic Engineer or other designated authority.

## 1330.02 Procedures

### 1330.02(1) Traffic Signal Permit

State statutes (RCWs) require [WSDOT](#) approval for the design and location of all conventional traffic signals and some types of beacons located on city streets forming parts of state highways. Approval by WSDOT for the design, location, installation, and operation of all other traffic control signals installed on state highways is required by department policy.

The Traffic Signal Permit ([DOT Form 242-014 EF](#)) is the formal record of the signal warrant analysis required by the MUTCD and the department's approval of the installation and type of signal. Permits are required for the following types of signal installations:

- Conventional traffic signals
- Emergency vehicle signals
- Intersection control beacons
- Lane control signals
- Movable bridge signals
- Ramp meter signals
- Pedestrian signals
- Pedestrian Hybrid Beacon signals ("HAWK" signals)
- Temporary traffic signals (only when not being used in place of a permanent, permitted signal)
- Queue-cutter traffic signals

The Permit and its supporting data must be included in the Design Documentation Package (DDP.) The permit is completed by the requesting agency and submitted, complete with



supporting data, through the region Traffic Office to the approving authority for approval. See [1330.02\(1\)\(a\)](#) for Signal Warrant information required as part of the supporting documentation.

The approving authority is the Regional Administrator or authorized delegate. The approving authority approves or denies the application and sends it back to the region Traffic Office. The region Traffic Office retains a record of the approved permit and supporting data and forwards a copy of the Permit and the supporting data to the State Traffic Engineer at WSDOT Headquarters (HQ). Preserve the approved permit as required by [1330.07](#) Documentation.

Emergency vehicle signals require annual permit renewal. The region Traffic Office reviews the installation for compliance with requirements. If satisfactory, the permit is renewed by the Regional Administrator with a letter to the operating agency. A copy of this letter is also sent to the State Traffic Engineer.

Permits are not required for portable traffic signals, speed limit sign beacons, stop sign beacons, or lane assignment signals at toll facilities.

A new permit application is required when the level of control is increased, such as changing from an intersection control beacon to a conventional traffic signal or adding an approach to an existing signal system.

For a reduction in the level of control, such as converting a conventional signal to a flashing intersection beacon or removal of the signal, submit the "Report of Change" portion of the traffic signal permit, complete with supporting data, to the approving authority, with a copy to the region Traffic Office and State Traffic Engineer.

If experimental systems are proposed, region Traffic Engineer review and approval is required. The region Traffic Office will send the approved proposal to the State Traffic Engineer for review and approval. The State Traffic Engineer will forward the approved proposal to FHWA for their approval. A copy of the approval from FHWA will be returned and must be preserved as required by [1330.07](#) Documentation.

Any signal system requiring a permit, with the exception of Ramp Meter signals, also requires Preliminary Signal Plan approval from the WSDOT HQ Traffic Office (see [1330.05](#)).

### **1330.02(1)(a) Signal Warrants**

A signal warrant is a minimum condition that is to be met before a signal may be considered for installation. Satisfying a warrant does not mandate the installation of a traffic signal. The warranting condition(s) supports the inclusion of a traffic signal for consideration as part of the ICE performed during the scoping of the project (see [Chapter 1300](#)). For a list of the traffic signal warrants and information on how to use them, see the [Manual on Uniform Traffic Control Devices](#) (MUTCD). Contact the region Traffic Engineer for region specific practices.

Address all warrants listed in the currently adopted MUTCD as part of the Signal Warrant Analysis. Mark warrants which do not apply as "Not Applicable" and include a basic supporting statement or similar justification. Include the Signal Warrant Analysis in the Signal Permit supporting data. For Warrant 7, the three year period must be used for all traffic signals installed on state highways as described in FHWA Interim Approval IA-19 ([https://mutcd.fhwa.dot.gov/resources/interim\\_approval/ia19/index.htm](https://mutcd.fhwa.dot.gov/resources/interim_approval/ia19/index.htm)).

## 1330.02(2) Responsibility for Funding, Construction, Maintenance, and Operation

Responsibility for the funding, construction, maintenance, and operation of traffic signals on state highways has been defined by legislative action and Transportation Commission resolutions (see [Exhibit 1330-1](#)). Responsibilities vary depending on location, jurisdiction, and whether or not limited access control has been established. Limited access as used in this chapter refers to full, partial, or modified limited access control that has been established as identified in the Access Control Tracking System:

<http://www.wsdot.wa.gov/design/accessandhearings/>

### Exhibit 1330-1 Responsibility for Facilities

Responsibility for Various Types of Facilities on State Highways				
Area	Responsibility	Emergency Vehicle Signals	Traffic Signals, Pedestrian Signals, & Intersection Control Beacons	Reversible Lane Signals & Movable Bridge Signals
Cities with a population of <u>27,500</u> or greater	Finance	ESD [1]	City [2]	City [2]
	Construct	ESD [1]	City [2]	City [2]
	Maintain	ESD [1]	City [2]	City [2]
	Operate	ESD [1]	City [2]	City [2]
All other locations	Finance	ESD [1]	State/County [3] /Other [4]	State
	Construct	ESD [1]	State/County [3] /Other [4]	State
	Maintain	ESD [1]	State	State
	Operate	ESD [1]	State	State

**Notes:**

[1] ESD refers to the applicable Emergency Service Department.

[2] Does not apply to state highways with established limited access control (see [1330.02\(2\)\(c\)](#)).

[3] Beyond corporate limits due to county activity (see [1330.02\(2\)\(d\)](#)).

[4] Other refers to signals proposed by or required due to third party activity (see [1330.02\(2\)\(g\)](#)).

- (a) **Inside the corporate limits of cities with a population of 27,500 or greater where there is no established limited access control:** The city is responsible for the funding, construction, maintenance, and operation of traffic signals. Population figures can be found at: [www.ofm.wa.gov/pop/](http://www.ofm.wa.gov/pop/)
- (b) **Inside the corporate limits of cities with a population of less than 27,500:** WSDOT is responsible for funding, construction, maintenance, and operation of traffic signals. Population figures can be found at: [www.ofm.wa.gov/pop/](http://www.ofm.wa.gov/pop/)
- (c) **Inside the corporate limits of cities with a population of 27,500 or greater where there is established limited access control:** WSDOT is responsible for funding, construction, maintenance, and operation of traffic signals. Population figures can be found at: [www.ofm.wa.gov/pop/](http://www.ofm.wa.gov/pop/)
- (d) **Outside the corporate limits of cities and outside established limited access control areas:** WSDOT is responsible for funding, construction, maintenance, and operation of a traffic signal when a new state highway crosses an existing county road. When a new county road intersects an existing state highway, WSDOT is responsible for only the maintenance and operation of a traffic signal. The county is responsible for the construction costs of the traffic signal and associated illumination. When it is necessary to construct a traffic signal at

an existing county road and state highway intersection, the construction cost distribution is based on the volume of traffic entering the intersection from each jurisdiction's roadway. The county's share of the cost, however, is limited to a maximum of 50%. The state is responsible for maintenance and operation ([WAC 468-18-040](#)).

- (e) **Outside the corporate limits of cities and inside established limited access control areas:** WSDOT is responsible for funding, construction, maintenance, and operation of traffic signals.
- (f) **Emergency vehicle signals:** The emergency service agency is responsible for all costs associated with emergency vehicle signals.
- (g) **Third party agreement signals:** At those locations where WSDOT is responsible for traffic signals and third party activity justifies the installation of a traffic signal, as determined by an [ICE](#), the following rules apply:
- The third party is responsible for funding the design and construction of the traffic signal system, unless another arrangement is agreed upon with WSDOT.
  - The third party obtains a traffic signal permit.
  - The third party agrees to design and construct the traffic signal in conformance with WSDOT's guidelines and requirements.
  - The third party agrees to submit the design and construction documents to WSDOT for review and approval by the region Traffic Engineer.
  - Preserve all third party provided documents and any third party agreement(s) as required by [1330.07](#) Documentation.

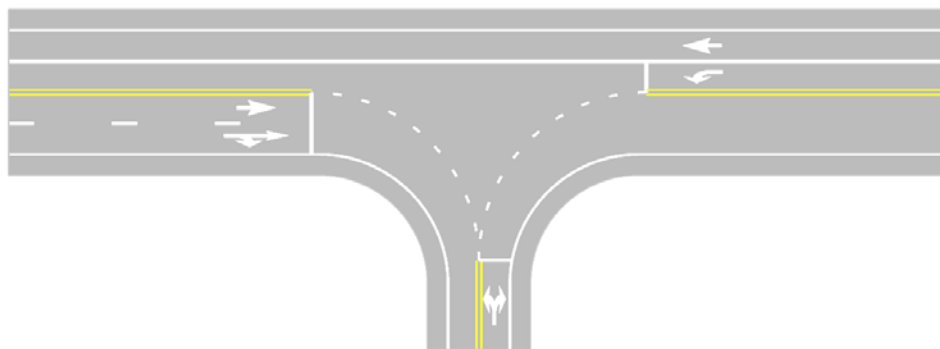
### 1330.03 Intersection Design Considerations

Signalized intersections require different design considerations than non-signalized intersections. These elements should be considered as early as the [ICE](#) process (see Chapters [1300](#) and [1310](#) for further guidance.) This Section discusses basic intersections with relatively simple geometry. For more complex or innovative intersection layouts such as Diverging Diamond Interchanges, Displaced Left Turns, or Single Point Urban Interchanges, contact the WSDOT HQ Traffic Office for support.

Consider providing an unrestricted through lane on the major street of a T intersection (sometimes referred to as a Continuous Green "T" (CGT) intersection). This design allows for one traffic movement to flow without restriction. When this is used on through roadways with a posted speed of 45 MPH or greater, the through lane must be separated by a physical barrier or the through movement must also be signalized. If there is a crosswalk across the through lane, the through lane must be signalized. [Exhibit 1330-2](#) shows an example of a CGT intersection.



### Exhibit 1330-2 Example Continuous Green “T” (CGT) Intersection Layout



#### 1330.03(1) Left Turns

It is recommended that a left turn storage lane be provided for all main line roadways where left turns are allowed. This helps to avoid having stopped traffic in a through lane with a green through signal display. This also helps to support potential future changes in left turn operations. See Section [1330.06\(1\)](#) for additional discussion.

Left-turning traffic can operate more efficiently when the opposing left-turn lanes are directly opposite each other. When a left-turn lane is offset into the path of an opposing through lane, the left-turning driver may assume the opposing vehicles are also in a left-turn lane and fail to yield. To prevent this occurrence, less efficient split phasing may be necessary. (See [Chapter 1310](#) for guidance on lane offsets and opposing left-turn clearance.) Where there are opposing through lanes but no opposing left turn lane, install a striped or raised median area opposite the left turn lane if possible.

Place stop lines so that they are out of the path of conflicting left turns. Check the geometric layout by using turning templates or a computerized vehicle turning path program (such as AutoTURN®) to determine whether the proposed layout and phasing can accommodate the design vehicles. Also, check the turning paths of opposing left-turn movements. In many cases, the phase analysis might recommend allowing opposing left turns to run concurrently, but the intersection geometrics are such that this operation cannot occur. The intersection should be large enough to accommodate opposing left turning vehicle paths with a 4-foot minimum (12-foot desirable) separation between them. Where this separation cannot be achieved, less efficient signal phasing may be required to accommodate opposing left turns.

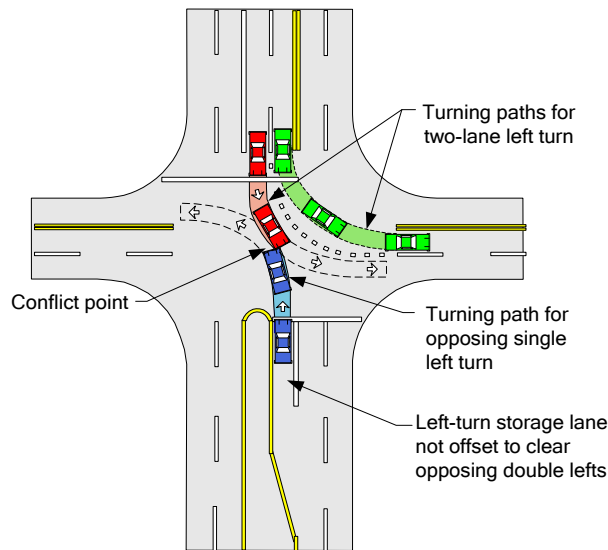
Some intersections may have multi-lane left turns. At locations with closely spaced intersections, a multi-lane left-turn storage area might be the only solution to reduce the potential for the left-turn volume to back up into an adjacent intersection. As with single left turn lanes, the intersection should be large enough to accommodate opposing left turning vehicle paths with a 4-foot minimum (12-foot desirable) separation between them. Where this separation cannot be achieved, less efficient signal phasing may be required to accommodate opposing left turns.

At smaller intersections, the opposing single-lane left-turn movement might not be able to turn during the two-lane left-turn phase and it might be necessary to reposition this lane. If the opposing left turns cannot time together, the reduction in delay from the two-lane left-turn

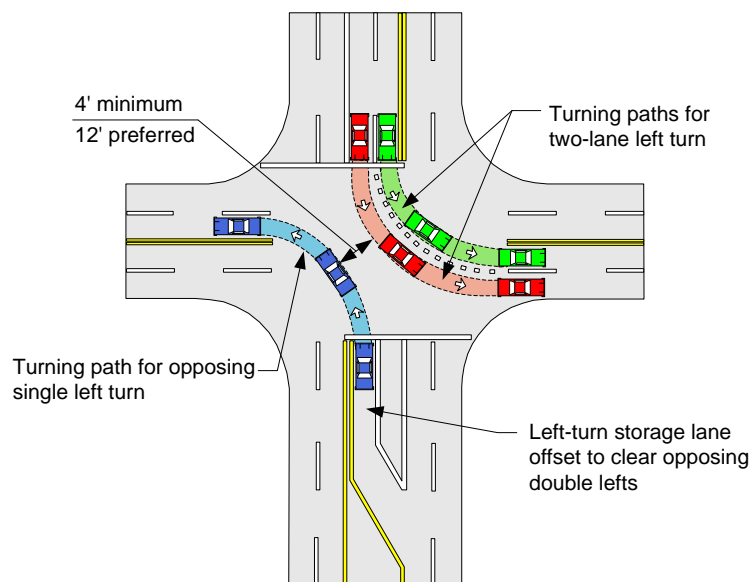
phase is likely to be nullified by the requirement for a separate opposing left-turn phase. [Exhibit 1330-3](#) shows two examples of two-lane left turns with opposing single-left arrangements.

Two receiving lanes are required for two-lane left-turn movements. In addition, these receiving lanes are to extend well beyond the intersection before reducing to one lane. A lane reduction immediately beyond the intersection can cause delays and backups into the intersection because the left-turning vehicles usually move in dense platoons, which may make merging and lane changes difficult. (See [Chapter 1310](#) for guidance on lane reductions on intersection exits.)

**Exhibit 1330-3 Left-Turn Lane Configuration Examples**



Single left turn lane not offset – overlapping left turn paths



Offset single left turn lane – opposing lefts no longer in conflict

### **1330.03(2) Right Turns**

Large right-turn curb radii at intersections sometimes have impacts on traffic signal operation. Larger radii allow faster turning speeds and might move the pedestrian entrance point farther away from the intersection area. Pedestrian crossing times are increased because of the longer crossing, thereby reducing the amount of time available for vehicular traffic. (See [Chapter 1310](#) for guidance on determining these radii.)

At intersections with large right-turn radii, consider installing raised traffic islands. These islands are primarily designed as pedestrian refuge areas. (See [Chapter 1510](#) for pedestrian refuge islands and traffic island designs.) Traffic islands may decrease the required pedestrian clearance intervals; however, large radii and raised traffic islands may make it difficult for pedestrians to navigate the intersection. Where pedestrians are expected to cross a right turn lane to a traffic island, it is recommended to use a compound right turn-lane design as shown in [Chapter 1310](#).

### **1330.03(3) Pedestrian Features**

See [Chapter 1510](#).

### **1330.03(4) Road Approaches and Driveways**

If roadway approaches and driveways are located too close to an intersection, the traffic from these facilities can affect signal operations. Consider eliminating the accesses or restricting them to “right in/right out”. If a driveway or road approach is directly opposite a leg of the intersection, that approach may be signalized. If the approach is signalized, it must be signalized as if it were a standard intersection leg, and the pedestrian crossing across the approach must also be signalized as if it were a standard crosswalk.

Management of driveways and road approaches should be determined early (preferably no later than scoping) so that they can be considered and addressed in the design. (See [Chapters 530](#) and [540](#) for further guidance.) Consider shifting the location of advance detection upstream to clear an access point so that vehicles entering from the access point will not affect detection and operation of the signal.

### **1330.03(5) Skewed Intersections**

Skewed intersections, because of their geometry, are challenging to signalize and delineate. Where feasible, modify the skew angle to provide more normal approaches and exits. In many cases, the large paved areas for curb return radii at skewed intersections can be reduced when the skew angle is reduced. (See [Chapter 1310](#) for requirements and design options.) Visibility of pedestrians is of particular concern, and must also be taken into consideration.

### **1330.03(6) Transit Stops**

Transit stop and pullout locations should be located on the far side of the intersection to minimize their impacts on signal operation. (See [Chapter 1430](#) for transit stop and pullout designs.)

### **1330.03(7) Railroad Crossings**

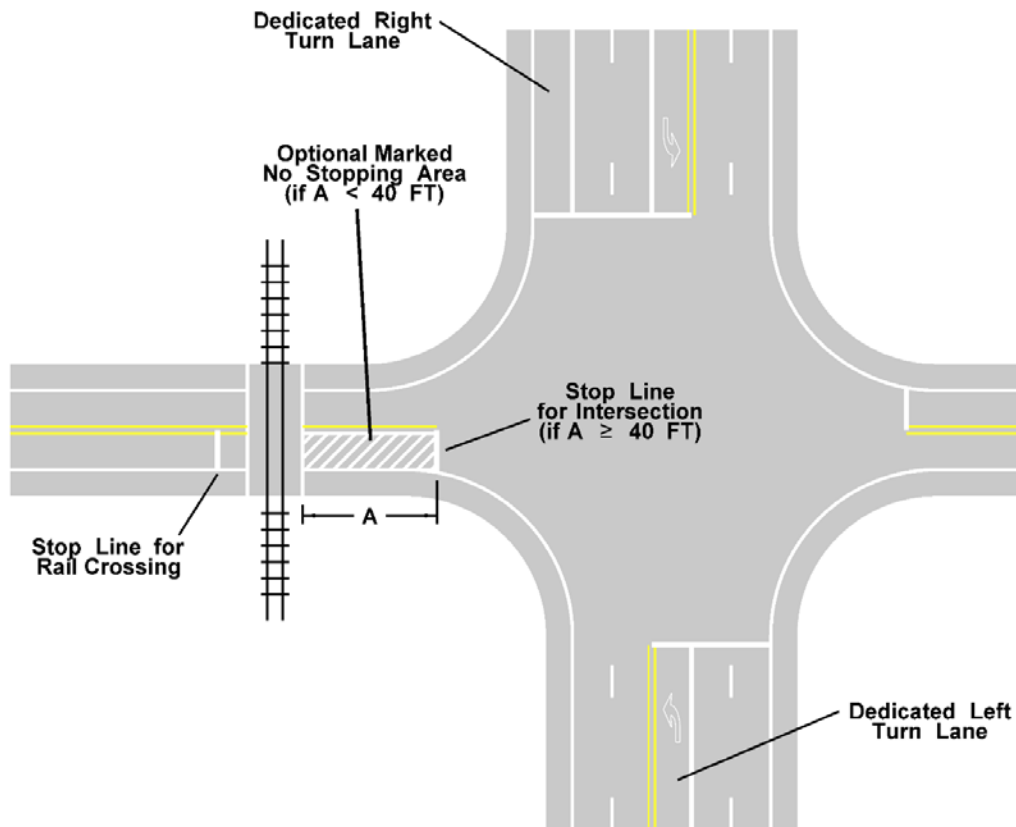
Where railroad preemption is used at a signalized intersection, install left and right turn lanes for the movements leading to the leg of the intersection with the railroad crossing if possible.

This greatly improves the efficiency of the signal during railroad preemption when turns are restricted. Also consider providing a left-turn lane for the minor leg opposing the railroad crossing. This will allow for more effective signal operations during long periods of railroad preemption.

Where there is less than 40 feet between the nearest rail and the normal location of the stop line, do not install a stop line between the tracks and the intersection. Use the same stop line for the traffic signal and the rail crossing instead. Exhibit 1330-4 shows recommended intersection features for intersections near rail crossings.

Contact the WSDOT HQ Traffic Office for assistance with standalone queue-cutter signals.

**Exhibit 1330-4 Recommended Features for Intersections Near Rail Crossings**



## 1330.04 Conventional Traffic Signal Design

### 1330.04(1) General

The goal of any traffic signal design is to assign right of way in the most efficient manner possible and still be consistent with traffic volumes, intersection geometrics, and safety.

An advanced signalized intersection warning sign and beacon assembly to warn motorists of a signalized intersection should be installed when either of the two following conditions exists:

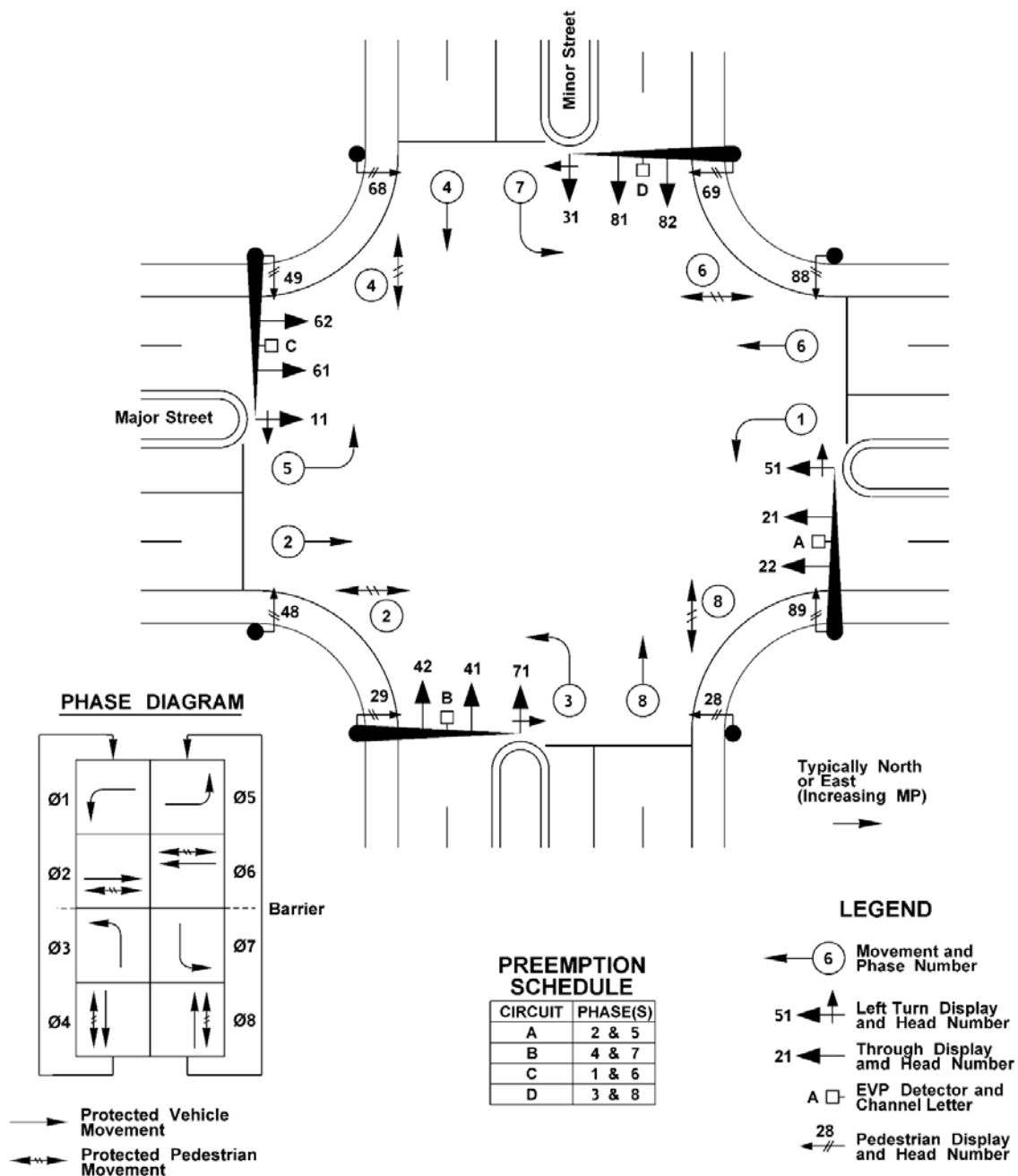
- (a) The visibility requirements in the [MUTCD](#) are not achievable.
- (b) The posted speed is 55 mph or higher and the next nearest signalized intersection is more than 2 miles away; this does not apply to freeway off-ramps.

This warning sign and beacon assembly consists of a W3-3 sign with Type IV reflective sheeting and one or two continuously flashing beacons. Where two beacons are used, the beacons should flash alternately instead of simultaneously. Locate the sign in advance of the intersection in accordance with Table 2C-4 (Condition A) of the [MUTCD](#). The warning sign and beacon assembly may be omitted with approval from the region Traffic Engineer.

### 1330.04(2) Signal Phasing

With some exceptions, the fewer the traffic signal phases, the more efficient the operation of the traffic signal. The number of phases required for efficient operation is related to intersection geometrics, traffic volumes, composition of traffic flow, turning movement demands, and desired level of driver comfort. The traffic movements at an intersection have been standardized to provide consistency in both traffic signal design and driver expectations. (See [Exhibit 1330-5](#) for standard intersection movements, signal head (display) numbering, and standard phase operation.)

Exhibit 1330-5 Standard Intersection Movements, Head Numbers, and Phase Operation



For WSDOT operated signals, the region Signal Operations Engineer will develop the signal phasing plan or review proposed phasing for systems designed by others. For signals operated by other jurisdictions, the operating jurisdiction should be involved in signal phasing development. Phasing development is addressed in 1330.06 Operational Considerations for Design. Phasing development should begin as soon as the decision is made to install a traffic signal and may begin as early as the intersection control evaluation. Provide the proposed channelization plans and traffic count data to the region Signal Operations Engineer or phasing designer as early as possible, as phasing information is required to complete the signal system design.

For WSDOT owned and operated signals, vehicle and pedestrian movement phase numbering is standardized to provide uniformity in signal phase numbering, signal display numbering, preemption channel identification, detection numbering, and circuit identification. For signals owned and operated by other jurisdictions, refer to that jurisdiction's guidelines for phase and equipment numbering. The following are general guidelines for the WSDOT numbering system:

1. Phases 2 and 6 are normally assigned to the major street through movements, with phase 2 assigned to the northbound or eastbound direction of the major street. This results in phase 2 being aligned with the direction of increasing mileposts.
2. Phases 1 and 5 are normally assigned to the major street protected left-turn movements.
3. Phases 4 and 8 are normally assigned to the minor street through movements, with phase 4 normally assigned to the approach to the left of the phase 2 approach (as viewed from the phase 2 stop line).
4. Phases 3 and 7 are normally assigned to the minor street protected left-turn movements.
5. Phasing on new signals installed within an already signalized corridor should be assigned to match the existing corridor phasing – even if it doesn't follow the standard phasing conventions listed above.
6. At T intersections, the movement on the stem of the T is normally assigned to either phase 4 or phase 8. Which phase is used will normally depend on the major street phase assignments.
7. At intersections where split phasing is used (opposing directions time separately) assign phases normally but show the split phase phasing diagram, unless otherwise directed by maintenance and operations staff.
8. Signal displays are numbered as follows:
  - a. The first number indicates the signal phase and the second number is the number of the signal head, counting from centerline (or left edge line) to the right edge line of the approach. For example, signal displays for phase 2 are numbered, as viewed from left to right, 21, 22, 23, and so on. If the display is an overlap, the designation is the letter assigned to that overlap. For example, signal displays for overlap A are number A1, A2, A3, and so on.
  - b. If the display is protected/permissive, the display is numbered with the phase number of the through display followed by the phase number of the left-turn phase. For example, a protected/permissive signal display for phase 1 (the left-turn movement) and phase 6 (the compatible through movement) is numbered 61/11. For overlap right turns, the protected portion may either be an overlap phase, or it may be the same phase as the complementing left turn phase.

With a conventional protected/permissive left-turn display, the circular red, yellow, and green displays are connected to the through phase (phase 6, in this example) controller output and the steady yellow and green arrow displays are connected to the left turn phase (phase 1, in this example) controller output.

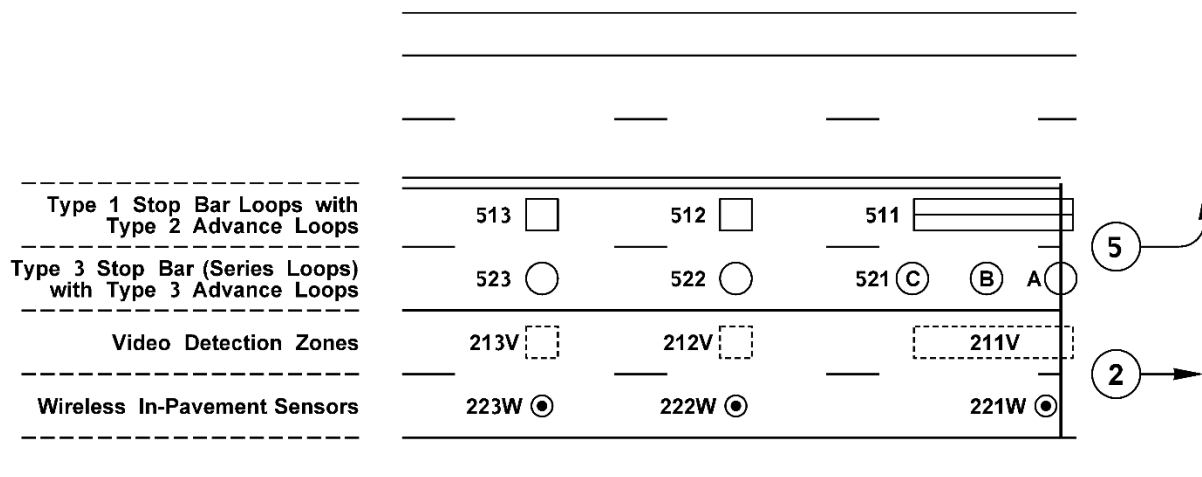
When a flashing yellow arrow display is used, coordinate with the Signal Operations Engineer and signal maintenance group to determine appropriate wiring. For new cabinets, always specify an auxiliary output rack when protected/permissive phasing will be used.

9. Pedestrian displays and detectors are numbered with the first number indicating the signal phase and the second number as either an 8 or 9. For example, pedestrian displays and detectors 28 and 29 are assigned to phase 2. If there are more than two displays or detectors for a single pedestrian phase, use letter suffixes for additional displays and detectors (28A / 29A, 28B / 29B, etc.).
10. Vehicle detector numbering depends on the type of detection:
  - a. Induction loop detectors use three digit numbers for designation. The first number represents the phase. The second number represents the lane number, starting from the left lane and moving towards the right edge line. The third number represents the loop number counting from the stop line back. For example, detection loops for phase 2 detectors are numbered 211, 212, 213 for lane 1; 221, 222, 223 for lane 2; and so on. For loops tied together in series for a single detection channel, such as a three loop series stop line detector, the individual loops in the series use a letter suffix. For a stop line detector in lane 1 for phase 2, using three loops in series, the loops would be designated 211A, 211B, and 211C.
  - b. Video detectors are designated V#, where “#” is the through phase number for that approach, even if it will cover additional phases (such as left turn or overlap) for that approach. If the video detector is for advance detection, the suffix “A” is added. For example, the advance video detector for phase 6 would be V6A.

Video detection zones may be drawn on the contract plans if desired, but these will normally be field established and adjusted and may not end up as shown in the plans. If used, video detection zones are labeled the same as loop detectors, but with a “V” suffix. For example, the stop line video detection zone for phase 5 would be 511V.
  - c. Radar detectors are designated similar to video detectors, but use an “R” prefix in place of the “V”. For example, the advance radar detector for phase 4 would be R4A.
  - d. Wireless in pavement sensors use the same numbering scheme as induction loops, but add a “W” suffix. For example, the phase 7 stop line sensor would be 711W.
  - e. [Exhibit 1330-6](#) shows examples of standard detector numbering.
11. Emergency vehicle detectors use letter designations: Channel A detectors cover phase 2 and phase 5; Channel B detectors cover phase 4 and phase 7; Channel C detectors cover phase 1 and phase 6; and Channel D detectors cover phase 3 and phase 8. When there are multiple detectors for the same channel, the first detector uses the letter, and all other detectors use a number suffix (C, C1, C2, etc.).



**Exhibit 1330-6** Detector Numbering Examples



**Detector Identification Number Legend**

Loop #	5	2	2	W
Phase Number				
Lane Number				
Loop Number				
(Type Suffix)				

**1330.04(3) Vehicle Signal Displays**

Signal displays are the devices used to convey right of way assignments and warnings from the signal controller to the motorists and pedestrians. When selecting display configurations and locations, the most important objective is the need to present these assignments and warnings to the motorists and pedestrians in a clear, concise, and uniform manner.

The use of ball, steady arrow, or flashing yellow arrow displays is dependent upon the signal phasing. Use the approved signal phasing diagram to determine which display types can be used for which movements. Typical vehicle signal displays are shown in Exhibits 1330-7a through 7h. In addition to the display requirements contained in the MUTCD, the following also apply:

1. A minimum of two indications for the through movement, if one exists at an intersection, must be provided - even if it is not the primary (predominant) movement. Provide a minimum of two indications for the major signalized turn movement of an intersection if no through movement exists, such as on the stem of a T intersection. These signal faces are to be spaced a minimum of 8 feet apart. At a T intersection, select the higher-volume movement as the primary movement and provide displays accordingly.

A green left-turn arrow on a primary display and a green ball on the other primary display do not comply with this rule. At an intersection where left turns are prohibited, the leftmost through display may use a green up arrow in place of the green ball display. At an

intersection where right turns are prohibited, the rightmost through display may use a green up arrow in place of the green ball display.

2. All displays for an approach, regardless of phase served, are to be a minimum of 8 feet apart.
3. Locate displays directly overhead and centered over the associated lane of the applicable vehicular traffic as it moves through the intersection. (See [Exhibits 1330-7a](#) through [7h](#) for signal head locations.) For intersections with a skew for through traffic, locate signal displays for through traffic in one of the following ways:
  - a. Over the center of the outbound (far side) lane
  - b. Over a line drawn between the center of the approaching lane and the center of the associated outbound lane, ending at the stop lines

Left turn displays may either be located relative to the through displays or in line with approaching traffic, dependent on ability to mount the display(s). (See [Exhibit 1330-8](#) for skew placement examples.)

4. Locate displays a minimum of 50 feet and a maximum of 180 feet from the stop line. The preferred location of the signal heads is between 60 and 120 feet from the stop line. When the nearest signal face is located between 150 and 180 feet beyond the stop line, engineering judgment of conditions, including worst-case visibility conditions, is to be used to determine whether the provision of a supplemental or nearside signal face would be beneficial. When it is not physically possible to locate displays at least 50 feet from the stop line, the distance to the displays may be reduced as follows:
  - a. 3-section vertical and 5-section cluster (doghouse) displays may be located between 40 and 50 feet from the stop line.
  - b. 4-section vertical displays may be located between 41 and 50 feet from the stop line.
  - c. 5-section vertical displays may be located between 45 and 50 feet from the stop line.

The distances listed above are the minimums required to maintain 16.5 feet of clearance over the roadway with a backplate installed.

Overhead displays should always be located on the far side of the crossing roadway for the best visibility. Locating overhead displays on the near side of the roadway results in issues with visibility and driver compliance with stop lines. When an overhead display is located on the near side of the crossing roadway, the stop line typically has to be pushed back so that the minimum visibility distance is met. However, this also pushes the stop line back too far for drivers to see cross traffic, resulting in drivers creeping past the stop line towards the intersection – especially for turning traffic. This results in both the driver being stopped past the stop line and being unable to see the signal displays.

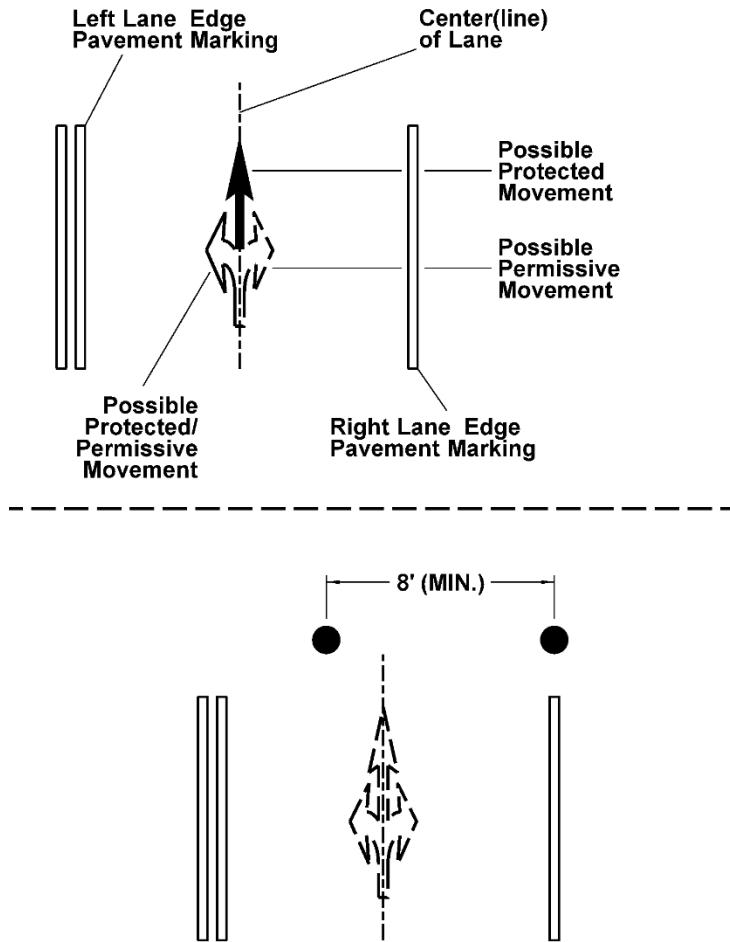
For ramp meter signals, place Type RM signal standards and displays at the stop line.

5. Use vertical vehicle-signal display configurations. Horizontal displays are not allowed unless clearance requirements cannot be achieved with vertical displays or unless they are being installed at an intersection to match other displays in the intersection. Approval by the State Traffic Engineer is required for the installation of horizontal displays.

6. Use 12-inch signal sections for all vehicle displays except the lower display for a post mounted ramp meter signal.
7. Provide displays for turning movements with dedicated lanes as follows:
  - a. For protected movements, use all arrow displays.
  - b. For protected / permissive movements, use four section arrow displays. Alternatively, a shared five section cluster (doghouse) display may be used for both the turn lane and the adjacent through lane. Note: A three section arrow display, with bi-modal flashing yellow arrow / steady green arrow may be used in cases where windload or vertical roadway clearance will not allow for the use of a four-section display. If vertical clearance can be accommodated through adjustments to the signal display mount, such as mounting the Type M mount between different display sections, a four section arrow display should be used.
  - c. For permissive right turns, a three-section arrow display with flashing yellow arrow ([Exhibit 1330-7g](#)) is optional. This display is highly recommended where there are concerns regarding permissive right turns and the conflicting pedestrian crossing movement, such as known incidents or high volumes of both pedestrian crossings and right turn movements.
8. Use steady green arrow indications only when the associated movement is completely protected from conflict with other vehicular and pedestrian movements. This includes conflict with a permissive left-turn movement. At T intersections, steady green arrow displays may not be used for a movement that has a conflicting pedestrian movement.
9. Use either Type M or Type N mountings for vehicle display mountings on mast arms, as directed by the region maintenance staff or owning agency. Provide only one type of mounting for each signal system. Mixing mounting types at an intersection is not acceptable except for supplemental displays mounted on the signal standard shaft.
10. Use backplates for all overhead-mounted displays for new, updated, or rebuilt signal faces. Add backplates to all existing signal displays that do not already have them.
11. Use Type E mountings for pedestrian displays mounted on signal standard shafts unless otherwise approved by region maintenance staff or the owning agency.
12. Include supplemental signal displays when the approach is in a horizontal or vertical curve and the intersection visibility requirements of this section and the MUTCD cannot be met, unless approved otherwise by the region Traffic Engineer.

Supplemental far side displays are recommended at intersections with higher truck volumes, as the trucks will frequently block visibility of overhead displays for following drivers. Supplemental far side protected left turn displays are recommended for long left turns.

Exhibit 1330-7a Signal Display Placements – Key to Diagrams

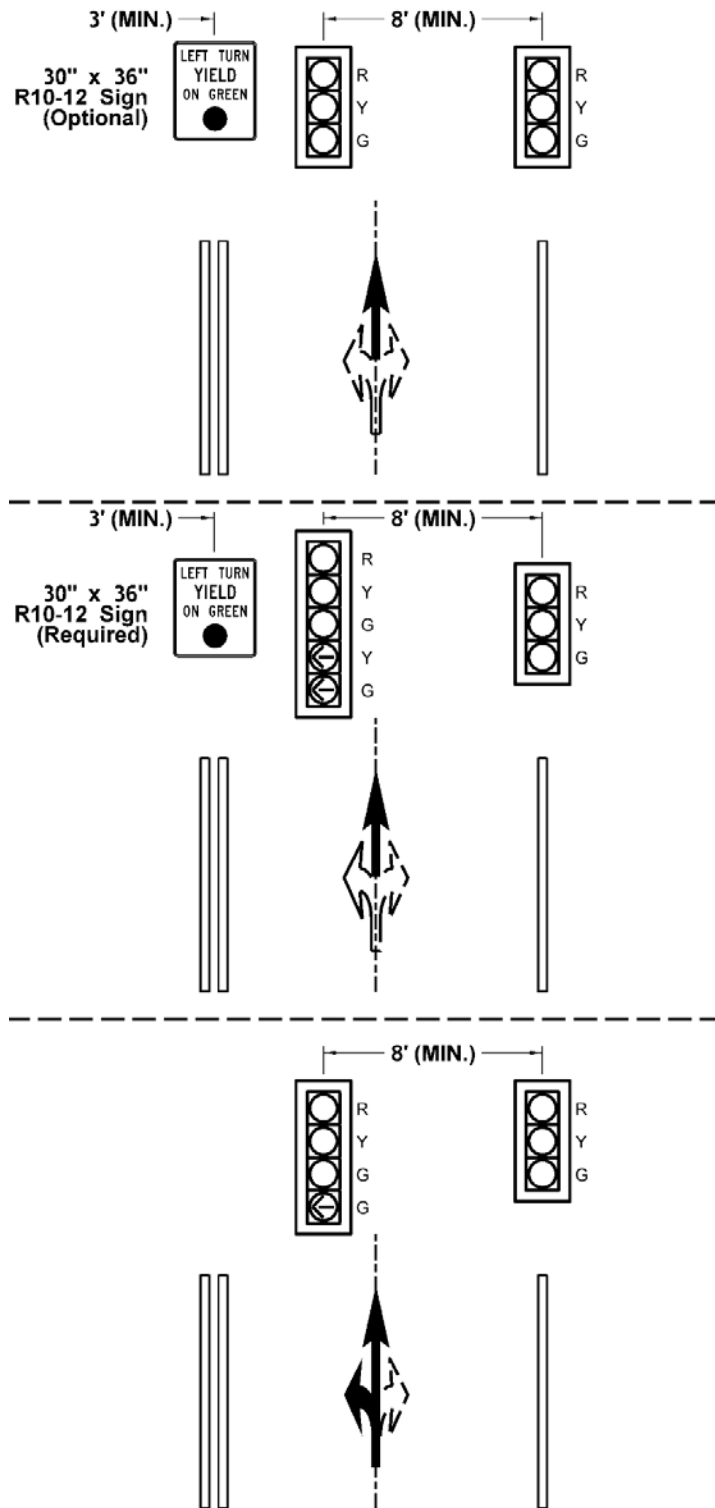


Pavement markings are used to represent possible lane lines and vehicular movements. The lane lines shown are typical, but not necessarily required.

All signal mounts must be a minimum of 8 feet apart, measured center to center.

This example shows typical mount locations for a single approach lane.

Exhibit 1330-7b Signal Displays for Single Lane Approach



Single lane approach with permissive (or no left turns).

R10-12 sign optional.

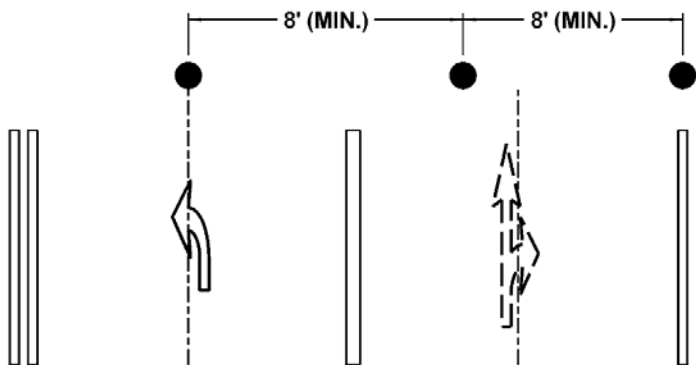
Where left turns are prohibited, install a 30" x 30" R3-2 No Left Turn (Symbol) Sign in place of the R10-12 sign shown here.

Single lane approach with protected / permissive left turns.

R10-12 sign required.

Single lane approach with protected left turns.

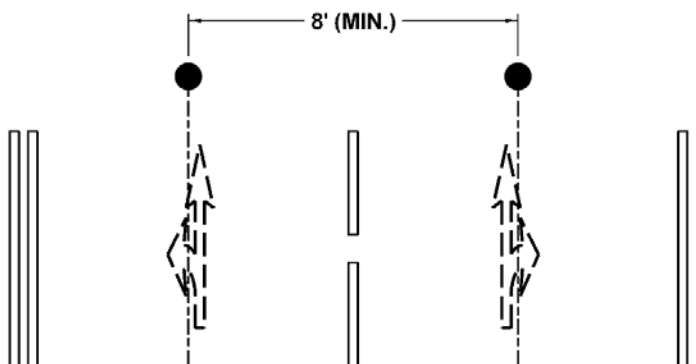
Exhibit 1330-7c Signal Display Mounting Locations for Multi-Lane Approaches



Single through lane with left turn lane(s).

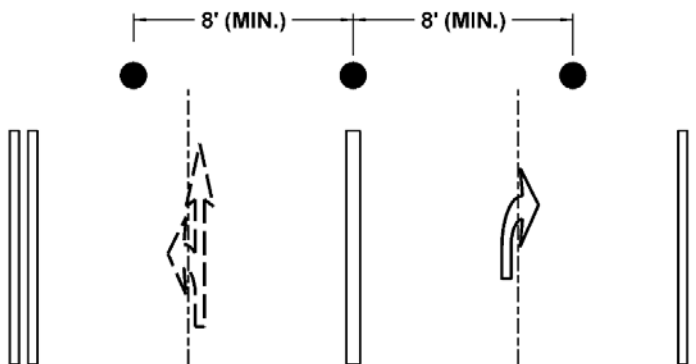
Through lane displays arranged the same as for a single lane approach.

Left turn display(s) centered over lane(s).



Multiple through lanes.

Center displays over each lane.

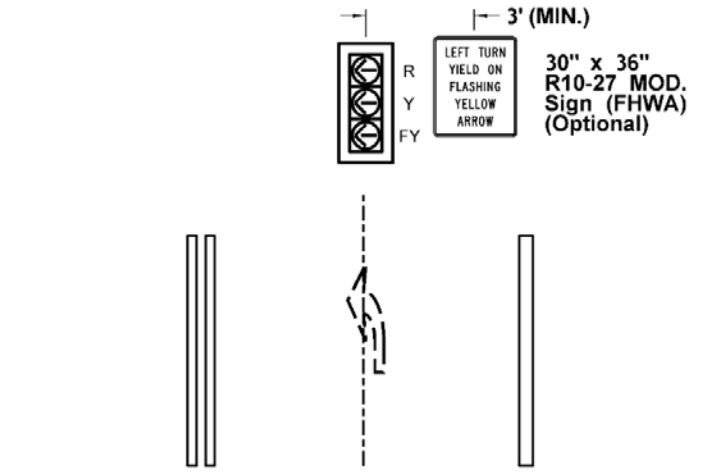


Single through lane with right turn lane(s).

Through lane displays arranged the same as for a single lane approach.

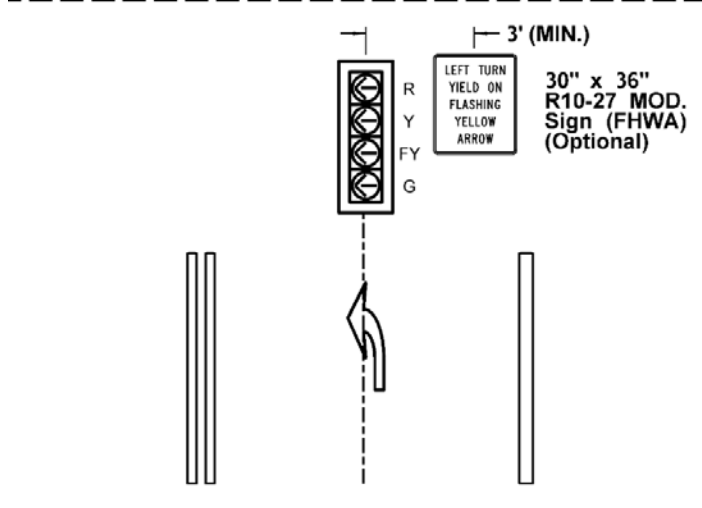
Ensure that the 8-foot spacing requirement is met if a right turn display is installed overhead.

Exhibit 1330-7d Signal Displays for Dedicated Left Turn Lanes



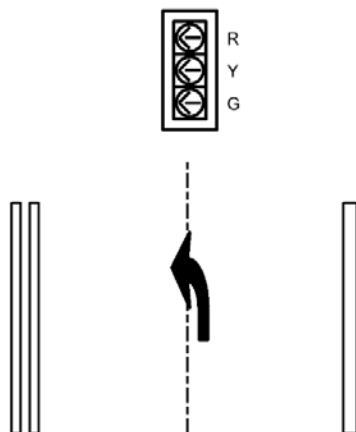
Dedicated left turn lane with permissive left turns.

R10-27 (Modified) sign optional.



Dedicated left turn lane with protected / permissive left turns.

R10-27 (Modified) sign optional.



Dedicated left turn lane with protected left turns.

Exhibit 1330-7e Signal Displays for Shared Through-Left Lanes – Multiple Through Lanes

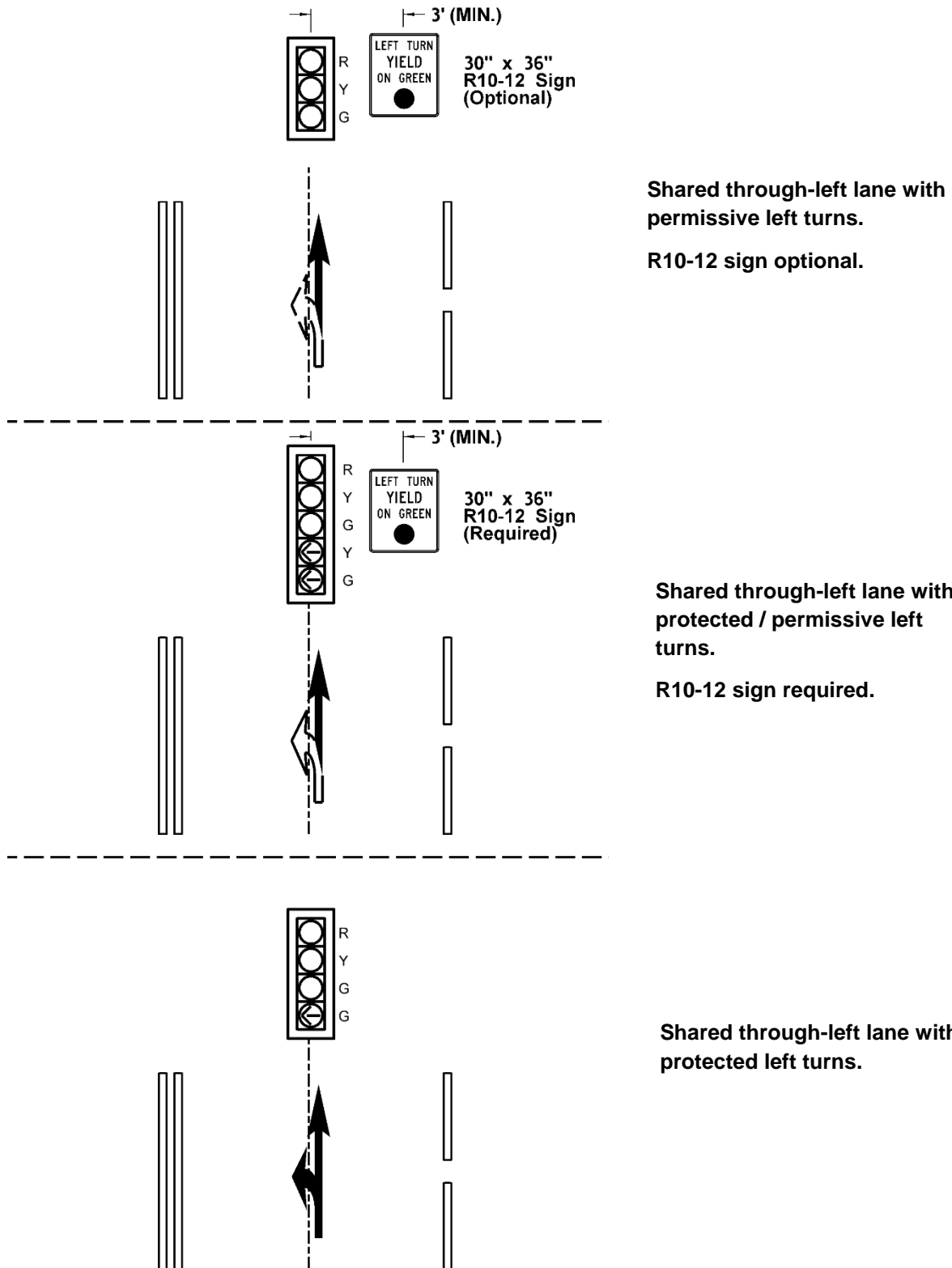
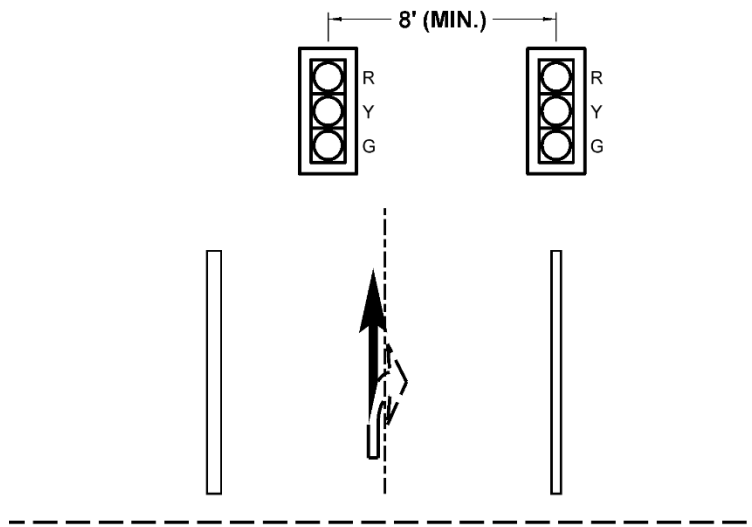
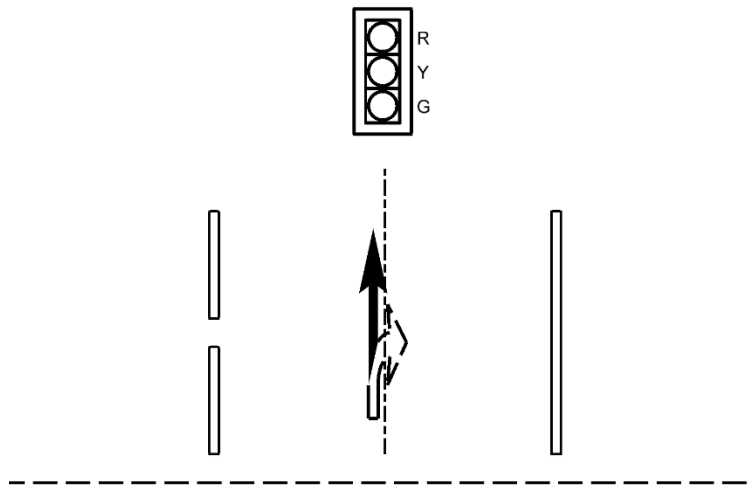




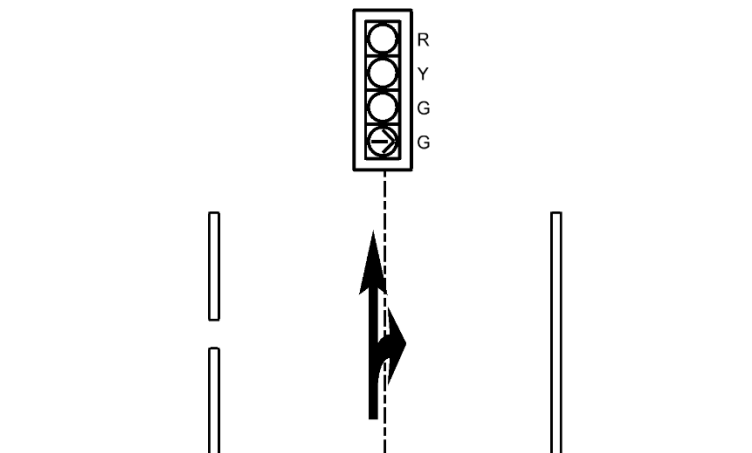
Exhibit 1330-7f Signal Displays for Shared Through-Right Lanes



Single shared through-right lane with permissive right turns.



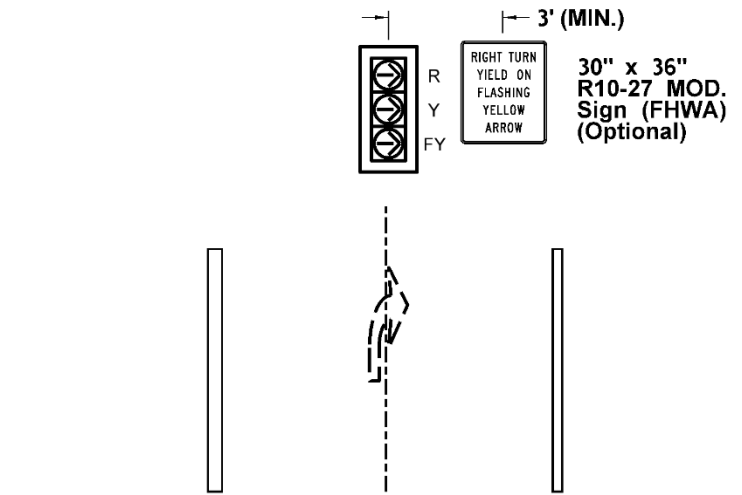
Shared through-right lane, multiple through lanes, with permissive right turns.



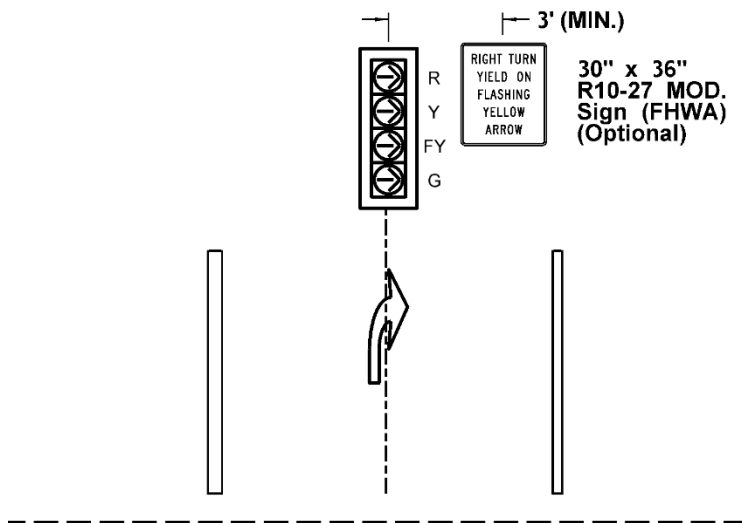
Shared through-right lane, multiple through lanes, with protected right turns.

For protected / permissive right turns, mirror protected / permissive left turn display from [Exhibit 1330-7e](#).

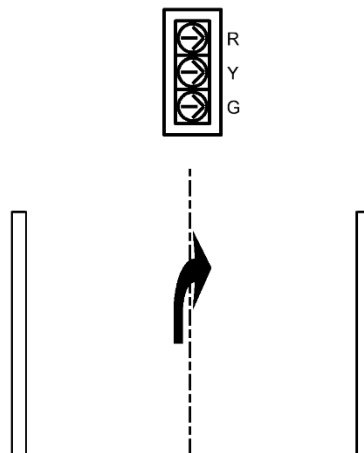
Exhibit 1330-7g Signal Displays for Dedicated Right Turn Lanes



Dedicated right turn lane with permissive right turns.  
R10-27 (Modified) sign optional.

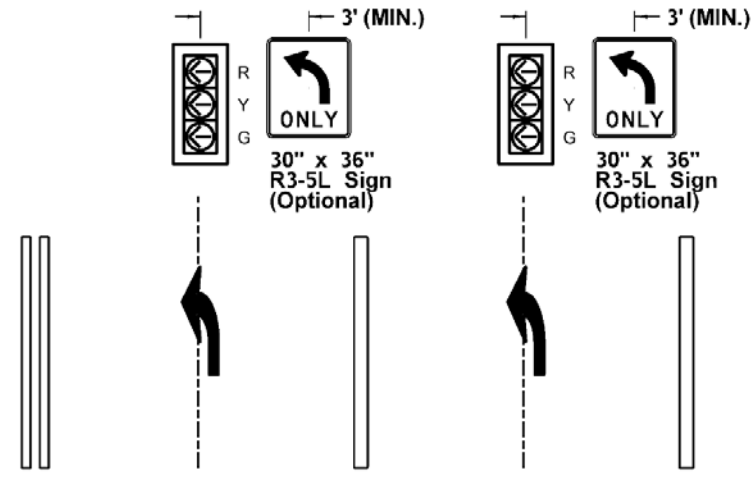


Dedicated right turn lane with protected / permissive right turns.  
R10-27 (Modified) sign optional.

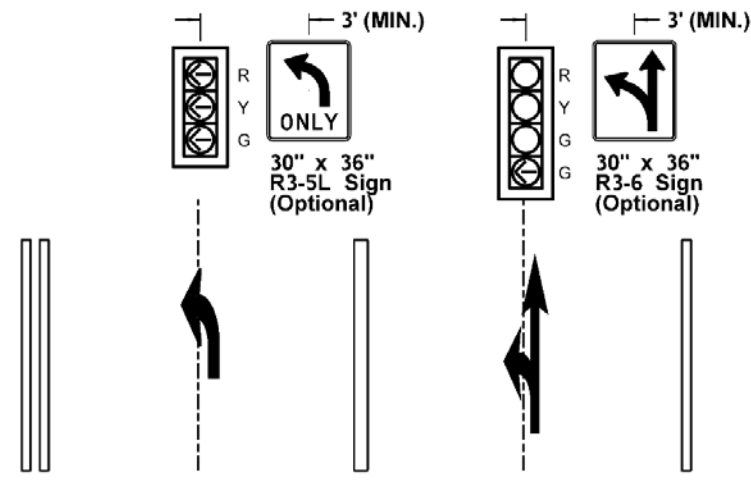


Dedicated right turn lane with protected right turns.

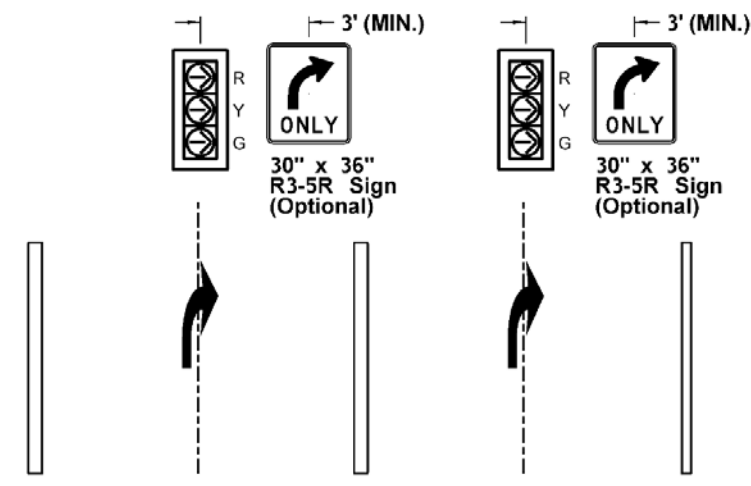
Exhibit 1330-7h Signal Displays for Multiple Turn Lanes



Multiple left turn lanes.  
R3-5L signs optional.

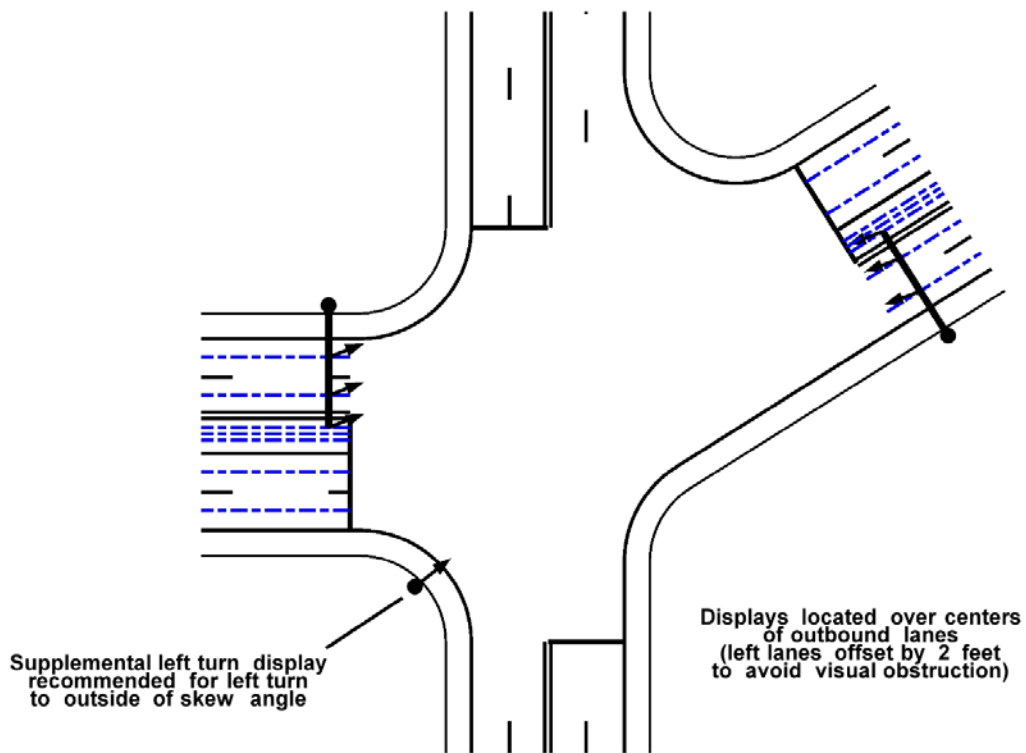
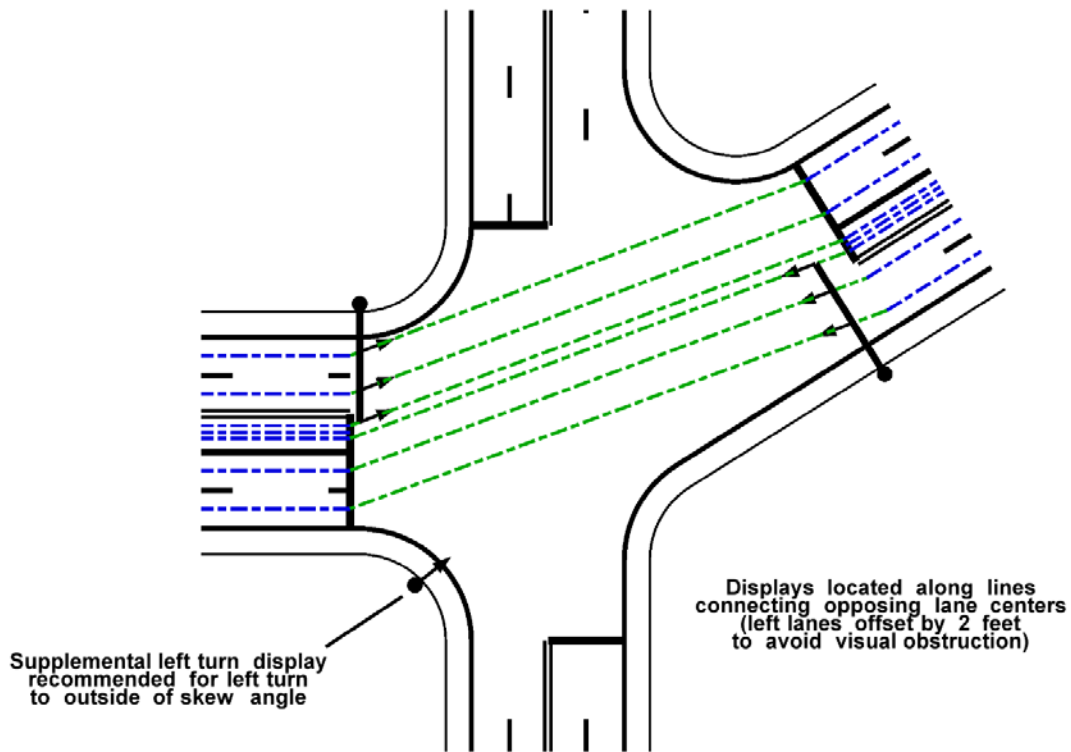


Multiple left turn lanes, with a shared through-left lane.  
R3-5L and R3-6 signs optional.  
Mirror for right turns.



Multiple right turn lanes.  
R3-5R signs optional.

Exhibit 1330-8 Example Signal Display Placement for Skew Intersection



The minimum mounting height for overhead signal displays is 16.5 feet from the roadway surface to the bottom of the signal housing, including the backplate. There is also a maximum height for signal displays allowed by the MUTCD, since the roof of a vehicle can obstruct a motorist's view of a signal display. The maximum heights from the roadway surface to the bottom of the signal display housing with 12-inch displays are shown in [Exhibit 1330-9](#).

#### Exhibit 1330-9 Signal Display Maximum Heights

Distance to Stop Line (ft)	Signal Display Arrangement	Maximum Height (to bottom of display housing <sup>[3]</sup> )
40 <sup>[1]</sup>	Vertical 3-section	17.5 ft
42 <sup>[1]</sup>	Vertical 4-section	17.0 ft
45 <sup>[1]</sup>	Vertical 5-section <sup>[2]</sup>	17.0 ft
53 to 180	Vertical 3-section	22.0 ft
	Vertical 4-section	20.8 ft
	Vertical 5-section <sup>[2]</sup>	19.6 ft
<b>Notes:</b>		
[1] Minimum distance required to achieve 16.5 feet of clearance with backplate installed.		
[2] For 5-section cluster displays, use the Vertical 3-section heights.		
[3] Subtract 0.5 ft for height to bottom of backplate.		

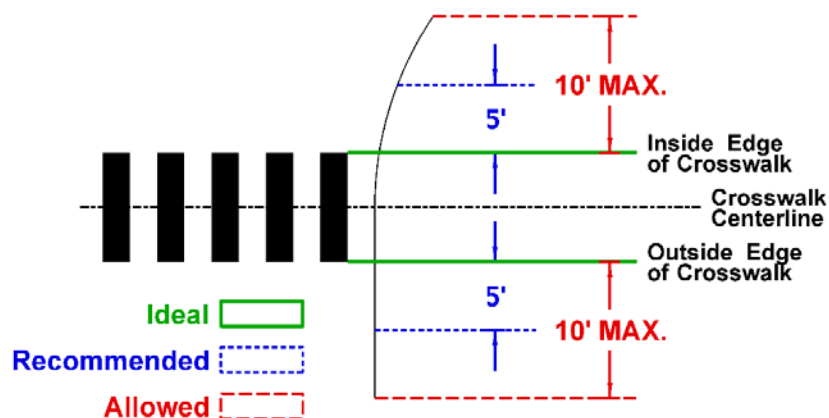
At signalized intersections with railroad preemption, install blankout signs for turning movements that do not have a dedicated signal display (3-section arrow display). Blankout signs are 36" x 36" and will display either a No Right Turn symbol (R3-1) or No Left Turn symbol (R3-2) when activated, as appropriate. Blankout signs should be placed the same as equivalent static signs.

#### 1330.04(4) Pedestrian Equipment

Pedestrian equipment consists of pedestrian signal displays and pedestrian detectors (pushbuttons). New signal systems are required to use countdown displays and Accessible Pedestrian Signal (APS) pushbuttons. See [1330.04\(4\)\(a\)](#) for pedestrian display and detection requirements for existing signal systems. No intersection may have a mix of APS and non-APS pushbuttons, nor may any intersection have a mix of countdown and non-countdown pedestrian displays.

Pedestrian displays are required to be installed with the bottom of the display housing no less than 7 feet or more than 10 feet above the sidewalk surface. Pedestrian displays are required to be installed to provide maximum visibility at the beginning of the controlled crosswalks. To accomplish this, pedestrian displays should be located no more than 5 feet from the outside edge of the crosswalk, as measured on a line perpendicular to the crosswalk centerline (See [Exhibit 1330-10](#)). The offset distance may be offset up to a maximum of 10 feet from the outside edge of the crosswalk if physical constraints prevent the display from being placed no more than 5 feet from the outside edge of the crosswalk.

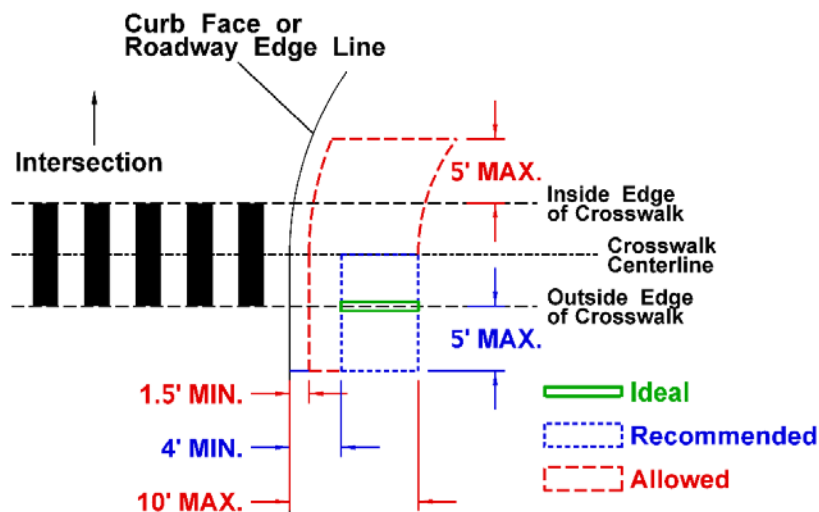
## Exhibit 1330-10 Pedestrian Display Placement Requirements



Pedestrian pushbuttons (PPBs) are required to be located within a certain distance of the crosswalk being served and oriented such that the sign on the pushbutton is parallel to the crosswalk served. Pedestrian pushbutton location requirements are as follows:

- The PPB should be between 4 and 6 feet from the face of curb, where sidewalk is present, or the edge line of the roadway where there is no sidewalk. The PPB may be between 1.5 and 4 feet from the curb face or edge line, but this is not recommended due to proximity to the roadway. The PPB may not be closer than 1.5 feet from the curb face or edge line. If geometric constraints make it impractical to place the PPB within the 4-6 foot range, the PPB should not be further than 10 feet from the edge of curb, shoulder, or pavement. Contact the HQ Traffic Office if the PPB cannot be placed within 10 feet of the curb face or edge line.
- The PPB should be located as close to the outside edge of the crosswalk line as possible, so that for APS PPBs, the button and sign face towards the core of the intersection, rather than back down the adjacent approaching roadway. The PPB may be located no more than 5 feet outside either edge of the crosswalk line.
- If possible, PPBs should be located on separate poles and be separated by a minimum of 10 feet.
- See [Exhibit 1330-11](#) for recommended and allowed PPB placement locations.

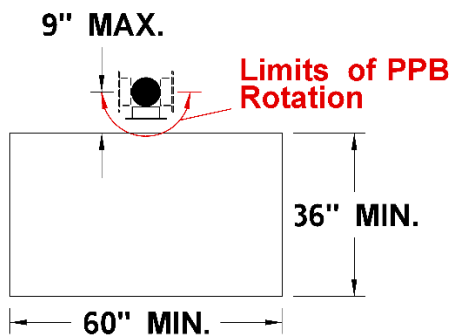
## Exhibit 1330-11 PPB Placement Requirements



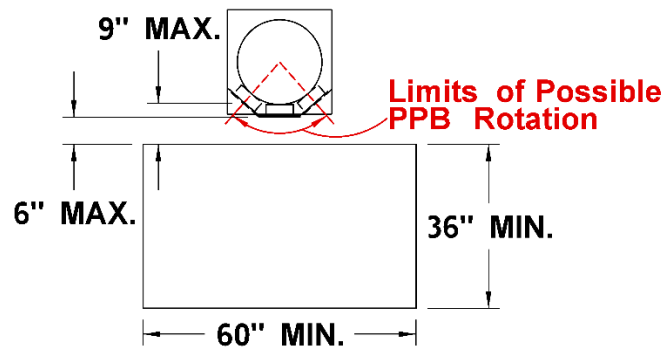
PPBs are required to be located so that the actual button, not just the assembly, is within 9 inches horizontally of a level all-weather surface (generally sidewalk or paved road shoulder) as described in [Chapter 1510](#). To accomplish this, certain criteria must be met depending on the type of pole upon which the pushbutton is installed:

- For vertical shaft poles (Type PPB, PS, I, FB, or RM), the center of the pole shall be no more than 9 inches from the edge of the level clear space. The pushbutton shall not be oriented more than 90 degrees from facing the level clear space. (See [Exhibit 1330-12a](#).)
- For larger signal standards (Type II, III, IV, IV, or SD), the button must face the level clear space, with the edge of the pole baseplate no more than 6 inches from the edge of the level clear space. It is recommended that the pole either be in the sidewalk, or the edge of the pole base plate be installed as close to the back of sidewalk as possible. (See [Exhibit 1330-12b](#).) Some minor rotation of the button on the pole is possible, but even smaller angles may quickly exceed the allowed reach limit – particularly on larger poles.

## Exhibit 1330-12a PPB Placement on Vertical Shaft Poles



## Exhibit 1330-12b PPB Placement on Large Signal Standards



In all cases, it is recommended that the pole be installed in the sidewalk for maximum accessibility. However, the pole and the pushbutton itself are obstructions and must not encroach upon the required minimum pedestrian access route widths (see [Chapter 1510](#)).

PPBs are required to be installed at 42 inches above the level clear space, as measured to the center of the actual button. Existing pushbuttons do not require a height adjustment if the center of the actual button is within a range of 36 to 48 inches above the level clear space.

Where there is a median or center island with a pedestrian refuge, consult with signal operations to determine if a pushbutton should be installed in the pedestrian refuge area. This may be justified for locations with particularly long crossings or slower moving pedestrians.

For WSDOT owned systems, pedestrian signal equipment may not be installed on light standards. Do not install pedestrian signal equipment on light standards for systems owned by other jurisdictions unless directed to do so by that jurisdiction.

#### 1330.04(4)(a) Accessible Pedestrian Signals and Countdown Pedestrian Displays

Accessible Pedestrian Signals consist of a pedestrian pushbutton with integrated vibro-tactile and audible versions of the visual indications presented by pedestrian signal displays. APS are required at any location with a pedestrian display – *even if there was no pedestrian detection previously*. This is due to the requirement to provide non-visual indication of the pedestrian phase. All new construction traffic signals are required to include APS.

Countdown pedestrian displays are displays which use a combination of an overlapping person (walk) and hand (don't walk) indication and an adjacent two digit countdown timer display. The timer counts down the seconds remaining in the pedestrian clearance phase (flashing don't walk). For WSDOT owned traffic signals, all new construction traffic signals are required to include countdown pedestrian displays. For new construction traffic signals owned by other jurisdictions, countdown pedestrian displays are required unless directed otherwise by the owning jurisdiction.

For existing signalized intersections where pedestrian equipment was not previously installed, the installation of APS and countdown pedestrian displays is required for the entire intersection.



This may require new or relocated poles, as well as additional ramp and sidewalk work beyond that necessary for basic sidewalk and ramp ADA compliance.

At signalized intersections with existing pedestrian equipment, the following criteria determine when APS pushbuttons and countdown pedestrian displays shall be installed:

1. The following are considered minor signal upgrades, and do not require the installation of APS pushbuttons or countdown pedestrian displays at that intersection:
  - a. Where pushbuttons are only being adjusted in height or orientation.
  - b. Where pushbuttons are being relocated on a single corner, including to a new pole, and no other work (including sidewalk or ramp work) is taking place at any other corner, pushbuttons may be relocated or replaced with the same type of pushbutton as currently exists at that intersection. Countdown pedestrian displays are not required to be installed at that intersection. New pole location(s) must meet accessibility requirements for pedestrian pushbuttons (see [Chapter 1510.12](#)). Accessibility for any affected poles must be evaluated for both existing pushbuttons and future APS pushbuttons.
2. The following types of work shall include the installation of APS pushbuttons and countdown pedestrian displays as described below:
  - a. At any signalized intersection included in a project that is designated as an alteration project, as defined in [Chapter 1510.05\(2\)](#):
    - i. For WSDOT owned traffic signal systems, install APS pushbuttons and countdown displays. For any project which has completed its scoping phase before August 1, 2018, consult with your ASDE to determine if APS pushbuttons and countdown pedestrian displays can be added to the project – documentation is not required if the project cannot support the expanded scope of work.
    - ii. For traffic signal systems owned by other agencies, install APS pushbuttons and countdown displays if funded by the owning agency.
  - b. At any signalized intersection where APS pushbuttons are being installed in response to a public request, replace all pushbuttons and pedestrian displays with APS pushbuttons and countdown pedestrian displays at that intersection. Additional poles may be required and ramp and sidewalk work may be necessary to support access to new APS locations / orientations.
  - c. For any other project, not previously described, which requires traffic signal system work affecting pedestrian pushbuttons, replace all pushbuttons and pedestrian displays with APS pushbuttons and countdown pedestrian displays. This may require additional ramp and sidewalk work to provide required accessibility to and for APS locations / orientations beyond that already required for other ADA compliance efforts.

APS pushbuttons are required to include the following features:

1. Audible and vibrotactile indications of the WALK interval.
2. A locator tone which operates only during the DON'T WALK and flashing DON'T WALK intervals.

3. A tactile arrow on the pushbutton (control surface) indicating the crossing direction served. This arrow must be high contrast with the rest of the button – either light on dark or dark on light.
4. An integral 9" x 15" R10-3e sign.
5. If additional crossing time will be provided as part of an extended press feature, a supplemental R10-32P sign is required to be installed adjacent to or integral with the APS PPB.

### **1330.04(5) Signal Standards (Supports)**

Signal standards consist of five main types of supports: Vertical Steel Shaft, Cantilevered Steel Mast Arm, Steel Strain Pole, Wood Strain Pole, and Signal Bridge. The type of support selected will depend on required placement of vehicle signal displays and the ability of the support to reach that location. The [MUTCD](#) states that the preferred location for signal displays is overhead on the far side of the intersection.

Signal displays may also be mounted to bridges where clearance will not allow an alternate signal standard type. Installation on bridges requires approval of both the region Traffic Engineer and the HQ Bridge and Structures Office.

Signal Standards shall be considered in the following order of preference:

1. **Cantilevered Steel Mast Arm.** These are the standard support type for permanent systems, and should be used whenever possible. Mast arm installations are preferred because they generally provide better placement of the signal displays, greater stability for signal displays in high-wind areas, and reduced maintenance costs. Mast arm lengths are limited to 65 feet from center of pole to farthest display mount – if additional length is needed, an alternate support type must be used.
2. **Span Wire System (Steel or Wood Strain Poles).** These systems may be used when displays are needed at a greater distance than a mast arm system can support, or if a system is expected to be in place for less than 5 years. Steel poles are required to be used for permanent signal systems. Temporary signal systems (systems to be removed under the same contract as installation) may use wood poles. The use of wood poles beyond the end of a contract or for longer than 5 years requires the approval of the region Traffic Engineer. Individual spans have a limit of 150 feet – longer spans require design by the HQ Bridge and Structures Office.
3. **Signal Bridge.** Signal bridges shall only be used when no other alternative can physically be installed and support displays in the required locations. Diagonal signal bridges are not recommended as they are extremely difficult to maintain and result in displays being too close to at least one of the two cross streets, resulting in poor display visibility. Diagonal spans in general are not recommended as a failure will result in the loss of the entire signal system, rather than just one or two directions.
4. **Vertical Steel Shaft.** Vertical steel shaft supports should only be used for supplemental vehicle displays or pedestrian equipment. In special cases (such as in a small historic town), vertical steel shaft supports may be used without overhead signal displays if approved by the region Traffic Engineer, as allowed by the MUTCD. This practice is not recommended, as displays are too easily obstructed from view.

When placing signal standards, the primary consideration is the visibility of signal faces. Place the signal supports as far as feasible from the edge of the traveled way without adversely affecting signal visibility. (The [MUTCD](#) provides additional guidance on locating signal supports.) Initially, lay out the location for supports for vehicle display systems, pedestrian detection systems, and pedestrian display systems independently to determine the optimal location for each type of support. Consider the need for future right-turn lanes or intersection widening when choosing the final location of the signal standards. Poles should also be located outside of sight triangles for turning traffic.

If conditions allow and optimal locations are not compromised, pedestrian displays and pedestrian detectors can be installed on the vehicular display supports. However, pole placement cannot encroach on pedestrian access route or maneuvering space requirements. Pole mounted appurtenances, such as pushbuttons, terminal cabinets, and displays, need to be taken into consideration regarding their encroachment into accessible spaces.

Another important consideration that can influence the position of signal standards is the presence of overhead and underground utilities. Verify the location of these lines during the preliminary design stage to avoid costly changes during construction:

- a. **Underground Utilities:** Underground utilities must be located, marked, and surveyed. If any underground utility is within 10 feet of any foundation, consider potholing for the utility to find its actual location. Field locates are rarely precise and must be verified if a potential conflict exists.
- b. **Overhead Utilities:** Signal standards may be located within close proximity to overhead communications lines (phone, cable, fiber-optic), but the lines should not touch the any part of the signal system and should not pass in front of any displays. Overhead power lines require a minimum 10-foot circumferential clearance for lines rated at 50kV (50,000 V) or below, including the neutral. For lines rated over 50kV, the minimum clearance is 10 feet plus 0.4 inches for each kV over 50kV. Overhead utilities may have to be relocated if a suitable location for signal equipment cannot be found.

Once pole locations have been selected, a soils investigation is required to determine the lateral bearing pressure, the friction angle of the soil, and whether groundwater may be encountered. Standard foundations may be used if the soil lateral bearing pressure is at least 1,000 psf, the friction angle is at least 17°, and the ground slope is 2H : 1V or flatter. Standard foundation information is found in the [Standard Plans](#), and depends on the type of support system being used.

Special foundation designs are required if the soil lateral bearing pressure is less than 1,000 psf, the friction angle is less than 17°, or the ground slope is steeper than 2H : 1V. The region materials group works with the HQ Materials Laboratory to determine the bearing pressure and friction angle of the soil at the proposed foundation locations. If soils do not meet these minimum values for lateral bearing pressure and friction angle, the signal standard charts and soil conditions report (summary of geotechnical conditions for foundations) must be forwarded to the HQ Bridge and Structures Office with a request for special foundation design. The HQ Bridge and Structures Office designs foundations for the regions and reviews designs submitted by others.

Where poles are installed on structures, the anchorage must be designed by the Bridge designer. Coordinate with the Bridge designer for placement and design of pole anchorages on structures.

Do not place any signal standard in a median area. The sole exception is a Type PS or Type PPB signal standard as required for median refuge areas for pedestrians.

Coordinate with all stakeholders (Maintenance, Signal Operations, Civil Design Engineer, Drainage Engineer, and so on) in the placement of signal equipment to avoid any possible conflicts. Arrange field reviews with the appropriate stakeholders as necessary.

### **1330.04(5)(a) Mast Arm Signal Standards and Foundation Design**

Mast arm signal standards are designated by the following types:

- Type II: Single mast arm with no luminaire mount.
- Type III: Single mast arm with luminaire mount.
- Type SD: Double mast arm, with or without luminaire mount.

Mast arm signal standards are normally located on the far right corner of the intersection from approaching traffic. A typical mast arm signal standard only has one mast arm, however two may be used. If the angle between the two arms is not exactly 90 degrees, the design must be sent to the bridge and structures office. In most cases, two arms at 90 degrees can support the necessary display positioning. Additionally, signal standards on mast arms may be rotated up to 30 degrees from center. Do not allow a mast arm for one direction to cross in front of the mast arm for a different direction if possible, as it results in a visual obstruction of the signal displays. Where two double arm signal standards are installed on opposite corners, the preferred location for the two poles are the far right corners of the mainline roadway. This way, the mast arms for the mainline traffic will not cross in front of each other.

Mast arm signal standards have a typical arm attachment point of 18 to 20 feet in height. This height range needs to be taken into consideration when placing signal displays in order to ensure that the display height requirements shown in [1330.04\(3\)](#) are met. The attachment point height may be adjusted throughout this range as necessary, but increments of 0.5 feet are recommended for ease of fabrication. Connection points outside of this range are a special design, and require design support from the Bridge and Structures Office.

Mast arm signal standards are designed based on the total wind load moment on the mast arm. The moment is a function of the surface area of each appurtenance (signal display or sign),  $X * Y$ , and the distance between the vertical centerline of each appurtenance and the vertical centerline of the signal pole  $Z$ . This determines the total wind load moment, referred to as an XYZ value and measured in cubic feet, which is used to select the appropriate mast arm fabrication plan and foundation design. Preapproved mast arm fabrication plans are available at <http://www.wsdot.wa.gov/Bridge/Structures/LSS.htm>, and will be listed in the Contract Provisions. To determine the XYZ value for a signal standard, the XYZ value of each appurtenance must be calculated. These values are then totaled to determine the overall XYZ value for the signal standard. For signal standards with two mast arms at 90 degrees apart, the larger of the two XYZ values calculated for each mast arm is used for the overall pole XYZ value.

When determining the XYZ values, use the worst-case scenarios for signal display and sign placements. All signal displays and mast arm-mounted signs, including street name signs, must be included in this calculation. Emergency preemption detectors, preemption indicator lights, cameras, and radar detectors are negligible and are not included in determining the XYZ values. For mast arm-mounted signs, use the actual sign area (in square feet) to determine the XYZ value. For poles with luminaire supports, the luminaire and arm is also included in the total XYZ

calculation. Surface areas for vehicle displays are shown in [Exhibit 1330-13](#). Signs are limited in size as follows:

- Street name signs may be a maximum of 36 inches in height and 36 square feet in total area. Design the mast arm to support the widest sign that will fit within these limits (up to 144 inches wide), regardless of the actual sign size needed. This allows for future changes to the street name sign. Street name signs are mounted such that the edge of the pole is no less than 1 foot but no more than 2.5 feet from the vertical pole centerline, as shown in the [Standard Plans](#). Use the offset necessary for the largest possible sign in the signal standard chart for the XYZ value, but refer to the [Standard Plans](#) for actual sign installation requirements using construction notes in the Contract Plans.
- Other mast arm mounted signs may not exceed 36 inches in height and 7.5 square feet in area.
- Signs mounted on the vertical pole may not exceed 36 inches in width and 15 square feet in area. These signs are not included in the XYZ calculation.

After calculating the total XYZ value, adjust the total XYZ value as follows:

If the total XYZ value is less than or equal to 2850 ft<sup>3</sup>, round the XYZ value up to the next standard foundation XYZ value or 2850 ft<sup>3</sup>, whichever is lower, to determine the design XYZ value. The design XYZ builds in some flexibility for future modifications.

- If the total XYZ value exceeds 2850 ft<sup>3</sup>, use the calculated XYZ value. There is limited opportunity for future increased wind load when the XYZ value exceeds 2850 ft<sup>3</sup>.

#### **Exhibit 1330-13 Signal Display Surface Areas**

Signal Display	Area
Vertical 3-section	9.2 sq ft
Vertical 4-section	11.6 sq ft
Vertical 5-section	14.1 sq ft
5-section cluster	14.4 sq ft

After the total XYZ value is determined, if a standard foundation may be used, select the correct foundation depths for the XYZ values from the table in the [Standard Plans](#), using the next higher total XYZ value. For WSDOT systems, only the 700, 1350, 1900, 2600, and 3000 columns may be used. All five foundation options should be provided unless there is a known constraint preventing the use of one of the options, such as insufficient space for 4 ft diameter foundation or expected loose soil requiring the use of the Alternate 2 foundation construction.

#### **1330.04(5)(b) Span Wire Signal Standards and Foundation Design**

Span Wire Systems use poles and aerial wires to support signal displays, signs, and emergency preemption equipment. Cameras, radar detectors, and street name signs are installed on the vertical strain poles. When laying out span wires, the preferred layout is similar to mast arm supports. Displays for an approach should be installed on a span on the far side of the

intersection, with poles on the two far corners. Do not use diagonal spans unless absolutely necessary, as they are extremely difficult to maintain and if the wire is broken, the entire signal system is lost and blocks the entire intersection, rather than the equipment for only one approach.

Span wire signal standards include both steel and timber strain poles. Steel and timber strain poles are designated by pole class, which is based on the horizontal tension load the pole will support. The loads and resultant forces imposed on strain poles are calculated and a pole class greater than that load is specified. Steel Pole Classes and their allowed tension loads are listed in the *Standard Plans*. [Exhibit 1330-14](#) lists the pole classes and tension loading available for timber strain poles.

Headquarters Traffic and Headquarters Bridge and Structures office support is required for determining span tension load and pole classes. Provide the pole and span layout, the locations and sizes of all signal displays and span wire mounted signs, and the soils report. Span wire mounted signs are limited to a maximum of 36 inches in height and 7.5 square feet in area. Emergency preemption equipment locations do not need to be submitted, as they are not included in load calculations. Spans should not exceed 150 feet, if possible, in order to reduce the complexity of the design.

After the pole classes are provided by the Headquarters Bridge and Structures office, select the appropriate foundation information from the *Standard Plans* using the pole classes and soil conditions. If a standard foundation cannot be used, a foundation design will be provided along with the pole class information.

#### **Exhibit 1330-14 Timber Strain Pole Classes**

<b>Pole Class</b>	<b>Tension Load Limit (lbs)</b>
4	2400
3	3000
2	3700
1	4500
H1	5400
H2	6400
H3	7500

Pole Classes from ANSI Standard O5.1

#### **1330.04(5)(c) Special Case Signal Supports**

Special case signal supports include signal bridges and structure (typically bridge) mounts. These should only be selected if absolutely necessary, as they are difficult to design, construct, and maintain, and they frequently result in signal display locations that are difficult for drivers to see. Use of these types of supports requires approval from the Headquarters Traffic Office.

Signal bridges function the same as a diagonal span wire system, with the two supports on opposite corners of the intersection. Signal bridges require windload calculations similar to mast arm signal standards, so display and sign locations and offsets must be provided. Signal bridge foundations must be designed by the Headquarters Bridge and Structures office.

Signal displays and other equipment may be installed on structures when there is insufficient clearance below the structure to allow for a different type of signal support. Coordinate with the Bridge designer to place mounts and determine routing paths for conduit and wiring out of the structure. Structure mounts are not desirable, as they typically cannot be modified without reconstruction of the structure itself, and any equipment embedded in the structure is inaccessible after the structure is complete.

Signal displays may not be installed on sign structures such as cantilever sign structures or sign bridges. Signal displays also may not be installed on railroad cantilever structures unless the signal system and the railroad are owned by the same jurisdiction and maintained by the same staff.

#### **1330.04(5)(d) Vertical Steel Shaft Supports**

Vertical steel shaft supports include the following types of signal standards:

- (a) Type PPB: Sometimes referred to as a “stub pole”, this pole is typically 5 feet tall and 3 inches in diameter. It is used strictly to support pedestrian pushbuttons. Due to the frequency of damage, regardless of location, it is recommended that breakaway bases always be used.
- (b) Type PS, I, RM, and FB: These poles are effectively identical, with the difference being the total height to the slipfitter top.
  - Type PS are 8 ft tall and may only have pedestrian displays mounted on the top.
  - Type I are 10 ft tall and may have vehicle displays mounted on the top and pedestrian displays mounted on the side. Type RM are identical to Type I but are used for ramp meter systems only.
  - Type FB are 14 feet tall, and may be used like Type I when additional height is needed for the vehicle display(s).

Placement of vertical steel shaft supports will depend on visibility requirements for displays and accessibility requirements of pedestrian features. Generally, these supports should be located at back of sidewalk, as they are farther from traffic and more likely to be out of both the pedestrian access route and the path of any users. Fixed bases should be used when located at the back of sidewalk, but slip bases may be used if circumstances recommend it. Supports located within sidewalk (includes planter strips) or in locations with only paved shoulders should always use slip bases.

#### **1330.04(6) Vehicle Detection Systems**

Vehicle detection systems are necessary for the efficient operation of traffic signals. By responding to the presence of traffic, signal systems do not have to use fixed timing. This improves efficiency by removing unnecessary delay and not providing service to an approach or movement with no traffic.



### 1330.04(6)(a) Vehicle Detection Zone Placement

The detection system at a traffic-actuated signal installation provides the control unit with information regarding the presence or movement of vehicles, bicycles, and pedestrians. Vehicle detection systems perform two basic functions: queue clearance and the termination of phases. Depending on the specific intersection characteristics, either of these functions can take priority. The merits of each function are considered and a compromise might be necessary.

There are two basic types of detection zones: stop bar and advance. Stop bar detection is a zone that extends from the stop line to a point 30 to 40 feet in advance of that location. Advance detection is a discrete zone (or zones) placed in advance of the stop line at a distance dependent on vehicle speed.

Basic vehicle detection requirements depend upon the speeds of the approaching vehicles:

- (a) When the posted speed is below 35 mph, provide stop bar detection or one advance detection zone. See [Exhibit 1330-15](#) for advance detection zone distances.
- (b) When the posted speed is at or above 35 MPH, provide stop bar detection and at least two advance detection zones. Multiple advance detection zones are normally required to accommodate decision zone detection.
- (c) Side street advance detection is not required for WSDOT owned signal systems, but may be provided through means that do not require equipment to be installed off of WSDOT right of way. For signals owned by other jurisdictions, the use of side street advance detection is at the discretion of the owning jurisdiction.

A decision zone is a location along the intersection approach where a motorist is forced to make a decision between two alternatives. As applied to vehicle detection design, this situation can occur when two vehicles are approaching a traffic signal and the signal indication turns yellow. The motorist in each vehicle must decide whether to continue through the intersection or stop prior to the intersection. If the lead vehicle decides to brake and the following vehicle does not, there may be a rear-end crash.

For posted speeds of 35 MPH or higher, there are two options for placing advance detectors to address the decision zone:

1. Fixed locations based on posted speed, which is generally the 85th percentile speed. Place loops according to the table in [Exhibit 1330-15](#).
2. Calculated locations based on calculated decision zone detection design. This design increases the opportunity for a range of vehicles from the 90th percentile speed vehicle to the 10th percentile speed vehicle to either clear the intersection or decelerate to a complete stop before reaching the intersection. The method of calculating the decision zone and the required detection loops is shown in [Exhibit 1330-16](#).

Although the exhibits reference loops, advance detectors may be of any approved type.

For new intersection construction where there is no existing traffic, the fixed locations based on posted (target design) speed are to be used. Fixed locations based on posted speed use the same methods as the calculated decision zone detection design, but set V90 at 5 MPH above posted speed and V10 at 5 MPH below posted speed. Engineering judgment based on similar intersections (such as geometrics and traffic volumes) may justify modifying the V90 and V10 speeds used in the calculation, with concurrence from the region Signal Operations Engineer.



Both methods require a study of the approach speeds at the intersection. For intersection approaches, conduct the speed study as follows:

- Collect data at the approximate location or just upstream of the decision zone;
- Collect data during off-peak hours in free-flow and favorable weather conditions;
- Collect data during regular commuting hours in a high volume signalized corridor during favorable weather conditions
- Only document the speed of the lead vehicle in each platoon.

It is important that the person conducting the speed study remain inconspicuous so they do not influence drivers to slow down. Normal driving patterns are needed for proper speed studies. Prior speed-study information obtained at this location may be used if it is less than 18 months old and driving conditions have not changed significantly in the area.

Preserve detection zone placements and any supporting calculations as required by [1330.07](#) Documentation.

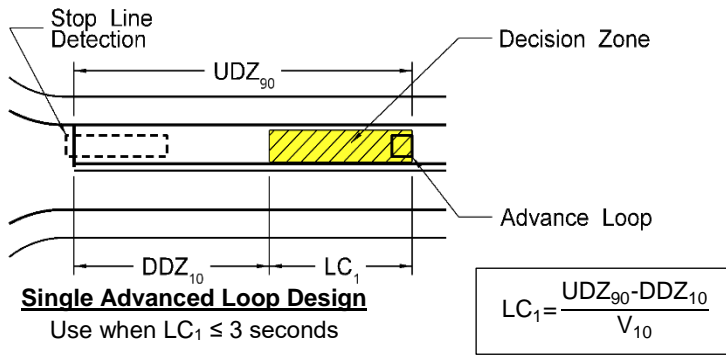
#### Exhibit 1330-15 Fixed Vehicle Detection Placement

Fixed Detection Placement – Below 35 MPH											Calculated	Rounded
V <sub>85</sub> =		V <sub>90</sub> =		V <sub>10</sub> =		UDZ <sub>90</sub>	DDZ <sub>10</sub>	LC <sub>1</sub>	P <sub>MID</sub>	LC <sub>2</sub>	Loop 1	Loop 1
MPH	ft/s	MPH	ft/s	MPH	ft/s	ft	ft	s	ft	s	ft	ft
25	36.7	30	44.00	20	29.33	165.00	50.84	3.9	107.92	1.9	107.92	105
30	44	35	51.33	25	36.67	216.03	70.28	4	143.15	2	143.15	140

For posted speeds below 35 MPH, only the PMID detection location is used.

Fixed Detection Placement – 35 MPH and Above											Calculated		Rounded	
V <sub>85</sub> =		V <sub>90</sub> =		V <sub>10</sub> =		UDZ <sub>90</sub>	DDZ <sub>10</sub>	LC <sub>1</sub>	P <sub>MID</sub>	LC <sub>2</sub>	Loop 1	Loop 2	Loop 1	Loop 2
MPH	ft/s	MPH	ft/s	MPH	ft/s	ft	ft	s	ft	s	ft	ft	ft	ft
35	51.33	40	58.67	30	44.00	273.78	92.40	4.1	183.09	2.1	183.09	273.78	180	275
40	58.67	45	66.00	35	51.33	338.25	117.21	4.3	227.73	2.2	227.73	338.25	225	340
45	66	50	73.33	40	58.67	409.44	144.71	4.5	277.08	2.3	277.08	409.44	275	410
50	73.33	55	80.67	45	66.00	487.36	174.90	4.7	331.13	2.4	331.13	487.36	330	490
55	80.67	60	88.00	50	73.33	572.00	207.78	5	389.89	2.5	389.89	572.00	385	575
60	88	65	95.33	55	80.67	663.36	243.34	5.2	453.35	2.6	453.35	663.36	450	665

Exhibit 1330-16 Decision Zone Detection Placement



**Decision Zone Endpoint Calculation**

(for all loop arrangements)

Where grades are flatter than +/- 4%:

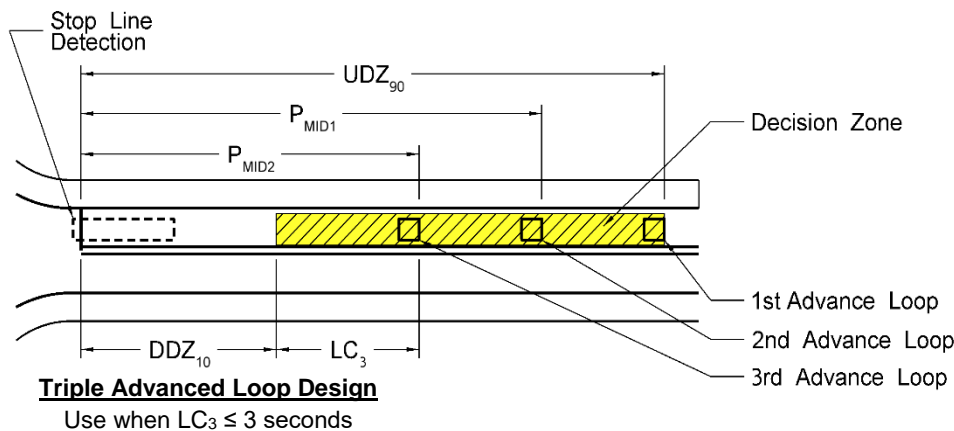
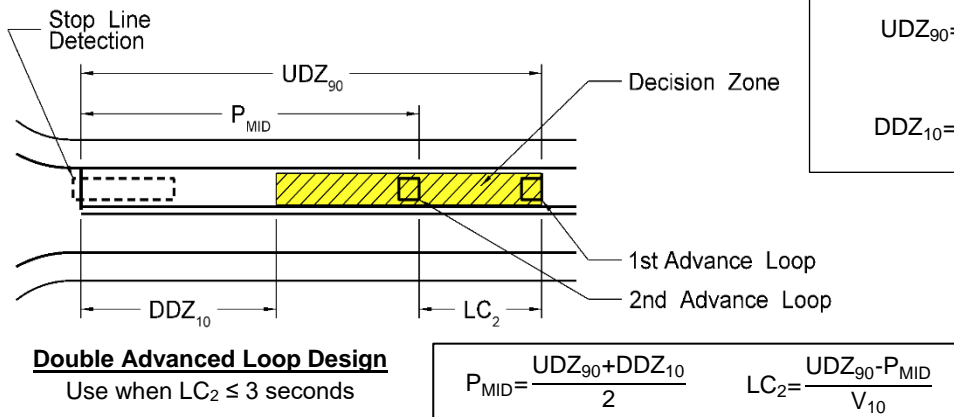
$$UDZ_{90} = \frac{(V_{90})^2}{16} + V_{90}$$

$$DDZ_{10} = \frac{(V_{10})^2}{40} + V_{10}$$

Where grades are +/- 4% or steeper:

$$UDZ_{90} = \frac{(V_{90})^2}{2(8+32.2G)} + V_{90}$$

$$DDZ_{10} = \frac{(V_{10})^2}{2(20+32.2G)} + V_{10}$$



**Where:**

$V_{90}$  = 90<sup>th</sup> percentile speed, in feet per second  
 $V_{10}$  = 10<sup>th</sup> percentile speed, in feet per second  
 $UDZ_{90}$  = Upstream end of decision zone,  
 for 90<sup>th</sup> percentile speed  
 $DDZ_{10}$  = Downstream end of decision zone,  
 for 10<sup>th</sup> percentile speed

$G$  = Grade of roadway, in decimal form,  
 including + or - (Example: -4% = -0.04)  
 $LC_1$  =  $V_{10}$  travel time to  $DDZ_{10}$   
 $LC_2$  =  $V_{10}$  travel time from  $UDZ_{90}$  to  $P_{MID}$   
 $LC_3$  =  $V_{10}$  travel time from  $P_{MID2}$  to  $DDZ_{10}$

### 1330.04(6)(b) Vehicle Detector Types

There are two basic categories of vehicle detectors:

- **Non-Invasive:** These are detectors installed outside of the roadway, typically overhead in a strategic location. These include camera (optical and infra-red) and radar systems.
- **In-Pavement:** These are detectors which are installed in the road itself. These include induction loops and wireless in-pavement sensors.

Non-invasive detection is generally recommended over in-pavement detection, due to the ability to revise non-invasive detection at any time and the ease of installation, repair, and replacement – particularly when supporting traffic control and impacts are taken into account. Additionally, pavement damage due to regular wear or construction activities will disable in-pavement detection, whereas non-invasive detectors will continue to function, and can even be adjusted to accommodate revised lane configurations.

Stop line detection should use non-invasive systems for detection. Although induction loop detectors are typically the most reliable for detecting cars and trucks, they do not consistently detect bicycles and motorcycles. [RCW 47.36.025](#) specifically requires that vehicle-activated traffic control signals be capable of detecting motorcycles and bicycles.

Advanced detection may be either non-invasive or in-pavement, as these improve efficiency of the signal systems but are not as critical as stop line detection. Non-invasive is recommended for posted speeds of 45 MPH or lower, as they are currently only effective for up to about 600 feet from the location of the detector. The advantage is that advance detection can be installed at the intersection, rather than trenching long distances to place advanced detectors in pavement. For speeds over 45 MPH, non-invasive detection systems may be considered, but in-pavement systems will probably be more effective. Advance detection does not need to detect bicycles.

Selection of detector types will depend on a variety of environmental factors and locations available for placement.

#### 1. Radar Detectors

Radar detectors are located on either the signal mast arms or the signal vertical strain poles, depending on lane configuration, detector type, and location availability. Radar detectors are not affected by weather, and are typically minimally affected by mast arm motion in high wind. Consult the detector manufacturer's installation guidance for placement details. One detector can normally cover all lanes of an approach for that type of detection (stop line or advance).

#### 2. Video Detectors

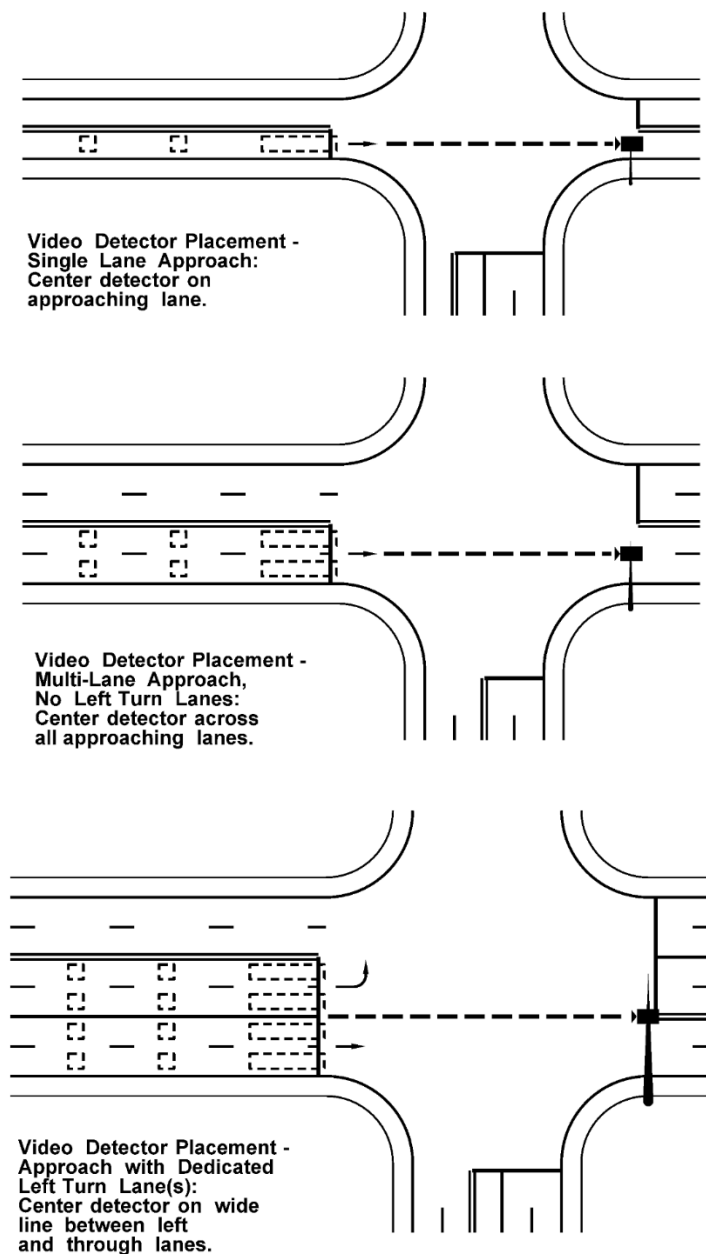
Placement of video detectors depends on the function of the detector. [Exhibit 1330-17](#) provides placement examples.

Stop line detectors should be installed on the same mast arm as the vehicle displays for that approach. The detector should be placed on an extension of the wide line between the left turn and through lanes, if present; if there is no wide line, the detector should be centered on the through lanes. One detector can cover all lanes of an approach for that type of detection (stop line or advance).

Advance detectors should be installed on a luminaire arm, preferably on the adjacent corner to the approaching lanes, as the effectiveness of the advance detection depends on height. Consider requiring a luminaire arm even if no luminaire is needed, in order to provide an optimal installation site for the detector. Advance detectors may be installed on a mast arm, but will typically have less effective range.

Both infra-red and optical cameras are available, but optical cameras are not recommended due to the adverse effects of rain, snow, fog, sun glare, and sharp shadows on their effectiveness. However, infra-red cameras may still be affected by heavy fog or other major thermal events. All video detection may be affected by mast arm motion due to high winds.

**Exhibit 1330-17 Video Detector Placement**



### 3. Induction Loops

Induction Loops are coils of wire in the roadway that use the magnetic properties of vehicles to detect them. Induction loops can last a very long time when undisturbed. However, induction loops require bicycles to be in a very specific location in order to be detected, and may not detect carbon fiber bicycles. Induction loops must be installed with one per lane per detection zone – stop line loops may be larger or series loops. Where induction loops are used, loops need to be numbered in order to keep track of the wiring and lanes they are detecting. See [1330.04\(2\)](#) for detector numbering requirements.

### 4. Wireless In-Pavement Sensors

Wireless in-pavement sensors are compact detectors installed in pavement, and use either radar or magnetics to detect vehicles. They use a wireless connection to the signal cabinet. The sensors rely on a battery for operation, and require replacement of the entire unit when they fail. Sensor placement is similar to induction loops – one per lane per detection zone. The magnetic versions are subject to the same difficulties with bicycles as loop detectors. All wireless sensors are also subject to various factors that affect wireless signals such as range, signal obstructions, and possible signal interference from other radios depending on the frequency used.

Non-invasive detectors are preferred with concrete (Portland cement concrete pavement) roadway surfaces. In-pavement detectors installed in concrete panels typically cannot be revised or replaced until all affected concrete panels are replaced. In-pavement detectors installed in bridge decks must be installed when the bridge deck is constructed, and cannot be replaced unless the bridge deck is replaced. Non-invasive detection is also useful for approaches where advance detection is desired, but the approach is outside the jurisdiction of the agency that owns the signal, or for non-standard approaches such as driveways.

Temporary detection should be installed for all stop lines where existing detection will be disabled or ineffective (such as lane shifts) during construction. Temporary advance detection is recommended for high speed (45 MPH or higher) approaches where the decision zone detection will be disconnected for an extended period of time. Consult with the Signal Operations Engineer to determine if temporary advance detection should be used. Temporary advance detection zone placement should take into account any temporary speed limit revisions.

## 1330.04(7) *Preemption Systems*

### 1330.04(7)(a) **Emergency Vehicle Preemption**

Emergency vehicle preemption (EVP) is required for all traffic signals unless approved otherwise by the region Traffic Engineer. WSDOT is responsible for installing EVP detection equipment at new and rebuilt signalized intersections on state highways. At existing signalized intersections that do not have EVP detection equipment, or where an emergency service agency requests additional equipment beyond the basic required equipment, the emergency service agency is responsible for all material and installation costs. The emergency service agency is responsible for preemption emitters in all cases.

Optically activated EVP systems are used to ensure compatibility with all area emergency service agency emitters. Approval by the State Traffic Engineer is required for the installation of any other type of emergency vehicle preemption system.

Locate optical detectors facing each approach to the intersection – only one detector per approach – with a clear view of the approaching roadway. Detectors have a cone of vision of approximately 8 degrees, and an effective range of 200 to 2500 feet. Detectors should have an unobstructed view of the approach for a minimum of 1800 feet. Primary detectors are normally installed on the same support as the vehicle displays for that approach. Place the detector between the left turn lane and through lane displays on approaches with left turn lanes, or centered on the approaching lanes where left turn lanes are absent.

When the approach is in a horizontal or vertical curve, or there are other sight obstructions, non-standard placement of the primary detector or additional supplemental detectors may be necessary. Primary detectors may be located on other signal display supports (arms or spans) or vertical strain poles, depending on visibility requirements. Supplemental detectors may also be located on separate Type I or Type FB poles in advance of the intersection. On higher speed roadways, supplemental detectors can provide extended detection range – one mile in advance of the intersection is usually sufficient.

Preserve any documentation associated with the EVP system, including system type selected and any associated agreements or approvals, as required by [1330.07](#) Documentation.

### **1330.04(7)(b) Railroad Preemption**

Railroad preemption is used when a railroad is in close proximity to a signalized intersection. If railroad tracks are within 1/4 mile of a signalized intersection, then a Railroad Crossing Evaluation Team is formed to determine the need (if any) for railroad preemption, interconnection, simultaneous preemption, advanced preemption, and so on. The Railroad Crossing Evaluation Team should consist of region and HQ Signal Design Engineers, region and HQ Signal Operations Engineers, HQ Railroad Liaison, HQ Rail Office representative, region Utilities Engineer, region Traffic Design Engineer, region Maintenance Superintendent, and the affected railroad representative. Where the signal is owned, operated, or maintained by a local agency, a local agency representative should also be included.

The Railroad Crossing Evaluation Team will determine what design considerations are needed at all signalized intersections near railroad crossings. For locations where the railroad tracks are located greater than 500 feet from the signalized intersection, and it can be demonstrated that the 95% maximum queue length(s) will not extend to within 200 feet of the tracks, railroad preemption may be omitted with the approval of the Railroad Crossing Evaluation Team. Include the demonstration and approval in the documentation required by [1330.07](#) Documentation.

Railroad preemption and interconnection are recommended when any of the following conditions occurs:

- The distance from the stop bar to the nearest rail is less than or equal to 200 feet.
- There is no dedicated left turn lane and the distance from the stop bar to the nearest rail is less than or equal to 500 feet.
- The 95% maximum queue lengths from the intersection stop bar are projected to cross the tracks. (Use a queue arrival/departure study or a traffic analysis “micro-simulation model” to determine 95% maximum queue lengths.)
- The 95% maximum queue lengths from the railroad are projected to affect an upstream traffic signal. (Use a queue arrival/departure study or a traffic analysis “micro-simulation model” to determine 95% maximum queue lengths.)

If it is determined that advanced preemption is needed, the HQ and region Signal Operations Engineers will calculate the amount of railroad preemption time required using the [Guide for Determining Time Requirements for Traffic Signal Preemption at Highway-Rail Grade Crossings \(TxDOT Form 2304\)](#).

The addition of a pre-signal is recommended when any of the following conditions occurs:

- The distance from the stop bar to the nearest rail is less than 88 feet but is at least 40 feet. (For reference, the 88 feet is derived from: the longest design vehicle permitted by statute (75 feet) + front overhang (3 feet) + rear overhang (4 feet) + downstream clear storage (6 feet)).
- The distance from the stop bar to the nearest rail is > 88 feet and < 120 feet and there are no gates for the railroad crossing.
- The sight distance triangle in [Chapter 1350, Exhibit 1350-1](#) (Sight Distance at Railroad Crossing), cannot be met, and the railroad crossing does not have active control (lights or gates).

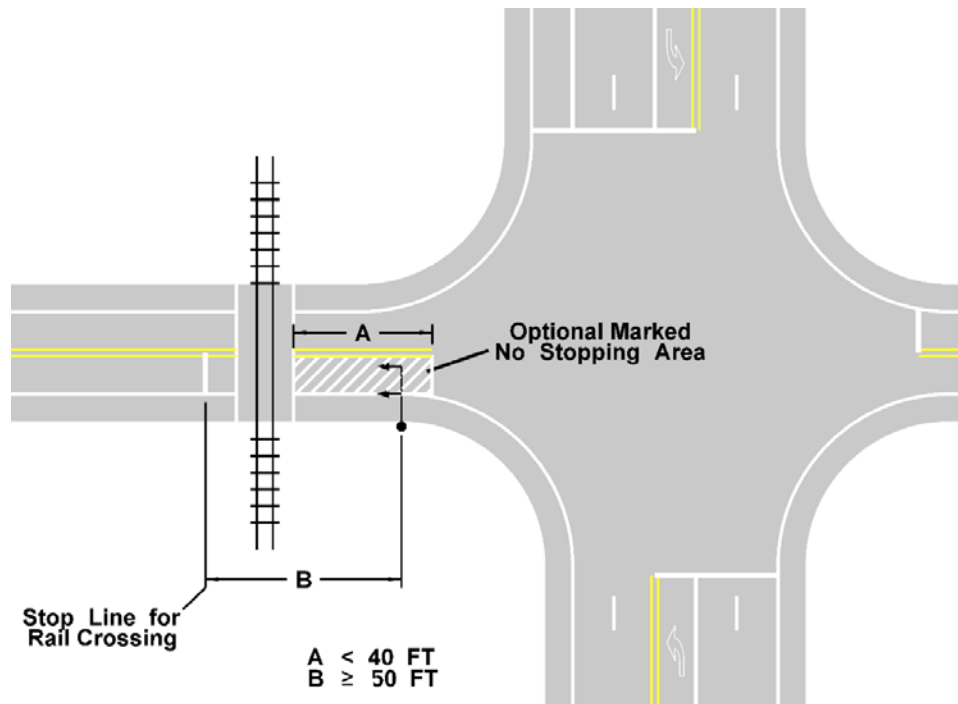
When pre-signals are used, two stop lines are used: one for the rail crossing, and one for the intersection. The pre-signal displays stop traffic at the rail crossing stop line, and the second set of signal displays stop traffic at the intersection. Use louvers on the intersection displays so that they are not visible from the stop line for the rail crossing. Optically programmed displays may be used in place of louvers, but are not recommended due to the limited benefits, complexity of installation and maintenance, and high cost.

Where the distance between the normal location for the stop bar and the approach is less than 40 feet, the same stop bar should be used for both the traffic signal and the rail crossing. Install vehicle displays on the near side of the intersection, but on the far side of the tracks from the stop line, to improve visibility and discourage drivers from stopping between the tracks and the intersection. Do not install vehicle displays on the far side of the intersection.

[Exhibit 1330-18](#) shows examples of the distances and typical system layouts referenced above.

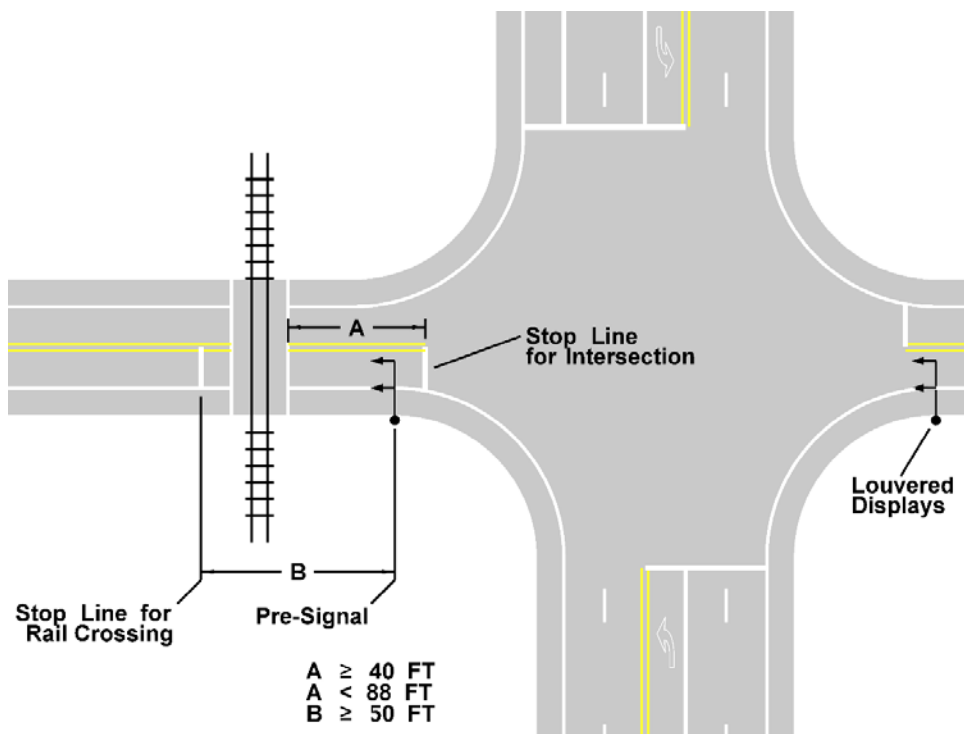
The Railroad Crossing Evaluation Team has final review and approval authority for all PS&E documents for signal design and operation at all signalized intersections near railroad crossings. All documentation associated with railroad preemption and a memo with each team member's concurrence with the PS&E documents must be preserved as required by [1330.07](#) Documentation.

Exhibit 1330-18 Signal Display Layout for Rail Crossings



Display Placement

Less than 40 feet between tracks (dynamic envelope marking) and intersection



Display Placement

40 to 88 feet between tracks and intersection



### 1330.04(7)(c) Transit Priority Preemption

Transit Priority Preemption allows for transit operations to influence signal timing, similar to emergency vehicle preemption. This can be included in mobility projects, but the transit agency assumes all costs for providing, installing, and maintaining this preemption equipment. WSDOT's role is limited to approving preemption operational strategies (phasing, timing, software, and so on) and verifying the compatibility of the transit agency's equipment with the traffic signal control equipment. Preserve all transit priority preemption decisions and agreements as required by [1330.07](#) Documentation.

### 1330.04(8) Control Equipment

The standard WSDOT Signal Controller type for traffic signals is the Type 2070 Controller. Some agencies use National Electrical Manufacturers Association (NEMA) controllers (Type TS1 or TS2). Although not normally used for new construction, WSDOT Ramp Meters and some older systems still use Type 170 Controllers. All traffic signal controllers have the following basic functions:

- Dual ring phase operation
- Eight vehicle phases
- Four pedestrian phases
- Four overlap phases
- Four emergency vehicle preemption channels
- Railroad preemption
- Start and end daylight savings time dates
- Transit preemption (some older controllers may not support this)

Type 2070 controllers and newer NEMA controllers are functionally equivalent for basic signal operations. However, Type 2070 controllers and NEMA controllers use different operating software and communications protocols, and therefore cannot be interconnected together. The type of controller should be specified as follows:

1. For WSDOT traffic signals, specify Type 2070 controllers, unless:
  - a. The signal is interconnected with other signals. If the other controllers in the interconnected system are not being replaced, specify a controller (2070, NEMA, or other) that matches the rest of the interconnected system.
  - b. The signal is operated by another agency. In this case, work with WSDOT and the other agency's maintenance staff to determine the appropriate controller type.
2. For traffic signals owned by other agencies, specify the controller type used by that agency.

The region or operating agency will determine the controller brand and operating software, which are included in the cabinet specifications. Each region or operating agency will provide specifications for their cabinets and the equipment contained therein. For 2070 controllers, double-width cabinets (two racks) should be specified if physically possible to allow for future communications and ITS equipment.

It is often beneficial for one of the agencies to assume responsibility for the operation of the traffic signals. This is accomplished by negotiating an agreement with the other agency. The designer needs to check region policy and make sure someone initiates the process for setting up an operational agreement with the other agency or modifying an existing agreement when applicable. (See the [Agreements Manual](#) for more information on signal systems and maintenance agreements.) At a new intersection, where the state owns the signal, but WSDOT has agreed to let another agency operate the signal, the controller should be compatible with that agency's system. When installing a new controller in an existing interconnected corridor, the controller should be capable of operating with the existing controllers in the corridor. In situations where it is necessary to coordinate the traffic movements with another agency, it is important that the agencies work together.

Intersections within ½ mile of each other on state highways should be interconnected. Perform an operational analysis to determine need for interconnection where intersections are within 1 mile of each other on state highways with a posted speed of 45 MPH or higher. The preferred method for interconnection is fiber optic cable, but other methods such as IP over copper or wireless interconnect may be considered after discussion with maintenance staff and approval by the region Traffic Engineer. Where fiber optic cable is used, it must be routed through pull boxes and cable vaults – bending fiber optic cable through standard junction boxes typically results in the cable being broken. Consider using a separate pull box or vault for coiling the fiber optic interconnect cable to allow for the large-bend radii. Add a construction note in the plans stating to coil additional cable in the adjacent pull box or vault, not the controller cabinet. This will save on space in the controller cabinet and provides additional cable in case an errant vehicle hits the cabinet.

Coordinate with the operations and maintenance staff to determine the optimum controller cabinet location and the cabinet door orientation. The controller cabinet is positioned to provide the best maintenance access and clearest view of the intersection possible. Preferred visibility allows for as many signal displays and roadway approaches visible as possible from a single location. Cabinets should not be placed where they might block the view of turning traffic (intersection sight triangle). If possible, position the controller where it will not be affected by future highway construction.

Cabinets require a minimum of 36 inches of level space in front of each door, including the concrete pad. Do not place cabinets where flooding might occur or where the cabinet might be hit by errant vehicles. If there is a steep down slope or drop off near the cabinet, personnel fall protection (such as fencing) is required in accordance with standards established by the Department of Labor and Industries. Fall protection may not encroach on the required clear space for the cabinet. The location must also have adequate room for a maintenance vehicle to park near the cabinet. Sufficient space for a bucket truck to park is preferable.

If a telephone line (voice or DSL), fiber optic, wireless, or other connection is desired for remote access to the equipment in the cabinet, provide the appropriate equipment in the controller cabinet and/or nearby junction box or cable vault with separate conduits and junction boxes for the remote communications equipment. Communications connections to outside utilities require their own separate conduit and box/vault system.

Consult with maintenance and operations staff to determine if a backup power source, such as an Uninterruptible Power Supply (UPS) or backup generator, is needed for the signal cabinet. Install the backup power supply on the same concrete pad as the signal cabinet. Service and other cabinets may also be installed on the same concrete pad as the signal cabinet (see the

[Standard Plans](#) for concrete cabinet pad layouts). Refer to [Chapter 1040](#) for electrical service types, overcurrent protection, and descriptions and requirements for other components.

### **1330.04(9) Wiring, Conduit, and Junction Boxes**

Consider cost, flexibility, construction requirements, and ease of maintenance when laying out the electrical circuits for the traffic signal system. Consolidate roadway crossings (signal, illumination, ITS conduits, and so on) whenever possible to minimize the number of crossings and take advantage of single crossing construction (joint trenches or consolidated directional boring). Include all electrical design calculations in the Project File.

#### **1330.04(9)(a) System Wiring**

Traffic signal systems use multi-conductor cables to connect most of the equipment. Single conductor cable is limited to cabinet power and street lighting circuits.

The following describes typical WSDOT wire type selection:

- 5c cables for signal displays. One 5c per signal phase may connect the signal cabinet to the terminal cabinet on the pole. Separate 5c cables should connect each signal display to the terminal cabinet. Protected / permissive displays may either use one 7c cable or two 5c cables (one for each phase on the shared display).
- 5c cables for pedestrian displays. Consult with region maintenance to determine if the same 5c cable is used for associated pedestrian detection.
- 3cs cables for emergency preemption detectors.
- 2c cables for induction loop detectors. Shielded cable is not required for modern loop detector cards. Older systems may still need shielded cable (2cs), but it is recommended to replace the loop detector cards instead.
- Manufacturer specified cables for video and radar detectors. Video detectors typically use a combined RG9/5c (#18) cable. Radar detectors typically use proprietary 6c and 8c cables. These cables are roughly the size of 7c cables (for calculating conduit fill).
- Use 2c cables for isolated pedestrian detectors (separate pole from associated pedestrian display). For connecting 4-wire APS units, a 7c cable may be used between the PPB post and the signal pole with the pedestrian display (where the APS control unit is located).

To simplify potential repairs for smaller signal standards (Type FB and smaller), consider routing signal display and detection conductors through terminal cabinets on larger signal standards (Type II and larger) before connecting to smaller signal standards. This reduces the amount of wire which may need to be replaced if a smaller signal standard is knocked down and the wiring damaged.

#### **1330.04(9)(b) Conduit**

Refer to the [Standard Specifications](#) for conduit installation requirements. At existing intersections, where roadway reconstruction is not proposed, conduits are to be placed beyond the paved shoulder or behind existing sidewalks to reduce installation costs. All conduits shall be a minimum of 2 inches in size, with the following exceptions:

1. Conduits entering Type PPB signal standards shall be 1 inch. This may be increased to 1 1/4 inch when two APS PPBs are installed on the same pole.
2. Lighting conduits entering pole foundations (signal or light standards) shall be a minimum of 1 inch. See [Chapter 1040](#) for additional requirements for light standards with slip bases.
3. Conduits entering Type PS, I, RM, and FB poles may be a minimum of 1-inch and a maximum of 2-inch.
4. The conduit for the service grounding electrode conductor may be a minimum of ½-inch.

Install spare conduits at all road crossings. Spare conduits at road crossings should be a minimum of one 3-inch conduit or two 2-inch conduits. Install a minimum 2-inch (preferably 3-inch) spare conduit into the controller cabinet.

It is recommended to use full inch conduit sizes to simplify construction and reduce the different types of conduits required for the system. This helps to provide future capacity and reduce costs through bulk material purchasing. Size all conduits to provide 26% maximum conductor fill for new signal installations. A 40% fill area can be used when installing conductors in existing conduits. (See [Exhibit 1330-19](#) for conduit and signal conductor sizes.)

## Exhibit 1330-19 Conduit and Conductor Sizes

Conduit Sizing Table			
Trade Size	Inside Diam. (inches)	Maximum Fill (inch <sup>2</sup> )	
		26%	40%
1/2"	0.632	0.08	0.13
3/4"	0.836	0.14	0.22
1"	1.063	0.23	0.35
1 1/4"	1.394	0.40	0.61
1 1/2"	1.624	0.54	0.83
2"	2.083	0.89	1.36
2 1/2"	2.489	1.27	1.95
3"	3.09	1.95	3.00
3 1/2"	3.57	2.60	4.00
4"	4.05	3.35	5.15

Conductor Size Table			
Size (AWG)	Area (inch <sup>2</sup> )	Size (AWG)	Area (inch <sup>2</sup> )
# 14 USE	0.021	2cs (# 14)	0.090
# 12 USE	0.026	3cs (# 20)	0.070
# 10 USE	0.033	4cs (# 18)	0.060
# 8 USE	0.056	5c (# 14)	0.140
# 6 USE	0.073	7c (# 14)	0.170
# 4 USE	0.097	10c (# 14)	0.290
# 3 USE	0.113	6pcc (# 19)	0.320
# 2 USE	0.133		

Minimize roadway crossings whenever possible. Usually only three crossings are needed (one main line) for a four-leg intersection, and only two roadway crossings are needed for a T intersection. In most cases, the conduit should cross both the main line and side street from the corner where the controller is located.

Directional boring should normally be used when crossing the state route (main line). Open cut trenching may only be used to install conduits under the following circumstances:

1. Existing roadways where the roadway is being resurfaced.
2. Existing roadways where substantial obstacles under the roadway will be encountered.
3. Where there is insufficient room for jacking or boring pits at the edges of the roadway.

Open cut trenching is not permitted across limited access roadways unless the entire pavement surface is being replaced. Sign or signal bridges may not be used for roadway crossings.

### 1330.04(9)(c) Junction Boxes

Provide junction boxes at the following locations:

- Adjacent to the signal cabinet. A pull box or larger vault may be used in place of multiple junction boxes.
- Adjacent to each signal pole. One box may serve multiple poles. The distance from a pole to the first junction box should not exceed 10 feet without concurrence from maintenance staff. Pole bases may not be used as junction boxes.
- Adjacent to each set of detector loops. These boxes contain the detector loop splices. One box may serve multiple lanes, but the box should be no more than 50 feet from the detector loop.
- At the end of each road crossing.
- In the middle of conduit runs where the number of bends would equal or exceed 360°.

Where possible, locate junction boxes out of paved areas and adjacent to (but not in) sidewalks. New junction boxes may not be placed in the pedestrian curb ramp or ramp landing of a sidewalk. If a new junction box must be placed within sidewalk, locate it at the edge of the sidewalk and designate it to be slip-resistant. Existing junction boxes located within new or existing sidewalk, including ramps or landings, must be revised as follows:

- Existing junction boxes containing power conductors for the traffic signal (not including street lighting), or wiring for the signal displays, may remain in place, even if they will be within a sidewalk ramp or ramp landing.
- Existing junction boxes containing detector wiring may remain in sidewalks, but must be relocated outside of sidewalk ramps and ramp landings. Designate that the relocation work, including conduit adjustments and rewiring, be completed within a single shift or provide temporary detection using another conduit path.
- All junction boxes which will be within sidewalk, sidewalk ramps, or ramp landings, must be slip-resistant junction boxes. This includes replacing existing junction boxes with slip-resistant junction boxes.
- Under no circumstances may a junction box be located in a grade break for a sidewalk ramp. Either the ramp must be redesigned or additional accommodations made in construction to allow for the box to be relocated.

The fundamental principle is that if relocating a junction box requires shutting down a traffic signal system, the junction box may remain in its existing location but must be replaced with a slip-resistant junction box. See [Chapter 1510](#) for additional ADA requirements.

Do not place junction boxes within the traveled way unless absolutely necessary. Make every effort to locate new junction boxes and to relocate existing junction boxes outside the travel lane or paved shoulder. If there is no way to avoid locating the junction box in the traveled way or paved shoulder, heavy-duty junction boxes must be used. Avoid placing junction boxes in areas of poor drainage. Do not place junction boxes within 2 feet of ditch bottoms or drainage areas, or within vegetative filter strips or similar water treatment features which may be

present. The maximum conduit capacities for various types of junction boxes are shown in the [Standard Plans](#).

### 1330.05 Preliminary Signal Plan

Develop a preliminary signal plan for the Project File. Include a brief discussion of the issue that is being addressed by the project. Provide sufficient level of detail on the preliminary signal plan to describe all aspects of the signal installation, including proposed channelization modifications. Use a plan scale of “1 inch = 20 feet” and include:

- (a) Stop lines.
- (b) Crosswalks.
- (c) Sidewalk locations, including curb ramps.
- (d) Guardrail locations.
- (e) Drainage items.
- (f) Left-turn radii, including beginning and ending points.
- (g) Corner radii, including beginning and ending points.
- (h) Vehicle detector locations and proposed detector types, including exclusive bicycle detectors.
- (i) Pedestrian detector (PPB) locations.
- (j) Signal standard types and locations.
- (k) Vehicle signal displays.
- (l) Pedestrian signal displays.
- (m) Phase diagram, including pedestrian movements.
- (n) Emergency vehicle preemption requirements.
- (o) Railroad preemption requirements.
- (p) Illumination treatment, including a calculation summary showing the average light level, average/minimum uniformity ratio, and maximum veiling luminance ratio. (See [Chapter 1040](#) for more information on illumination design requirements.)
- (q) Cabinet locations with door orientations.
- (r) Traffic counts, including left-turn movements.
- (s) Speed study information indicating 90th and 10th percentile speeds for all approaches (if used for detector spacing).
- (t) Utilities information.

Submit a copy of the preliminary signal plan to the State Traffic Engineer for review and comment. Allow two to three weeks for review of the preliminary signal plan. After addressing

all review comments, finalize the plan and preserve as required by [1330.07](#) Documentation. Prepare the contract plans in accordance with the [Plans Preparation Manual](#).

If HQ Traffic Design is preparing the contract Plans, Specifications, and Estimate (PS&E) package for the signal system portion of the project, submit the above preliminary signal plan with the following additional items:

- (u) Contact person.
- (v) Charge numbers.
- (w) Critical project schedule dates.
- (x) Existing and proposed utilities, both underground and overhead.
- (y) Existing intersection layout, if different from the proposed intersection.
- (z) Turning movement traffic counts (peak hour for isolated intersections) and a.m., midday, and p.m. peak-hour counts if there is another intersection within 500 feet.
- (aa) Electrical service location, source of power, and utility company connection requirements.

After the PS&E is prepared, the entire package is transmitted to the region for incorporation into its contract documents.

## 1330.06 Operational Considerations for Design

This section describes operational guidance for traffic signals. These operational requirements will directly affect the design of the traffic signal, particularly in regards to signal display types and locations.

All traffic signals should be periodically re-evaluated, to determine if timing or phasing changes would result in more efficient operation of the traffic signal, or in the case of interconnected systems, the corridor or network. Changes in traffic volumes, posted speeds, or other factors may influence turning movement phasing operations (protected, protected/permissive, or permissive), green times, yellow change intervals, and other operational parameters.

### 1330.06(1) Left-Turn Phasing

Left-turn phasing can either be permissive, protected/permissive, or protected. It is not necessary that the left-turn mode for an approach be the same throughout the day. Varying the left-turn mode on an approach among the permissive only, protected/permissive, and protected-only left-turn modes during different periods of the day is acceptable. Examples are included in the phase diagrams shown in [Exhibit 1330-20](#) and [Exhibit 1330-21](#).

For permissive left turns, the permissive left turn phase shall not terminate separately from the conflicting phase(s) (typically, the opposing through phase). This is to prevent placing left turning traffic in a yellow trap.

#### 1. Permissive Left-Turn Phasing

Permissive left-turn phasing requires the left-turning vehicle to yield to opposing through traffic and pedestrians. Permissive left-turn phasing is used when the following are true:

- a. Turning volume is minor.



- b. Adequate gaps occur in the opposing through movement.
- c. Adequate sight distance beyond the intersection is provided.

This phasing is more effective on minor streets where providing separate protected turn phasing might cause significant delays to the higher traffic volume on the main street. On single-lane approaches with a posted speed of 45 mph or above, or where sight distance approaching the intersection is limited, channelization should include a separate left-turn storage lane for the permissive movement to reduce the potential for rear-end-type collisions and delay to through movements.

Unless there is a dedicated left-turn lane, do not provide a separate display for permissive left turns. When there is a dedicated left-turn lane, a three-section flashing yellow arrow display (with steady red arrow, steady yellow arrow, and flashing yellow arrow displays) should be used for the left-turn lane, as this provides a more positive indication of the permissive turning movement.

## 2. Protected/Permissive Left-Turn Phasing

Protected/permissive left-turn phasing provides both a protected phase and a permissive phase for the same lane, using the same signal display. Where left-turn phasing will be installed and conditions do not warrant protected-only operation, consider protected/permissive left-turn phasing. Protected/permissive left-turn phasing can result in increased efficiency at some types of intersections, particularly “T” intersections, ramp terminal intersections, and intersections of a two-way street with a one-way street where there are no opposing left-turn movements.

Protected/permissive left-turn phasing is NOT allowed under the following conditions:

- a. For new signals, on an approach where Warrant 7 is met and there are five or more left-turning collisions on that approach included in the warranting collisions. This condition requires protected left turn phasing.
- b. For existing signals, when documentation shows that existing protected left-turn phasing was installed due to left-turn collisions.
- c. When sight distance for left-turning vehicles, as outlined in AASHTO’s *A Policy on the Geometric Design of Highways and City Streets*, cannot be met.
- d. On intersection approaches where the opposing approach has three or more lanes (including right-turn lanes) and either the posted speed limit or 85th percentile speeds for the opposing approach are at or above 45 mph.
- e. On intersection approaches that have dual left-turn lanes, including approaches with left only and through-left lanes.

Where there is a separate left-turn lane, protective/permissive displays may use either of the following display arrangements:

- A dedicated four-section arrow display, with steady red arrow, steady yellow arrow, flashing yellow arrow, and steady green arrow displays (four-section FYA). A three-section display with a bi-modal flashing yellow arrow / steady green arrow may only be used if the signal support cannot accommodate a four-section signal display.

- A shared five-section cluster (doghouse) display, placed over the wide line between the left turn lane and the adjacent through lane.

Where there is no separate left-turn lane, only a five-section vertical (recommended) or cluster display may be used. The five-section display is used in place of the left of the two required through displays for that approach.

Protected/permissive displays may run as lead or lag. The display cycle will depend on the display type and whether the protected left leads or lags:

- Leading 4-section FYA: steady green arrow, steady yellow arrow, steady red arrow, flashing yellow arrow, steady yellow arrow, steady red arrow.
- Leading 5-section: green arrow, yellow arrow, red ball, green ball, yellow ball, red ball. Option: green ball may come up with green arrow, but the arrow and ball displays should cycle to yellow and red together (similar to lagging 5-section)
- Lagging 4-section FYA: flashing yellow arrow, steady green arrow, steady yellow arrow, steady red arrow
- Lagging 5-section: green ball, green ball with green arrow, yellow ball with yellow arrow, red.

### 3. Protected Left-Turn Phasing

Protected left-turn phasing provides the left-turning vehicle a separate phase, and conflicting movements are required to stop.

Use protected left-turn phasing under the following conditions:

- a. Multi-lane left turn movements, including left and through-left from the same approach.
- b. The left-turn is onto a roadway with a rail crossing.
- c. Where Warrant 7 is met and there are five or more left-turning collisions on that approach included in the warranting collisions. Protected left-turn phasing is recommended even when there are as few as three left-turning collisions on that approach. This includes left-turning collisions involving pedestrians.
- d. Where the peak-hour turning volume exceeds the storage capacity of the left-turn lane and one or more of the following conditions is present:
  - i. The posted speed or the 85th percentile speed of the opposing traffic is 45 mph or higher.
  - ii. The sight distance to oncoming traffic is less than 250 feet when the posted or 85th percentile speed is 35 mph or below, or less than 400 feet when the posted or 85th percentile speed is above 35 mph.
  - iii. The left-turn movement crosses three or more lanes (including right-turn lanes) of opposing traffic.
  - iv. Geometry or channelization is confusing, such as skewed intersections, offset-T intersections, or intersections which require unusual maneuvers to traverse.

There are three typical operational arrangements for protected left turns:

- **Leading Lefts:** The left turns are served before the associated through movements. This is the most common operational arrangement. Example: Phases 1 and 5 (major street lefts) are served first, then phases 2 and 6 (major street throughs) are served.
- **Lagging Lefts:** The left turns are served after the associated through movements. Example: Phases 4 and 8 (minor street throughs) are served first, then phases 3 and 7 (minor street lefts) are served.
- **Offset (or Lead/Lag) Lefts:** One left turn is served before the associated through movements, and the opposing left turn is served after the associated through movements. Example: Phase 1 (one major left turn) is served first (phase 6 may be served at the same time), then phases 2 and 6 (major throughs) are served, and then phase 5 (opposing major left turn) is served (phase 2 may still be served with phase 5).

Check that all turning movements provide turning clearance for opposing turn phases. If the opposing left-turning vehicle paths do not have 4-foot minimum—12-foot desirable—separation between them, split or offset (lead/lag) phasing will have to be used.

### **1330.06(2) Right-Turn Phasing**

Right turns typically do not operate with their own phasing unless there is a dedicated right turn lane. When there is no dedicated right turn lane, right turns are normally a permissive movement from the right most through lane, depending on pedestrian phases in use. When there is a dedicated right turn lane, right-turn phasing effectively operates the same as left-turn phasing.

Dedicated right turn lanes may be operated the same as left turn lanes: permissive, protected/permissive, or protected. However, right turn phase operation needs to take into account any pedestrian crossing on the receiving side of the right turn. If there is a conflicting pedestrian phase – typically a pedestrian phase running concurrent with the through phase from which the right turn is being made – the right turn phase may only be operated as permissive.

Dedicated right turn lanes operated as permissive and protected/permissive are recommended to have their own displays, but may use a shared display with the adjacent through lane. Dedicated right turn lanes operated as protected must use their own display. Right turn displays are arranged and operated the same as those listed for left turns in [1330.06\(1\)](#). As with left turns, a permissive right turn phase shall not terminate separately from the conflicting phase(s) (typically, the opposing through phase).

Separate right turn phasing also needs to consider some additional operational modes and issues:

#### **1. Right-Turn Overlapped Phasing**

A right turn overlap is when a protected right turn is allowed at the same time as a complementary protected left turn, and is recommended when the lane and phase configuration will support this operation. When this operation is used, the left turn must be signed that U-turns are prohibited.

When right turn overlaps are used, the wiring of the right turn displays will depend on the operating mode of each display section:

- Permissive: Connect permissive display sections to the same terminals as the associated through phase.
- Protected: Protected display sections may either be:
  - (a) Connected to the complementary left turn phase. Use this arrangement when the protected right turn will only be run concurrent with the complementary left turn phase.
  - (b) Connected to an overlap phase. Use this arrangement when the protected right turn will be run with both the complementary left turn phase and with the through phase associated with the right turn.





## 2. Multiple-Lane Right-Turn Phasing

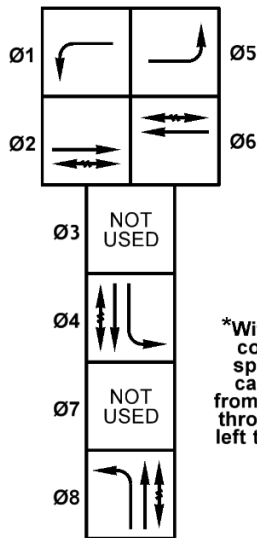
Multiple-lane right turns may be run independent or overlapped as described above. Multiple-lane right turns can cause operational challenges when “right turn on red” is permitted at the intersection. Verify that there is adequate sight distance and adequate receiving lanes are available to minimize the possibility of collisions. In most cases, a single unrestricted “right-turn-only” lane approach with a separate receiving lane (auxiliary lane) will have a similar capacity as the two lane right-turn phasing.

### **1330.06(3) Typical Signal Phasing Arrangements**

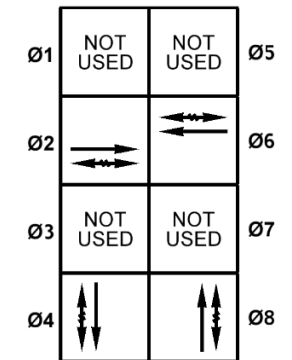
The following diagrams show typical phasing diagrams for four-way and three-way intersections.

Exhibit 1330-20 Phase Diagrams: Four-Way Intersections

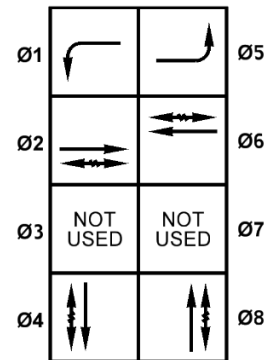
- LEGEND**
-  Protected Vehicle Movement
  -  Overlap (Protected) Vehicle Movement
  - (A)  Overlap Phase Letter
  -  Protected Pedestrian Movement



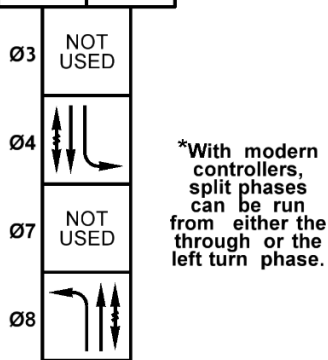
**Split Phase (Six Phase) Operation\***  
Main Street protected lefts  
Minor Street split - protected lefts with concurrent through



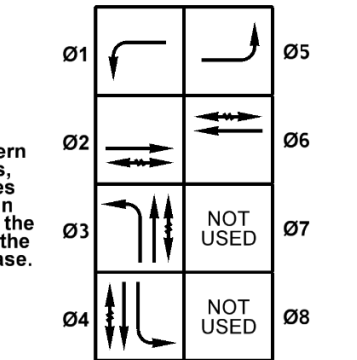
**Basic Four Phase Operation**  
All permissive left turns



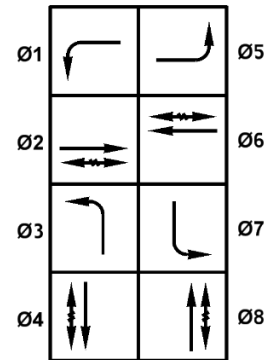
**Six Phase Operation**  
Main Street protected lefts  
Minor Street permissive lefts



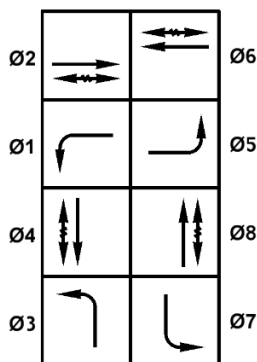
\*With modern controllers, split phases can be run from either the through or the left turn phase.



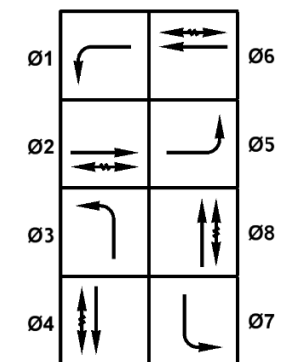
**Split Phase (Six Phase) Operation\* (Alternate Arrangement)**  
Main Street protected lefts  
Minor Street split - protected lefts with concurrent through



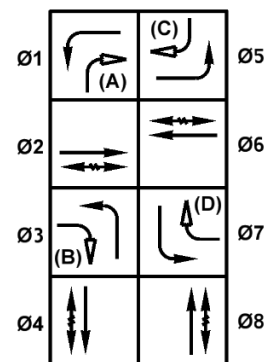
**Eight Phase Operation: Typical**  
Leading protected left turns



**Eight Phase Operation: Lagging Lefts**  
Lagging protected left turns



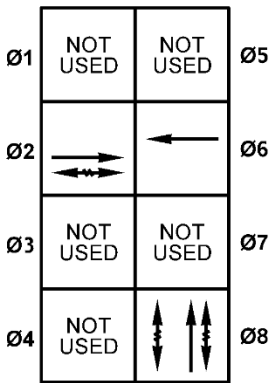
**Eight Phase Operation: Split Lefts**  
Opposing left turns split between leading and lagging



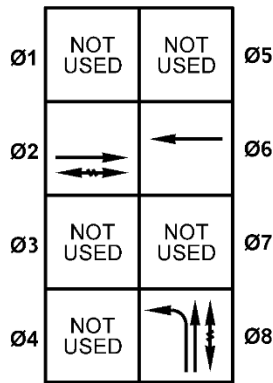
**Eight Phase Operation: Overlaps**  
Leading protected left turns with overlapped protected right turns. Right turns may be permissive with associated through phase.

If right turns are protected with concurrent through phase, negative pedestrian overlaps must be used.

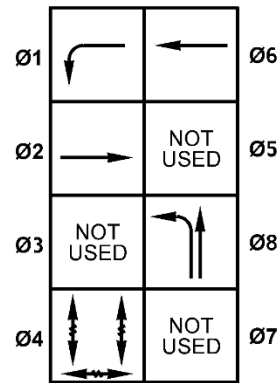
Exhibit 1330-21 Phase Diagrams: Three-Way Intersections



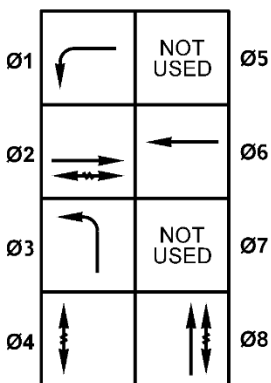
**Basic Three Phase Operation**  
All permissive turns



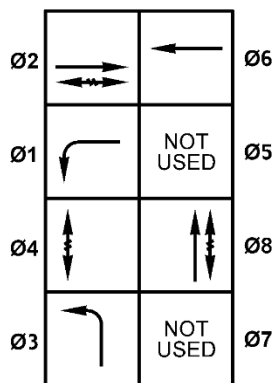
**Three Phase Operation:  
Restricted Peds**  
Protected left turn from side street by removing conflicting pedestrian phase (and crossing)



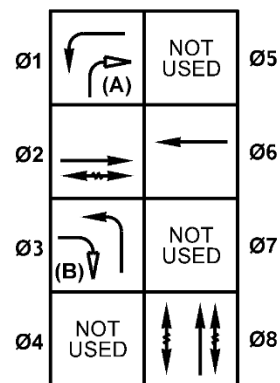
**Five Phase Operation:  
Exclusive Peds**  
All pedestrian crossings run together as separate phase



**Six Phase Operation:  
Typical**  
Leading protected left turns



**Six Phase Operation:  
Lagging Lefts**  
Lagging protected left turns



**Six Phase Operation:  
Overlaps**  
Leading protected left turns with overlapped protected right turns. Right turns may be permissive with associated through phase.

**LEGEND**

- Protected Vehicle Movement
- Overlap (Protected) Vehicle Movement
- (A) Overlap Phase Letter
- ↔ Protected Pedestrian Movement

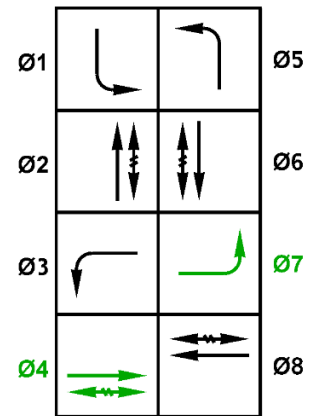
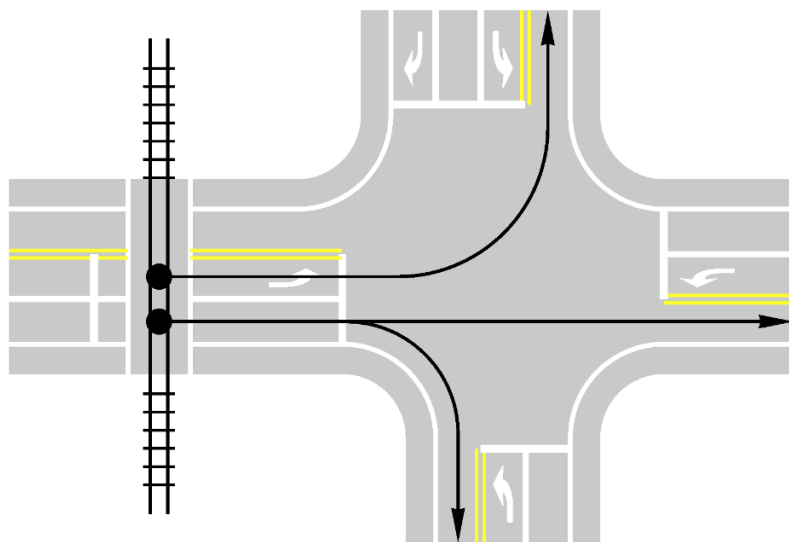
If right turns are protected with concurrent through phase, negative pedestrian overlaps must be used.

### 1330.06(4) Phasing at Railroad Crossings

Traffic signals near railroad crossings have additional special phasing arrangements. To provide for efficient signal operations during a rail crossing, ensure that there are dedicated turn lanes for movements turning onto the tracks. These turn lanes should be on their own dedicated phases, so that they may be omitted from the signal timing (held in red) during the rail crossing. This allows for as many of the other intersection movements as possible to continue to operate – a timing scheme referred to as “Limited Service Operation” (LSO).

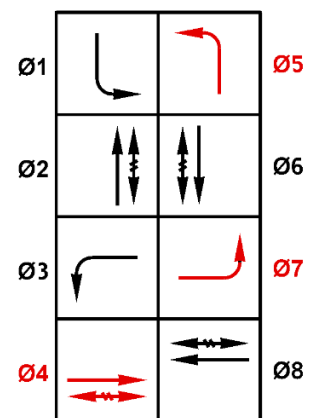
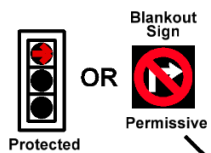
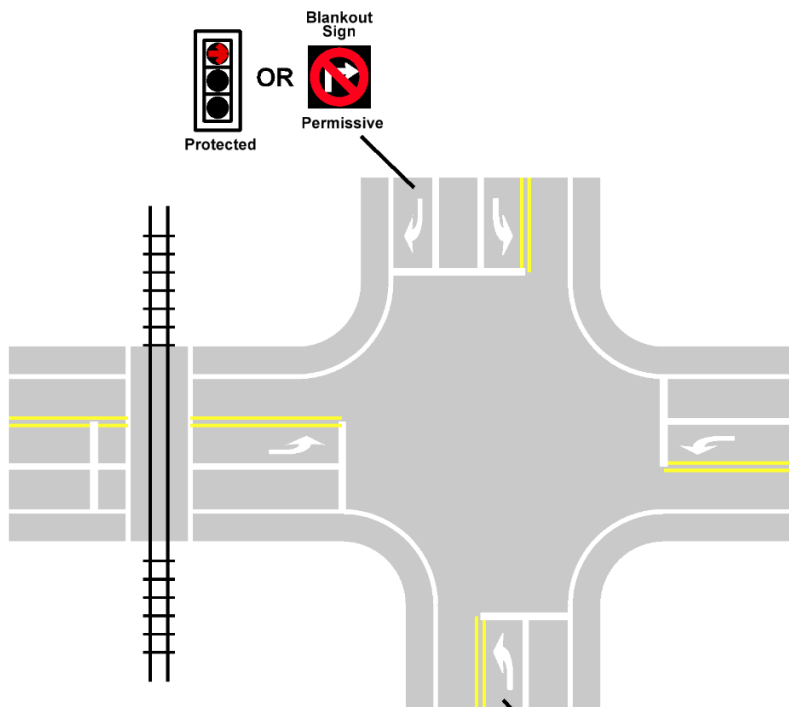
Just prior to LSO, when railroad preemption is used, the traffic signal will shift to a “Track Clearance Green” (TCG) phase. TCG shifts non-conflicting phases to green to allow vehicles to clear the railroad tracks. Examples of a TCG phase and LSO are shown in [Exhibit 1330-22](#). Standalone queue cutter signals do not have a TCG phase – contact the HQ Traffic Office for operational guidance on standalone queue cutter signals.

Exhibit 1330-22 Phasing at Railroad Crossings

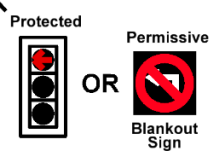


Track Clearance Green Phase(s): Phases 4 and 7

Track Clearance Green



Limited Service Operation: Phases 4, 5, 7, and right turn on phase 6 restricted



Limited Service Operation



### 1330.06(5) Accessible Pedestrian Signals (APS)

APS are required to be operated as follows:

1. All APS at an intersection must use either rapid tick or speech messages – mixed operations at a single intersection are not allowed.
2. Street names in speech messages shall be limited to the basic street name. Do not include cardinals (N, S, E, etc.) or street type (street, avenue, road, etc.) unless needed to avoid confusion where two streets have the same name, such as 2nd Avenue and 2nd Street or Center Drive at Center Way.
3. Walk messages shall be in the format “Walk sign is on to cross <street>”.
4. Button press messages during flashing or solid DON’T WALK phases shall be in the following formats:
  - a. Short press: “Wait”.
  - b. Long press: “Wait to cross <street1> at <street2>”. Street names shall use the same format described above.
  - c. Long press with extended crossing time: “Wait to cross <street1> at <street2> with extended crossing time”.
5. Audible countdowns shall not be used. The APS shall default to the locator tone during any phase other than WALK.

### 1330.07 Documentation

The following original signal design documents shall be included in a Signal System file and provided to the region Traffic Office or owning agency:

1. Signal Permit, including Signal Warrant Analysis and supporting documentation.
2. FHWA Approval for Experimentation.
3. Signal Standard Design Chart, including signal support engineering calculations.
4. Signal Detection Zone Placement. Include calculations if used.
5. Signal Wiring Diagram and Conduit Fill calculations.
6. Railroad preemption calculation and interconnect setup.
7. Any third party documentation provided.
8. Approved Preliminary Signal Plan.
9. Emergency Preemption Equipment selected.
10. Transit Priority Preemption and associated agreements.

Copies of items 1 and 2 are also required to be included in the DDP. Copies of items 3 through 10 are also required to be included in the Project File (PF).

Refer to [Chapter 300](#) for additional design documentation requirements.

## 1330.08 References

The following references are used in the planning, design, construction, and operation of traffic control signals installed on state highways. The RCWs noted are specific state laws concerning traffic control signals, and conformance to these statutes is required.

### 1330.08(1) *Federal/State Laws and Codes*

Americans with Disabilities Act of 1990 (ADA) (28 CFR Part 35)

[Revised Code of Washington \(RCW\) 35.77](#), Streets – Planning, establishment, construction, and maintenance

[RCW 46.04.450](#), Railroad sign or signal

[RCW 46.04.600](#), Traffic control signal

[RCW 46.04.62250](#), Signal preemption device

[RCW 46.61.050](#), Obedience to and required traffic control devices

[RCW 46.61.055](#), Traffic control signal legend

[RCW 46.61.060](#), Pedestrian control signals

[RCW 46.61.065](#), Flashing signals

[RCW 46.61.070](#), Lane-direction-control signals

[RCW 46.61.072](#), Special traffic control signals – Legend

[RCW 46.61.075](#), Display of unauthorized signs, signals, or markings

[RCW 46.61.080](#), Interference with official traffic-control devices or railroad signs or signals

[RCW 46.61.085](#), Traffic control signals or devices upon city streets forming part of state highways – Approval by department of transportation

[RCW 46.61.340](#), Approaching train signal

[RCW 47.24.020\(6\)](#) and [\(13\)](#), Jurisdiction, control

[RCW 47.36.020](#), Traffic control signals

[RCW 47.36.025](#), Vehicle-activated traffic control signals – Detection of motorcycles and bicycles

[RCW 47.36.060](#), Traffic devices on county roads and city streets

[Washington Administrative Code \(WAC\) 468 18-040](#), Design standards for rearranged county roads, frontage roads, access roads, intersections, ramps and crossings

[WAC 468-18-050](#), Policy on the construction, improvement and maintenance of intersections of state highways and city streets

“City Streets as Part of State Highways: Guidelines Reached by the Washington State Department of Transportation and the Association of Washington Cities on the Interpretation of

Selected Topics of [RCW 47.24](#) and Figures of [WAC 468-18-050](#) for the Construction, Operations and Maintenance Responsibilities of WSDOT and Cities for Such Streets,” April 30, 1997.

[WAC 468-95](#), Manual on Uniform Traffic Control Devices for Streets and Highways (Washington State Supplement)

### **1330.08(2) Design Guidance**

*A Policy on the Geometric Design of Highways and City Streets* (Green Book), AASHTO

*Guide for Determining Time Requirements for Traffic Signal Preemption at Highway-Rail Grade Crossings* (TxDOT Form 2304) and *Instructions for Form 2304* (TxDOT Form 2304-I), Texas Department of Transportation

<http://www.txdot.gov/inside-txdot/forms-publications/forms/rail.html>

*Manual on Uniform Traffic Control Devices for Streets and Highways*, USDOT, FHWA; as adopted and modified by [Chapter 468-95 WAC](#) “Manual on uniform traffic control devices for streets and highways” (MUTCD)

*Plans Preparation Manual*, M 22-31, WSDOT

*Revised Draft Guidelines for Accessible Public Rights-of-Way*, (PROWAG), November 23, 2005, United States Access Board

*Standard Plans for Road, Bridge, and Municipal Construction* (Standard Plans), M 21 01, WSDOT

*Standard Specifications for Road, Bridge, and Municipal Construction* (Standard Specifications), M 41-10, WSDOT

WSDOT Traffic Design Resources

[www.wsdot.wa.gov/design/traffic/](http://www.wsdot.wa.gov/design/traffic/)



- [1360.01 General](#)
- [1360.02 Interchange Design](#)
- [1360.03 Ramps](#)
- [1360.04 Interchange Connections](#)
- [1360.05 Ramp Terminal Intersections at Crossroads](#)
- [1360.06 Interchanges on Two-Lane Highways](#)
- [1360.07 Interchange Plans for Approval](#)
- [1360.08 Documentation](#)
- [1360.09 References](#)

## 1360.01 General

The primary purpose of an interchange is to reduce conflicts caused by vehicle crossings and minimize conflicting left-turn movements. Provide interchanges on all Interstate highways and freeways, and at other locations where traffic cannot be controlled efficiently by intersections at grade.

For additional information, see the following chapters:

Chapter	Subject
520	Access control
530	Limited access
550	<u><a href="#">Access Revision Report</a></u>
1103	Design controls
1106	Design element dimensions
1240	Turning widths
1250	Cross Slope and Superelevation
1310	Intersections
1410	HOV lanes
1420	HOV direct access connections

## 1360.02 Interchange Design

### 1360.02(1) General

All freeway exits and entrances, except HOV direct access connections, are to connect on the right of through traffic. Variations from this will be considered only for special conditions.

HOV direct access connections may be constructed on the left of through traffic when they are designed in accordance with [Chapter 1420](#).

Provide complete ramp facilities for all directions of travel wherever possible. However, give primary consideration to the basic traffic movement function that the interchange is to fulfill.

Complications are rarely encountered in the design and location of rural interchanges that simply provide a means of exchanging traffic between a limited access freeway and a local

crossroad. Carefully consider the economic and operational effects of locating traffic interchanges along a freeway through a community, particularly with respect to local access, to provide convenient local service without reducing the capacity of the major route(s).

Where freeway-to-freeway interchanges are involved, do not provide ramps for local access unless they can be added conveniently and without detriment to efficient traffic flow or reduction of capacity, either ramp or freeway main line. When exchange of traffic between freeways is the basic function, and local access is prohibited by access control restrictions or traffic volume, separate interchanges for local service may be needed.

### **1360.02(2) Interchange Patterns**

Basic interchange patterns have been established that can be used under certain general conditions and modified or combined to apply to many more. Consider alternatives in the design of a specific facility; however, the conditions in the area and on the highway involved govern the final design of the interchange.

Selection of the final design is based on a study of projected traffic volumes, site conditions, geometric controls, criteria for intersecting legs and turning roadways, driver expectancy, consistent ramp patterns, continuity, and cost.

The patterns most frequently used for interchange design are those commonly described as directional, semi directional, cloverleaf, partial cloverleaf, diamond, and single point (urban) interchange (see [Exhibit 1360-1](#)).

#### **1360.02(2)(a) Directional**

A directional interchange is the most effective design for connection of intersecting freeways. The directional pattern has the advantage of reduced travel distance, increased speed of operation, and higher capacity. These designs eliminate weaving and have a further advantage over cloverleaf designs in avoiding the loss of sense of direction drivers experience in traveling a loop. This type of interchange is costly to construct, commonly using a four-level structure.

#### **1360.02(2)(b) Semi directional**

A semi directional interchange has ramps that loop around the intersection of the highways. This results in multiple single-level structures and more area than the directional interchange.

#### **1360.02(2)(c) Cloverleaf**

The full cloverleaf interchange has four loop ramps for the left-turning traffic. Outer ramps provide for the right turns. A full cloverleaf is the minimum type interchange for a freeway-to-freeway interchange. Cloverleaf designs often incorporate a C-D road to minimize signing difficulties and remove weaving conflicts from the main roadway.

The principal advantage of this design is the elimination of all left-turn conflicts with one single-level structure. Because all movements are merging movements, it is adaptable to any grade line arrangement.

The cloverleaf has some major disadvantages. The left-turn movement has a circuitous route on the loop ramp, the speeds are low on the loop ramp, and there are weaving conflicts between the loop ramps. The cloverleaf also needs a large area. The weaving and the radius of the loop ramps are a capacity constraint on the left-turn movements.

- 1410.01 [General](#)
- 1410.02 [Preliminary Design and Planning](#)
- 1410.03 [Operations](#)
- 1410.04 [Design Criteria](#)
- 1410.05 [Documentation](#)
- 1410.06 [References](#)

## 1410.01 General

High-occupancy vehicle (HOV) facilities include separate HOV roadways, HOV lanes, transit lanes, HOV direct access ramps, and flyer stops. The objectives for the HOV facilities are:

- Improve the capability of corridors to move more people by increasing the number of people per vehicle.
- Provide travel time savings and a more reliable trip time to HOV lane users.
- Provide travel options for HOVs without adversely affecting the general-purpose lanes.

Plan, design, and construct HOV facilities that provide intermodal linkages. Give consideration to future highway system capacity needs. Whenever possible, design HOV lanes so that the level of service for the general-purpose lanes is not degraded.

In urban corridors that do not currently have planned or existing HOV lanes, complete an analysis of the need for HOV lanes before proceeding with any projects for additional general-purpose lanes. In corridors where both HOV and general-purpose facilities are planned, construct the HOV lane before or simultaneously with the construction of new general-purpose lanes.

For additional information, see the following chapters:

Chapter	Subject
<a href="#">1230</a>	Geometric cross section
<a href="#">1240</a>	General-purpose turning roadway widths
<a href="#">1420</a>	HOV direct access

## 1410.02 Preliminary Design and Planning

### 1410.02(1) *Planning Elements for Design*

In order to determine the appropriate design options for an HOV facility, establish the travel demand and capacity, identify suitable corridors, evaluate the HOV facility location and length, and estimate the HOV demand. A viable HOV facility satisfies the following criteria:

- It is part of an overall transportation plan.
- It has the support of the community and public.
- It responds to demonstrated congestion or near-term anticipated congestion: Level of Service E or F for at least one hour of peak period (traffic approaching a capacity of 1,700 to 2,000 vehicles per hour per lane) or average speeds less than 30 mph during peak periods over an extended distance.

- Except for a bypass of a local bottleneck, it is of sufficient length to provide a travel time saving of at least five minutes during the peak periods.
- It has sufficient numbers of HOV users for a cost-effective facility and avoids the perception of under-utilization (HOV volumes of 400 to 500 vehicles per hour on nonseparated lanes and 600 to 800 on separated facilities).
- It provides a safe, efficient, and enforceable operation.

A queue or bottleneck bypass can be effective without satisfying all of the above. An isolated bypass can be viable when there is localized, recurring traffic congestion, and such treatment can provide a travel time saving to a sufficient number of HOV users.

The efficiency of the HOV facility can be affected by the access provisions. Direct access between park & ride/transit facilities and an HOV lane is the most desirable, but it is also an expensive alternative. Direct access options are discussed in [Chapter 1420](#).

Document the need for the HOV lane and how the proposed lane will meet those needs.

### **1410.02(2) HOV Facility Type**

Make a determination as to the type of HOV lane. The three major choices are: separated roadway, buffer-separated lane, and nonseparated HOV lane.

#### **1410.02(2)(a) Separated Roadway**

The separated roadway can be either a one-way reversible or a two-way operation. The directional split in the peak periods, available space, and operating logistics are factors to be considered. A separated HOV roadway may be located in the median of the freeway, next to the freeway, or on an independent alignment. Separated HOV facilities are more effective for:

- Large HOV volumes.
- Large merging and weaving volumes.
- Long-distance HOV travel.

Reversible separated roadways operate effectively where there are major directional splits during peak periods. Consider potential changes in this traffic pattern and design the facility to accommodate possible conversion to a two-way operation. The separated roadway is normally more efficient, provides for the higher level of safety, and is more easily enforced. However, it is generally the most expensive type of HOV facility.

#### **1410.02(2)(b) Buffer-Separated Lane**

A buffer-separated HOV lane is similar to a freeway nonseparated HOV lane on the left, but with a buffer between the HOV lane and the general-purpose lanes. The addition of a buffer provides better delineation between the lanes and controls access between the HOV lane and general-purpose lanes to improve operations.

#### **1410.02(2)(c) Nonseparated Lane**

Nonseparated HOV lanes operate in the same direction and immediately adjacent to the general-purpose lanes. They are located either to the left (desirable) or to the right of the general-purpose lanes. Nonseparated HOV lanes are normally less expensive and easier to implement, and they provide more opportunity for frequent access. However, the ease of access can create more problems for enforcement and a greater potential for conflicts.



### 1410.02(3) Freeway Operational Alternatives

For an HOV lane on a limited access facility, consider the following operational alternatives:

- Inside (desirable) or outside HOV lane
- Lane conversion
- Use of existing shoulder—not recommended for permanent operations
- HOV direct access ramps
- Queue bypasses
- Flyer stops
- Hours of operation

When evaluating alternatives, consider a combination of alternatives to provide the optimum solution for the corridor. Also, incorporate flexibility into the design in order not to preclude potential changes in operation, such as changing an outside lane to an inside lane or a reversible facility to two-way operations. Access, freeway-to-freeway connections, and enforcement will have to be accommodated for such changes. Document the operational alternatives.

#### 1410.02(3)(a) Inside vs. Outside HOV Lane

System continuity and consistency of HOV lane placement along a corridor are important, and they influence facility development decisions. Other issues include land use, trip patterns, transit vehicle service, HOV volume, ramp volume, congestion levels, enforcement, and direct access to facilities.

The inside (left) HOV lane is most appropriate for a corridor with long-distance trip patterns, such as a freeway providing mobility to and from a large activity center. These trips are characterized by long-distance commuters and express transit service. Maximum capacity for an effective inside HOV lane is approximately 1,500 vehicles per hour. When HOVs weaving across the general-purpose lanes cause severe congestion, consider providing HOV direct access ramps, separated HOV roadways, or a higher-occupancy designation. Inside lanes are preferred for HOV lanes on freeways.

The outside (right) HOV lane is most appropriate for a corridor with shorter, more widely dispersed trip patterns. These trip patterns are characterized by transit vehicle routes that exit and enter at nearly every interchange. The maximum capacity for an effective outside HOV lane is reduced and potential conflicts are increased by heavy main line congestion and large entering and exiting general-purpose volumes.

#### 1410.02(3)(b) Conversion of a General-Purpose Lane

The use of an existing general-purpose lane for an HOV lane is an undesirable option; however, conversion of a lane to an HOV lane might be justified when the conversion provides greater people-moving capability on the roadway. Use of an existing freeway lane as an HOV lane will be considered only with a Design Analysis.

Given sufficient existing capacity, converting a general-purpose lane to an HOV lane can provide for greater people moving capability in the future without significantly affecting the existing roadway operations. The fastest and least expensive method for providing an HOV lane is through conversion of a general-purpose lane. Restriping and signing are sometimes all that is needed. Converting a general-purpose lane to HOV use will likely have environmental benefits.

This method, however, is controversial from a public acceptance standpoint. Public support might be gained through an effective public involvement program (see [Chapter 210](#)).

Do not convert a general-purpose lane to an HOV lane unless it enhances the corridor's people-moving capacity. Conduct an analysis that includes:

- Public acceptance of the lane conversion.
- Current and long-term traffic impacts on the adjacent general-purpose lanes and the HOV lane.
- Impacts to the neighboring streets and arterials.
- Legal, environmental, and safety impacts.

#### **1410.02(3)(c) Use of Existing Shoulder**

When considering the alternatives in order to provide additional width for an HOV lane, the use of the existing shoulder is an undesirable option. Use of the shoulder on a freeway or freeway ramp as an HOV lane will be considered only with a Design Analysis.

Consider shoulder conversion to an HOV lane when traffic volumes are heavy and the conversion is a temporary measure. Another alternative is to use the shoulder as a permanent measure to serve as a transit-only or queue bypass lane during peak hours and then revert to a shoulder in off-peak hours.

The use of the shoulder creates special signing, operational, and enforcement issues. An agreement is required with the transit agency to limit transit vehicle use of the shoulder to peak hours. Provide signing that clearly defines the use of the shoulder. Institute special operations to clear the shoulder for the designated hours.

The existing shoulder pavement is often not designed to carry heavy volumes of vehicles, especially transit vehicles. As a result, repaving and reconstruction of the shoulder might be required.

#### **1410.02(3)(d) HOV Direct Access Ramps**

To improve the efficiency of an HOV system, exclusive HOV access connections for an inside HOV lane may be considered. (See [Chapter 1420](#) for information on HOV direct access connections.) Direct access reduces the need for HOVs to cross the general-purpose lanes from right-side ramps. Transit vehicles will be able to use the HOV lane and provide service to park & ride lots, flyer stops, or other transit stops by the HOV direct access ramps.

#### **1410.02(3)(e) Queue Bypass Lanes**

A queue bypass lane allows HOVs to save time by avoiding congestion at an isolated bottleneck. Consider a queue bypass if the time savings for bypassing HOVs is one minute or more. Typical locations for queue bypasses are at ramp meters, signalized intersections, toll plazas or ferry approaches, and locations with isolated main line congestion. Queue bypass lanes can be built along with a corridor HOV facility or independently. In most cases, they are relatively low cost and easily implemented.

Where an HOV bypass is being considered at a ramp metering site, consult the Region Traffic Engineer prior to implementation. When an HOV bypass is constructed at a ramp metering site, the ramp meter system should be designed to allow for metering the HOV bypass lane as well. At a minimum, an overhead signal support (Type II) with a tenon position for a signal display for

the HOV bypass lane, and sufficient space in the conduit system for additional wiring, should be provided.

#### **1410.02(3)(f) Flyer Stops**

Flyer stops reduce the time required for express transit vehicles to serve intermediate destinations. However, passengers must travel greater distances to reach the loading platform. (See [Chapter 1420](#) for information on flyer stops.)

#### **1410.02(3)(g) Hours of Operation**

An HOV designation on freeway HOV lanes 24 hours a day provides benefits to users during off-peak periods, minimizes potential confusion, makes enforcement easier, and simplifies signing and striping. However, 24-hour operation also might result in a lane not used during off-peak periods, negative public opinion, and the need for full-time enforcement.

### **1410.02(4) Arterial Street Operational Alternatives**

Arterial street HOV lanes also have a variety of HOV alternatives to be considered. Some of these alternatives are site-specific or have limited applications. Arterial HOV lanes differ from freeway HOV lanes in slower speeds, little access control (turning traffic can result in right-angle conflicts), and traffic signals. Arterial HOV lanes are occasionally designated for transit vehicles only, especially in cities with a large concentration of transit vehicles. When evaluating alternatives, consider traffic signal queues and managed access highway class. The alternatives include the following:

- Type of lane
- Left-side or right-side HOV lane
- Hours of operation
- Spot treatments
- Bus stops

When evaluating alternatives, consider a combination of alternatives to provide the optimum solution for the corridor. Also, incorporate flexibility into the design in order not to preclude potential changes in operation. Document the operational alternatives.

#### **1410.02(4)(a) Type of Lane**

Lanes can be transit-only or include all HOVs. Transit-only lanes are desirable where bus volumes are high with a high level of congestion. They increase the speed of transit vehicles through congested areas and improve the reliability of the transit service. Lanes that allow use by all HOVs are appropriate on corridors with high volumes of carpools and vanpools. They can collect carpools and vanpools in business and industrial areas and connect them to the freeway system.

#### **1410.02(4)(b) Left-Side or Right-Side HOV Lane**

Continuity of HOV lane location along a corridor is an important consideration when making the decision whether to locate an arterial street HOV lane on the left or right side of the street. Other issues include land use, trip patterns, transit vehicle service, safety, enforcement, and presence of parking.

The right side is desirable for arterial street HOV lanes on transit routes with frequent stops. It is the most convenient for passenger boarding at transit stops. It is also the most common location for HOV lanes on arterial streets. General-purpose traffic must cross the HOV lane to make a right turn at intersections and to access driveways. These turns across the HOV lane can create conflicts. Minimizing access points that create these conflict locations is recommended. Other issues to consider are on-street parking, stopping areas for delivery vehicles, and enforcement areas.

Left-side arterial street HOV lanes are less common than right-side lanes. HOV lanes on the left eliminate the potential conflicts with driveway access, on-street parking, and stopping areas for delivery vehicles. The result is fewer delays and higher speeds, making left-side arterial street HOV lanes appropriate for longer-distance trips. The disadvantages include the difficulty providing transit stops and the need to provide for left-turning general-purpose traffic.

#### **1410.02(4)(c) Hours of Operation**

An arterial street HOV lane can either operate as an HOV lane 24 hours a day or during peak hours only. Factors to consider in determining which to use include type of HOV lane, level of congestion, continuity, and enforcement.

HOV lanes operating 24 hours a day are desirable when congestion and HOV demand exists for extended periods throughout the day. The 24-hour operation provides benefits to users during off-peak periods, minimizes potential confusion, makes enforcement easier, and simplifies signing and striping. The disadvantages include negative public opinion if the lane is not used during off-peak periods, the need for full-time enforcement, and the loss of on-street parking.

Peak period HOV lanes are appropriate for arterial streets with HOV demand or congestion existing mainly during the peak period. Peak period HOV lanes provide HOV priority at the critical times of the day, lessen negative public perception of the HOV lane, and allow on-street parking or other shoulder uses at other times. The disadvantages include possible confusion to drivers, more difficult enforcement, increased signing, and the need to institute special operations to clear the shoulder or lane for the designated period.

#### **1410.02(4)(d) Spot Treatments**

An HOV spot treatment is used to give HOVs priority around a bottleneck. It can provide time savings, travel time reliability, and improved access to other facilities. Examples include a short HOV lane to provide access to a freeway on-ramp, one lane of a dual turn lane, a priority lane at ferry terminals, and priority at traffic signals.

Signal priority treatments that alter the sequence or duration of a traffic signal are techniques for providing preferential treatment for transit vehicles. The priority treatments can range from timing and phasing adjustments to signal preemption. Consider the overall impact on traffic. Preemption would normally not be an appropriate treatment where traffic signal timing and coordination are being utilized or where there are high traffic volumes on the cross streets.

#### **1410.02(4)(e) Bus Stops**

Normally, with arterial HOV lanes, there is not a shoulder suitable for a bus to use while stopped to load and unload passengers without blocking the lane. Therefore, bus stops are either in-lane or in a pullout. In-lane bus stops are the simplest type of bus stop. However, stopped buses will block the HOV lane; therefore, in-lane bus stops are only allowed in transit lanes. Bus pullouts

provide an area for buses to stop without blocking the HOV lane. Disadvantages include higher cost, reduced width for the sidewalk or other roadside area, and possible difficulty reentering the HOV lane. (See [Chapter 1430](#) for additional information on bus stop location and design.)

### **1410.03 Operations**

#### **1410.03(1) Vehicle Occupancy Designation**

Select the vehicle occupancy designation to provide the maximum movement of people in a corridor, provide free-flow HOV operations, reduce the empty lane perception, provide for the ability to accommodate future HOV growth within a corridor, and be consistent with the regional transportation plan and the policies adopted by the Metropolitan Planning Organization (MPO).

Establish an initial occupancy designation. It is WSDOT policy to use the 2+ designation as the initial occupancy designation. Consider a 3+ occupancy designation if it is anticipated during initial operation that the volumes will be 1,500 vehicles per hour for a left-side HOV lane, or 1,200 vehicles per hour for a right-side HOV lane, or that a 45 mph operating speed cannot be maintained for more than 90% of the peak hour.

#### **1410.03(2) Enforcement**

Enforcement is necessary for the success of an HOV facility. Coordination with the Washington State Patrol (WSP) is critical when the operational characteristics and design alternatives are being established. This involvement ensures the project is enforceable and will receive their support.

Provide both enforcement areas and observation points for high-speed HOV lanes and ramp facilities.

Barrier-separated facilities, because of the limited access, are the easiest facilities to enforce. Shoulders provided to accommodate breakdowns may also be used for enforcement. Reversible facilities have ramps for the reverse direction that may be used for enforcement. Gaps in the barrier may be needed so emergency vehicles can access barrier-separated HOV lanes.

Buffer-separated and nonseparated HOV lanes allow violators to easily enter and exit the HOV lane. Provide strategically located enforcement areas and observation points.

Consider the impact on safety and visibility for the overall facility during the planning and design of enforcement areas and observation points. Where HOV facilities do not have enforcement areas, or where officers perceive that the enforcement areas are inadequate, enforcement on the facility will be difficult and less effective.

#### **1410.03(3) Intelligent Transportation Systems**

The objective of Intelligent Transportation Systems (ITS) is to make more efficient use of our transportation network. This is done by collecting data, managing traffic, and relaying information to the motoring public.

It is important that an ITS system be incorporated into the HOV project and that the HOV facility fully utilize the ITS features available. This includes providing a strategy of incident management

since vehicle breakdowns and crashes have a significant impact on the efficient operation of the HOV facilities. (For more information on ITS, see [Chapter 1050](#).)

## **1410.04 Design Criteria**

### **1410.04(1) Design Procedures**

### **1410.04(2) Design Considerations**

HOV lanes are designed to the same criteria as the facilities to which they are attached. Design nonseparated and buffer-separated HOV lanes to match the vertical alignment, horizontal alignment, and cross slope of the adjacent lane.

### **1410.04(3) Adding an HOV Lane**

The options for adding an HOV lane are: reconstruction, restriping, combined reconstruction and restriping, and possibly lane conversion.

#### **1410.04(3)(a) Reconstruction**

Reconstruction involves creating roadway width. Additional right of way may be required.

#### **1410.04(3)(b) Restriping**

Restriping involves reallocating the existing paved roadway to create enough space to provide an additional HOV lane.

#### **1410.04(3)(c) Combined Reconstruction and Restriping**

Reconstruction and restriping can be combined to maximize use of the available right of way. For example, a new lane can be created through a combination of median reconstruction, shoulder reconstruction, and lane restriping. Handle each project on a case-by-case basis. Generally, consider the following reductions in order of preference:

- Reduction of the inside shoulder width, provided the enforcement and safety mitigation issues are addressed. (Give consideration to not precluding future HOV direct access ramps by over-reduction of the available median width.)
- Reduction of the interior general-purpose lane width to 11 feet.
- Reduction of the outside general-purpose lane width to 11 feet.
- Reduction of the HOV lane to 11 feet.
- Reduction of the outside shoulder width to 8 feet.

#### **1410.04(3)(d) Lane Conversion**

If lane width adjustments are made, thoroughly eradicate the old lane markings. It is desirable that longitudinal joints (new or existing) not conflict with tire track lines. If they do, consider overlaying the roadway before restriping.

## 1410.04(4) Design Criteria for Types of HOV Facilities

### 1410.04(4)(a) Separated Roadway HOV Facilities

The separated HOV facility can be single-lane or multilane and directional or reversible (see [Exhibit 1410-2](#)).

#### 1. Lane Widths

For traveled way width (WR) on turning roadways, see [Exhibit 1410-1](#).

#### 2. Shoulder Widths

The shoulder width requirements are as follows:

- The minimum width for the sum of the two shoulders is 12 feet for one-lane facilities and 14 feet for two-lane facilities.
- Provide a width of at least 10 feet for one of the shoulders for disabled vehicles. The minimum for the other shoulder is 2 feet for one-lane facilities and 4 feet for two-lane facilities.
- The wider shoulder may be on the left or the right. Maintain the wide shoulder on the same side throughout the facility.

#### 3. Total Widths

To reduce the probability of blocking the HOV facility, make the total width (lane width plus paved shoulders) wide enough to allow an A BUS to pass a stalled A BUS. For single-lane facilities, the traveled way widths (WR), given in [Exhibit 1410-1](#), plus the 12-foot total shoulder width will provide for this passing for radii (R) 100 feet or greater. For R of 75 feet, a total roadway width of 33 feet is needed, and for R of 50 feet, a total roadway width of 41 feet is needed to provide for the passing.

**Exhibit 1410-1 Minimum Traveled Way Widths for Articulated Buses**

R (ft) <sup>[1]</sup>	WR (ft)	
	1-Lane	2-Lane
3,001 to Tangent	13 <sup>[2]</sup>	24
3,000	14	24
2,000	14	25
1,000	15	26
500	15	27
300	15	28
200	16	29
150	17	31
100	18	34
75	19	37
50	22	45
<b>Notes:</b>		
[1] Radius (R) is on the outside edge of traveled way on 1-lane and centerline on 2-lane roadways.		
[2] May be reduced to 12 ft on tangent.		

#### 1410.04(4)(b) Nonseparated Freeway HOV Lanes

For both inside and outside HOV lanes, the minimum lane width is 12 feet and the minimum shoulder width is 10 feet (see [Exhibit 1410-2](#)).

When a left shoulder less than 10 feet wide is proposed for distances exceeding 1.5 miles, provide enforcement and observation areas at 1- to 2 mile intervals (see [1410.04\(7\)](#)).

Where left shoulders less than 8 feet wide are proposed for lengths of roadway exceeding 0.5 mile, provide safety refuge areas at 0.5- to 1-mile intervals. These can be in addition to or in conjunction with the enforcement areas.

Allow general-purpose traffic to cross HOV lanes at on- and off-ramps.

#### 1410.04(4)(c) Buffer-Separated HOV Lanes

Design buffer-separated HOV lanes the same as for inside nonseparated HOV lanes, except for a buffer 2 to 4 feet in width or 10 feet or greater in width with pavement marking, with supplemental signing, to restrict crossing. For buffer-separated HOV lanes with a buffer at least 4 feet wide, the left shoulder may be reduced to 8 feet. Buffer widths between 4 and 10 feet are undesirable because they may appear to be wide enough for a refuge area, but they are too narrow. Provide gaps in the buffer to allow access to the HOV lane.

#### 1410.04(4)(d) Arterial Street HOV Lanes

The minimum width for an arterial street HOV lane is 12 feet. Allow general-purpose traffic to cross the HOV lanes to turn at intersections and to access driveways (see [Exhibit 1410-2](#)).

For right-side HOV lanes adjacent to curbs, provide a 4-foot shoulder between the HOV lane and the face of curb. The shoulder may be reduced to 2 feet with justification.

For HOV lanes on the left, a 1-foot left shoulder between the HOV lane and the face of curb is required. When concrete barrier is adjacent to the HOV lane, the minimum shoulder is 2 feet.

#### 1410.04(4)(e) HOV Ramp Meter Bypass

An HOV bypass may be created by widening an existing ramp, constructing a new ramp where right of way is available, or reallocating the existing pavement width (provided the shoulders are full depth). For ramps with a single general purpose lane and an HOV bypass, consider installing an overhead signal support to allow for the installation of an overhead sign (7.5 square feet maximum) and a ramp meter display for the HOV bypass. For ramps with two general-purpose lanes and an HOV bypass, provide an overhead signal support capable of supporting the installation of a sign (7.5 square feet maximum) and a ramp meter display for the HOV bypass.

Ramp meter bypass lanes may be located on the left or right of metered lanes. Typically, bypass lanes are located on the left side of the ramp. Consult with local transit agencies and the region Traffic Office for guidance on which side to place the HOV bypass.

Consider the existing conditions at each location when designing a ramp meter bypass. Design a single-lane ramp with a single metered lane and an HOV bypass as shown in [Exhibit 1410-4a](#). Make the total width of the metered and bypass lanes equal to a 2-lane ramp (see [Chapters 1240](#) and [1360](#)). Design a ramp with two metered lanes and an HOV bypass as shown in [Exhibit 1410-4b](#). Make the width of the two metered lanes equal to a 2-lane ramp (see [Chapters 1240](#) and [1360](#)) and the width of the bypass lane as shown in [Exhibit 1410-3](#). The design shown in



[Exhibit 1410-4b](#) requires that the ramp operate as a single-lane ramp when the meter is not in operation. Both [Exhibits 1410-4a](#) and [4b](#) show an observation point/enforcement area. Document any other enforcement area designs in the design documentation package. An alternative is to provide a 10 foot outside shoulder from the stop bar to the main line.

#### **1410.04(5) HOV Direct Access Ramps**

HOV direct access ramps provide access between an HOV lane and another freeway, a local arterial street, a flyer stop, or a park & ride facility. Design HOV direct access ramps in accordance with [Chapter 1420](#).

#### **1410.04(6) HOV Lane Termination**

Locate the beginning and end of an HOV lane at logical points. Provide decision sight distance, signing, and pavement markings at the termination points.

The desirable method of terminating an inside HOV lane is to provide a straight through move for the HOV traffic, ending the HOV restriction and dropping a general-purpose lane on the right. However, analyze volumes for both the HOV lanes and general-purpose lanes, as well as the geometric conditions, to optimize the overall operational performance of the facility.

#### **1410.04(7) Enforcement Areas**

Enforcement of the inside HOV lane can be done with a minimum 10-foot inside shoulder. For continuous lengths of barrier exceeding 2 miles, a 12-foot shoulder is recommended for the whole length of the barrier.

For inside shoulders less than 10 feet, locate enforcement and observation areas at 1 to 2-mile intervals or based on the recommendations of the WSP. These areas can also serve as refuge areas for disabled vehicles (see [Exhibits 1410-5a](#) and [5b](#)).

Provide observation points approximately 1,300 feet before enforcement areas. They can be designed to serve both patrol cars and motorcycles or motorcycles only. Coordinate with the WSP during the design stage to provide effective placement and utilization of the observation points. Median openings give motorcycle officers the added advantage of being able to quickly respond to emergencies in the opposing lanes (see [Exhibit 1410-5b](#)). The ideal observation point places the motorcycle officer 3 feet above the HOV lane and outside the shoulder so the officer can look down into a vehicle.

Locate the enforcement area on the right side for queue bypasses and downstream from the stop bar so the officer can be an effective deterrent (see [Exhibits 1410-4a](#) and [4b](#)).

An optional signal status indicator for enforcement may be placed at HOV lane installations that are metered. The indicator faces the enforcement area so that a WSP officer can determine whether vehicles are violating the ramp meter. The indicator allows the WSP officer to simultaneously enforce two areas: the ramp meter and the HOV lane. Consult with the WSP regarding use at all locations.

For additional information on enforcement signal heads, see the Traffic Manual regarding HOV metered bypasses.

## 1410.04(8) Signs and Pavement Markings

### 1410.04(8)(a) Signs

Provide post-mounted HOV preferential lane signs next to the HOV lane or overhead-mounted signs over the HOV lane. Make the sign wording clear and precise, stating which lane is restricted, the type of HOVs allowed, and the HOV vehicle occupancy designation for that section of road. The sign size, location, and spacing are dependent upon the conditions under which the sign is used. Roadside signs can also be used to convey other HOV information such as the HERO program, carpool information, telephone numbers, and violation fines. Some situations may call for the use of variable message signs.

Place overhead signs directly over the HOV lane to provide maximum visibility. Use a sequence of overhead signs at the beginning and end of freeway HOV facilities. Overhead signs can also be used in conjunction with roadside signs along the roadway.

### 1410.04(8)(b) Pavement Markings

Provide pavement markings that conform to the Traffic Manual and the Standard Plans.

### 1410.04(8)(c) Interchanges

In the vicinity of interchange on- and off-connections where merging or exiting traffic crosses an HOV lane, make provisions for general-purpose traffic using the HOV lane. These provisions include signing and striping that clearly show the changes in HOV versus general traffic restrictions. (See the Standard Plans for pavement markings and signing.)

## 1410.05 Documentation

Refer to [Chapter 300](#) for design documentation requirements.

## 1410.06 References

### 1410.06(1) *Federal/State Laws and Codes*

[Revised Code of Washington \(RCW\) 46.61.165](#), High-occupancy vehicle lanes

[RCW 47.52.025](#), Additional powers – Controlling use of limited access facilities

–High occupancy vehicle lanes

[Washington Administrative Code \(WAC\) 468-510-010](#), High occupancy vehicles (HOVs)

### 1410.06(2) *Design Guidance*

[Manual on Uniform Traffic Control Devices for Streets and Highways](#), USDOT, FHWA; as adopted and modified by Chapter 468-95 WAC “Manual on uniform traffic control devices for streets and highways” (MUTCD)

*Standard Plans for Road, Bridge, and Municipal Construction* ([Standard Plans](#)), M 21 01, WSDOT

[Traffic Manual](#), M 51-02, WSDOT

**1410.06(3) Supporting Information**

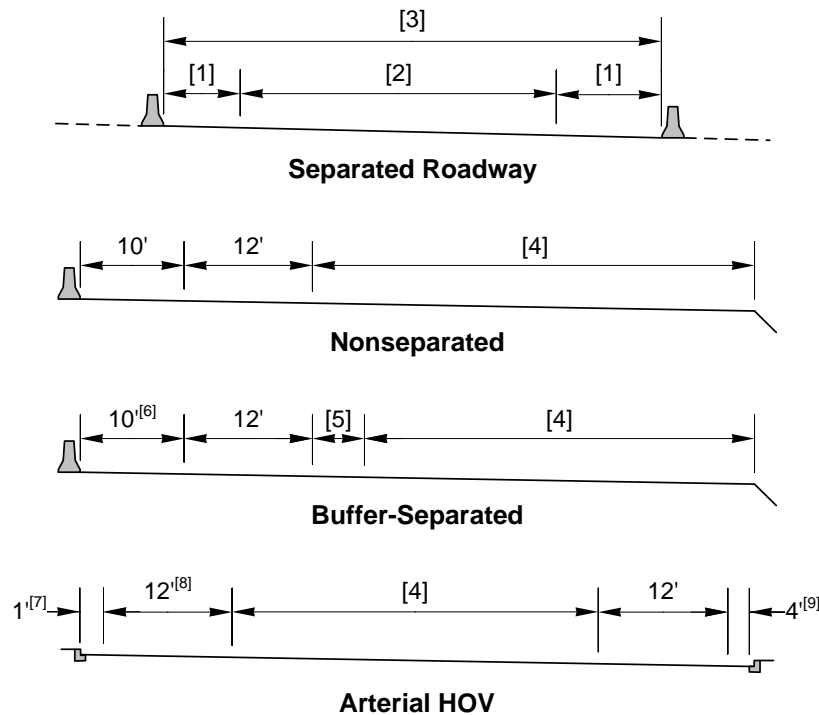
*Design Features of High-Occupancy Vehicle Lanes, Institute of Traffic Engineers (ITE)*

*Guide for the Design of High-Occupancy Vehicle Facilities, American Association of State Highway and Transportation Officials (AASHTO)*

*High-Occupancy Vehicle Facilities, Parsons Brinkerhoff, Inc., 1990*

*HOV Systems Manual, NCHRP Report 414, 1998*

## Exhibit 1410-2 Typical HOV Lane Sections



## Notes:

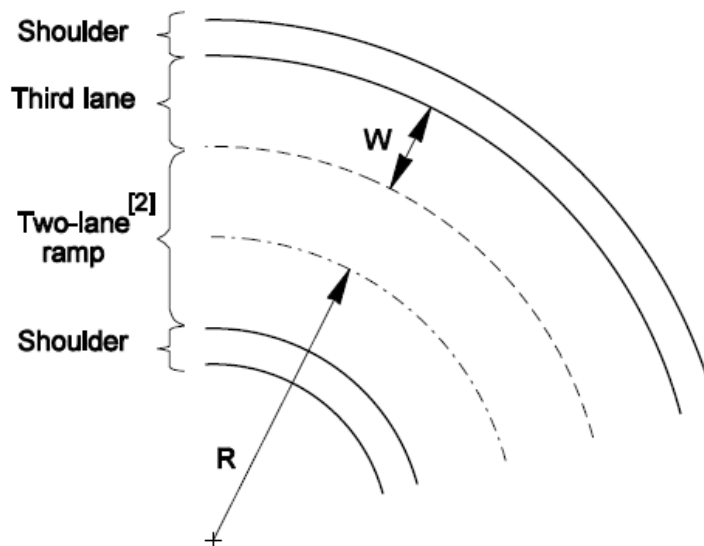
- [1] The sum of the two shoulders is 12 ft for one-lane and 14 ft for two-lane facilities. Provide one shoulder with a width of at least 10 ft for disabled vehicles. The wider shoulder may be on the left or the right. Maintain the wide shoulder on the same side throughout the facility (see [1410.04\(4\)\(a\)2](#)).
- [2] 12-ft minimum for single lane, 24-ft minimum for two lanes. Wider width is required on curves (see [1410.04\(4\)\(a\)1](#) and [Exhibit 1410-1](#)).
- [3] For total width requirements, see [1410.04\(4\)\(a\)3](#).
- [4] Width as required, and the number of lanes.
- [5] Buffer 2 to 4 ft or 10 ft or more.
- [6] When buffer width is 4 ft or more, may be reduced to 8 ft.
- [7] 2 ft when adjacent to concrete barrier.
- [8] Arterial HOV lanes on the left operate in the same direction as the adjacent general-purpose lane.
- [9] May be reduced to 2 ft with justification.

## Exhibit 1410-3 Roadway Widths for Two-Lane Ramps With an HOV Lane

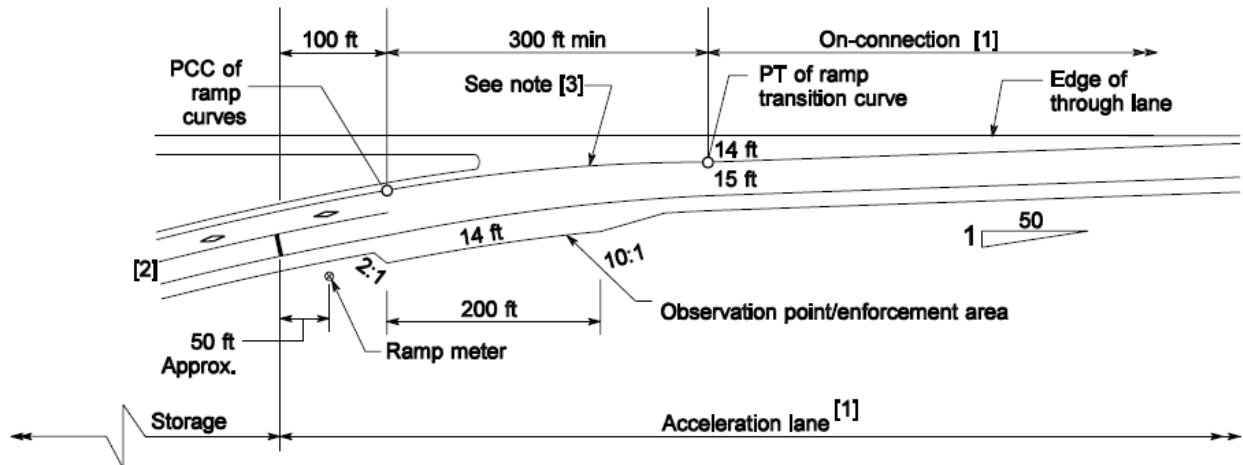
Radius of Two-Lane Ramp R (ft)	Design Width of Third Lane <sup>[1]</sup> W (ft)
1,000 to Tangent	12
999 to 500	13
499 to 250	14
249 to 200	15
199 to 150	16
149 to 100	17

## Notes:

- [1] Apply additional width to two-lane ramp widths.
- [2] For turning roadway widths, see traveled way width for two-lane one-way turning roadways in [Chapter 1240](#).



## Exhibit 1410-4a Single-Lane Ramp Meter With HOV Bypass



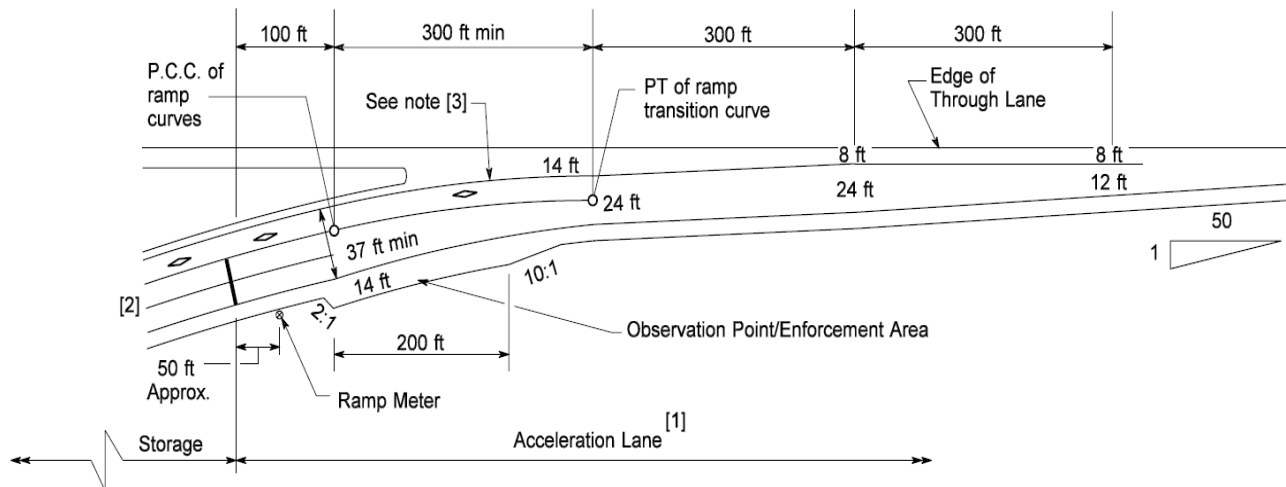
## Notes:

- [1] For on-connection details and for acceleration lane length, see [Chapter 1360](#).
- [2] For ramp lane and shoulder widths for a 2-lane ramp, see [Chapters 1240](#) and [1360](#).
- [3] A transition curve with a minimum radius of 3,000 ft is desirable. The minimum length is 300 ft. When the main line is on a curve to the left, the transition may vary from a 3,000 ft radius to tangent to the main line.

## General:

For striping details, see the [Standard Plans](#).

## Exhibit 1410-4b Two-Lane Ramp Meter With HOV Bypass



## Notes:

- [1] For acceleration lane length, see [Chapter 1360](#).
- [2] For 2-lane ramp lane and shoulder widths, see [Chapters 1240](#) and [1360](#). For 3rd lane width, see [Exhibit 1410-3](#).
- [3] A transition curve with a minimum radius of 3000 ft is desirable. The minimum length is 300 ft. When the main line is on a curve to the left, the transition may vary from a 3000 ft radius to tangent to the main line.

## General:

For striping details, see the [Standard Plans](#).

Exhibit 1410-5a Enforcement Area: One Direction Only

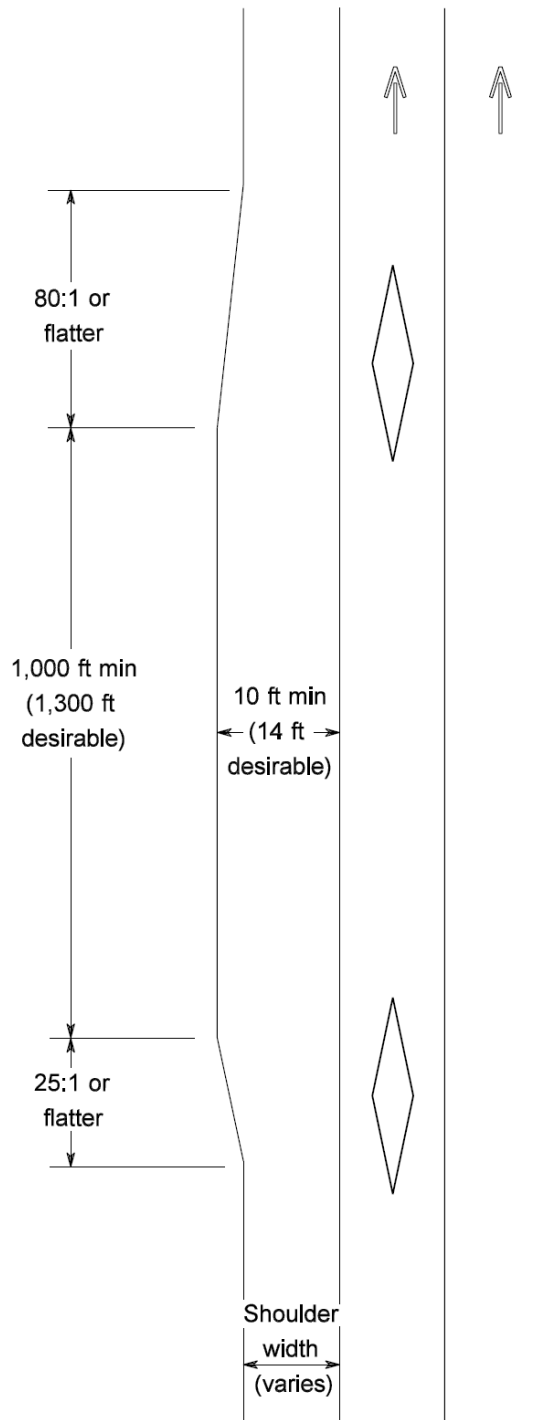
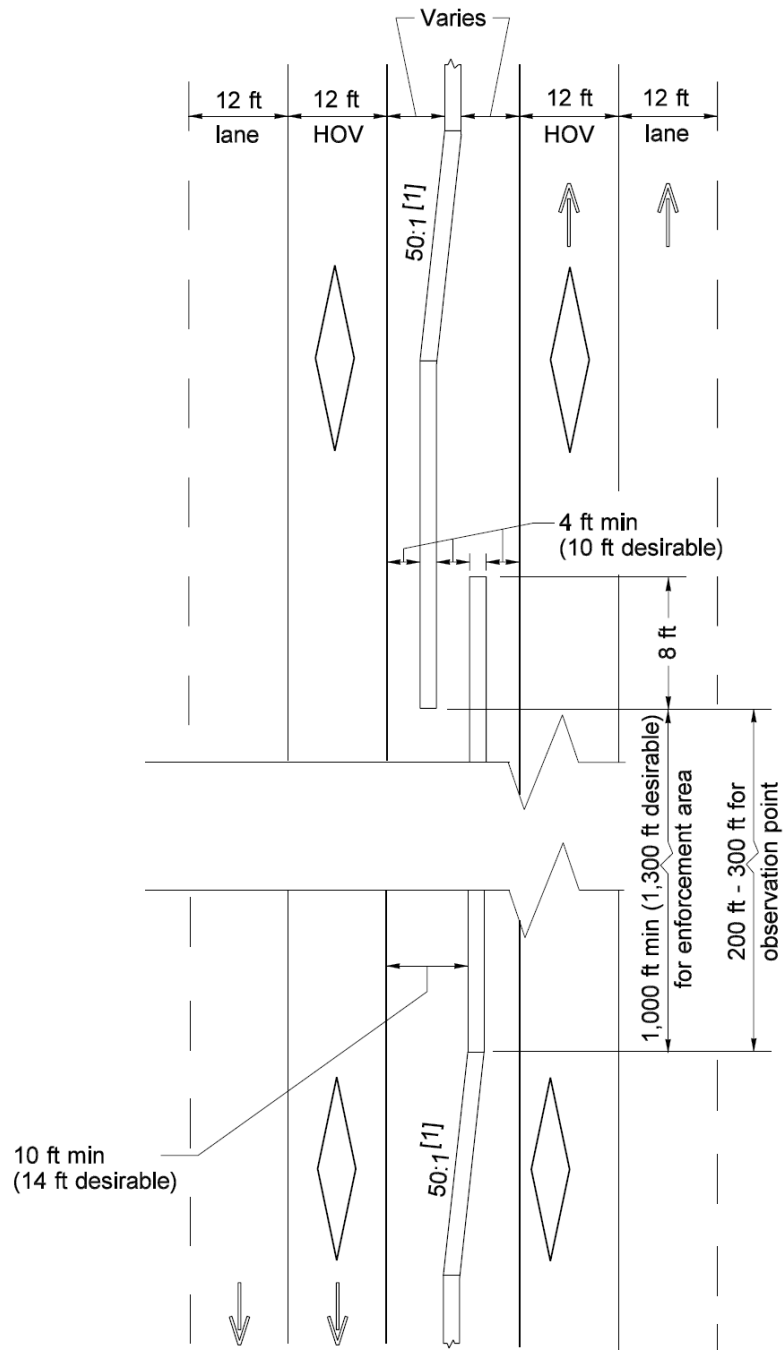




Exhibit 1410-5b Enforcement Area: Median



Note:

[1] For median width transition, see [Chapter 1210](#).



<a href="#">1420.01</a>	<a href="#">General</a>
<a href="#">1420.02</a>	<a href="#">HOV Access Types and Locations</a>
<a href="#">1420.03</a>	<a href="#">Direct Access Geometrics</a>
<a href="#">1420.04</a>	<a href="#">Passenger Access</a>
<a href="#">1420.05</a>	<a href="#">Traffic Design Elements</a>
<a href="#">1420.06</a>	<a href="#">Documentation</a>
<a href="#">1420.07</a>	<a href="#">References</a>

## 1420.01 General

This chapter provides Washington State Department of Transportation (WSDOT) design guidance for left-side direct access facilities for high-occupancy vehicles (HOVs) between freeway HOV lanes and flyer stops within the freeway right of way or facilities outside of the right of way. Design right-side HOV-only access facilities in accordance with [Chapter 1360](#).

Direct access eliminates the need for left-side HOV lane users to cross the general-purpose lanes to right-side general-purpose ramps. Also, transit vehicles can use the HOV lane and provide service to the HOV direct access facility.

Providing the HOV user access to the inside HOV lane without mixing with the general-purpose traffic saves the user additional travel time and aids in safety, enforcement, incident handling, and overall operation of the HOV facility.

Locations for direct access ramps include HOV facilities on intersecting routes, park & ride lots, flyer stops, and locations with a demonstrated demand. Coordinate with the local transit agencies to identify these key locations. Give priority to locations that serve the greatest number of transit vehicles and other HOVs.

### 1420.01(1) *Practical Design*

Under WSDOT practical design (see [Chapter 1100](#) and Division 11) an important function of alternative solution formulation is to identify alternatives that address the baseline need while balancing the performance trade-offs identified in the process. Since HOV direct access connections are often added to existing corridors, performance tradeoffs to mainline GP lanes or other elements may be needed and acceptable to provide the new HOV connections. Document performance tradeoffs according to [Chapter 1100](#) and Division 11.

### 1420.01(2) *Reviews, Studies, and Reports*

The [practical design](#) project development process is to be followed when developing an HOV direct access project (see [Chapter 1100](#)). Despite the nature of the projects that are the focus of this chapter, most facets of the project development process remain unchanged. For example, early coordination with others is a vital part of developing a project. There are also environmental considerations, public involvement, and value engineering studies (see [Chapter 310](#)). There may also be reviews, studies, and reports required by agreements with regional transit authorities or other agencies.

Provide an Access Revision Report (ARR) (see [Chapter 550](#)) when there is a proposal to add, delete, or change an access point. Provide the operational analysis from the report for all flyer stops. For left-side connections, include the commitment that the connection will be used solely by HOVs or will be closed.

Throughout the project development phase, make sure the project:

- Need Statement (see [Chapter 1101](#)) and cost estimate are correct.
- Development process is on schedule.
- Documents are biddable.
- Will be constructible.
- Will be maintainable.

Constructability of HOV direct access facilities is an important consideration during the design phase. These facilities will typically be constructed on existing highways with traffic maintained on-site. Key goals are to:

- Provide a project that can be built.
- Plan a construction strategy.
- Provide a safe work zone.
- Minimize construction delays.

Consider access to these facilities by maintenance crews. Avoid items that require a significant maintenance effort and might result in lane closure for routine maintenance or repair.

### **1420.01(3) Left-Side Connections**

Left-side connections are allowed only when they serve HOVs exclusively and connect to an HOV lane. The higher traffic volume associated with general-purpose traffic is not acceptable for left-side connections. If the demand for an HOV direct access decreases to the point that the HOV direct access connection is no longer desirable, the connection must be closed.

## **1420.02 HOV Access Types and Locations**

To provide direct access for high-occupancy vehicles from the HOV lane to a passenger loading facility, there are many options and many constraints. Following are some of the options (selected as being usable on Washington's freeways) and constraints regarding their use.

To select an option, first establish the need, choose possible locations, evaluate site features (such as terrain, existing structures, median widths), and evaluate existing HOV information (such as lanes, park & ride facilities, transit routes and schedules, and origin and destination studies). Choose a location that meets access point spacing requirements and will not degrade traffic operations on the main line.

Important constraints to transit stop designs are:

- Passenger access routes and waiting areas are separated from freeway traffic.
- Passenger access to a bus is on its right side only.
- Passenger access to a loading platform must accommodate individuals with disabilities.

### 1420.04(1) *Passengers*

To encourage use of the passenger access facility for an express transit stop, provide a route that is the shortest distance to travel from the park & ride lot or local transit stop. Failure to do so might generate the use of undesirable shortcuts. To encourage local use of the passenger access facilities, provide direct access from surrounding neighborhoods.

Provide grade separations for pedestrian access to transit stops in the median. Consider stairways, ramps, elevators, and escalators, but provide at least one access for the individuals with disabilities at every loading platform, as required by the American with Disabilities Act of 1990. (See Chapter 1510 for guidance when designing pedestrian grade separations.)

The ADA Accessibility Guidelines for Buildings and Facilities states, "Platform edges bordering a drop-off and not protected by platform screens or guard rails shall have a detectable warning ... 24 inches wide running the full length of the platform drop-off." (See the [Standard Plans](#) for the detectable warning pattern.)

At transit stops, at-grade crosswalks are only permitted in the at-grade crossing flyer stop layout described in [1420.02\(4\)\(a\)2](#). Use traffic calming techniques, such as horizontal alignment, textured pavement and crosswalk markings, barrier openings, and other treatments, to channelize pedestrian movements and slow the transit vehicle's movements. Illuminate transit stop crosswalks (see [Chapter 1040](#)).

Where at-grade crosswalks are not permitted, take steps to minimize unauthorized at-grade crossings. Fencing, taller concrete traffic barrier, enclosed walkways, and ramps are examples of steps that may be taken.

### 1420.04(2) *Bicycles*

Bike lanes on nearby streets and separate trails encourage people to bicycle from surrounding neighborhoods. Provide these bicyclists direct access to passenger access facilities.

Design bicycle access facilities in conjunction with the access for the individuals with disabilities (see Chapters [1510](#), [1515](#), and [1520](#)).

Locate bicycle parking outside of the passenger walkways (see [Chapter 1430](#)).

Locations near colleges and universities and locations with good bicycle access, especially near trails, will attract bicyclists. Contact the region Bicycle Coordinator for information on the predicted number of bicycle parking spaces needed and the types of bicycle racks available.

## 1420.05 Traffic Design Elements

Traffic design elements are critical to the safe and efficient use of HOV direct access facilities. The following discusses the elements of traffic design that might be different for HOV direct access facilities.

### 1420.05(1) *Traffic Barriers*

Separate the main line from the HOV direct access facilities with a traffic barrier. Whenever possible, separate opposing traffic lanes in the facility by using traffic barrier (see [Chapter 1610](#)). This is especially important in areas where opposing traffic is changing speeds to or from main line speeds. Concrete barrier is generally desirable on these facilities due to lower maintenance requirements.

Provide crashworthy end treatments to the approach ends of traffic barriers (see [Chapter 1620](#)).

When the operating speed is 25 mph or lower, and where an at-grade pedestrian crossing transit stop has an opening in a concrete barrier, a sloped-down end as shown in the [Standard Plans](#) is acceptable.

When providing a break in the barrier for turning maneuvers, consider sight distance (see [Chapter 1260](#)) when determining the location for stopping the barrier.

In areas where headlight glare is a concern, consider glare screens such as taller concrete barrier. Other glare screen options that mount on the top of a barrier tend to be high-maintenance items and are discouraged.

Taller barrier might also be desirable in areas where pedestrian access is discouraged, such as between opposing flyer stops or between a flyer stop and the main line.

### **1420.05(2) Signing**

Design and place HOV signing to clearly indicate whether the signs are intended for motorists in the HOV lane or the general-purpose lanes. The purposes of the signs are to:

- Enhance safety.
- Convey the message that HOV lanes are restricted to HOVs.
- Provide clear directions for entrances and exits.
- Define vehicle occupancy requirements or other restrictions.

Because HOV facilities are not found in many regions, the signing not only considers the commuter but also the occasional user of the facility who might be unfamiliar with the HOV facility and its operation.

#### **1420.05(2)(a) Safety**

Much of HOV signing relates to enhancing safety for motorists. Not only are geometrics often minimized due to the lack of right of way, but there are unusual operational characteristics such as the differential speed between the HOV vehicle and the adjacent general-purpose traffic. To allow for the lack of passing opportunities in the HOV lane and the necessity for frequent merging and weaving actions, use messages that are clear and concise, and use symbols wherever possible.

Because left-side off-connections are unusual, advance warning signing alerting motorists that an exit is on the left becomes more important.

For T ramps, provide traffic control at the T to assign priority to one of the turn movements and to avert wrong-way movements.

1510.01	General	1510.10	Crosswalks
1510.02	References	1510.11	Raised Medians/Traffic Islands
1510.03	Definitions	1510.12	Pedestrian Pushbuttons
1510.04	Policy	1510.13	At-Grade Railroad Crossings
1510.05	ADA Requirements by Project Type	1510.14	Pedestrian Grade Separations (Structures)
1510.06	Pedestrian Circulation Paths	1510.15	Other Pedestrian Facilities
1510.07	Pedestrian Access Routes (PARs)	1510.16	Illumination and Signing
1510.08	Sidewalks	1510.17	Work Zone Pedestrian Accommodation
1510.09	Curb Ramps	1510.18	Documentation

## 1510.01 General

Pedestrian travel is a vital transportation mode. It is used at some point by nearly everyone and is a critical link to everyday life for many. Designers must be aware of the various physical needs and abilities of pedestrians in order to ensure facilities provide universal access.

Section 504 of the Rehabilitation Act and the Americans with Disabilities Act of 1990 (ADA) require pedestrian facilities to be designed and constructed so they are readily accessible to and usable by persons with disabilities. This chapter provides accessibility criteria for the design of pedestrian facilities that meet applicable state and federal standards.

The pedestrian facilities included in a project are determined during the planning phase based on: access control of the highway; local transportation plans; comprehensive plans and other plans (such as Walk Route Plans developed by schools and school districts); the roadside environment; pedestrian volumes; user age group(s); and the continuity of local walkways along or across the roadway.

When developing pedestrian facilities within a limited amount of right of way, designers can be faced with multiple challenges. It is important that designers become familiar with the ADA accessibility criteria in order to appropriately balance intersection design with the often competing needs of pedestrians and other roadway users.

Similar to the roadway infrastructure, pedestrian facilities (and elements) require periodic maintenance in order to prolong the life of the facility and provide continued usability. Title II of the ADA requires that all necessary features be accessible and maintained in operable working condition for use by individuals with disabilities.

## 1510.02 References

### 1510.02(1) Federal/State Laws and Codes

[ADA](#) – 28 Code of Federal Regulations (CFR) Part 35, as revised September 15, 2010

[23 CFR Part 652](#), Pedestrians and Bicycle Accommodations and Projects

[49 CFR Part 27](#), Nondiscrimination on the Basis of Disability in Programs or Activities Receiving Federal Financial Assistance (Section 504 of the Rehabilitation Act of 1973 implementing regulations)

[Revised Code of Washington \(RCW\) 35.68](#), Sidewalks, gutters, curbs and driveways – All cities and towns

[RCW 35.68.075](#), Curb ramps for persons with disabilities – Required – Standards and Requirements

[RCW 46.04.160](#), Crosswalk (definition)

[RCW 46.61](#), Rules of the Road

[RCW 47.24.020](#), City streets as part of state highways – Jurisdiction, control

## 1510.02(2) Design Guidance

*ADA Standards for Accessible Design*, U.S. Department of Justice (USDOJ), 2010; consists of 28 CFR parts 35 & 36 and the *ADA and Architectural Barriers Act (ABA) Accessibility Guidelines for Buildings and Facilities* (ADA-ABAAG; also referred to as the 2004 ADAAG), July 23, 2004, U.S. Access Board as modified by USDOT for entities receiving USDOT funding per 49 CFR Part 27. (Applies to new construction or alterations as of November 29, 2006 for entities receiving USDOT funding per 49 CFR Part 27.) <sup>ⓘ</sup> <https://www.access-board.gov/guidelines-and-standards/transportation/facilities/ada-standards-for-transportation-facilities>

*ADA Standards for Transportation Facilities*, USDOT, 2006; consists of 49 CFR Parts 37, 38, & 39, the *ADA Accessibility Guidelines for Transportation Vehicles, September 6, 1991*, and the *ADA and ABA Accessibility Guidelines for Buildings and Facilities* (ADA-ABAAG; also referred to as the 2004 ADAAG), July 23, 2004, U.S. Access Board as modified by USDOT. (For transit, light rail, and similar public transportation facilities under Federal Transit Administration jurisdiction.)

<sup>ⓘ</sup> <https://www.access-board.gov/guidelines-and-standards/transportation/facilities/ada-standards-for-transportation-facilities>

<sup>ⓘ</sup> <https://www.access-board.gov/guidelines-and-standards/transportation/vehicles/adaag-for-transportation-vehicles>

*Department of Justice/Department of Transportation Joint Technical Assistance on the Title II of the Americans with Disabilities Act Requirements to Provide Curb Ramps when Streets, Roads, or Highways are Altered through Resurfacing*, USDOJ and USDOT, July 2013

<sup>ⓘ</sup> <http://www.ada.gov/doj-fhwa-ta.htm>

<sup>ⓘ</sup> <http://www.ada.gov/doj-fhwa-ta-glossary.htm>

<sup>ⓘ</sup> <https://www.ada.gov/doj-fhwa-ta-supplement-2015.html>

*Manual on Uniform Traffic Control Devices for Streets and Highways*, USDOT, FHWA; as adopted and modified by [Chapter 468-95 WAC](#) “Manual on uniform traffic control devices for streets and highways” (MUTCD) <sup>ⓘ</sup> [www.wsdot.wa.gov/publications/manuals/mutcd.htm](http://www.wsdot.wa.gov/publications/manuals/mutcd.htm)

*Revised Draft Guidelines for Accessible Public Rights-of-Way* (PROWAG), November 23, 2005, U.S. Access Board. The current best practices for evaluation and design of pedestrian facilities in the public right of way per the following FHWA Memoranda:

<sup>ⓘ</sup> [https://www.fhwa.dot.gov/environment/bicycle\\_pedestrian/resources/prwaa.cfm](https://www.fhwa.dot.gov/environment/bicycle_pedestrian/resources/prwaa.cfm)

<sup>ⓘ</sup> [http://www.fhwa.dot.gov/civilrights/memos/ada\\_memo\\_clarificationa.htm](http://www.fhwa.dot.gov/civilrights/memos/ada_memo_clarificationa.htm)

<sup>ⓘ</sup> <https://www.access-board.gov/guidelines-and-standards/streets-sidewalks/public-rights-of-way/background/revised-draft-guidelines>

*Standard Plans for Road, Bridge, and Municipal Construction (Standard Plans)*, M 21-01, WSDOT <sup>ⓘ</sup> [www.wsdot.wa.gov/publications/manuals/m21-01.htm](http://www.wsdot.wa.gov/publications/manuals/m21-01.htm)



### 1510.02(3) Supporting Information

*1991 ADA Standards for Accessible Design*, USDOJ; consists of 28 CFR parts 35 & 36 and the *ADA Accessibility Guidelines for Buildings and Facilities (ADAAG)*, July 1991, U.S. Access Board. (For buildings and on-site facilities: Expired for new construction and alterations. To be used only for evaluating the adequacy of new construction or alteration that occurred prior to November 29, 2006 for entities receiving USDOT funding per 49 CFR Part 27.)

🔗 <https://www.access-board.gov/guidelines-and-standards/buildings-and-sites/about-the-ada-standards/background/adaag>

*A Policy on Geometric Design of Highways and Streets (Green Book)*, AASHTO, Current version adopted by FHWA

*Field Guide for Accessible Public Rights of Way*, WSDOT, November 1, 2012

🔗 [http://www.wsdot.wa.gov/publications/fulltext/roadside/ada\\_field\\_guide.pdf](http://www.wsdot.wa.gov/publications/fulltext/roadside/ada_field_guide.pdf)

*Guide for the Planning, Design, and Operation of Pedestrian Facilities*, AASHTO, 2004. Provides guidance on the planning, design, and operation of pedestrian facilities along streets and highways. Specifically, the guide focuses on identifying effective measures for accommodating pedestrians on public rights of way. It can be purchased through the AASHTO website.

*Highway Capacity Manual*, Transportation Research Board (TRB), 2000

*Pedestrian Facilities Guidebook: Incorporating Pedestrians Into Washington's Transportation System*, OTAK, 1997 🔗 [www.wsdot.wa.gov/publications/manuals/fulltext/m0000/pedfacgb.pdf](http://www.wsdot.wa.gov/publications/manuals/fulltext/m0000/pedfacgb.pdf)

*Pedestrian Facilities Users Guide – Providing Safety and Mobility*, FHWA, 2002. Provides useful information regarding walkable environments, pedestrian crashes and their countermeasures, and engineering improvements for pedestrians.

🔗 <https://www.fhwa.dot.gov/publications/research/safety/01102/01102.pdf>

*Proposed Accessibility Guidelines for Pedestrian Facilities in the Public Right-of-Way*, July 26, 2011, U.S. Access Board. Federal Notice of Proposed Rule Making that gives a preview of potential future revisions to the PROWAG. 🔗 <https://www.access-board.gov/guidelines-and-standards/streets-sidewalks/public-rights-of-way/proposed-rights-of-way-guidelines>

“Special Report: Accessible Public Rights-of-Way – Planning & Design for Alterations,” Public Rights-of-Way Access Advisory Committee, July 2007

🔗 <https://www.access-board.gov/attachments/article/756/guide.pdf>

*Understanding Flexibility in Transportation Design – Washington*, WSDOT, 2005

🔗 [www.wsdot.wa.gov/research/reports/600/638.1.htm](http://www.wsdot.wa.gov/research/reports/600/638.1.htm)

Washington State Bicycle Facilities and Pedestrian Walkways Plan

🔗 [www.wsdot.wa.gov/bike/bike\\_plan.htm](http://www.wsdot.wa.gov/bike/bike_plan.htm)

*Terminal Design Manual*, Chapter 300 Accessibility, WSDOT, Washington State Ferries Division 🔗 [www.wsdot.wa.gov/publications/manuals/m3082.htm](http://www.wsdot.wa.gov/publications/manuals/m3082.htm)

### 1510.03 Definitions

Refer to the *Design Manual Glossary* for definitions of many of the terms used in this chapter.

## 1510.04 Policy

### 1510.04(1) General

It is WSDOT policy to provide appropriate pedestrian facilities along and across sections of state routes as an integral part of the transportation system. Federal Highway Administration (FHWA) and WSDOT policy is that bicycle and pedestrian facilities be given full consideration in the planning and design of new construction and reconstruction highway projects, except where bicycle and pedestrian use is prohibited.

### 1510.04(2) Jurisdiction

Proposed projects in public rights of way must address ADA compliance as described in this chapter. (See [1510.05](#) for ADA requirements by project type.) Regardless of which public agency has jurisdiction within the right of way, the public agency that is sponsoring the project is responsible for ensuring ADA compliance is addressed on its project.

On all state routes outside of incorporated cities and on those with limited access (full, partial, and modified) within incorporated cities, jurisdiction remains with the state unless modified by a maintenance agreement. In turnback areas where the turnback agreement has not been completed, the state maintains full jurisdiction (see Chapters [510](#), [520](#), and [530](#)).

When project work occurs on a managed access state route inside an incorporated city that has jurisdiction beyond the curbs ([RCW 47.24.020](#)), design pedestrian facilities using the city design standards adopted in accordance with [RCW 35.78.030](#) and the most current ADA requirements. Document the coordination with the city in the Design Documentation Package (DDP). Refer to [Chapter 300](#) for information about the DDP.

### 1510.04(3) Transition Planning

Section 504 of the Rehabilitation Act and the ADA require all public entities to conduct a self-evaluation of their programs and activities, including sidewalks, curb ramps, and other pedestrian facilities and elements within the public right of way, to determine if barriers exist that prevent people with disabilities from being able to access these programs and activities.

If barriers are identified, agencies with 50 or more employees must develop and implement a transition plan that describes the barriers, the modifications needed, and a schedule for when the needed work will be accomplished.

### 1510.04(4) Maintenance

As noted in [1510.01](#), Title II of the ADA requires that a public entity maintain in operable working condition those features of facilities and equipment that are required to be readily accessible to and usable by persons with disabilities.

## 1510.05 ADA Requirements by Project Type

Wherever pedestrian facilities are intended to be a part of the transportation facility, federal regulations ([28 CFR Part 35](#)) require that those pedestrian facilities meet ADA guidelines. All new construction or alteration of existing transportation facilities must be designed and constructed to be accessible to and usable by persons with disabilities. FHWA is one of the federal agencies designated by the Department of Justice to ensure compliance with the ADA for transportation projects.

### **1510.05(1) New Construction Projects**

New construction projects address the construction of a new roadway, interchange, or other transportation facility where none existed before. For these projects, pedestrians' needs are assessed and included in the project. All pedestrian facilities included in these projects must fully meet the accessibility criteria when built.

### **1510.05(2) Alteration Projects**

Any project that affects or could affect the usability of a pedestrian facility is classified as an alteration project. Alteration projects include, but are not limited to, renovation; rehabilitation; reconstruction; historic restoration; resurfacing of circulation paths or vehicular ways; and changes or rearrangement of structural parts or elements of a facility. Where existing elements or spaces are altered, each altered element or space within the limits of the project shall comply with the applicable accessibility requirements to the maximum extent feasible.

The following are some examples of project types that are classified as alteration projects and can potentially trigger a variety of ADA requirements:

- HMA overlay or inlay
- Traffic signal installation or retrofit
- Roadway widening
- Realignment of a roadway (vertical or horizontal)
- Sidewalk improvements
- PCCP panel repair/replacement
- Bridge replacement
- Raised channelization

The following are not considered alterations:

- Spot pavement repair
- Liquid-asphalt sealing, chip seal (BST), or crack sealing
- Lane restriping that does not alter the usability of the shoulder

If there is uncertainty as to whether a project meets the definition of an alteration project, consult with the Regional ADA [Liaison](#).

The following apply to alteration projects:

- All new pedestrian facilities included in an alteration project that are put in place within an existing developed right of way must meet applicable accessibility requirements to the maximum extent feasible.
- All existing pedestrian facilities disturbed by construction of an alteration project must be replaced. The replacement facilities must meet applicable accessibility requirements to the maximum extent feasible.
- An alteration project shall not decrease or have the effect of decreasing the accessibility of a pedestrian facility or an accessible connection to an adjacent building or site below the ADA accessibility requirements in effect at the time of the alteration.
- Within the construction impact zone of an alteration project, any existing connection from a pedestrian access route to a crosswalk (marked or unmarked) that is missing a required curb ramp must have a curb ramp installed that meets applicable accessibility requirements to the maximum extent feasible. (See [1510.09\(2\)](#) for curb ramp accessibility criteria.)

- A crosswalk served by a curb ramp must also have an existing curb ramp in place on the receiving end unless there is no curb or sidewalk on that end of the crosswalk ([RCW 35.68.075](#)). If there is no existing curb ramp in place on the receiving end, an accessible curb ramp must be provided. This requirement must be met regardless of whether the receiving end of the crosswalk is located within the project's limits.
- Within the construction impact zone of an alteration project, evaluate all existing curb ramps to determine whether curb ramp design elements meet the accessibility criteria. (See [1510.09\(2\)](#) for curb ramp accessibility criteria.) Modify existing curb ramps that do not meet the accessibility criteria to meet applicable accessibility requirements to the maximum extent feasible. This may also trigger modification of other adjacent pedestrian facilities to incorporate transitional segments in order to ensure specific elements of a curb ramp will meet the accessibility criteria.
- Within the construction impact zone of an alteration project that includes hot mix asphalt overlay (or inlay) of an existing roadway and *does not* include reconstruction, realignment, or widening of the roadway, evaluate all existing marked and unmarked crosswalks. (See [1510.10\(2\)](#) for crosswalk accessibility criteria.) If it is not possible to meet the applicable accessibility requirements for crosswalks, document this in the DDP.
- Within the construction impact zone of an alteration project that includes reconstruction, realignment, or widening of the roadway, evaluate all existing crosswalks (marked or unmarked) to determine whether crosswalk design elements meet the accessibility criteria. (See [1510.10\(2\)](#) for crosswalk accessibility criteria.) Modify crosswalk slopes to meet the applicable accessibility requirements to the maximum extent feasible.

It may not always be possible to fully meet the applicable accessibility requirements during alterations of existing facilities. If such a situation is encountered, consult with the Regional ADA [Liaison](#) to develop a workable solution to meet the accessibility requirements to the maximum extent feasible. Cost is not to be used as a justification for not meeting the accessibility criteria. Physical terrain or site conditions that would require structural impacts, environmental impacts, or unacceptable impacts to the community in order to achieve full compliance with the accessibility criteria are some of the factors that can be used to determine that the maximum extent feasible is achieved. If it is determined to be virtually impossible to meet the accessibility criteria for an element, document the decision in one of the following ways, as applicable:

- Within the construction impact zone of an alteration project that does not include reconstruction, realignment, or widening of the roadway, document the following deficient elements in the DDP:
  - Perpendicular curb ramp or parallel curb ramp landing cross slope that is constrained by the existing roadway gutter profile and exceeds 2%, but is less than or equal to 5%, that cannot be constructed to fully meet applicable accessibility requirements.
  - Flared side of a perpendicular curb ramp that is constrained by the existing roadway gutter profile and has a slope that exceeds 10%, but is less than or equal to 16.7%, that cannot be constructed to fully meet applicable accessibility requirements.
  - For any deficient element that does not match the preceding description, document the decision via a stamped and signed Maximum Extent Feasible (MEF) document. The MEF document will be reviewed by the appropriate Assistant State Design Engineer (ASDE) and the Headquarters (HQ) ADA Compliance Manager. If acceptable, the MEF document will be approved and included in the DDP.

### 1510.05(2)(a) Requirements for Crossings with Pedestrian Pushbuttons

Coordinate sidewalk and curb ramp work with signal system work so that signal poles with pedestrian equipment meet accessibility requirements for APS pushbuttons to the maximum extent feasible. See [1510.12](#) for additional information on pedestrian pushbutton accessibility.

For existing signal systems only, the work required for each signal system location is determined as follows:

1. If no sidewalk ramp work is being performed at a signal system location, no work is required for that signal system as part of the project.
2. If any ramp is being reconstructed at a signal system location, and the traffic signal system is owned by WSDOT, then all poles with pedestrian equipment shall be made accessible for the entire traffic signal system at that location. This may require new or relocated poles, as well as additional ramp and sidewalk work beyond that previously described in [1510.05\(2\)](#).
3. If any ramp is being reconstructed at a signal system location, and the traffic signal system is owned by another agency, only poles with pedestrian pushbuttons serving a crossing served by a ramp that is being reconstructed are required to be made accessible as part of the project. This may require reconstruction of the ramps, landings, or sidewalk areas at both ends of the crossing. The remaining crossings and poles may be addressed if the owning agency wishes to provide funding for the additional work.

If APS pushbuttons are not being installed as part of a project, any revised pole locations shall be designed to meet accessibility requirements with a conventional pushbutton installed and with an APS pushbutton installed, so that the pole does not have to be relocated when the conventional pushbutton is replaced with an APS pushbutton. Typically a location that is accessible with an APS pushbutton installed will be accessible with a conventional pushbutton installed, but verification is required.

Locations where these requirements cannot be fully met shall follow the procedures for maximum extent feasible documentation as previously described.

### 1510.06 Pedestrian Circulation Paths (PCP)

PCP are prepared exterior or interior ways of passage provided for pedestrian travel. They include independent walkways, sidewalks, shared-use paths, and other types of pedestrian facilities. Pedestrian circulation paths can either be immediately adjacent to streets and highways or separated from them by a buffer. Examples of PCP are shown in [Exhibit 1510-1](#).

When the PCP is located behind guardrail, address protruding bolts. Installing a rub rail or a “W-beam” guardrail on the pedestrian side of the posts can mitigate potential snagging and also serve as a guide for sight-impaired pedestrians.

Provide a smooth finish to vertical surfaces adjacent to a PCP to mitigate potential snagging or abrasive injuries from accidental contact with the surface. Where adjacent walkway segments diverge, such as can occur if a parallel curb ramp does not occupy the entire width of a PCP, any resulting drop-offs must be protected to prevent trips or falls.

When relocation of utility poles and other fixtures is necessary for a project, determine the impact of their new location on all PCP. Look for opportunities to relocate obstructions, such as existing utility objects, away from the PCP.





### Pedestrian Circulation Paths

#### Exhibit 1510-1

Highway shoulders are an extension of the roadway and are not typically considered pedestrian facilities. Pedestrians are allowed to use many state highways. Although pedestrians are allowed to travel along the shoulder in these cases, its main purpose is to provide an area for disabled vehicles, a recovery area for errant vehicles, and positive drainage away from the roadway.

Shoulders may serve as a pedestrian facility when sidewalks are not provided. If pedestrian generators, such as bus stops, are present and pedestrian usage is evident, a 4-foot-wide paved shoulder is adequate. Note that detectable warning surfaces should not be installed where a sidewalk ends and pedestrians are routed onto a shoulder since the shoulder is not a vehicular traveled way.

Where pedestrian traffic is evident, consider a separate PCP during the planning and programming of the project. Consult with the State Bicycle and Pedestrian Coordinator.

#### 1510.06(1) Accessibility Criteria for Pedestrian Circulation Paths

The following criteria apply across the entire width of the PCP, not just within the pedestrian access route.

##### 1510.06(1)(a) Vertical Clearance

- The minimum vertical clearance for objects that protrude into or overhang a pedestrian circulation path is 80 inches.
- If the minimum vertical clearance cannot be provided, railings or other barriers shall be provided. The leading bottom edge of the railing or barrier shall be located 27 inches maximum above the finished surface for cane detection.

*Note:* Per the [MUTCD](#), the vertical clearance to the bottom of signs is 7 feet (84 inches.)

##### 1510.06(1)(b) Horizontal Encroachment

- Protruding objects on PCPs shall not reduce the clear width of the pedestrian access route to less than 4 feet, exclusive of the curb.

*Note:* If an object must protrude farther than 4 inches into a PCP at a height that is greater than 27 inches and less than 80 inches above the finished surface, then it must be equipped with a warning device that is detectable by a vision-impaired person who navigates with a cane. The minimum clear width of the PAR must still be provided.

**1510.06(1)(c) Post-Mounted Objects**

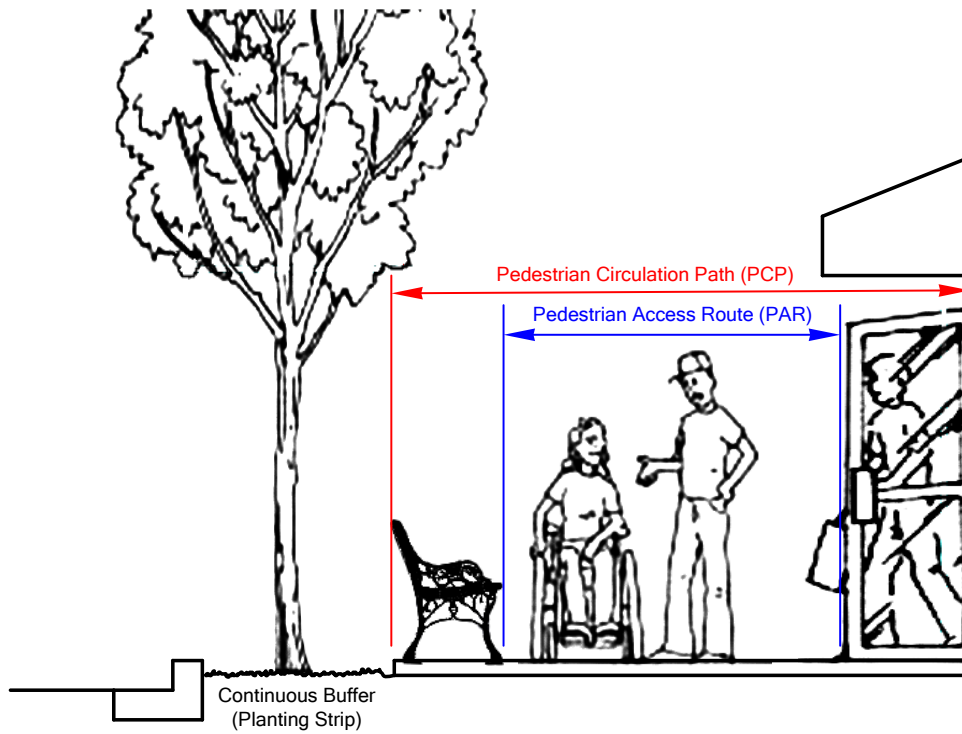
- Objects mounted on posts, at a height that is greater than 27 inches and less than 80 inches above the finished surface, shall not protrude more than 4 inches into a pedestrian circulation path.

*Note:* If an object must protrude farther than 4 inches into a pedestrian circulation path at a height that is greater than 27 inches and less than 80 inches above the finished surface, then it must be equipped with a warning device that is detectable by a vision-impaired person who navigates with a cane. The minimum clear width of the pedestrian access route must still be provided.

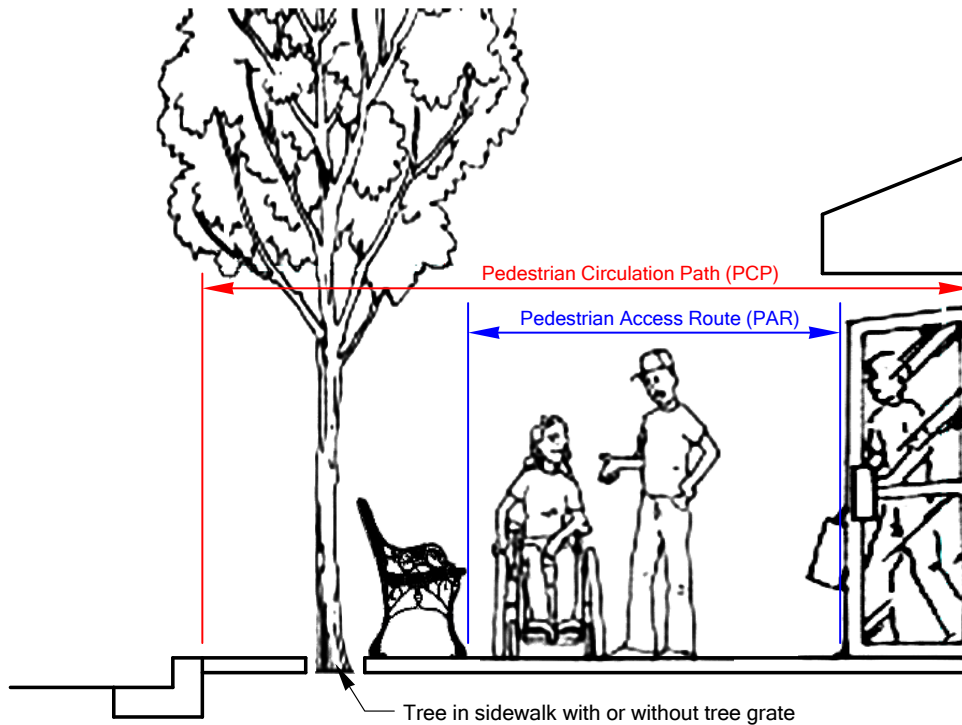
- Where a sign or other obstruction on a pedestrian circulation path is mounted on multiple posts, and the clear distance between the posts is greater than 12 inches, the lowest edge of the sign or obstruction shall be either 27 inches maximum or 80 inches minimum above the finished surface.

**1510.07 Pedestrian Access Routes (PARs)**

All PCPs are required to contain a continuous PAR (see [Exhibit 1510-2](#)) that connects to all adjacent pedestrian facilities, elements, and spaces that are required to be accessible. PARs consist of one or more of the following pedestrian facilities: walkways/sidewalks, crosswalks, curb ramps (excluding flares), landings, pedestrian overpasses/underpasses, access ramps, elevators, and platform lifts.



With Continuous Buffer



Without Continuous Buffer

**Relationship Between Pedestrian Circulation Paths and Pedestrian Access Routes**  
*Exhibit 1510-2*



### 1510.07(1) Accessibility Criteria for Pedestrian Access Routes

#### 1510.07(1)(a) Clear Width

- The minimum continuous and unobstructed clear width of a PAR shall be 4 feet, exclusive of the width of the curb.
- PARs that are less than 5 feet in clear width, exclusive of the width of the curb, shall provide passing spaces at intervals no farther apart than 200 feet. Passing spaces shall be 5 feet wide minimum, for a minimum distance of 5 feet.



**Note:** Provide wheel stops or a wider sidewalk to remedy the encroachment into the PAR.

#### Obstructed Pedestrian Access Route

*Exhibit 1510-3*

#### 1510.07(1)(b) Cross Slope and Grade

- The cross slope of a PAR shall be 2% maximum.

**Note:** It is recommended that cross slopes be designed to be less than the allowed maximum to allow for some tolerance in construction. For example: design for a maximum 1.5% cross slope (rather than 2% maximum).

**Exceptions:**

1. Midblock crosswalks – The cross slope of the crosswalk and any connected curb ramp is permitted to match street or highway grade.
  2. Crosswalks without stop sign control – The cross slope of the crosswalk can be up to 5% maximum.
- Where a PAR is contained within the highway right of way, its grade shall not exceed the general grade established for the adjacent roadway.

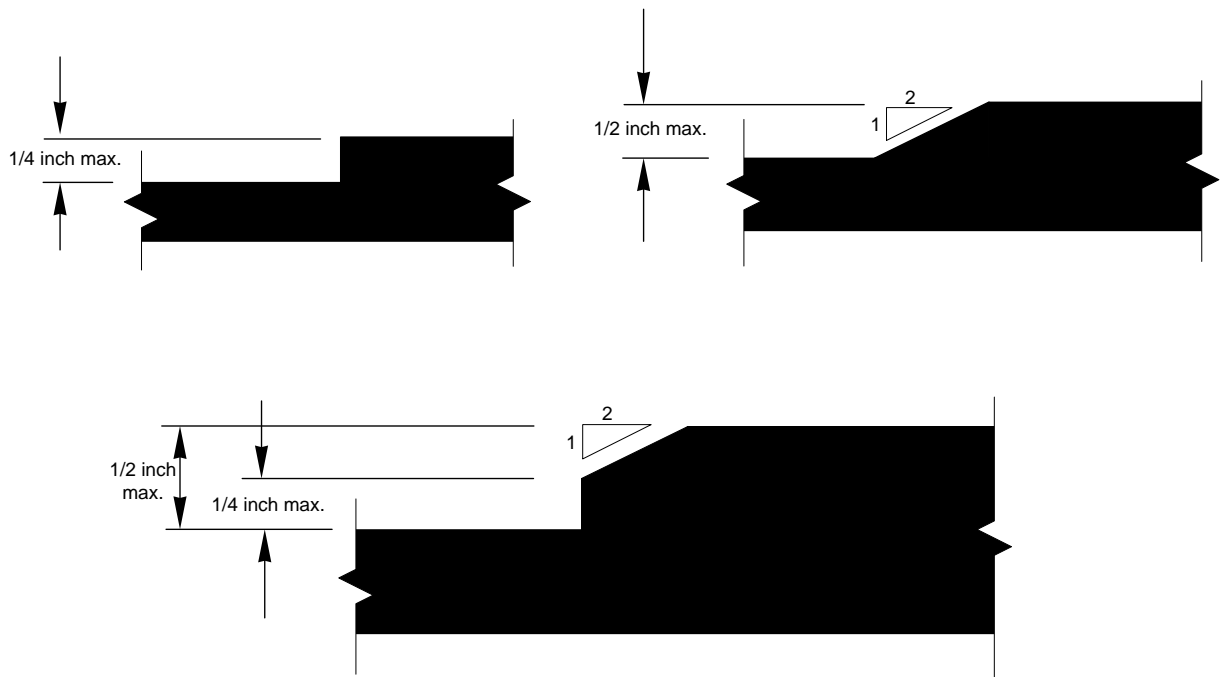
**Exception:** The maximum grade in a crosswalk (marked or unmarked) is 5%, measured parallel to the direction of pedestrian travel in the crosswalk.

- Where a PAR is not contained within the highway right of way, the maximum running slope allowed is 5% unless designed as an access ramp. (See [1510.15\(2\)](#) for access ramp accessibility criteria.)
- For additional criteria when a PAR is supported by a structure, see [1510.14](#).

**1510.07(1)(c) Surface**

- The surface of the PAR shall be firm, stable, and slip resistant. Use hard surfaces like cement or asphalt concrete; crushed gravel is not considered to be a stable, firm surface.
- Vertical alignment shall be planar within curb ramps, landings, and gutter areas within the PAR and within clear spaces for accessible pedestrian signals, street furniture, and operable parts.
- Grade breaks shall be flush.
- Surface discontinuities (see Exhibits 1510-4 and 1510-5) on existing surfaces in the pedestrian access route (such as at the joints of settled or upheaved sidewalk panels) may not exceed 1/2 inch maximum. Vertical discontinuities between 1/4 inch and 1/2 inch maximum shall be beveled at 2H:1V or flatter. Apply the bevel across the entire level change.

**Exception:** No surface discontinuity is allowed at the connection between an existing curb ramp or landing and the gutter. This grade break must be flush.



**Beveling Options**  
Exhibit 1510-4



### Surface Discontinuities (Noncompliant)

*Exhibit 1510-5*

- Gratings, access covers, utility objects, and other appurtenances shall not be located on curb ramps, landings, or gutters within the PAR.
- Locate gratings, access covers, utility objects, and other appurtenances outside the PAR on walkways and sidewalks. Where this is not possible, ensure covers, grates, and lids are designed to be slip resistant and are installed flush with the surrounding surface (see the [Standard Plans](#)).

#### 1510.07(1)(d) Horizontal Openings

- Any sidewalk joints or gratings that are in the PAR shall not permit passage of a sphere more than ½ inch in diameter.
- Elongated openings shall be placed so that the long dimension is perpendicular to the dominant direction of travel.
- Openings for wheel flanges at pedestrian crossings of nonfreight rail track shall be 2½ inches maximum (3 inches maximum for freight rail track).
- For additional requirements when a PAR crosses a railroad, see [1510.13](#).

#### 1510.08 Sidewalks

Sidewalks are one type of PCP. (See [1510.06](#) for PCP accessibility criteria.) Plan the design of sidewalks carefully to include a PAR that provides universal access. (See [1510.07](#) for PAR accessibility criteria.) Sidewalk design elements are found in [Exhibit 1510-7](#) and details for raised sidewalks are shown in the [Standard Plans](#). Wherever appropriate, make sidewalks continuous and provide access to side streets. The most pleasing and comfortable installation for the pedestrian is a sidewalk separated from the traveled way by a planted buffer. This provides a greater separation between vehicles and pedestrians than curb alone.

### 1510.08(1) Sidewalk and Buffer Widths

The WSDOT minimum sidewalk width is 5 feet (excluding the curb), but providing wider sidewalks is encouraged. Wider sidewalks are desirable on major arterials, in central business districts, and along parks, schools, and other major pedestrian generators. When sidewalks abut storefronts, additional width should be provided to accommodate window-shoppers and to avoid conflicts with opening doors and pedestrians entering or leaving the buildings.

When a buffer (vegetated as well as alternate pavement) is provided, the buffer should be at least 3 feet wide (excluding the curb). Document the decision to reduce a buffer width to less than 3 feet in the DDP.

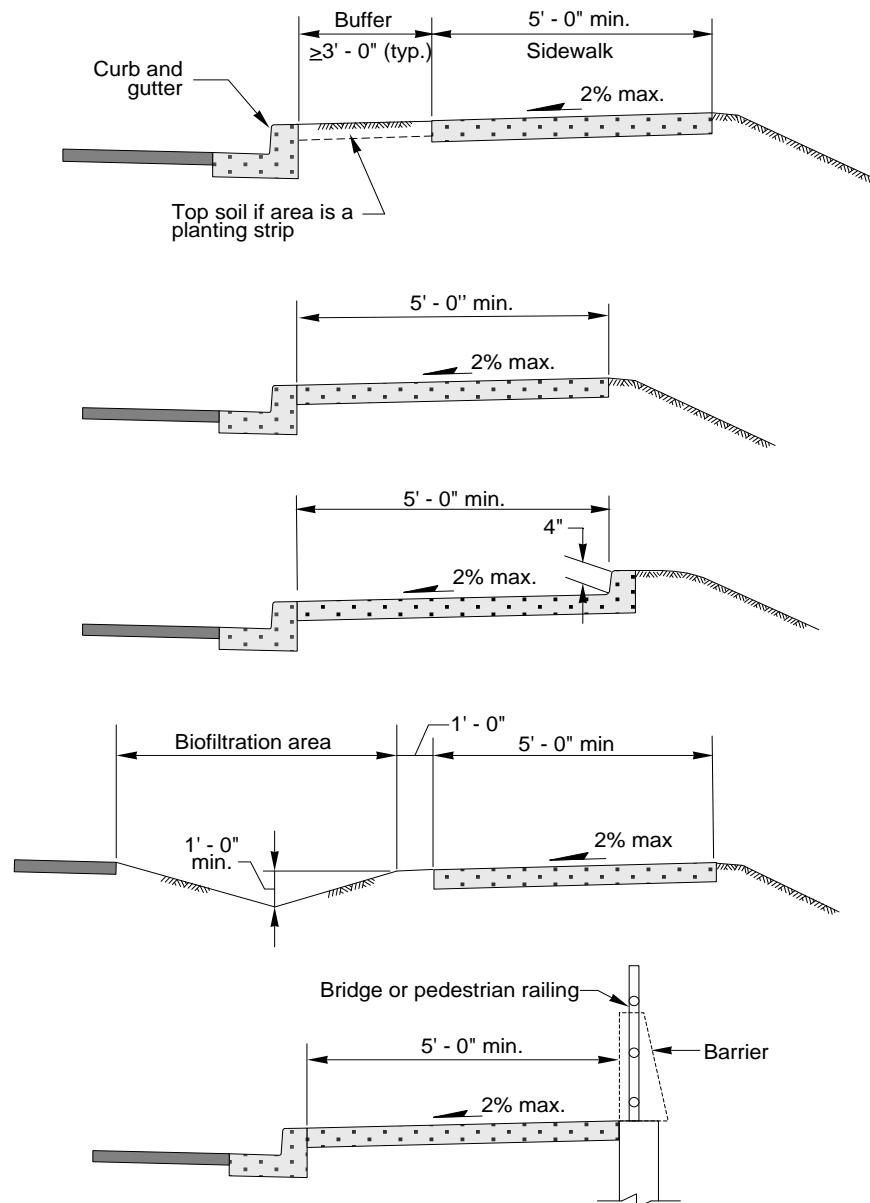
If trees or shrubs are included in a buffer, coordinate with the region or HQ Landscape Architect. Take into account Design Clear Zone guidelines (see [Chapter 1600](#)). Design subsurface infrastructure (such as structural soils) and select plants whose root systems do not cause sidewalks to buckle or heave. Coordinate buffer planting with maintenance personnel.

Where possible, strive to accommodate snow storage while keeping the pedestrian route free of snow accumulation. Make sure maintenance access is not obstructed. Shoulders, bike lanes, and on-street parking are not considered buffers, but they do offer the advantage of further separation between vehicles and pedestrians.



**Sidewalks With Buffers**

*Exhibit 1510-6*

**Notes:**

If vertical drop is within the Design Clear Zone and the posted speed is > 35 mph, then barrier may be needed (see [Chapter 1600](#)).

If vertical drop is  $\geq$  2 feet 6 inches and barrier is not needed, then railing is indicated.

If vertical drop is < 2 feet 6 inches and barrier is not needed, then a 4-inch curb at back of sidewalk is adequate.

**General:**

See the [Standard Plans](#) for details on slopes at back of sidewalk.

See [Chapter 1230](#) for slope selection criteria.

Sidewalks may be sloped away from the roadway for stormwater treatment (see the [Highway Runoff Manual](#)).

### Typical Sidewalk Designs

*Exhibit 1510-7*



### 1510.08(2) Sidewalks at Driveways

Provide a PAR where driveways intersect a PCP (see [Exhibit 1510-8](#)). The *Standard Plans* shows details of driveway designs that provide a PAR. (See [1510.06](#) and [1510.07](#) for accessibility criteria.) When a driveway is signalized as part of an intersection, contact the Region ADA [Liaison](#) for guidance.



**Typical Driveways**  
*Exhibit 1510-8*

### 1510.09 Curb Ramps

Curb ramps provide an accessible connection from a raised sidewalk down to the roadway surface. A curb ramp, or combination of curb ramps, is required to connect PAR to crosswalks (marked or unmarked) where curbs and sidewalks are present, except where pedestrian crossing is prohibited. (See [1510.10\(2\)\(c\)](#) for guidance on closed crossings and [Exhibit 1510-17](#) for an example.)

For new construction projects, provide a curb ramp oriented in each direction of pedestrian travel within the width of the crosswalk it serves. For alteration projects, a curb ramp oriented in each direction of pedestrian travel within the width of the crosswalk it serves is desirable.

Every curb ramp must have a curb ramp at the other end of the crosswalk it serves unless there is no curb or sidewalk on that side ([RCW 35.68.075](#)).

Curb ramps are also required at midblock crossings where curbs and sidewalks are present.

#### 1510.09(1) Types of Curb Ramps

Different types of curb ramps can be used: perpendicular, parallel, and combination. Carefully analyze and take into consideration drainage patterns, especially when designing a parallel or combination curb ramp installation.

### 1510.09(1)(a) Perpendicular Curb Ramp

Perpendicular curb ramps (see [Exhibits 1510-9](#) and [1510-10](#)) are aligned to cut through the curb and meet the gutter grade break at a right angle. The landing is to be located at the top of the curb ramp.

#### 1. Advantages

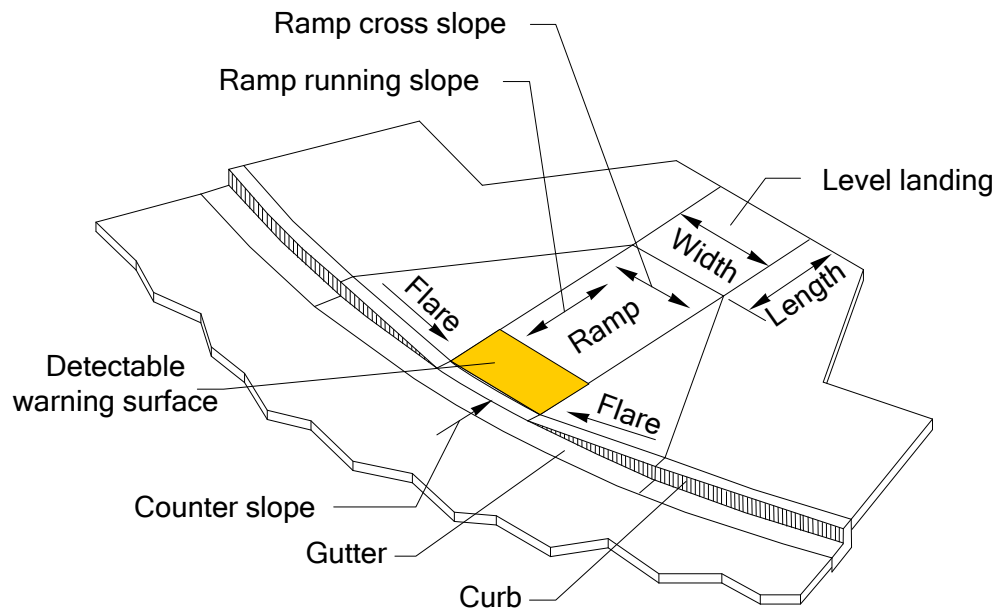
- Having the path of travel aligned to cross the gutter grade break at a right angle facilitates usage by individuals with mobility devices.
- The height of the ramp run relative to the gutter elevation may facilitate drainage.
- The height of the ramp run relative to the gutter elevation discourages vehicular traffic from cutting across the corner.
- On small-radius corners, the ramp alignment may be more closely aligned with the alignment of the crosswalk markings, which facilitates direction finding for the visually impaired.

#### 2. Disadvantages

- The ramp run and landing might not fit within available right of way.
- On small-radius corners, the flares may not fit between closely spaced perpendicular curb ramps.
- On larger-radius corners, there will be less facilitation of direction finding for the visually impaired due to the requirement that the path of travel cross the gutter grade break at a right angle.



**Perpendicular Curb Ramp**  
*Exhibit 1510-9*



### Perpendicular Curb Ramp Common Elements

*Exhibit 1510-10*

#### 1510.09(1)(b) Parallel Curb Ramp

Parallel curb ramps (see [Exhibits 1510-11](#) and [1510-12](#)) are aligned with their running slope in line with the direction of sidewalk travel, parallel to the curb. The landing is located at the bottom of the curb ramp.

##### 1. Advantages

- Requires minimal right of way.
- Allows ramps to be extended to reduce ramp grade within available right of way.
- Provides edges on the side of the ramp that are detectable to vision-impaired pedestrians who navigate with a cane.

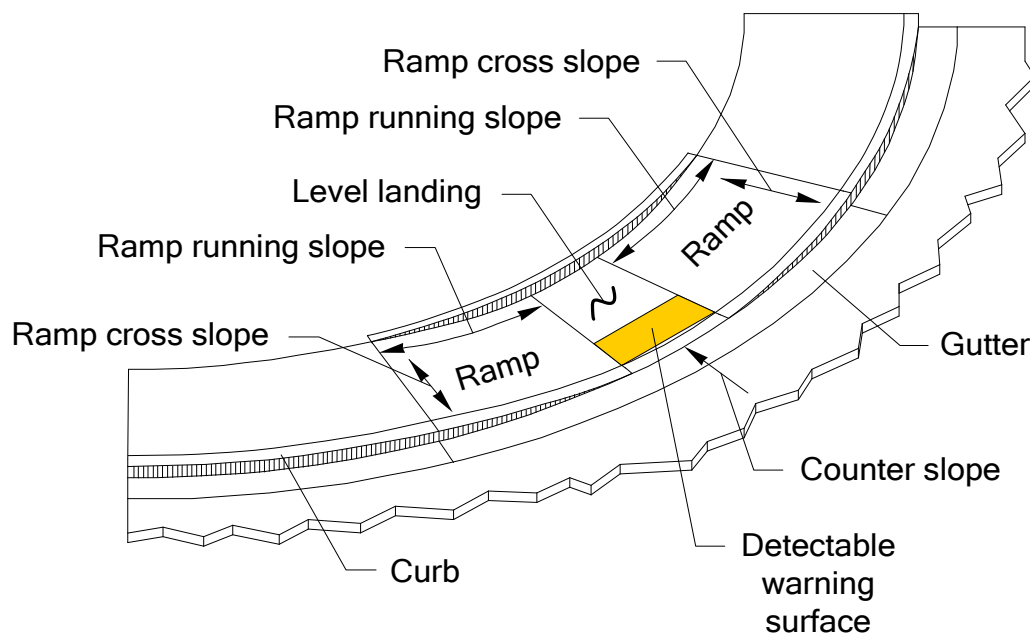
##### 2. Disadvantages

- Depending on the style of parallel curb ramp, pedestrian through traffic on the sidewalk may need to negotiate two ramp grades instead of one, possibly making it more difficult to traverse for some.
- The installation of additional drainage features in the upstream gutter line may be necessary to prevent the accumulation of water or debris in the landing at the bottom of the ramp.





**Parallel Curb Ramp**  
*Exhibit 1510-11*



**Note:** The pedestrian curb shown on the back of the curb ramp is intended to retain material in a cut section and is not required if there is no material to retain due to the nature of the roadside topography.

**Parallel Curb Ramp Common Elements**  
*Exhibit 1510-12*

### 1510.09(1)(c) Combination Curb Ramp

Combination curb ramps (see [Exhibit 1510-13](#)) combine the use of perpendicular and parallel types of curb ramps. Landings may be shared by multiple ramps in this application. Buffer areas and pedestrian curbing that define the pedestrian path of travel are inherent design elements for this type of curb ramp.

#### 1. Advantages

- Allows the elevation difference between the sidewalk and the gutter line to be transitioned with multiple ramps. This can help achieve compliant ramp running slopes.
- Provides additional locations in the gutter line along the radius where drainage structures can be placed outside the pedestrian access route due to the well-defined pedestrian paths of travel.
- Can be constructed within available right of way when the right of way boundary is located at the back of the existing sidewalk, provided sufficient buffer width is available on the roadway side of the sidewalk.
- Provides a way to avoid the relocation of existing features such as utility poles, fire hydrants, and signal poles by incorporating those features into the buffer areas.
- The pedestrian curbing that defines the buffer areas and forms the curb returns for the perpendicular ramp connections facilitates direction finding for a vision-impaired person who navigates with a cane.

#### 2. Disadvantages

- Has a higher construction cost than other curb ramp types due to extensive use of curbing and a larger footprint.
- Due to generally flatter ramp grades and multi-tiered ramp elements, inadequate drainage and accumulation of debris can occur.



**Combination Curb Ramps**  
*Exhibit 1510-13*

### 1510.09(2) Accessibility Criteria for Curb Ramps

The accessibility criteria for PCPs and PARs described in 1510.06 and 1510.07 also apply to curb ramps, except where superseded by the following additional accessibility criteria specifically for curb ramps.

#### 1510.09(2)(a) Clear Width

- The clear width of curb ramps and their landings shall be 4 feet minimum, excluding flares.

#### 1510.09(2)(b) Running Slope

- The running slope of curb ramps shall not exceed 8.3% maximum.

*Note:* It is recommended that running slopes be designed to be less than the allowed maximum to allow for some tolerance in construction. For example, design for a maximum 7.5% curb ramp running slope (rather than the 8.3% maximum).

- The running slope of a perpendicular curb ramp shall intersect the gutter grade break at a right angle at the back of curb.
- If the maximum running slope of 8.3% cannot be achieved due to existing physical constraints, the ramp shall be as flat as possible but the ramp length is not required to exceed 15 feet.

#### 1510.09(2)(c) Cross Slope

- The cross slope of curb ramp shall not be greater than 2%, measured perpendicular to the direction of travel.

*Note:* It is recommended that cross slopes be designed to be less than the allowed maximum to allow for some tolerance in construction. For example, design for a maximum 1.5% cross slope (rather than the 2% maximum).

*Exception:* The cross slopes of curb ramps at midblock crossings are permitted to match the street or highway grade.

#### 1510.09(2)(d) Landing

A level landing is required either at the top of a perpendicular ramp or the bottom of a parallel curb ramp, as noted in 1510.09(1)(a) and (b) for the type of curb ramp used.

- Provide a landing that is at least 4 feet minimum length by 4 feet minimum width.
- The running and cross slopes of a curb ramp landing shall be 2% maximum.

*Note:* It is recommended that cross slopes be designed to be less than the allowed maximum to allow for some tolerance in construction. For example, design for a maximum 1.5% cross slope (rather than 2% maximum).

*Exception:* The running and cross slopes of landings for curb ramps at midblock crossings are permitted to match the street or highway grade.

**1510.09(2)(e) Flares**

- Flared sides are to be used only where a PCP crosses the curb ramp from the side.
- Flared sides are to have a slope of 10% maximum, measured parallel to the back of curb.

**1510.09(2)(f) Counter Slope**

- The counter slope of the gutter or street at the foot of a curb ramp or landing shall be 5% maximum.

**1510.09(2)(g) Detectable Warning Surfaces**

- Detectable warning surfaces are required where curb ramps or landings connect to a roadway. (See the *Standard Plans* for placement details and other applications.)
- Detectable warning surfaces shall contrast visually (either light-on-dark or dark-on-light) with the adjacent walkway surface, gutter, street, or highway.

*Note:* Federal yellow is the color used to achieve visual contrast on WSDOT projects. Within cities, other contrasting colors may be used if requested by the city.

**1510.09(2)(h) Surfaces**

- Surfaces of curb ramps shall be firm, stable, and slip resistant.
- Gratings, access covers, utility objects, and other appurtenances shall not be located on curb ramps, landings, or gutters within the pedestrian access route.

**1510.09(2)(i) Grade Breaks**

- Vertical alignment shall be planar within curb ramp runs, landings, and gutter areas within the PAR.
- Grade breaks at the top and bottom of curb ramps shall be perpendicular to the direction of travel on the ramp run.
- Surface slopes that meet at grade breaks shall be flush.

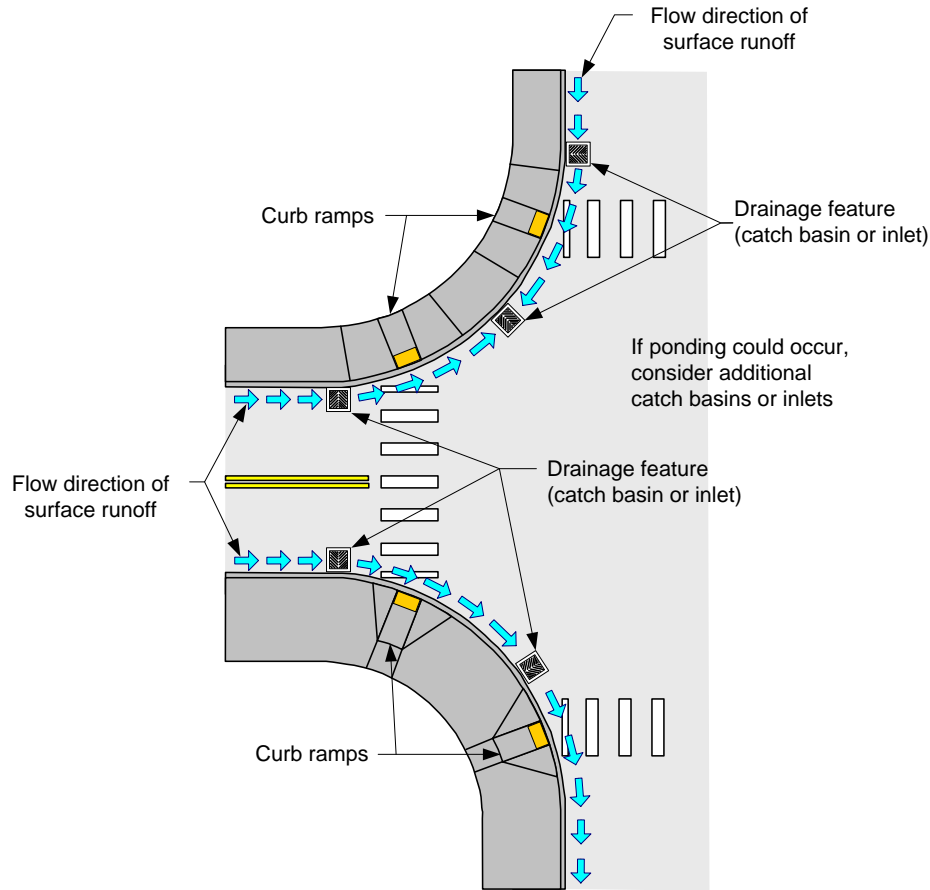
**1510.09(2)(j) Clear Space**

- Beyond the curb face where the bottom of a curb ramp or landing meets the gutter, a clear space of 4 feet minimum by 4 feet minimum shall be provided in the roadway that is contained within the width of the crosswalk and located wholly outside the parallel vehicle travel lane.

*Note:* Clear space is easily achieved when a separate curb ramp is provided, oriented in each direction of pedestrian travel within the width of the crosswalk it serves.

**1510.09(3) Curb Ramp Drainage**

Surface water runoff from the roadway can flood the lower end of a curb ramp. Provide catch basins or inlets to prevent ponding at the base of curb ramps and landings. [Exhibit 1510-14](#) shows examples of drainage structure locations. Verify that drainage structures will not be located in the PAR.



**Typical Curb Ramp Drainage**  
Exhibit 1510-14

## 1510.10 Crosswalks

### 1510.10(1) Designing Crossing Facilities

Evaluate the following for crossing facilities to address the needs of all user modes:

- Minimize turning radii to keep speeds low. (See [Chapter 1300](#) for design vehicle guidance.)
- Place crosswalks so they are visible and connect to the adjacent pedestrian facilities.
- Provide sight distance (driver to pedestrian; pedestrian to driver).
- Use a separate left-turn phase along with a “WALK/DON’T WALK” signal.
- Restrict or prohibit turns.
- Shorten crossing distance.
- Use a raised median/cut-through island for a pedestrian refuge.
- Use accessible pedestrian signals (APS).
- Use signing and delineation as determined by the region Traffic Engineer.
- Place crosswalks as close as practicable to the intersection traveled way.
- Provide pedestrian-level lighting.
- Consider the crosswalk location in relation to transit stops.
- Provide a PAR that meets the accessibility criteria at all pedestrian crossings.

**1510.10(2) Crosswalks at Intersections**

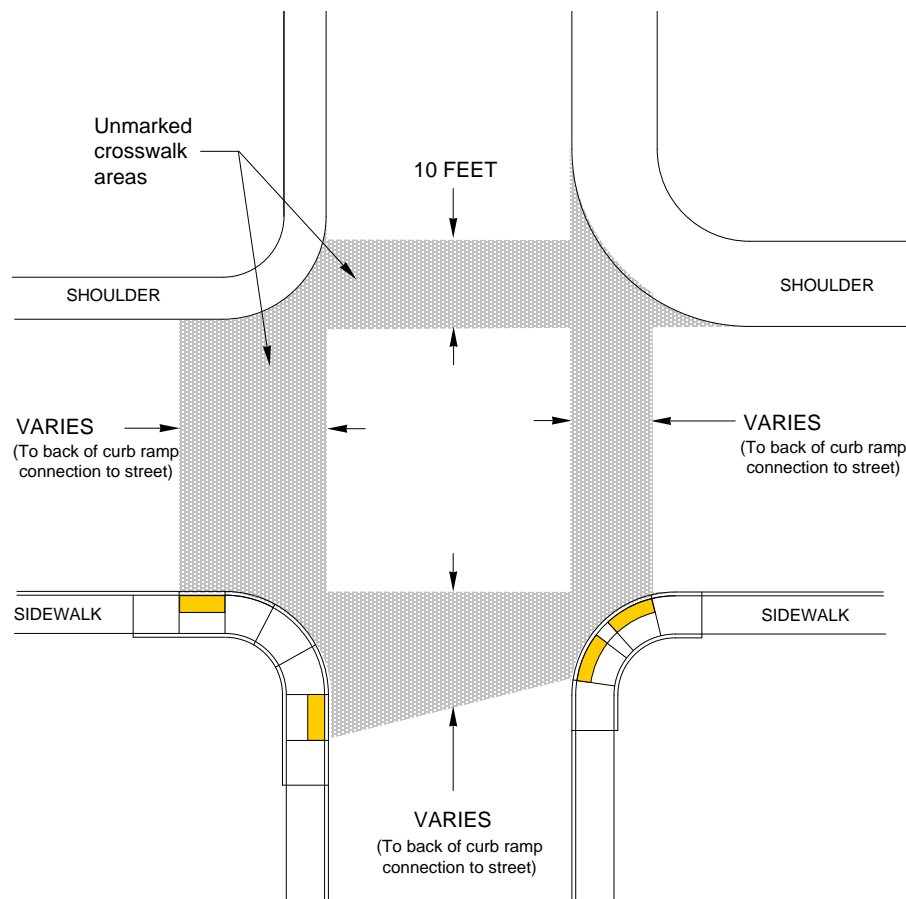
Provide a PAR within marked and unmarked pedestrian crossings. (See 1510.07 for accessibility criteria for PAR.)

Crosswalks are provided on all legs of an intersection, except in rare cases. There are normally three crosswalks at a “T” intersection and four crosswalks at a “four-leg” intersection. For pedestrian route continuity, the minimum number of crosswalks is two at “T” intersections and three at “four-leg” intersections. One example where crosswalks might not be provided on all interaction legs is a diamond interchange with heavy left-turn movements from the off-ramp approach. (See 1510.10(2)(c) for Closed Crossings policy.)

The *Traffic Manual* provides recommendations for determining pedestrian markings based on lane configuration, vehicular traffic volume, and speed. However, coordinate with the region Traffic Engineer early on with any existing or proposed crosswalks. The Traffic Engineer makes the final determination on appropriate signing and delineation.

**1510.10(2)(a) Unmarked Crossings**

Legal crosswalks exist at all intersections, whether marked or not, regardless of the number of legs at the intersection. An unmarked crosswalk (see Exhibit 1510-15) is the portion of the roadway behind a prolongation of the curb or edge of the through traffic lane and a prolongation of the farthest sidewalk connection or, in the event there are no sidewalks, between the edge of the through traffic lane and a line 10 feet from there (RCW 46.04.160).



**Unmarked Crosswalks**  
Exhibit 1510-15



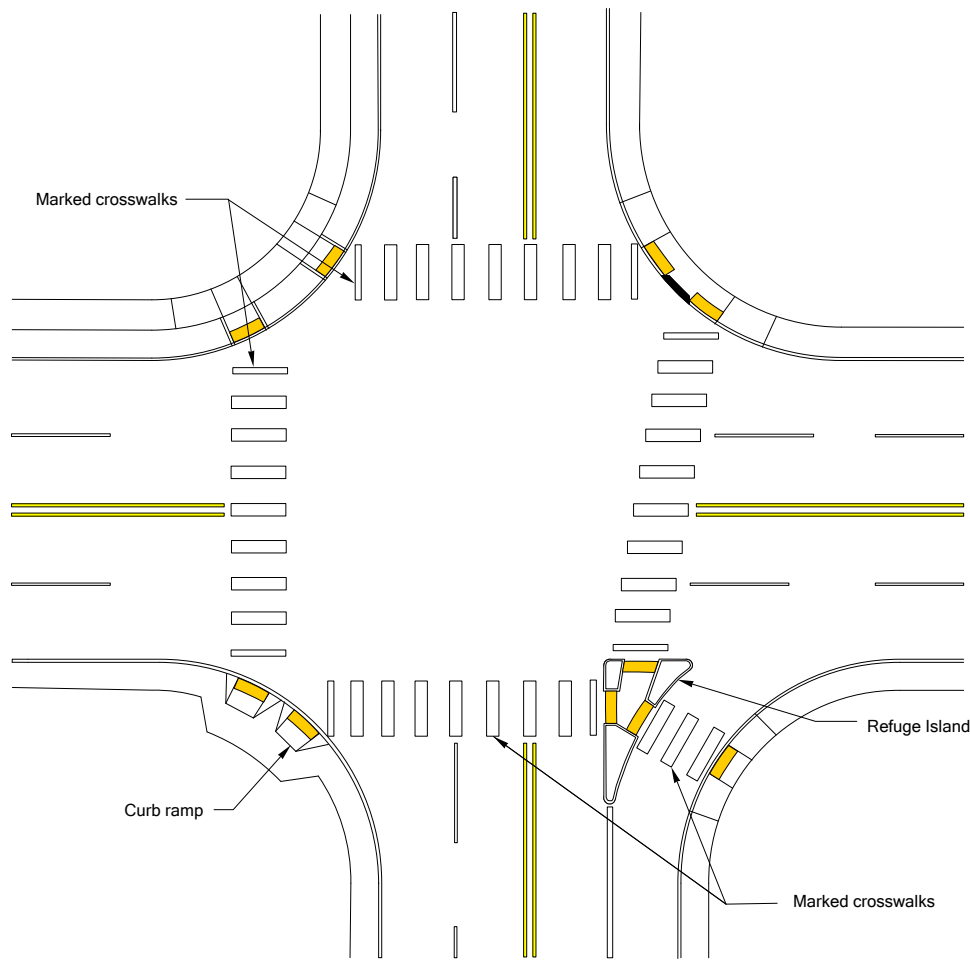
### 1510.10(2)(b) Marked Crossings

Marked crosswalks are used at intersections or midblock crossings. They should not be used indiscriminately, but considered based on a thorough evaluation of site conditions. Maintenance agreements and [RCW 47.24.020](#) provide jurisdictional authority for decisions to mark crosswalks based on a population threshold of 27,500 and should be consulted prior to a decision to mark a crosswalk. Consult region Traffic Offices for “best practices” for marking crosswalks based on intersection type. The [MUTCD](#), the [AASHTO Guide for the Planning, Design, and Operation of Pedestrian Facilities](#), and the [NACTO Urban Street Design Guide](#) are all good resources to use when evaluating locations for marked crosswalks.

The desirable width for a marked crosswalk is 10 feet (6 feet minimum, with justification). The preferred type of marked crosswalk is a longitudinal pattern known as a Ladder Bar, which is shown in the [Standard Plans](#) and [Exhibit 1510-16](#). Stop and yield line dimensions and placement must conform to the [MUTCD](#) and are shown in the [Standard Plans](#).

Some decorative crosswalk materials (such as colored pavement or bricks) may cause confusion for visually impaired pedestrians and can create discomfort for wheelchair users. Supplement decorative crosswalks with pavement markings to enhance visibility and delineate the crosswalk. Refer to the [MUTCD](#) and the Local Agency Crosswalk Options website:

🔗 [www.wsdot.wa.gov/design/standards/plansheet/pm-2.htm](http://www.wsdot.wa.gov/design/standards/plansheet/pm-2.htm)



**Marked Pedestrian Crossing**  
*Exhibit 1510-16*

### 1510.10(2)(c) Closed Crossings

Pedestrian crossings shall only be closed for documented potential or observed crash concerns or for essential signal operations. If a crossing has been previously closed as indicated by existing signing and ADA facilities are being evaluated, provide an appropriate treatment that is detectable by people with vision difficulties who navigate with a cane, such as directional pedestrian curbing and removal of ramps at these closed crossing. The region Traffic Engineer is the approval authority for the closing of crossings.

**Vacant**

*Exhibit 1510-17*

### 1510.10(3) Midblock Crosswalks

On roadways with pedestrian crossing traffic caused by nearby pedestrian generators, a midblock crossing may be appropriate. (See [1510.10\(2\)](#) for crosswalk criteria and the *Traffic Manual* for marked crosswalk recommendations at unsignalized intersections.) The approval authority is the Traffic Engineer.

Engineering judgment of conditions that might increase the value of a midblock crossing includes the following:

- High pedestrian crossing volume present with long block spacing.
- Evidence of pedestrian-vehicular midblock conflicts (site observations, law enforcement reporting, and city traffic engineers).
- Proposed crossing with a realistic opportunity to channel multiple pedestrian crossings to a single location.
- Sight lines that enable sufficient eye contact between motorists and pedestrians.
- Community commitment for a successful outcome.
- Ability to mitigate risks associated with the location using proven countermeasures such as, but not limited to, refuge islands, rectangular rapid flashing beacons, and/or pedestrian hybrid beacons.
- Modal interchange points where high volumes crossing pedestrians occur (e.g., transit stop to apartment complex).

To meet the accessibility criteria, the PAR in the crosswalk may have a cross slope that matches the grade of the roadway. An example of a midblock crossing is shown in [Exhibit 1510-18](#). (See [Chapter 530](#) for further information on pedestrian access and paths on limited access facilities.)

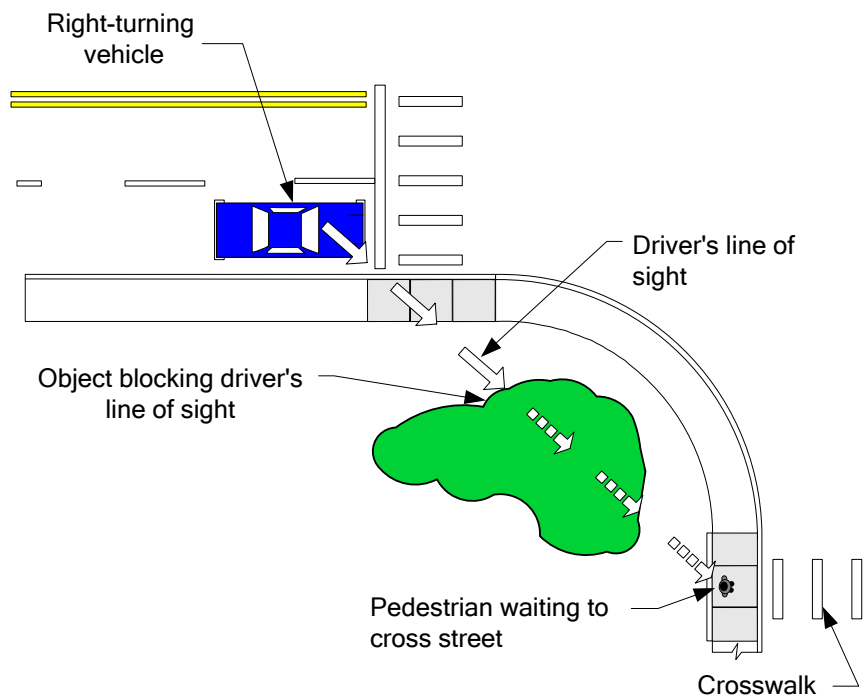
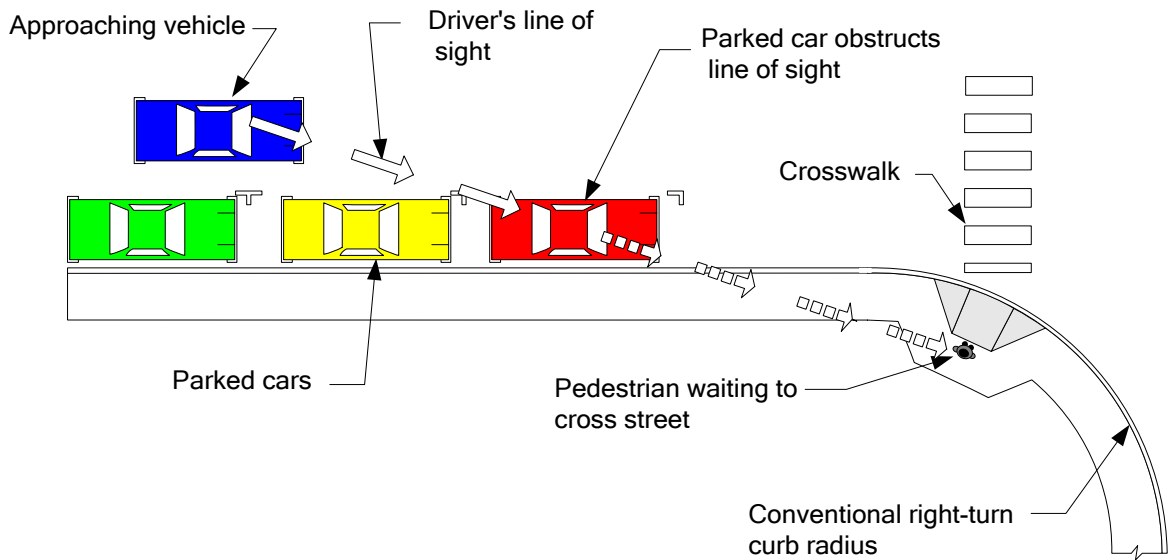




**Midblock Pedestrian Crossing**  
*Exhibit 1510-18*

#### **1510.10(4) Sight Distance at Crosswalks**

When locating crosswalks at intersections, it is important to evaluate the sight lines between pedestrians and motorists. Shrubbery, signs, parked cars, and other roadside elements can block motorists' and pedestrians' views of one another. [Exhibit 1510-19](#) illustrates these sight distance concerns.

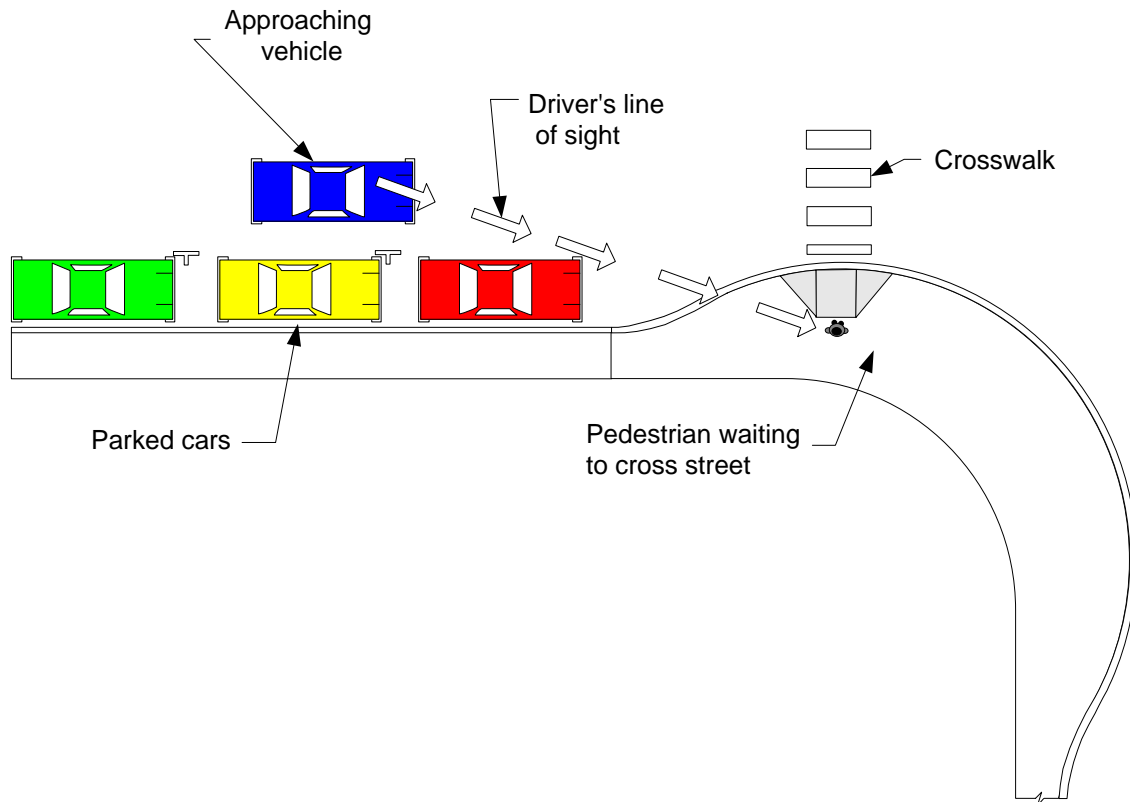


**Obstructed Line of Sight at Intersection**  
*Exhibit 1510-19*

**1510.10(5) Curb Extensions**

Curb extensions are traffic calming measures that may improve sight distance and reduce pedestrian crossing times, which limits pedestrian exposure. Installing a curb extension can help reduce the sight distance problem with parked cars that limit driver/pedestrian visibility. Curb extensions may allow for better curb ramp design as well as provide more space for pedestrians. *Note:* Curb extensions are not an option on streets with high-speed traffic or without on-street parking because drivers would be confronted with sudden changes in roadway width. Extend the curb no farther than the width of the parking lane. (See Chapters 1230, and 1520 for shoulder/bike lane width guidance.) Design the approach nose to ensure adequate setback of

vehicles to provide visibility of pedestrians. At intersections with traffic signals, the curb extensions can be used to reduce pedestrian signal timing. Examples of sidewalk curb extensions are shown in Exhibits 1510-20 and 1510-21.



**Improved Line of Sight at Intersection**  
Exhibit 1510-20



**Curb Extension Examples**  
Exhibit 1510-21

The right-turn path of the design vehicle is a critical element in determining the size and shape of the curb extension. Sidewalk curb extensions tend to restrict the width of the roadway and

can make right turns difficult for large trucks. Ensure the geometry of the curb extension is compatible with the turn path for the design vehicle selected.

Avoid interrupting bicycle traffic with curb extensions.

Do not use curb extensions on state highways when:

- The design vehicle (see [Chapter 1300](#)) encroaches on curbs or opposing lanes, and other solutions will not improve the circumstances.
- On-street parking is not provided/allowed.
- The posted speed is above 35 mph.

Site features such as landscaping, cabinets, poles, benches, planters, bollards, newspaper stands, and sandwich boards should be selected and placed so they do not obstruct the vision of pedestrians or drivers within curb extension areas, as shown in [Exhibit 1510-21](#). Take into account motorist and pedestrian visibility and Design Clear Zone guidelines (see [Chapter 1600](#)).

### 1510.11 Raised Medians/Traffic Islands

Wide multilane streets are often difficult for pedestrians to cross, particularly when there are insufficient gaps in vehicular traffic because of heavy volumes. Consider raised medians and traffic islands with a pedestrian refuge area (see [Exhibit 1510-22](#)) on roadways with the following conditions:

- Two-way arterial with intermediate to high speeds (greater than 35 mph), moderate to high average daily traffic (ADT), and high pedestrian volumes.
- Significant pedestrian crash history.
- Near a school or other community center.
- Crossing distance exceeds 30 feet.
- Complex or irregularly shaped intersections.

A traffic island used for channelized right-turn slip lanes can provide a pedestrian refuge, but the slip lane may promote faster turning speeds. Minimize the turning radius of the slip lane to keep speeds as low as feasible. To reduce conflicts, keep the slip lane as narrow as practicable and design a crosswalk alignment that is at a right angle to the face of curb. (See [Chapters 1310](#) for turn lanes, [1360](#) for interchange ramps, and [1320](#) for pedestrian accommodations in roundabouts.)

The PAR through a raised median or traffic island can be either raised with curb ramps or a cut-through type (see [Exhibit 1510-22](#)). Curb ramps in medians and islands can add difficulty to the crossing for some users. The curbed edges of cut-throughs can be useful cues to the visually impaired in determining the direction of a crossing, especially on an angled route through a median or island.

#### 1510.11(1) Accessibility Criteria for Raised Medians and Traffic Islands

There are many design considerations when deciding whether to ramp up to the median or island grade or create a cut-through median or island matching the roadway grade. These considerations may include the profile grade and cross slope of the road, drainage patterns, and the length or width of the median or island.

The following accessibility criteria apply:

- Each raised median or traffic island shall contain a PAR connecting to each crosswalk (see [1510.07](#)).

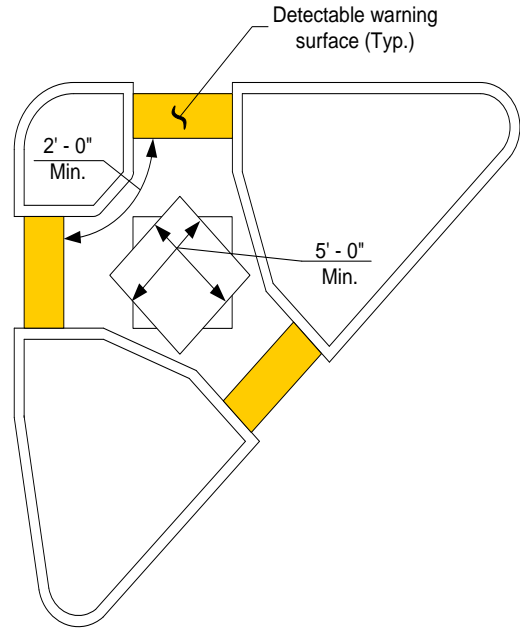
- A passing space shall be provided that is at least 5 feet wide for a distance of at least 5 feet for each PAR in a raised median or on a traffic island (see [Exhibit 1510-22](#)).

*Note:* It is recommended that cut-throughs be designed to have a minimum width of 5 feet to ensure a passing space is provided.

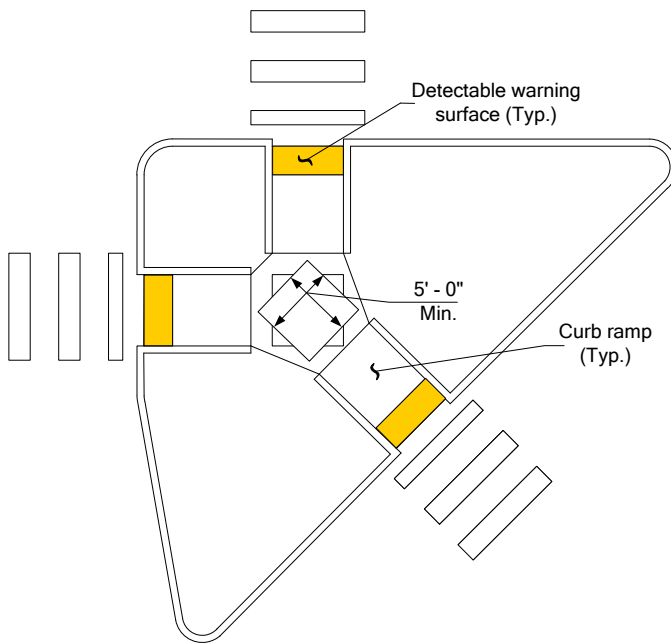
- Medians and pedestrian refuge islands shall be 6 feet minimum in length in the direction of pedestrian travel.
- Detectable warning surfaces are to be separated by 2 feet minimum length in the direction of pedestrian travel.
- Detectable warning surfaces are located at each curb ramp or roadway entrance of a PAR through a raised median or traffic island. The detectable warning surface shall be located at the back of the curb (see [Exhibit 1510-22](#)).
- PARs of shared-use paths that go through raised medians or traffic islands shall be the same width as the shared-use path (see [Chapter 1515](#)).



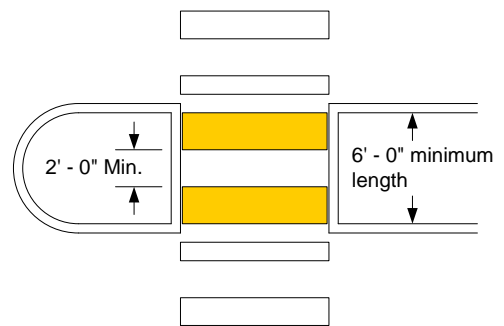
Island Cut-Through



Island Cut-Through



Raised Traffic Island With Curb Ramps



Median Island Cut-Through (full width shown)  
(See 1510.11(1) for minimum accessibility criteria.)

See the [Standard Plans](#) for details.

**Raised Islands With Curb Ramps and Pedestrian Cut-Throughs**  
*Exhibit 1510-22*

## 1510.12 Pedestrian Pushbuttons

Pedestrian pushbuttons are an operating control with their own accessibility requirements. All pedestrian pushbuttons, regardless of the type of system they are part of, require a level clear space located so that users of all types can reach the button to actuate the associated system.

### 1510.12(1) **Accessibility Criteria for All Pedestrian Pushbuttons (including APS)**

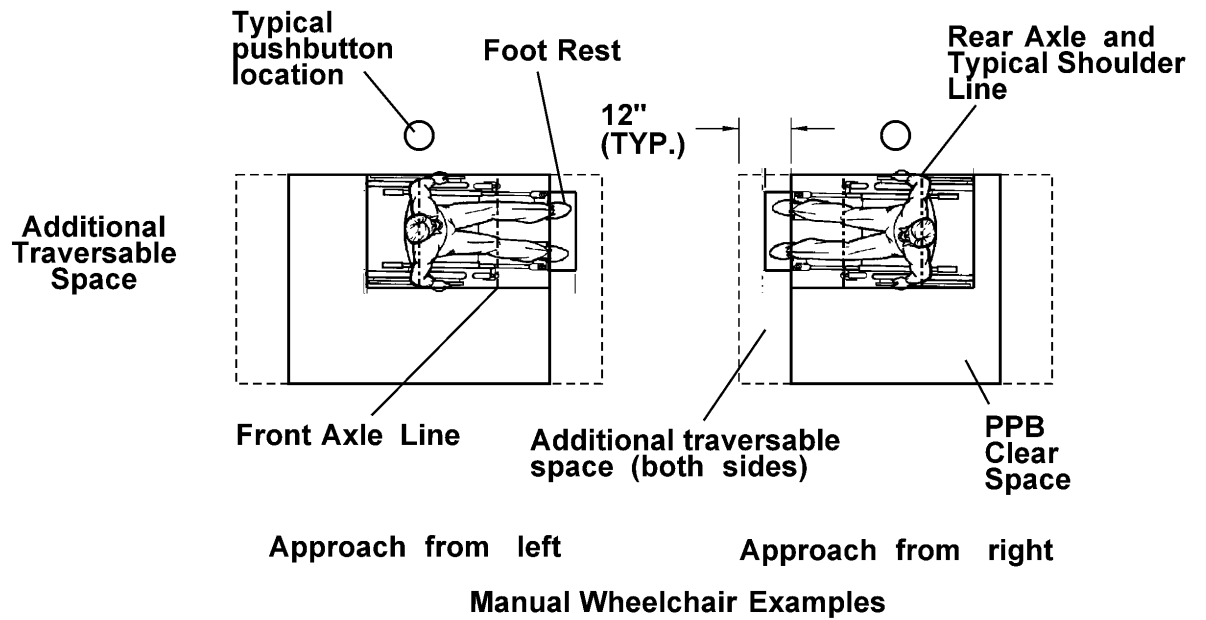
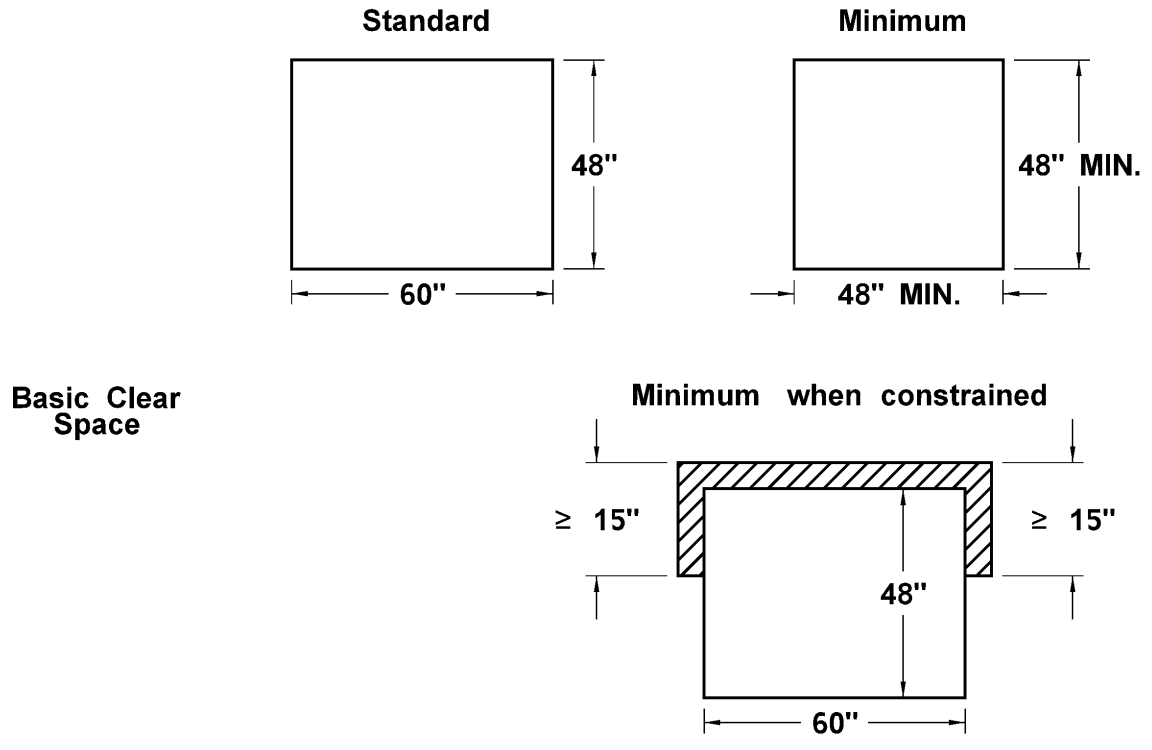
#### 1510.12(1)(a) **Location Requirements**

- See [1330.04\(4\)](#) for pushbutton location requirements. These location requirements limit the potential locations for the pedestrian pushbutton clear space.

#### 1510.12(1)(b) **Clear Space Requirements**

- Grade: 2% maximum running and cross slopes.
- Clear space dimensions:
  - a. Standard: 48 inches in width by 60 inches in length, with the pushbutton located along one of the long sides of the clear space.
  - b. Minimum: 48 inches minimum width by 48 inches minimum length. Although the ADA minimum required clear space for an operational control is 30 inches by 48 inches, the narrow dimension is increased to 48 inches to allow for maneuvering, similar to a curb ramp landing (see [Exhibit 1510-23](#)). If the clear space is constrained on three sides, such that the clear space is set back 15 inches or more from the PAR, then the clear space shall be 48 inches minimum width by 60 inches minimum length, to allow for maneuvering within the constrained space. (see [Exhibit 1510-23](#)).
- Additional unobstructed or traversable space of 12 inches on either end of the clear space should be provided if possible, to allow for protruding equipment such as foot rests to extend beyond the clear space. This helps mobility assistance device users get their shoulder line closer to the pushbutton (see [Exhibit 1510-23](#)).
- Clear space is allowed to overlap other PAR elements (i.e., sidewalk/curb ramp landing) (see [Exhibits 1510-24a and 1510-24b](#)).
- Clear space must be connected to the crosswalk served by the pedestrian pushbutton with a PAR.

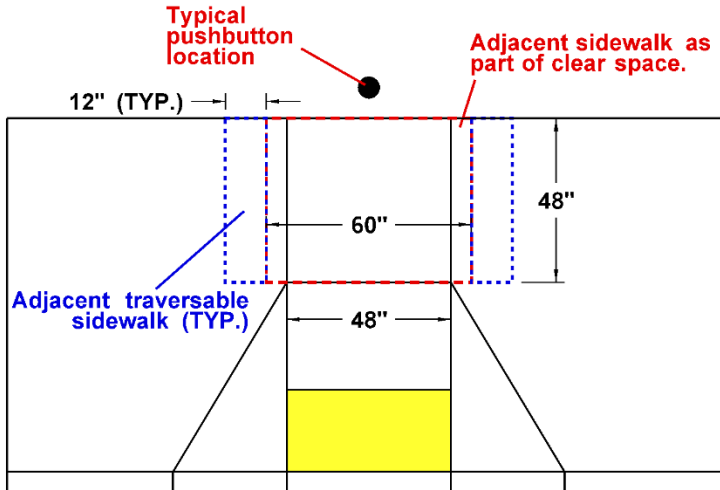




**Clear Space for Pedestrian Pushbutton**  
*Exhibit 1510-23*



Perpendicular Ramp Option:  
Use Adjacent Level Sidewalk  
(Not to scale)

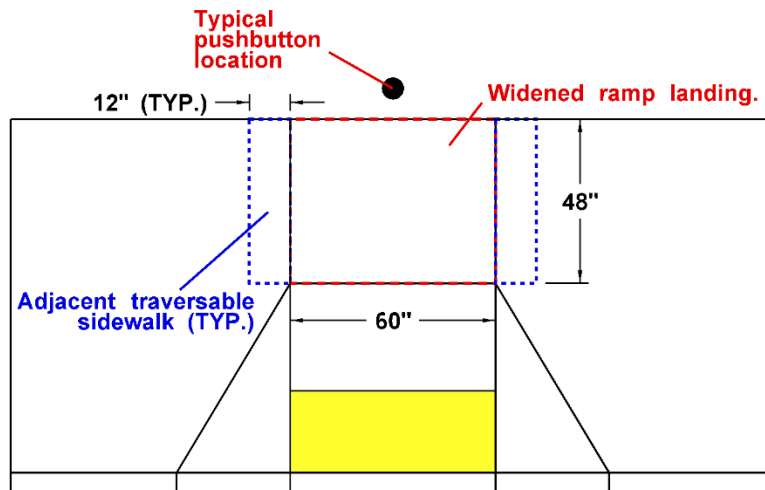


Crosswalk Marking



Crosswalk Direction

Perpendicular Ramp Option:  
Widen Ramp and Landing  
(Not to scale)

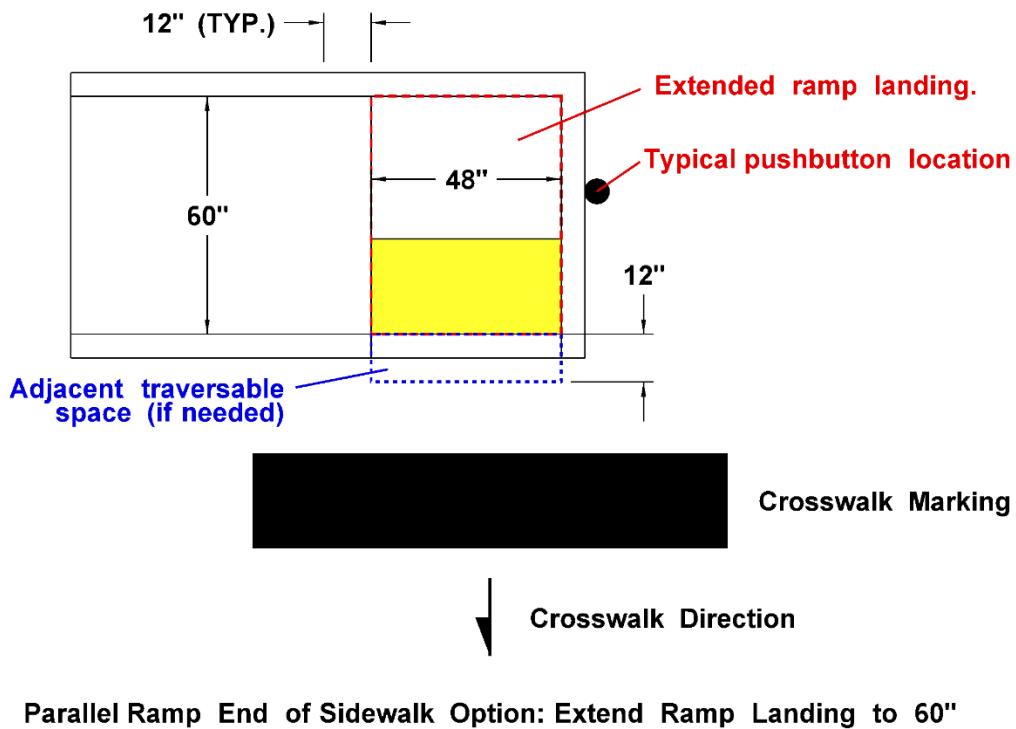
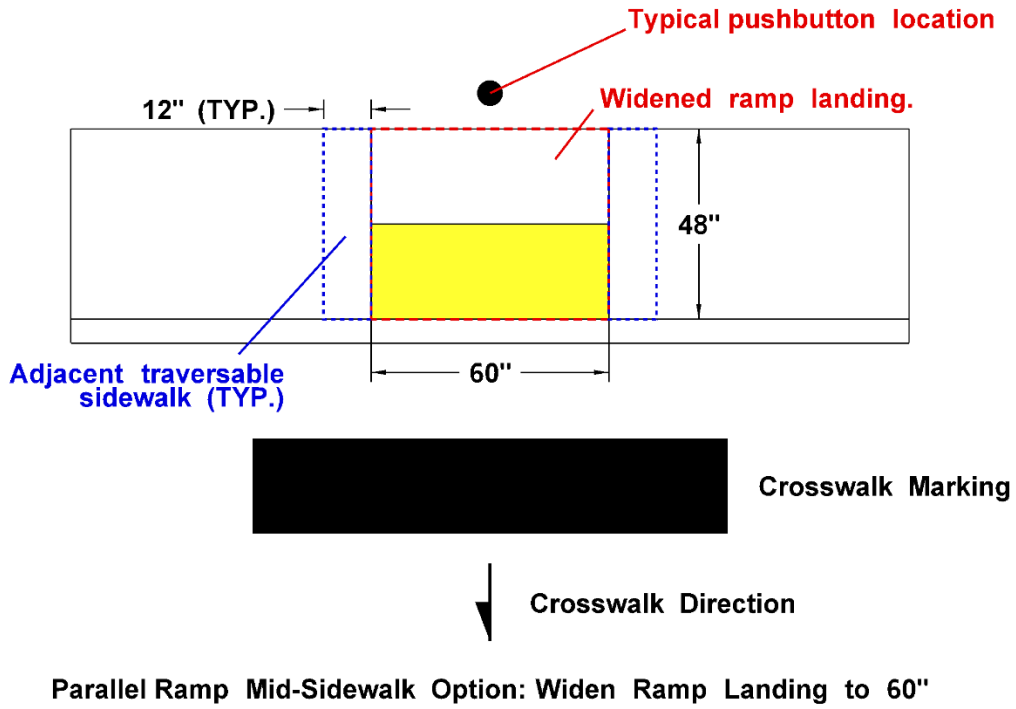


Crosswalk Marking



Crosswalk Direction

Perpendicular Ramp Concurrent Clear Space Examples  
Exhibit 1510-24a



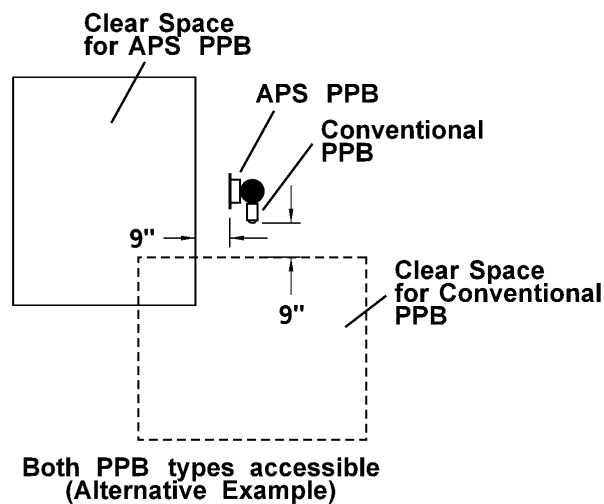
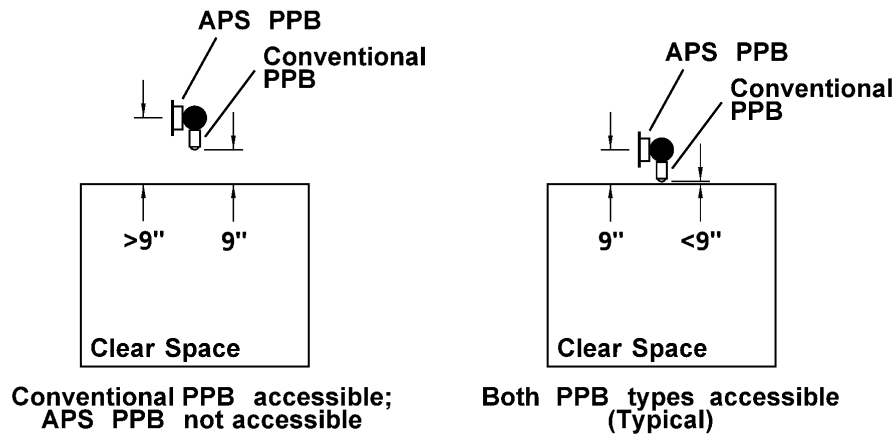
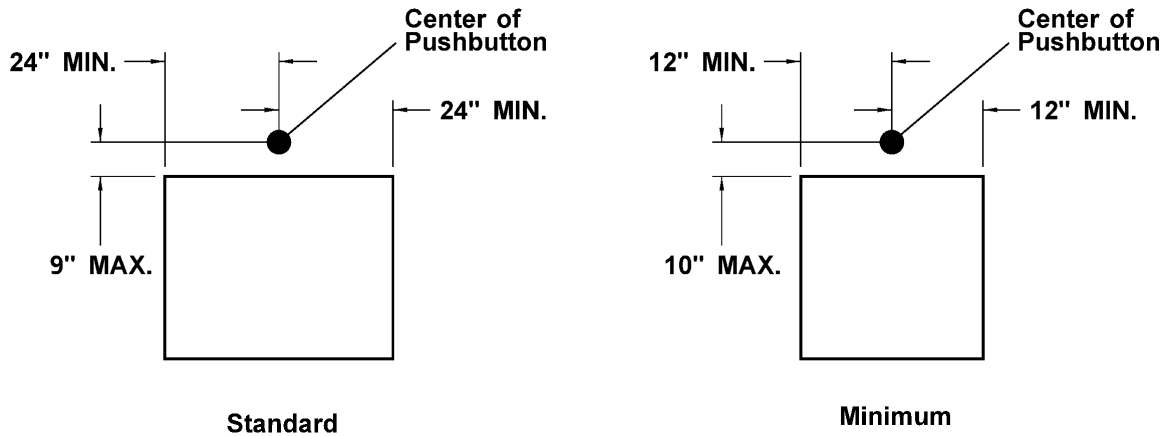
**Parallel Ramp Concurrent Clear Space Examples**

*Exhibit 1510-24b*

### 1510.12(1)(c) Reach Range Requirements

Pushbuttons are in locations considered unobstructed, and follow the allowable unobstructed reach distance requirements of the ADA accessibility requirements. This manual designs clear space for pushbuttons based on a parallel approach, due to difficulties in both accessibility and design when attempting to accommodate a forward reach.

- The provided clear space must be within reach range of the pedestrian pushbutton.
- The reach range is 10 inches maximum, as measured from the edge of the clear space to the center of the physical pushbutton (not just the housing).
- For new construction, the center of the physical pushbutton shall be no more than 9 inches from the edge of the clear space. It is preferable to locate the pushbutton as close to the edge of the clear space as possible.
- Different types of pushbuttons (front mount H-frame type versus side mount Accessible Pedestrian Signal type) will have different reach ranges on the same pole. Generally, designing for a side mount pushbutton will result in a front mount pushbutton also being within the required reach range. This is generally not true the other way around. (see [Exhibit 1510-25](#))
- The center of the physical pushbutton shall be 42 inches above the surface of the clear space. Existing installations may remain if they are within a range of 36 inches minimum to 48 inches maximum above the surface of the clear space.
- The pushbutton shall be a minimum of 12 inches in from both ends of the clear space, and should be at least 24 inches in from both ends of the clear space. Ideally, the pushbutton should be centered along one side of the clear space. If the clear space is rectangular, the pushbutton shall be located along one of the long sides of the clear space.



NOTE: See Exhibits 1330-14a and 1330-14b for pole setback limits

**Reach Range for Pedestrian Pushbuttons**  
*Exhibit 1510-25*

### 1510.12(2) Accessible Pedestrian Signals (APS)

APS are only installed where there is a pedestrian traffic signal display (walking person / hand). APS are not installed as part of crosswalk flashing beacon systems. See [Chapter 1330](#) for additional information on APS equipment.

### 1510.13 At-Grade Railroad Crossings

The design of pedestrian facilities that cross railroad tracks (see [Exhibit 1510-26](#)) often presents challenges due to the conflicting needs of pedestrians and trains. In particular, the flangeway gap for trains to traverse a crossing surface may create a significant obstacle for a person who uses a wheelchair, crutches, or walking aids for mobility. Whenever practicable, align pedestrian crossings perpendicular to the tracks in order to minimize potential problems related to flangeway gaps. Crossing surfaces may be constructed of timber planking, rubberized materials, or concrete. Concrete materials generally provide the smoothest and most durable crossing surfaces. When detectable warning surfaces are used at railroad crossings, place them according to the [MUTCD](#) stop line placement criteria.



Undesirable



Recommended

#### Pedestrian Railroad Crossings

##### *Exhibit 1510-26*

There are a number of railroad crossing warning devices (see [Exhibit 1510-27](#)) intended specifically for pedestrian facilities (see the [MUTCD](#)). When selecting warning devices, factors such as train and pedestrian volumes, train speeds, available sight distance, number of tracks, and other site-specific characteristics should be taken into account. Coordinate with the HQ Design Office Railroad Liaison early in the design process so that all relevant factors are considered and an agreement may be reached regarding the design of warning devices and crossing surfaces.



**Pedestrian Railroad Warning Device**  
*Exhibit 1510-27*

Except for crossings located within the limits of first-class cities,\* the Washington Utilities and Transportation Commission (WUTC) approves proposals for any new railroad at-grade crossings or changes to warning devices or geometry at existing crossings. Additionally, any project that requires the railroad to perform work such as installation of warning devices or crossing surfaces must obtain a railroad construction and maintenance agreement. Contact the HQ Design Office Railroad Liaison to coordinate with both the WUTC and the railroad company.

\*[RCW 35.22.010](#): A first class city is a city with a population of ten thousand or more at the time of its organization or reorganization that has a charter adopted under Article XI, section 10, of the state Constitution.

*Note:* There are very few first-class cities in the state of Washington. Verify with the HQ Design Office Railroad Liaison.

## 1510.14 Pedestrian Grade Separations (Structures)

On the approach to a bridge that has a raised sidewalk, provide a ramp that transitions to the sidewalk from the paved shoulder. A ramp that transitions from a paved shoulder to a sidewalk on a bridge is to have a slope of 5% maximum and be constructed of asphalt or cement concrete. In addition to aiding pedestrian access, the ramp also serves as a roadside safety feature to mitigate the raised blunt end of the concrete sidewalk. If a PCP (such as a raised sidewalk or shared-use path) is located near the bridge, consider eliminating the gap between the bridge sidewalk and the PCP by extending the bridge sidewalk to match into the nearby PCP.

At underpasses where pedestrians are allowed, it is desirable to provide sidewalks and to maintain the full shoulder width. When bridge columns are placed on either side of the roadway, it is preferred to place the walkway between the roadway and the columns for pedestrian visibility and security. Provide adequate illumination and drainage for pedestrian safety and comfort.

In cases where there is a pedestrian crash history, and the roadway cannot be redesigned to accommodate pedestrians at grade, planners should consider providing a grade-separated pedestrian structure (see [Exhibits 1510-28](#) and [1510-29](#)). When considering a grade-separated pedestrian structure, determine whether the conditions that require the crossing are permanent. If there is likelihood that pedestrians will not use a grade separation, consider less-costly solutions.

Locate the grade-separated crossing where pedestrians are most likely to cross the roadway. A crossing might not be used if the pedestrian is required to deviate significantly from a more direct route.

It is sometimes necessary to install fencing or other physical barriers to channel the pedestrians to the structure and reduce the possibility of undesired at-grade crossings. **Note:** The HQ Bridge and Structures Office is responsible for the design of pedestrian structures.

Consider a grade-separated crossing where:

- There is moderate to high pedestrian demand to cross a freeway or expressway.
- There are large numbers of young children, particularly on school routes, who regularly cross high-speed or high-volume roadways.
- The traffic conflicts that would be encountered by pedestrians are considered unacceptable (such as on wide streets with high pedestrian volumes combined with high-speed traffic).
- There are documented crashes or close calls involving pedestrians and vehicles
- One or more of the conditions stated above exists in conjunction with a well-defined pedestrian origin and destination (such as a residential neighborhood across a busy street from a school).

### **1510.14(1) Pedestrian Bridges**

Pedestrian grade-separation bridges (see [Exhibit 1510-28](#)) are more effective when the roadway is below the natural ground line, as in a cut section. Elevated grade separations in cut sections, where pedestrians climb stairs or use long approach ramps, tend to be underused. Pedestrian bridges need adequate right of way to accommodate accessible ramp approaches leading up to and off of the structure. The bridge structure must comply with ADA requirements and meet the accessibility criteria for either a pedestrian circulation path (if the grade is 5% or less) or an access ramp (if the grade is greater than 5% but less than or equal to 8.3%), and must include a pedestrian access route. (See [1510.06](#) and [1510.07](#) for PCP and PAR accessibility criteria; see [1510.15\(2\)](#) for access ramp accessibility criteria.)

For the minimum vertical clearance from the bottom of the pedestrian structure to the roadway beneath, see [Chapter 720](#). The height of the structure can affect the length of the pedestrian ramp approaches to the structure. When access ramps are not feasible, provide both elevators and stairways.

Provide railings on pedestrian bridges. Protective screening is sometimes desirable to deter pedestrians from throwing objects from an overhead pedestrian structure (see [Chapter 720](#)).

The minimum clear width for pedestrian bridges is 8 feet. Consider a clear width of 14 feet where a pedestrian bridge is enclosed or shared with bicyclists, or equestrians, or if maintenance or emergency vehicles will need to access.





**Pedestrian Bridges**  
*Exhibit 1510-28*

### 1510.14(2) Pedestrian Tunnels

Tunnels are an effective method of providing crossings for roadways located in embankment sections. Well-designed tunnels can be a desirable crossing for pedestrians. When feasible, design the tunnel with a nearly level profile to provide an unobstructed line of sight from portal to portal (see [Exhibit 1510-29](#)). People may be reluctant to enter a tunnel with a depressed profile because they are unable to see whether the tunnel is occupied. Law enforcement also has difficulty patrolling depressed profile tunnels.

Provide vandal-resistant daytime and nighttime illumination within the pedestrian tunnel. Installing gloss-finished tile walls and ceilings can enhance light levels within the tunnel. The minimum overhead clearance for a pedestrian tunnel is 10 feet. The minimum width for a pedestrian tunnel is 12 feet. Consider a tunnel width between 14 and 18 feet depending on usage and the length of the tunnel.



**Pedestrian Tunnel**  
*Exhibit 1510-29*

Pedestrian tunnels need adequate right of way to accommodate accessible approaches leading to the tunnel structure. The tunnel structure must comply with ADA requirements and meet the accessibility criteria for either a pedestrian circulation path (if the grade is less than or equal to 5%) or an access ramp (if the grade is greater than 5% and less than or equal to 8.3%), and must include a pedestrian access route. (See [1510.06](#) and [1510.07](#) for PCP and PAR accessibility criteria; see [1510.15\(2\)](#) for access ramp accessibility criteria.)



## 1510.15 Other Pedestrian Facilities

### 1510.15(1) Transit Stops and School Bus Stops

The location of transit stops is an important element in providing appropriate pedestrian facilities. (Coordinate with the local transit provider.) Newly constructed transit stops must conform to ADA requirements. Design newly constructed transit stops so that they are accessible from the sidewalk or paved shoulder. A transit stop on one side of a street usually has a counterpart on the opposite side because transit routes normally function in both directions on the same roadway. Provide adequate crossing facilities for pedestrians.

When locating a transit stop (see [Traffic Manual 7.9](#)), consider transit ridership and land use demand for the stop. Also, take into account compatibility with the following roadway/traffic characteristics:

- ADT
- Traffic speed
- Crossing distance
- Crash history
- Sight distance
- Connectivity to a pedestrian access route
- Traffic generator density

If any of these suggests an undesirable location for a pedestrian crossing, consider a controlled crossing or another location for the transit stop. (See [Chapter 530](#) for further information on bus stops on limited access facilities.)

When analyzing a transit stop location with high pedestrian crash frequency, take into account the presence of nearby transit stops and opportunities for pedestrians to cross the street in a reasonably safe manner. At-grade midblock pedestrian crossings may be effective at transit stop locations on roadways with lower vehicular volumes. Pedestrian grade separations are appropriate at midblock locations when vehicular traffic volumes prohibit pedestrian crossings at grade. (See the [Traffic Manual](#) for recommendations for marked crosswalks at unsignalized intersections.)

School bus stops are typically adjacent to sidewalks in urban areas and along shoulders in rural areas. Determine the number of children using the stop and provide a waiting area that allows the children to wait for the bus. Coordinate with the local school district. Because of their smaller size, children might be difficult for motorists to see at crossings or stops. Determine whether utility poles, vegetation, and other roadside features interfere with motorists' ability to see the children. When necessary, remove or relocate the obstructions or move the bus stop. Parked vehicles can also block visibility, and parking prohibitions might be advisable near the bus stop. Coordinate transit and school bus stop locations with the region Traffic Office.

### 1510.15(2) Access Ramps Serving Transit Stops, Park & Ride Lots, Rest Areas, Buildings, and Other Facilities

An access ramp (see [Exhibit 1510-30](#)) provides an accessible pedestrian route from a pedestrian circulation path to a facility such as a transit stop, park & ride lot, rest area, pedestrian overcrossing/undercrossing structure, or building. When the running slope is 5% or less, it can be designed as a pedestrian circulation path that includes a pedestrian access route. When the running slope is greater than 5% to a maximum of 8.3%, it must be designed as an access ramp. (See [1510.06](#) and [1510.07](#) for PCP and PAR accessibility criteria; see [1510.15\(2\)\(a\)](#) for access ramp accessibility criteria.)

**1510.15(2)(a) Accessibility Criteria for Access Ramps**

Access ramps are composed of one or more ramp segments interconnected by level landings. Unless superseded by the following specific accessibility requirements for access ramps, the accessibility requirements for pedestrian access routes also apply:

- Ramp segments shall have a maximum running slope of 8.3%.
- The cross slope of ramp segments shall be 2% maximum.
- The minimum clear width of ramps is 4 feet; however, it is desirable to match the width of the connecting pedestrian facility.
- The rise for any ramp segment shall be 30 inches maximum.
- A level landing (2% maximum running and cross slopes) shall be provided at the top and bottom of each access ramp segment.
- An access ramp landing's clear width shall be at least as wide as the widest ramp segment leading to the landing.
- An access ramp landing's length shall be 5 feet minimum.
- Access ramps that change direction between ramp segments at landings shall have a level landing 5 feet minimum width by 5 feet minimum length.
- All access ramp segments with a rise greater than 6 inches shall have ADA-compliant handrails (see [1510.15\(3\)](#) for handrail accessibility criteria).

Provide edge protection complying with one of the two following options on each side of access ramp segments:

- The surface of the ramp segment and landing shall extend 12 inches minimum beyond the inside face of the handrail.
- A curb or barrier shall be provided that does not allow the passage of a 4-inch-diameter sphere, where any portion of the sphere is within 4 inches of the ramp/landing surface.



**Access Ramp With Accessible Handrails**  
*Exhibit 1510-30*

### **1510.15(3) Railings and Handrails for Pedestrian Facilities**

Accessible handrails are required on stairs and also on access ramps that have a rise greater than 6 inches (see [1510.15\(2\)\(a\)](#) for access ramp accessibility criteria). If the height of a drop-off (typically greater than 30 inches) adjacent to a pedestrian facility necessitates the need to protect pedestrians from falls, then a more robust railing system designed for fall protection should be used. If the drop-off is adjacent to either a stairway or an access ramp with a rise greater than 6 inches, then a combined railing system that meets the requirements for both accessibility and fall protection must be used.

#### **1510.15(3)(a) Fall Protection Railing**

Railing designed for fall protection alone is typically placed adjacent to pedestrian facilities other than stairs or access ramps to prevent pedestrians or bicyclists from falls. The minimum railing height for pedestrian fall protection is 42 inches. For facilities where bicycle traffic is anticipated, such as on a grade-separation structure on a shared-use facility (see [Chapter 1515](#)), the minimum railing height for bicyclist fall protection is 54 inches.

#### **1510.15(3)(b) Accessible Fall Protection Railing**

When fall protection is needed adjacent to stairs or an access ramp that has a rise greater than 6 inches, then a combined railing system that meets both the accessibility criteria for handrail outlined in [1510.15\(3\)\(d\)](#) and the requirements for fall protection must be used. The minimum railing height for pedestrian fall protection is 42 inches. For facilities where bicycle traffic is anticipated, such as on the approach to a grade-separation structure on a shared-use facility (see [Chapter 1515](#)), the minimum railing height for bicyclist fall protection is 54 inches.

#### **1510.15(3)(c) Accessible Handrail**

Accessible handrail meeting the accessibility criteria listed in [1510.15\(3\)\(d\)](#) that is not designed to provide fall protection is to be used adjacent to stairs or access ramps that have a rise greater than 6 inches at locations where robust fall protection is not needed.

#### **1510.15(3)(d) Accessibility Criteria for Handrail**

The following accessibility criteria apply to all handrail installations provided at stairs and access ramps that have a rise greater than 6 inches.

##### **1. Height**

- The top of handrail gripping surfaces shall be 34 inches minimum and 38 inches maximum vertically above walking surfaces, stair nosings, and ramp surfaces.
- The mounting height of the handrail shall also be at a consistent height.

##### **2. Gripping Surface**

- Clearance between handrail gripping surfaces and adjacent surfaces shall be 1½ inches minimum.
- Handrail gripping surfaces shall be continuous along their length and shall not be obstructed along their tops or sides.
- The bottoms of handrail gripping surfaces shall not be obstructed for more than 20% of their length.
- Where provided, horizontal projections shall be located 1½ inches minimum below the bottom of the handrail gripping surface.

- Handrail gripping surfaces with a circular cross section shall have an outside diameter between 1¼ inches minimum and 2 inches maximum.
- Handrail gripping surfaces with a noncircular cross section shall have a perimeter dimension between 4 inches minimum and 6¼ inches maximum, and a cross section dimension of 2¼ inches maximum.
- Handrail gripping surfaces and the surfaces adjacent to them shall be free of sharp or abrasive elements and shall have rounded edges.
- Handrails shall not rotate in their fittings.

### 3. Placement and Continuity

- Handrails shall be provided on both sides of access ramps and stairs.
- Handrails shall be continuous within the full length of each access ramp run or stair flight.
- Inside handrails on switchback or dogleg access ramps and stairs shall be continuous between runs or flights.

### 4. Extensions

- Access ramp handrails shall extend horizontally above the landing for 12 inches minimum beyond the top and bottom of ramp runs.
- At the top of a stair flight, handrails shall extend horizontally above the landing for 12 inches minimum beginning directly above the first riser nosing.
- At the bottom of a stair flight, handrails shall extend at the slope of the stair flight for a horizontal distance at least equal to one tread depth beyond the last riser nosing.
- Handrail extensions shall return to a wall, guard, or the landing surface, or shall be continuous to the handrail of an adjacent access ramp run or stair flight.

*Exception:* Handrail extensions shall not be required for continuous handrails at the inside turn of switchback or dogleg access ramps or stairs.

## 1510.15(4) Other Pedestrian Facilities, Features, and Elements

This chapter covers the accessibility criteria for the most commonly encountered pedestrian design elements in the public right of way. However, there are ADA requirements that apply to any feature or element for pedestrian use, such as doorways, elevators, stairs, call boxes, and drinking fountains. For accessibility criteria for less commonly encountered pedestrian design elements, consult the applicable federal guidance document(s) listed in [1510.02\(2\)](#).

## 1510.16 Illumination and Signing

In Washington State, the highest number of crashes between vehicles and pedestrians tends to occur during November through February, when there is poor visibility and fewer daylight hours. Illumination of pedestrian crossings and other walkways is an important design consideration because lighting has a major impact on a pedestrian's safety and sense of security. Illumination provided solely for vehicular traffic is not always effective in lighting parallel walkways for pedestrians. Consider pedestrian-level (mounted at a lower level) lighting for PCPs, intersections, and other pedestrian crossing areas with high nighttime pedestrian activity, such as shopping districts, transit stops, schools, community centers, and other major pedestrian generators or areas with a history of pedestrian crashes. (See [Chapter 1040](#) for design guidance on illumination, and [Chapter 1020](#) and the [MUTCD](#) for pedestrian-related signing.)

## 1510.17 Work Zone Pedestrian Accommodation

While Title II of the ADA requires that a public entity maintain its pedestrian facilities in operable working condition, including maintenance of their accessibility features, construction and maintenance activities often temporarily disrupt these facilities. When this occurs, provide access and mobility for pedestrians through and around work zones (see [Exhibit 1510-31](#)). Address this in the temporary traffic control plans if the project occurs in a location accessible to pedestrians. The designer must determine pedestrian needs in the proposed work zone during the public input process and through field visits.

Detailed guidance on work zone pedestrian accommodation can be found in the WSDOT *Field Guide for Accessible Public Rights of Way*, the [MUTCD](#), and [Chapter 1010](#).

Some work zone considerations include:

- Separate pedestrians from conflicts with work zone equipment and operations.
- Separate pedestrians from traffic moving through or around the work zone.
- Provide pedestrians with alternate routes that have accessible and convenient travel paths that duplicate, as closely as feasible, the characteristics of the existing pedestrian facilities.

Provide walkways that are clearly marked and pedestrian barriers that are continuous, rigid, and detectable to vision-impaired persons who navigate with a cane. Also, keep:

- The pedestrian head space clear.
- Walkways free from pedestrian hazards such as holes, debris, and abrupt changes in grade or terrain.
- Access along sidewalks clear of obstructions such as construction traffic control signs.
- A minimum clear width path throughout: 4 feet for pedestrians or 10 feet for pedestrians and bicyclists.

Temporary pedestrian facilities within the work zone must meet accessibility criteria to the maximum extent feasible. (See [1510.06](#) and [1510.07](#) for pedestrian circulation path and pedestrian access route accessibility criteria.)

Consider the use of flaggers if pedestrian generators such as schools are in the work zone vicinity. Consider spotters who are prepared to help pedestrians through the work zone.

Provide for advance public notification of sidewalk closures in the contract special provisions and plans.

Where transit stops are affected or relocated because of work activity, provide an accessible route to temporary transit stops.



Meets ADA requirements



Does not meet ADA requirements

**Work Zones and Pedestrian Facilities**  
*Exhibit 1510-31*

**1510.18 Documentation**

Refer to [Chapter 300](#) for design documentation requirements.



- 1600.01 General
- 1600.02 Clear Zone
- 1600.03 Mitigation Guidance
- 1600.04 Medians
- 1600.05 Other Roadside Safety Features
- 1600.06 Documentation
- 1600.07 References

## 1600.01 General

Roadside safety addresses the area outside the roadway and is an important component of total highway design. There are numerous reasons why a vehicle leaves the roadway, including driver error and behaviors. Regardless of the reason, a roadside design can reduce the severity and subsequent consequences of a roadside encroachment. From a crash reduction and severity perspective, the ideal highway has roadsides and median areas that are relatively flat and unobstructed by objects. It is also recognized that different facilities have different needs and considerations, and these issues are considered in any final design.

It is not possible to provide a clear zone free of objects at all locations and under all circumstances. The engineer faces many tradeoffs in design decision-making, balancing needs of the environment, right of way, and various modes of transportation. The fact that recommended design values related to the installation of guardrail and other mitigative actions are presented in this chapter does not require the WSDOT to modify or upgrade locations to meet current criteria.

Roadside safety may be addressed by projects identified through priority programming, during certain preservation project activities (See [Chapter 1120](#)), or may be considered by projects as part of a safety analysis (See [Chapter 321](#)). Elements such as sideslopes, fixed objects, and water are all features that a vehicle might encounter when it leaves the roadway and become part of such an analysis.

On projects where the need for mitigation is determined, consider the following mitigative measures (in order of priority):

1. Remove
2. Redesign (a fixed object) so it can be traversable (See [Section 1600.03\(2\)](#))
3. Relocate
4. Reduce impact severity (using breakaway features or making it traversable)
5. Shield with a traffic barrier; or
6. Delineate (if the previous options are not appropriate or feasible)

Factors for selecting a mitigative measure include, but may not be limited to:

- Cost (initial and life cycle costs)
- Maintenance needs
- Crash severity potential

Rumble strips can be employed to reduce the potential for lane departure or roadside encroachment in certain contexts (see [Section 1600.05\(1\)](#)). Use traffic barriers when other measures cannot reasonably be accomplished and conditions are appropriate based on an engineering analysis (See [Chapter 1610](#)).

## 1600.02 Clear Zone

A clear roadside border area is a primary consideration when analyzing roadside and median features (as defined in [Section 1600.03](#)). The intent is to provide as much clear, traversable area for a motorist to recover as practicable given the function and context of the roadway and the potential tradeoffs. The Design Clear Zone is used to evaluate the adequacy of the existing clear area and proposed modifications of the roadside. When considering the placement of new objects along the roadside or median, evaluate the potential for impacts and try to select locations with the least likelihood of an impact by an errant motorist.

In situations where the Design Clear Zone is beyond WSDOT right of way, evaluate options on a case-by-case basis. Consider the nature of the objects within the Design Clear Zone, the roadway geometry, traffic volume, and crash history. Coordinate with adjacent property owners when proposed options include any work beyond WSDOT right of way. At a minimum, provide clear zone to the limits of the WSDOT right of way.

Clear zone is measured from the edge of the through traveled way. All projects that alter the relationship between the through lane and the roadside by widening or realignment have altered the existing clear zone, and require an evaluation of objects in the clear zone. Auxiliary lanes longer than 400 feet generally operate the same as a through lane and should be considered through lanes for the purpose of determining Design Clear Zone.

### 1600.02(1) Design Clear Zone along Limited Access State Highways and Other State Highways Outside Incorporated Cities and Towns

Use the Design Clear Zone Inventory form ([Exhibit 1600-3](#)) to identify features to be mitigated and propose actions taken to address those features.

Guidance for establishing the Design Clear Zone for highways outside incorporated cities is provided in [Exhibit 1600-2](#). This guidance also applies to limited access facilities within the city limits. Providing a clear recovery area that is consistent with this guidance does not require any additional documentation. However, there might be situations where it is not practicable to provide these recommended distances. In these situations, document the decision as a Design Analysis as discussed in [Chapter 300](#).

There is flexibility in establishing the Design Clear Zone in urbanized or urbanizing areas where operating speeds are 35 mph or less. To achieve this flexibility, use a Design Analysis to establish the Design Clear Zone that presents the tradeoffs associated with the decision. Provide information on the benefits and effects of the Design Clear Zone selected in the Design Analysis, including safety, aesthetics, the environment, economics, modal needs, and access control. Although not a WSDOT policy document on clear zone, Chapter 10 of the AASHTO *Roadside Design Guide* provides information to consider when performing a Design Analysis in urbanized areas.



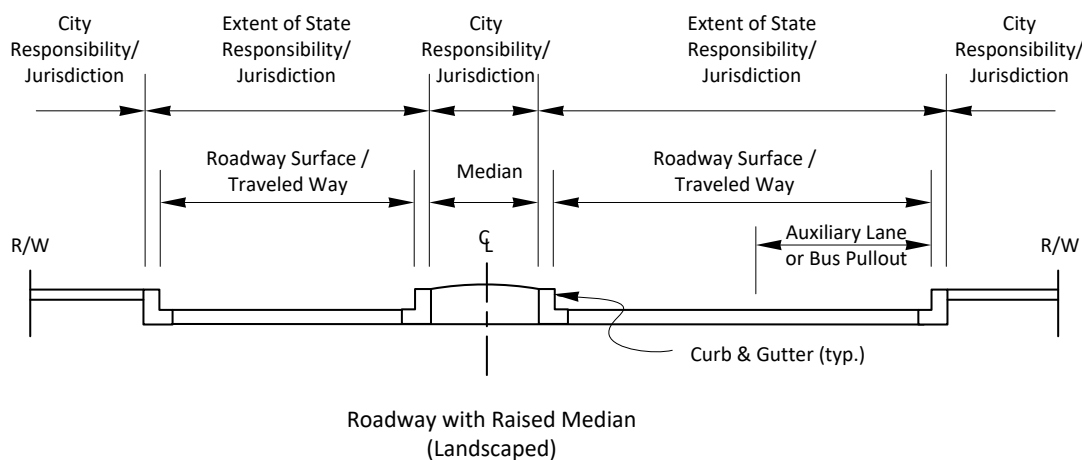
In curbed sections, and where applicable (e.g. parking), provide an 18-inch operational offset beyond the face of curb for lateral clearance to accommodate opening car doors or large side mirrors.

### 1600.02(2) Design Clear Zone Inside Incorporated Cities and Towns

For managed access state highways within an urban area, it might not be practicable or appropriate to provide the Design Clear Zone distances shown in [Exhibit 1600-2](#). Roadways within an urban area generally have curbs and sidewalks and might have objects such as trees, poles, benches, trash cans, landscaping, and transit shelters along the roadside.

For projects on city streets as state highways that include work in those areas that are the city's responsibility and jurisdiction (see [Exhibit 1600-1](#)), design the project using the city's development/design standards. The standards adopted by the city must meet the requirements set by the City Design Standards Committee for all arterial projects, bike projects, and federal-aid projects. See the [Local Agency Guidelines](#), Chapter 42, for more information on this Committee.

#### Exhibit 1600-1 City and State Responsibilities and Jurisdictions



#### 1600.02(2)(a) Roadside and Median

For managed access state highways inside incorporated cities, it is the city's responsibility to establish an appropriate Design Clear Zone in accordance with guidance contained in the City and County Design Standards ([Local Agency Guidelines](#), Chapter 42.) [Exhibit 1600-1](#) shows an example of state and city responsibilities and jurisdictions. Document the Design Clear Zone established by the city in the Design Documentation Package. Have the responsible transportation official from the city (e.g., City Engineer) document the Design Clear Zone, and their acknowledgement and acceptance of the design and maintenance responsibilities for project roadsides and medians, in a letter addressed to WSDOT, and file this letter as part of the local agency coordination in the Design Documentation Package. Respond to the sender acknowledging receipt.

### 1600.02(3) Design Clear Zone and Calculations

Use [Exhibit 1600-2](#) to determine the Design Clear Zone based on posted speed, sideslopes, and traffic volume at any given location. Note that there are no clear zones distances in the table for 3H:1V fill slopes. Although fill slopes between 4H:1V and 3H:1V are considered traversable if

free of fixed objects, these slopes are defined as nonrecoverable slopes. A vehicle might be able to begin recovery on the shoulder, but likely will not be able to further this recovery until reaching a flatter area (4H:1V or flatter) at the toe of the slope. Under these conditions, the Design Clear Zone distance is called a recovery area. The method used to calculate the recovery area and an example are shown in [Exhibit 1600-4](#).

For ditch sections, the following criteria determine the Design Clear Zone:

(a) For ditch sections with foreslopes 4H:1V or flatter (see [Exhibit 1600-5](#), Case 1, for an example), the Design Clear Zone distance is the greater of the following:

- The Design Clear Zone distance for a 10H:1V cut section based on speed and the average daily traffic (ADT); or
- A horizontal distance of 5 feet beyond the beginning of the backslope.

When a backslope steeper than 3H:1V continues for a horizontal distance of 5 feet beyond the beginning of the backslope, it is not necessary to use the 10H:1V cut slope criteria.

(b) For ditch sections with foreslopes steeper than 4H:1V and backslopes steeper than 3H:1V, the Design Clear Zone distance is 10 feet horizontal beyond the beginning of the backslope (see [Exhibit 1600-5](#), Case 2, for an example).

(c) For ditch sections with foreslopes steeper than 4H:1V and backslopes 3H:1V or flatter, the Design Clear Zone distance is the distance established using the recovery area formula (see [Exhibit 1600-4](#); also see [Exhibit 1600-5](#), Case 3, for an example).

### 1600.03 Mitigation Guidance

There are three general categories of features to be mitigated: sideslopes, fixed objects, and water. This section provides guidance for determining when these objects are to be mitigated. For each case, the following conditions need consideration:

- Locations with an expected elevated crash frequency.
- Locations with pedestrian and bicyclist usage (See Chapters [1510](#), Pedestrian Facilities, [1515](#), Shared-Use Paths, and [1520](#), Roadway Bicycle Facilities).
- Locations where speed management measures are present or contemplated (See [Chapter 1103](#)).
- Locations with playgrounds, monuments, and other locations with high social value.
- Locations where redirection landforms, also referred to as earth berms, were installed to mitigate objects located in depressed medians and at roadsides. They were constructed of materials that provided support for a traversing vehicle. With slopes in the range of 2H:1V to 3H:1V, they were intended to redirect errant vehicles. The use of redirection landforms has been discontinued as a means for mitigating fixed objects. Where redirection landforms currently exist as mitigation for a fixed object, provide designs where the landforms, and the feature(s) they were intended to mitigate, are removed, relocated, made crashworthy, or shielded with barrier.

The use of a traffic barrier for features other than those described below requires justification.

## 1600.03(1) Side Slopes

### 1600.03(1)(a) Fill Slopes

Fill slopes can increase the crash potential for an errant vehicle with the degree of severity dependent upon the slope and height of the fill. Providing fill slopes that are 4H:1V or flatter can mitigate this condition. If flattening the slope is not feasible or cost-effective, the installation of a barrier might be appropriate. [Exhibit 1600-6](#) represents a selection procedure used to determine whether a fill sideslope constitutes a condition for which a barrier is a cost-effective mitigation. The curves shown on [Exhibit 1600-6](#) are based on the severity indexes and represent the points where total costs associated with a traffic barrier are equal to the predicted cost of crashes over the service life for selected slope heights without traffic barrier. If the ADT and height of fill intersect on the “Barrier Recommended” side of the embankment slope curve, then provide a barrier if flattening the slope is not feasible or cost-effective.

Do not use [Exhibit 1600-6](#) for slope design. Design slopes consistent with guidance in [Chapter 1239](#), evaluating designs with clear, traversable slopes before pursuing a barrier option. Also, if [Exhibit 1600-6](#) indicates that barrier is not recommended at a slope, that result is not justification for a Design Analysis. For example, if the ADT is 4,000 and the embankment height is 10 feet, barrier might be cost-effective for a 2H:1V slope, but not for a 2.5H:1V slope. This process only addresses the crash potential on the slope. Objects on the slope can compound the condition. Where barrier is not cost-effective, use the recovery area formula to evaluate fixed objects on critical fill slopes less than 10 feet high.

### 1600.03(1)(b) Cut Slopes

A traversable cut slope reduces crash potential. The exception is a rock cut with a rough face that might cause vehicle snagging rather than providing relatively smooth redirection.

Analyze the location and evaluate the roadside characteristics, crash potential, and other benefits of treatment of rough rock cuts located within the Design Clear Zone. Conduct an individual investigation for each rock cut or group of rock cuts. A cost-effectiveness analysis that considers the consequences of doing nothing, removal, smoothing of the cut slope, grading at the base of the rock cut to provide a smooth surface, and other viable options to reduce the severity of the condition can be used to determine the appropriate treatment. Some potential mitigative options are roadside barrier and rumble strips.

## 1600.03(2) Fixed Objects

Use engineering judgment when considering the following objects for mitigation:

- Wooden poles or posts with cross-sectional areas greater than 16 square inches that do not have breakaway features.
- Signs, illumination, cameras, weather stations, and other items mounted on non-breakaway poles, cantilevers, or bridges.
- Trees with a diameter of 4 inches or more, measured at 6 inches above the ground surface.
- Fixed objects extending above the ground surface by more than 4 inches; for example, boulders, concrete bridge rails, signal/electrical/ITS cabinets, piers, and retaining walls.
- Drainage elements, such as culvert and pipe ends.

### 1600.03(2)(a) Trees

When evaluating new plantings or existing trees in the Design Clear Zone, consider the maximum allowable diameter of 4 inches, measured at 6 inches above the ground when the tree has matured. When removing trees within the Design Clear Zone, complete removal of stumps is preferred. However, to avoid significant disturbance of the roadside vegetation, larger stumps may be mitigated by grinding or cutting them flush to the ground and grading around them.

Removal of trees may reduce the severity of impacts of roadway departure. It is recognized that different facilities have different needs and considerations, and these issues are considered in any design. For instance, removal of trees within the Design Clear Zone may not be desirable in suburban, urban, or urban core areas, or in other land use contexts that provide for non-motorized uses, such as a forest, park, or within a scenic and recreational highway. In these situations, analyze crash reports' contributing factors to determine whether roadside vegetation is contributing to the severity of crashes. If large vegetation is removed, consult guidance contained in established vegetation management plans, corridor plans, or the [WSDOT Roadside Manual](#). Additional guidance for maintenance of roadside vegetation can be found for some routes in the Memorandum of Understanding between the US Forest Service and WSDOT, [Highways Over National Forest Lands](#), dated July 2002. In incorporated cities, refer to guidance in [1600.02\(2\)](#).

### 1600.03(2)(b) Mailboxes

For mailboxes located within the Design Clear Zone, provide supports and connections as shown in the [Standard Plans](#). The height from the ground to the bottom of the mailbox is 3 feet 3 inches. This height may vary from 3 feet 3 inches to 4 feet if requested by the mail carrier. If the desired height is to be different from 3 feet 3 inches, provide the specified height in the contract plans. (See [Exhibit 1600-7](#) for installation guidelines.) Coordinate with homeowners when upgrading mailboxes.

Where sidewalks are present, contact the postal service to determine the most appropriate mailbox location. Locate mailboxes on limited access highways in accordance with [Chapter 530](#), Limited Access. A turnout, as shown in [Exhibit 1600-7](#), is not needed on limited access highways with shoulders of 6 feet or more where only one mailbox is to be installed. On managed access highways, mailboxes are to be on the right-hand side of the road in the postal carrier's direction of travel. Avoid placing mailboxes along high-speed, high-volume highways. Locate Neighborhood Delivery and Collection Box Units outside the Design Clear Zone.

### 1600.03(2)(c) Culvert Ends

Provide a traversable end treatment when the culvert end section or opening is within the Design Clear Zone. This can be accomplished for small culverts by beveling the end to match the sideslope, with a maximum of 4 inches extending out of the sideslope.

Bars might be needed to provide a traversable opening for larger culverts. Place bars in the plane of the culvert opening in accordance with the [Standard Plans](#) when:

- Single cross-culvert opening exceeds 40 inches, measured parallel to the direction of travel.
- Multiple cross-culvert openings that exceed 30 inches each, measured parallel to the direction of travel.

- Culvert approximately parallel to the roadway that has an opening exceeding 24 inches, measured perpendicular to the direction of travel.

Bars are permitted where they will not significantly affect the stream hydraulics and where debris drift is minor. Consult the region Maintenance Office to verify these conditions. If debris drift is a concern, consider options to reduce the amount of debris that can enter the pipe (see the [Hydraulics Manual](#)). Other treatments are extending the culvert to move the end outside the Design Clear Zone or installing a traffic barrier.

#### **1600.03(2)(d) Signposts**

Whenever possible, locate signs behind the standard run, but not the end terminals, of existing or planned traffic barrier installations to eliminate the need for breakaway posts, and place them such that the sign face is behind the barrier. (See [Chapter 1020](#) for additional information regarding the placement of signs.) Use the [MUTCD](#) to guide placement of the warning sign.

Signposts with cross-sectional areas greater than 16 square inches that are within the Design Clear Zone and not located behind a barrier are to have breakaway features as shown in the [Standard Plans](#).

Sign bridges and cantilever sign supports are designed for placement outside the Design Clear Zone or must be shielded by barrier.

#### **1600.03(2)(e) Traffic Signal Standards/Posts/Supports**

Breakaway signal posts generally are not feasible or desirable, and barrier is not generally an option due to constraints typically found at intersection locations. To reduce potential for drivers making contact with posts, and to avoid impeding the movement of pedestrian or bicyclist traffic in the vicinity, locate posts in accordance with [Chapter 1330](#).

For ramp meter systems, single lane ramp meters use breakaway Type RM signal standards. Multilane ramp meters normally use Type II signal standards, which must either be located outside of clear zone for all adjacent roadways or be protected by some type of barrier.

#### **1600.03(2)(f) Fire Hydrants**

Fire hydrants are typically allowed on WSDOT right of way by franchise or permit. Fire hydrants that are made of cast iron can be expected to fracture on impact and can therefore be considered a breakaway device. Any portion of the hydrant that will not be breakaway must not extend more than 4 inches above the ground. In addition, the hydrant must have a stem that will shut off water flow in the event of an impact. Provide mitigation to address potential vehicle impact with hydrant types not expected to fracture on impact.

#### **1600.03(2)(g) Utility Poles**

Since utilities often share the right of way, utility objects such as poles are often located along the roadside. It is normally undesirable or infeasible to install barrier for all of these objects, so mitigation is usually in the form of relocation (underground or to the edge of the right of way) or delineation. In some instances where there is a history of impacts with poles and relocation is not possible, a breakaway design might be appropriate.

Evaluate roadway geometry and crash history as an aid in determining locations that exhibit the greatest need. Contact the Headquarters (HQ) Design Office for information on breakaway features. Coordinate with the HQ Utilities Unit when appropriate.

For policy and guidance on locating utility poles along state highways, also see Chapter 9 of the *Utilities Manual*. Document the determination of appropriate mitigative measures and coordination with the region Utilities Office.

### 1600.03(2)(h) Light Standards

Provide breakaway light standards unless fixed light standards can be justified, even if outside of the Design Clear Zone. Fixed light standards may be justified if one of the following criteria are met:

- Posted speed is below 35 MPH (See [1600.02\(1\)](#) for Design Clear Zone in urbanized and urbanizing areas, and [1600.02\(2\)](#) in cities).
- Mounted on barrier (top or elbow mount).
- Behind traffic barrier, beyond the barrier's deflection design value (see [Chapter 1610](#)).
- Within a parking lot.
- Along isolated walkways and shared-use paths that are outside of Design Clear Zone.

Breakaway light standards require additional embankment widening to ensure proper operation, as shown in the *Standard Plans*. If this additional embankment widening cannot be constructed, such as in cases where the toe of slope will extend beyond right of way or into a water body or other sensitive area, fixed bases and traffic barrier may be considered. Document the decision to use fixed bases in the Design Documentation Package.

### 1600.03(3) Water

Water with a depth of 2 feet or more and located with a likelihood of encroachment by an errant vehicle is to be evaluated for mitigation.

Perform a benefit-cost analysis that considers the consequences of doing nothing versus installing a longitudinal barrier to determine the appropriate treatment (see [Chapter 321](#) for more information). For fencing considerations along water features see [Chapter 560](#).

### 1600.04 Medians

Median barriers are normally used on limited access, multilane, high-speed, high-volume highways. These highways generally have posted speeds of 45 mph or higher. Median barrier is normally placed on limited access state highways. Where median barrier is used on managed access highways where bicyclists, pedestrians, and transit users are present, consider providing accessible barrier openings at crossing locations. Providing access through median barrier results in openings, therefore, end treatments are needed.

Provide median barrier on full access control multilane highways with median widths of 50 feet or less and posted speeds of 45 mph or higher. Consider median barrier on highways with wider medians or lower posted speeds when there is a history of cross-median crashes. Contact the HQ Design Office for more information.

Provide a left-side shoulder when installing median barrier using width criteria given in [Chapter 1230](#). Consider a wider shoulder area where the barrier might cast a shadow on the roadway and hinder the melting of ice. (See [Chapter 1239](#) for additional criteria for placement of median barrier, [Chapter 1610](#) for information on the types of barriers that can be used, and [Chapter 1260](#) for lateral clearance on the inside of a curve to provide the needed stopping sight distance.) Consider the need to accommodate drainage as a result of the addition of median barrier treatments.

When median barrier is being placed in an existing median, identify the existing crossovers and enforcement observation points. Provide the needed median crossovers in accordance with [Chapter 1370](#), considering enforcement needs. [Chapter 1410](#) provides guidance on HOV enforcement.

## 1600.05 Other Roadside Safety Features

### 1600.05(1) Rumble Strips

Rumble strips are milled grooves or rows of raised pavement markers placed perpendicular to the direction of travel, or a continuous sinusoidal pattern milled longitudinal to the direction of travel, intended to alert inattentive drivers to a potential lane departure. A sinusoidal pattern can be used when a low noise design is desired.

The pavement receiving rumble strips needs to be in good condition and thick enough to support the rumble strips. Certain pavement types, such as open graded pavements, are not suitable for rumble strip installation. Grinding rumble strips into inadequate pavement will lead to premature deterioration of the surrounding pavement. Areas where the pavement is inadequate for rumble strip installation require removal and replacement of the existing pavement at and adjacent to the location of the rumble strip. Consult with the Region Materials Engineer to determine whether the existing pavement is adequate for rumble strip installation. The Region Materials Engineer will provide a pavement design for removing and replacing the existing pavement near the rumble strip if needed. When installing both rumble strips and recessed lane markers, follow the Standard Plan to avoid overlapping the grindings.

Installing rumble strips in bituminous surface treatment (or BST) or other thin surface treatments can expose pavement structure and lead to delamination. In new rumble strip locations where BST will be applied on an Hot Mix Asphalt (HMA) pavement, install the rumble strips in the HMA pavement before placing the BST. In existing rumble strip locations, note that a single application of BST on top of an existing rumble strip installation typically results in satisfactory rumble strip depth. Where rumble strips currently exist and an additional BST application is contemplated, evaluate whether the depth of the grooves following paving will provide their continuing function to alert drivers. If not, or in the case of an HMA overlay, it may be necessary to remove existing rumble strips and install new ones.

Provide an offset to the longitudinal paving joint so that rumble strips are not ground into the joint where practicable. For additional guidance on surface preparation and pavement stability, refer to the [WSDOT Pavement Policy](#).

The noise created when vehicle tires contact a rumble strip may adversely impact nearby residences and other land uses. Left-turning or passing vehicles, frequent passing maneuvers on two lane highways, and off-tracking of vehicles or trailers in tight radius curves, are examples of situations where incidental contact can happen. Noise impacts may be anticipated, and a low



noise rumble strip design may be warranted, when installing rumble strips in urban growth areas, and/or within 600 feet of a residence, school, church, or campground. In situations where a low noise rumble strip is desired but is not feasible, measures can still be taken to reduce incidental contact, including discontinuing the rumble strip through frequently used road approaches, through passing zones, and in tight radius curves. Contact HQ Design for more information about low noise rumble strip designs, noise mitigation strategies, and the criteria for employing them.

There are three types of rumble strip functions: roadway, shoulder, and centerline, and each are described in the following sections.

### **1600.05(1)(a) Roadway Rumble Strips**

Roadway rumble strips are placed transversely in the traveled way to alert drivers who are approaching a change of roadway condition or object that requires substantial speed reduction or other maneuvering. Some locations where advance roadway rumble strips may be placed include:

- Stop-controlled intersections
- Port of entry/customs stations
- Lane reductions where crash history shows a pattern of driver inattention, and
- Horizontal alignment changes where crash history shows a pattern of driver inattention.

They may also be placed at locations where the character of the roadway changes, such as at the end of a freeway.

Contact the HQ Design Office for additional guidance on the design and placement of roadway rumble strips.

Document decisions to use roadway rumble strips in the Design Documentation Package.

### **1600.05(1)(b) Shoulder Rumble Strips and Rumble Stripes**

Shoulder rumble strips (SRS) are placed parallel to the traveled way just beyond the edge line to warn drivers they are entering a part of the roadway not intended for routine traffic use.

Shoulder rumble stripes are rumble strips placed immediately under the shoulder delineation paint, with any excess width milled or placed outward towards the shoulder. Shoulder rumble stripes are only installed where there is insufficient space to install shoulder rumble strips per one of the standard configurations (see [Section 1600.05\(1\)\(b\)\(2\)](#)).

When shoulder rumble strips and shoulder rumble stripes are used, discontinue them where no edge stripe is present, such as at intersections and where curb and gutter are present. Discontinue shoulder rumble strips and rumble stripes where shoulder driving is allowed.

Shoulder rumble strip and rumble stripe patterns vary depending on whether bicyclists are expected to use the highway shoulder, and whether they are placed on divided or undivided highways. Rumble strip patterns for undivided highways are shallower and may be narrower than patterns used on divided highways. Rumble strips and rumble stripes installed on undivided highways also provide gaps in the pattern, providing opportunities for bicycles to move across the pattern without having to ride across the grooves. There are four shoulder rumble strip and four shoulder rumble stripe patterns. Consult the [Standard Plans](#) (rumble strips) or [Plan Sheet Library](#) (rumble stripes) for patterns and construction details.



## 1. Divided Highways

Install shoulder rumble strips on both the right and left shoulders of rural Interstate highways. Consider them on both shoulders of rural divided highways. Use the [Shoulder Rumble Strip or rumble stripe Type 1](#) pattern on divided highways.

Shoulder rumble strips [and rumble stripes](#) may be omitted under any of the following conditions:

- When another project scheduled within two years of the proposed project will overlay or reconstruct the shoulders or will use the shoulders for detours.
- When overall shoulder width is less than 4 feet wide on the left and 6 feet wide on the right. The minimum right shoulder width is reduced to 5 feet where rumble stripes are used.

## 2. Undivided Highways

Shoulder rumble strips or rumble stripes are considered on undivided highways during centerline rumble strip installation or pavement rehabilitation. A list of prospective locations are provided to regions by HQ Design as a starting point in their development of a final list. The final list is compiled based on a detailed review of the prospective locations using the following criteria. Document decisions to omit prospective locations in the final list.

Shoulder rumble strips or stripes may be omitted from a highway segment under any of the following conditions:

- Where at least 4 feet of usable shoulder between the rumble strip and the outside edge of shoulder cannot be provided. In cases where guardrail or barrier is present, increase this dimension to a minimum of 5 feet of usable shoulder. Field-verify these dimensions.
- Where downhill grades exceed 4% for more than 500 feet in length along routes where bicyclists are frequently present.
- Where sections of rumble strips are omitted as a measure to reduce noise (see [Section 1600.05\(1\)](#)).

When selecting a rumble strip or rumble stripe design, consult the [Standard Plans](#) and [Plan Sheet Library](#) for the patterns and construction details, and apply the following criteria:

- Consider using a low noise pattern, or employ measures to reduce incidental contact, in areas where noise impacts are anticipated (apply criteria in [Section 1600.05\(1\)](#)).
- Consider using a rumble stripe pattern where usable shoulder width is less than 4 feet (5 feet where barrier is present).
- The Shoulder Rumble Strip Type 2 or Type 3 pattern is used on highways with minimal bicycle traffic. Use the Shoulder Rumble Strip Type 4 pattern where the bicycle traffic level on the shoulder is determined to be high. Consult the region and Headquarters Bicycle and Pedestrian Coordinators to determine the bicycle traffic level, and engage them in decision-making processes related to the use of rumble strips or rumble stripes on bike touring routes, and/or on other routes where bicycle events are regularly held.

Document the decision to omit shoulder rumble strips or rumble stripes in a Design Analysis, when that decision is outside of the policy provided in this section (see [Chapter 300](#).)

### **1600.05(1)(c) Centerline Rumble Strips**

Centerline rumble strips are installed on the centerline of undivided highways to alert drivers that they are entering the opposing lane. They are installed with no differentiation between passing permitted and no passing areas. Refresh pavement markings when removed by centerline rumble strips.

Centerline rumble strips are typically installed on rural highways where the posted speed is 45 mph or higher. They may also be installed on urban routes with posted speeds as low as 35 mph. A list of prospective centerline rumble strip installation locations are provided to regions by HQ Design as a starting point in their development of a final list. The final list is compiled based on a detailed review of the prospective locations using the following criteria.

- Field verify lane and shoulder widths. See [Chapter 1230](#) for guidance on lane and shoulder widths. Centerline rumble strips are only installed where the combined lane and shoulder width in either direction is greater than 12 feet.
- In locations where the combined lane and shoulder width in either direction is 14 feet or less, consider the level of bicyclist and pedestrian use along the route before installing centerline rumble strips. When drivers shift their lane position away from centerline to avoid the rumble strips, they are moving closer to pedestrians and bicyclists on the shoulder.
- Consider using a low noise rumble strip design in locations where noise is an issue, or employ measures for reducing incidental contact where a low noise design is not feasible (apply criteria in [Section 1600.05\(1\)](#)).
- In urban areas, do not consider installing rumble strips where the need to interrupt the rumble strip pattern to accommodate left-turning vehicles is very frequent, or where the posted speed is 35 mph and below.
- Do not use centerline rumble strips where two way left-turn lanes exist.

Document the decision to omit centerline rumble strips in a Design Analysis, when that decision is outside of the policy provided in this section (see [Chapter 300](#).)

### **1600.05(2) Headlight Glare Considerations**

Headlight glare from opposing traffic is most common between opposing main line traffic. Glare screens can be used to mitigate this condition. Other conditions for which glare screen might be appropriate are:

- Between a highway and an adjacent frontage road, multi-use path, or parallel highway, especially where opposing headlights might seem to be on the wrong side of the driver.
- At an interchange where an on-ramp merges with a collector-distributor and the ramp traffic might be unable to distinguish between collector and main line traffic.
- Where headlight glare is a distraction to adjacent property owners. Playgrounds, ball fields, and parks with frequent nighttime activities might benefit from screening if headlight glare interferes with these activities.

Glare screening is normally not justifiable where the median width exceeds 20 feet, and the ADT is less than 20,000 vehicles per day. Document the decision to use glare screening using the following criteria:

- Higher frequency of night crashes compared to similar locations or based on statewide experience.
- Higher than normal ratio of night-to-day crashes.
- Unusual distribution or concentration of nighttime crashes.
- Over-representation of older drivers in night crashes.
- Combination of horizontal and vertical alignment, particularly where the roadway on the inside of a curve is higher than the roadway on the outside of the curve.
- Direct observation of glare.
- Public complaints concerning glare.

There are currently three basic types of glare screening available: chain link (see the [Standard Plans](#)), vertical blades, and concrete barrier (see [Exhibit 1600-8](#)).

When the glare is temporary (due to construction activity), consider traffic volumes, alignment, duration, presence of illumination, and type of construction activity. Glare screening may be used to reduce rubbernecking associated with construction activity, but less expensive methods, such as plywood that seals off the view of the construction area, might be more appropriate.

## 1600.06 Documentation

Refer to [Chapter 300](#) for design documentation requirements.

## 1600.07 References

### 1600.07(1) Federal/State Laws and Codes

[Revised Code of Washington \(RCW\) 47.24.020\(2\)](#), Jurisdiction, control

[RCW 47.32.130](#), Dangerous objects and structures as nuisances

### 1600.07(2) Design Guidance

[Highway Safety Manual, AASHTO](#)

[Local Agency Guidelines](#) (City and County Design Standards), M 36-63, WSDOT

[Roadside Design Guide, AASHTO, 2011](#)

[Standard Plans for Road, Bridge, and Municipal Construction](#) (Standard Plans), M 21-01, WSDOT

### 1600.07(3) Supporting Information

[A Policy on Geometric Design of Highways and Streets](#) (Green Book), AASHTO, 2011

*Understanding Design Clear Zone* – This e-learning course for WSDOT employees covers how to determine the appropriate Design Clear Zone for recoverable and nonrecoverable slopes as well as ditches. Request this training via the web-based Learning Management System.

*Highways Over National Forest Lands*, MOU, 2013, US Forest Service and WSDOT,  
[www.wsdot.wa.gov/publications/manuals/m22-50.htm](http://www.wsdot.wa.gov/publications/manuals/m22-50.htm)

*Utilities Manual*, M 22-87, WSDOT. Chapter 9 provides Control Zone guidance for utilities in the WSDOT right of way.

Exhibit 1600-2 Design Clear Zone Distance Table

Posted Speed (mph)	Average Daily Traffic	Cut Section (Backslope) (H:V)						Fill Section (H:V)					
		3:1	4:1	5:1	6:1	8:1	10:1	3:1	4:1	5:1	6:1	8:1	10:1
35 or Less		The Design Clear Zone Distance is 10 ft											
40	Under 250	10	10	10	10	10	10	*	13	12	11	11	10
	251 – 800	11	11	11	11	11	11	*	14	14	13	12	11
	801 – 2,000	12	12	12	12	12	12	*	16	15	14	13	12
	2,001 – 6,000	14	14	14	14	14	14	*	17	17	16	15	14
	Over 6,000	15	15	15	15	15	15	*	19	18	17	16	15
45	Under 250	11	11	11	11	11	11	*	16	14	13	12	11
	251 – 800	12	12	13	13	13	13	*	18	16	14	14	13
	801 – 2,000	13	13	14	14	14	14	*	20	17	16	15	14
	2,001 – 6,000	15	15	16	16	16	16	*	22	19	17	17	16
	Over 6,000	16	16	17	17	17	17	*	24	21	19	18	17
50	Under 250	11	12	13	13	13	13	*	19	16	15	13	13
	251 – 800	13	14	14	15	15	15	*	22	18	17	15	15
	801 – 2,000	14	15	16	17	17	17	*	24	20	18	17	17
	2,001 – 6,000	16	17	17	18	18	18	*	27	22	20	18	18
	Over 6,000	17	18	19	20	20	20	*	29	24	22	20	20
55	Under 250	12	14	15	16	16	17	*	25	21	19	17	17
	251 – 800	14	16	17	18	18	19	*	28	23	21	20	19
	801 – 2,000	15	17	19	20	20	21	*	31	26	23	22	21
	2,001 – 6,000	17	19	21	22	22	23	*	34	29	26	24	23
	Over 6,000	18	21	23	24	24	25	*	37	31	28	26	25
60	Under 250	13	16	17	18	19	19	*	30	25	23	21	20
	251 – 800	15	18	20	20	21	22	*	34	28	26	23	23
	801 – 2,000	17	20	22	22	23	24	*	37	31	28	26	25
	2,001 – 6,000	18	22	24	25	26	27	*	41	34	31	29	28
	Over 6,000	20	24	26	27	28	29	*	45	37	34	31	30
65	Under 250	15	18	19	20	21	21	*	33	27	25	23	22
	251 – 800	17	20	22	22	24	24	*	38	31	29	26	25
	801 – 2,000	19	22	24	25	26	27	*	41	34	31	29	28
	2,001 – 6,000	20	25	27	27	29	30	*	46	37	35	32	31
	Over 6,000	22	27	29	30	31	32	*	50	41	38	34	33
70	Under 250	16	19	21	21	23	23	*	36	29	27	25	24
	251 – 800	18	22	23	24	26	26	*	41	33	31	28	27
	801 – 2,000	20	24	26	27	28	29	*	45	37	34	31	30
	2,001 – 6,000	22	27	29	29	31	32	*	50	40	38	34	33
	Over 6,000	24	29	31	32	34	35	*	54	44	41	37	36

**Notes:**

This exhibit applies to:

- All state highways outside incorporated cities.
- Limited access state highways within cities.

For Roadside and Median areas on managed access state highways within incorporated cities, see [1600.02](#) for guidance. Curb is not considered adequate to redirect an errant vehicle.

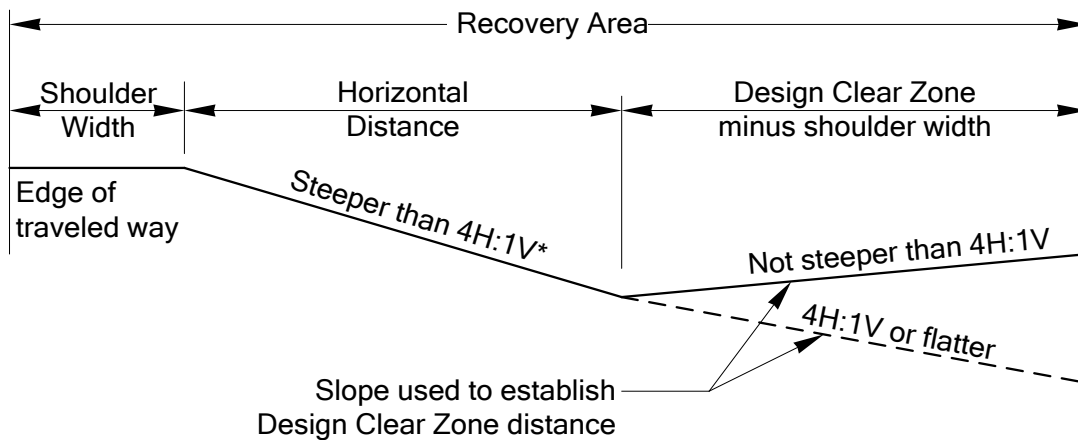
Design Clear Zone distances are given in feet, measured from the edge of traveled way.

\*When the fill section slope is steeper than 4H:1V, but not steeper than 3H:1V, the Design Clear Zone distance is modified by the recovery area formula (see [Exhibit 1600-4](#)) and is referred to as the recovery area. The basic philosophy behind the recovery area formula is that the vehicle can traverse these slopes but cannot recover (control steering); therefore, the horizontal distance of these slopes is added to the Design Clear Zone distance to form the recovery area.

**Exhibit 1600-3 Design Clear Zone Inventory**

**See:** [www.wsdot.wa.gov/design/support.htm](http://www.wsdot.wa.gov/design/support.htm) for form template

## Exhibit 1600-4 Recovery Area



\* Recovery area normally applies to slopes steeper than 4H:1V, but not steeper than 3H:1V. For steeper slopes, the recovery area formula may be used as a guide if the embankment height is 10 ft or less.

**Formula:**

Recovery area = (shld. width) + (horizontal distance) + (Design Clear Zone distance – shld. width)

**Example: Fill section (slope 3H:1V or steeper)****Conditions:**

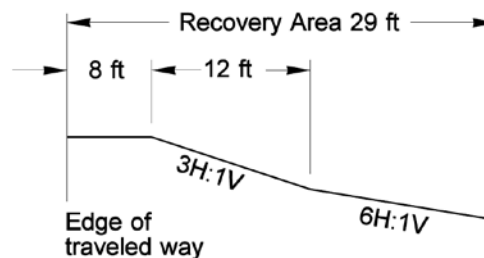
Speed = 45 mph  
 Traffic = 3,000 ADT  
 Slope = 3H:1V

**Criteria:**

Slope 3H:1V → Use recovery area formula

Recovery area = (shld. width) + (horizontal distance) + (Design Clear Zone distance – shld. width)  
 = 8 + 12 + (17-8)

**Recovery area = 29 feet**



**Exhibit 1600-5 Design Clear Zone Examples for Ditch Sections**

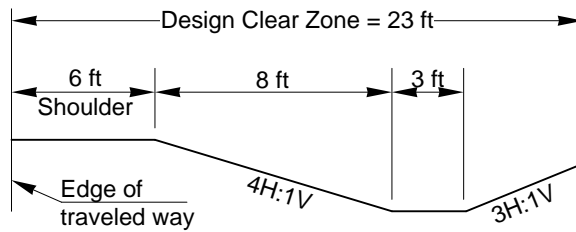
**Case 1: Cut section with ditch (foreslope 4H:1V of flatter)**

**Conditions:**

- Speed = 55 mph
- Traffic = 4,200 ADT
- Slope = 4H:1V

**Criteria:**

- Greater of:
  - (1) Design Clear Zone for 10H:1V cut section, 23 ft
  - (2) 5 feet horizontal beyond beginning of back slope, 22 feet



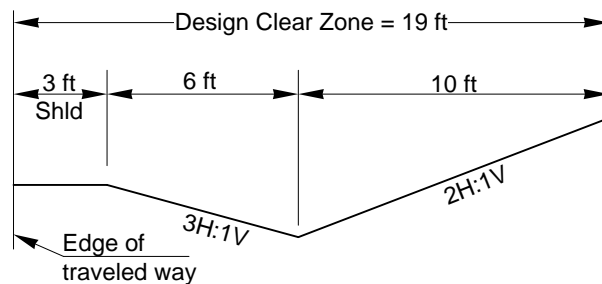
**Design Clear Zone = 23 feet**

**Case 2: Cut section with ditch (foreslope steeper than 4H:1V and backslope steeper than 3H:1V)**

**Conditions:** NA

**Criteria:** 10 feet horizontal beyond beginning of backslope

**Design Clear Zone = 19 feet**



**Case 3: Cut section with ditch (foreslope 3H:1V or steeper and backslope not steeper than 3H:1V)**

**Conditions:**

- Speed = 45 mph
- Traffic = 3,000 ADT
- Foreslope = 2H:1V
- Backslope = 4H:1V

**Criteria:** Use recovery area formula

**Recovery area** = (shoulder width) + (horizontal distance) + (Design Clear Zone distance – shoulder width)

$$= 6 + 6 + (15 - 6) = 21$$

**Recovery Area = 21 feet**

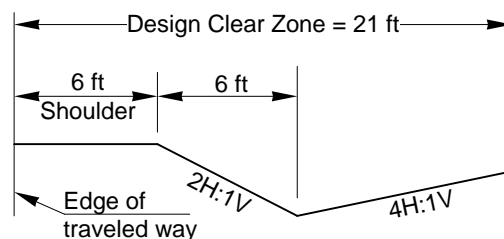
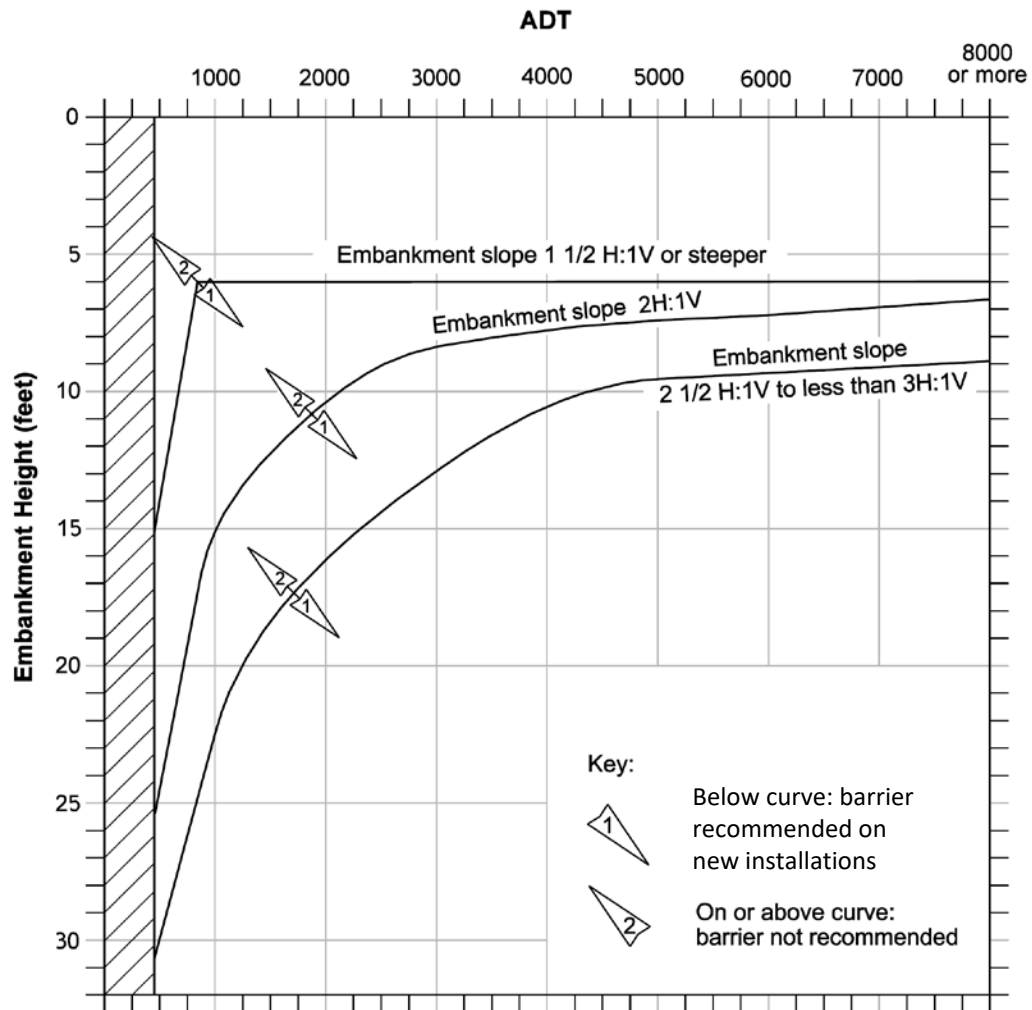




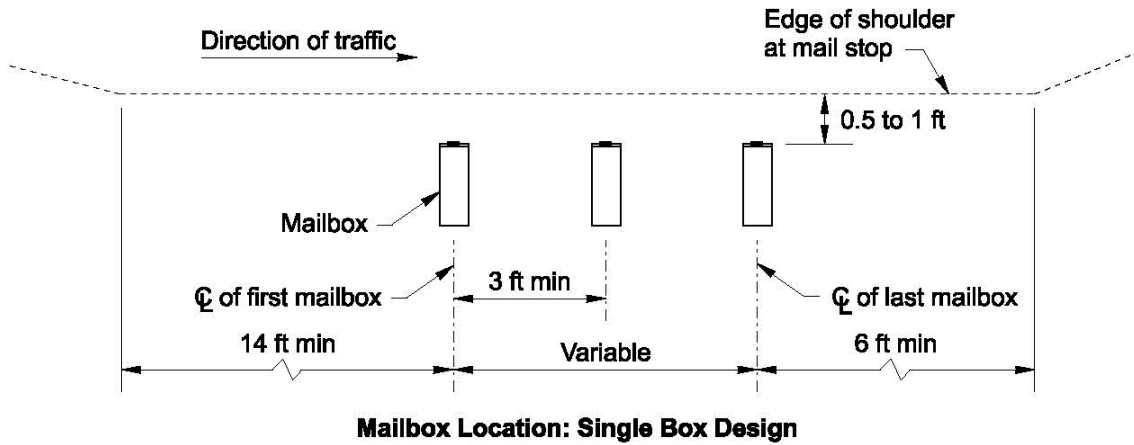
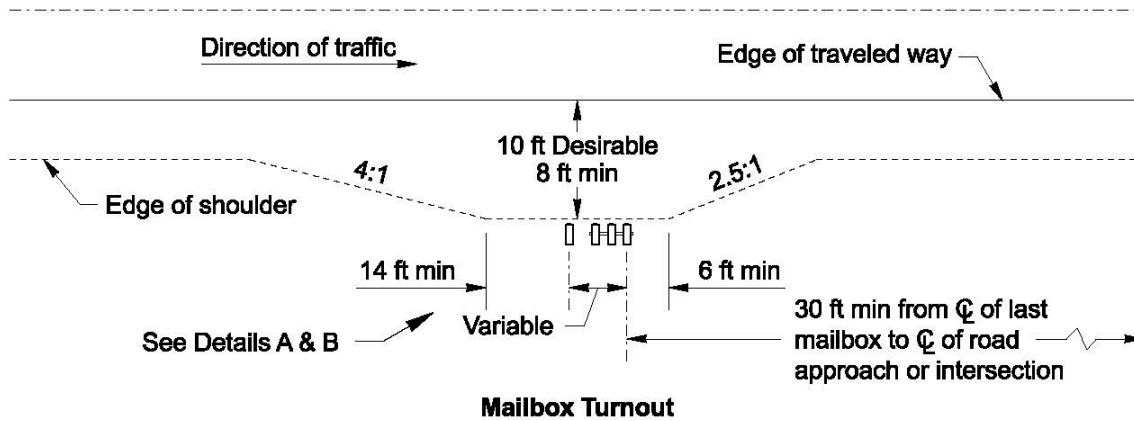
Exhibit 1600-6 Guidelines for Embankment Barrier



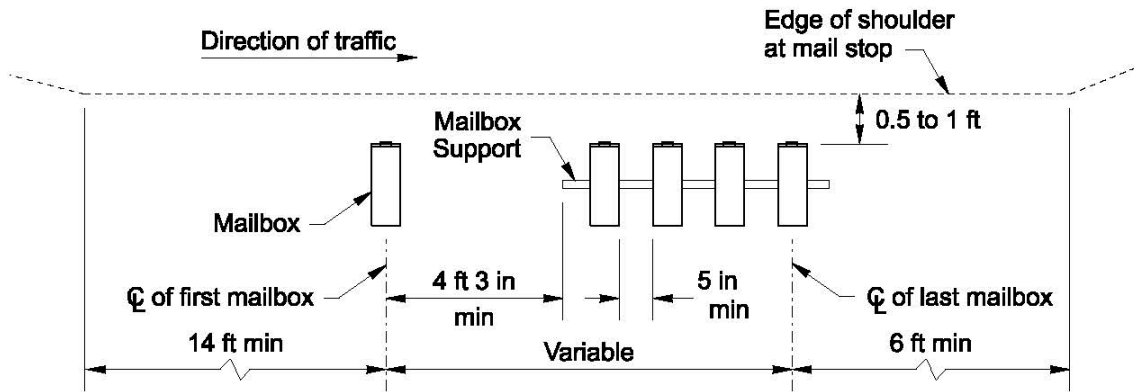
**Note:**

Routes with ADTs under 400 may be evaluated on a case-by-case basis.

Exhibit 1600-7 Mailbox Location and Turnout Design

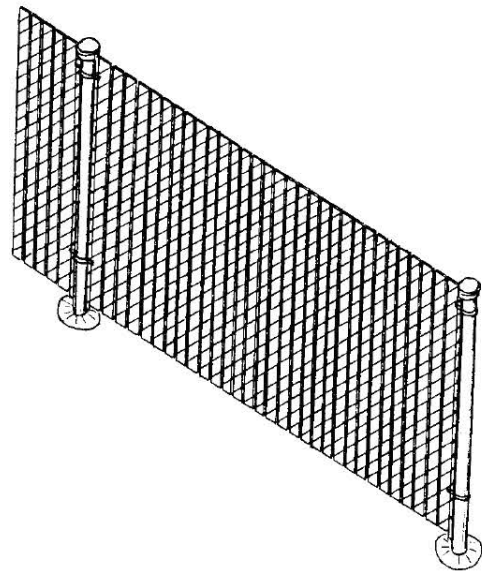
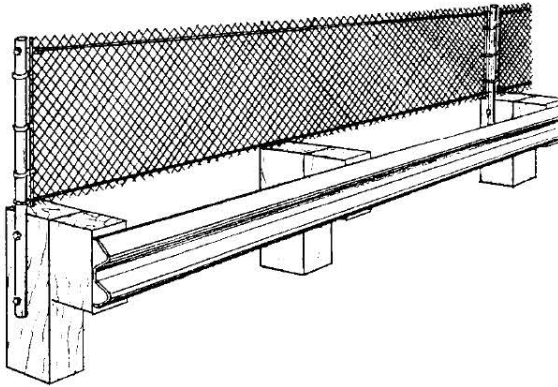


**Mailbox Location: Single Box Design**  
Detail A

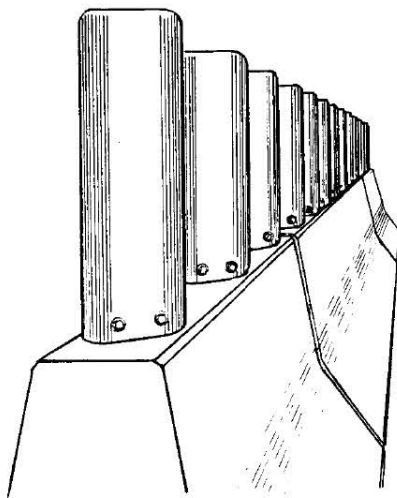


**Mailbox Location: Multiple Box Design**  
Detail B

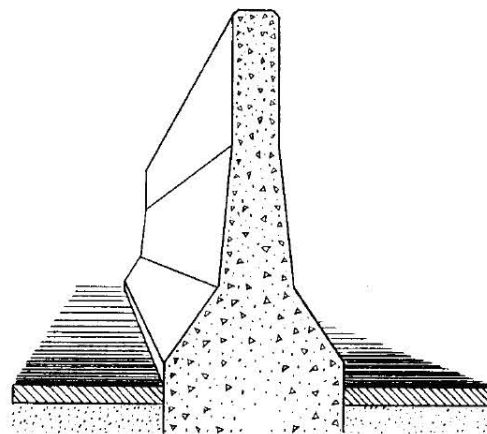
Exhibit 1600-8 Glare Screens



Chain Link



Vertical Blades



Concrete Barrier



1610.01	Introduction
1610.02	Barrier Impacts
1610.03	General Barrier Design Considerations
1610.04	Beam Guardrail
1610.05	High-Tension Cable Barrier
1610.06	Concrete Barrier
1610.07	Bridge Traffic Barriers
1610.08	Other Barriers
1610.09	References

**Chapter Organization:** The first sections (Introduction and Barrier Impacts) present information to consider when deciding whether to install a barrier. The next section (General Barrier Design Considerations) contains guidance common to ALL barrier types, such as deflection distance, length of need and sight distance. The remaining sections present design information organized by specific barrier type (beam guardrail, cable barrier, etc.).

Refer to the *Design Manual Glossary* for many of the terms used in this chapter.

Refer to [Chapter 300](#) for design documentation requirements.

## 1610.01 Introduction

WSDOT uses traffic barriers to reduce the overall severity of crashes. Consideration is given as to whether a barrier is preferable to the recovery area it may replace. In some cases, installation of a traffic barrier may result in more crashes as it presents an object that can be struck. Barriers are designed so that such encounters might be less severe and not lead to secondary or tertiary crashes. However, traffic barriers are not guaranteed to redirect an impacting vehicle without resulting injury to its occupants or triggering additional crashes. Barrier performance is affected by the characteristics of the vehicles that collide with them. Different vehicles will react differently given the characteristics and dynamics of the crash. Therefore, vehicles will be decelerated and redirected differently given the size, weight and direction of force imparted from the vehicle to the barrier.

Barriers are not placed with the assumption that the system will restrain or redirect all vehicles in all conditions. It is recognized that the designer cannot design a system that will address every potential crash situation. Instead, barriers are placed with the assumption that, under typical crash conditions, they might decrease the potential for excessive vehicular deceleration or excessive vehicle redirection when compared to the location without the barrier.

Traffic barriers do not prevent crashes or injuries from occurring. They often lower the potential severity for crash outcomes. Consequently, barriers should not be used unless a reduced crash severity potential is likely. No matter how well a barrier system is designed, optimal performance is dependent on drivers' proper maintenance and operation of their vehicles and the proper use of passenger restraint systems. The ultimate choice of barrier type and placement should be made by gaining an understanding of site and traffic conditions, having a

thorough understanding of and applying the criteria presented in [Chapters 1600](#) and 1610, and using engineering judgment.

Barrier systems and vehicle fleets continue to evolve. The choice of a barrier is based on the characteristics of today's vehicle fleet and testing criteria, not on speculative assumptions of future vehicle designs. This continuum of change does not allow engineers to predict the future with any degree of certainty. Consequently, engineering decisions need to be made based on the most reliable and current information.

Engineers are constantly striving to develop more effective design features to improve highway safety. However, economics, asset management and maintenance needs, and feasibility do not permit the deployment of new designs as soon as they become available on the market or are invented by a manufacturer. Further, most new designs only make marginal changes to systems and do not imply that old designs are unsafe or need modification.

Solutions may consider crash frequency and severity. As discussed previously, performance of the system relies on the interaction of the vehicle, driver, and system design at any given location. Additionally, the ability to safely access, maintain and operate over time is incorporated into the final barrier decision.

When barriers are crash-tested, it is impossible to replicate the innumerable variations in highway conditions under which the barrier applications occur. Therefore, barriers are crash-tested under standardized conditions. These standard conditions were previously documented in National Cooperative Highway Research Program (NCHRP) Reports 230 and 350. These guidelines have been updated and are now presented in the AASHTO publication, *Manual for Assessing Safety Hardware* (MASH).

As roadside safety hardware changes occur on the highway system they will use MASH crash testing criteria instead of NCHRP Report 350. To learn more about WSDOT's plan for implementing MASH-compliant hardware see the following website:

🔗 <http://www.wsdot.wa.gov/Design/Policy/RoadsideSafety.htm>

### **1610.01(1) Site Constraints**

Site constraints play a major role in decisions regarding guardrail selection and placement. Depending on the location, these constraints may include (but are not limited to) environmental considerations, topographic challenges, restricted right-of-way, geologic concerns or conflicts with other infrastructure to name just a few. Document barrier location decisions, including any site constraints encountered that influenced those decisions. A decision to install barrier using criteria outside the guidance provided in this chapter requires a Design Analysis (See [Chapter 300](#)).

### **1610.02 Barrier Impacts**

Engineering judgment is required in determining the appropriate placement of barrier systems, therefore consider the location of the system and the possible impacts the barrier may have to other highway objectives.

#### **1610.02(1) Assessing Impacts to Stormwater and Wetlands**

The presence of stormwater facilities or wetlands influence the choice and use of barrier systems. For example, the placement of concrete barrier may increase the amount of

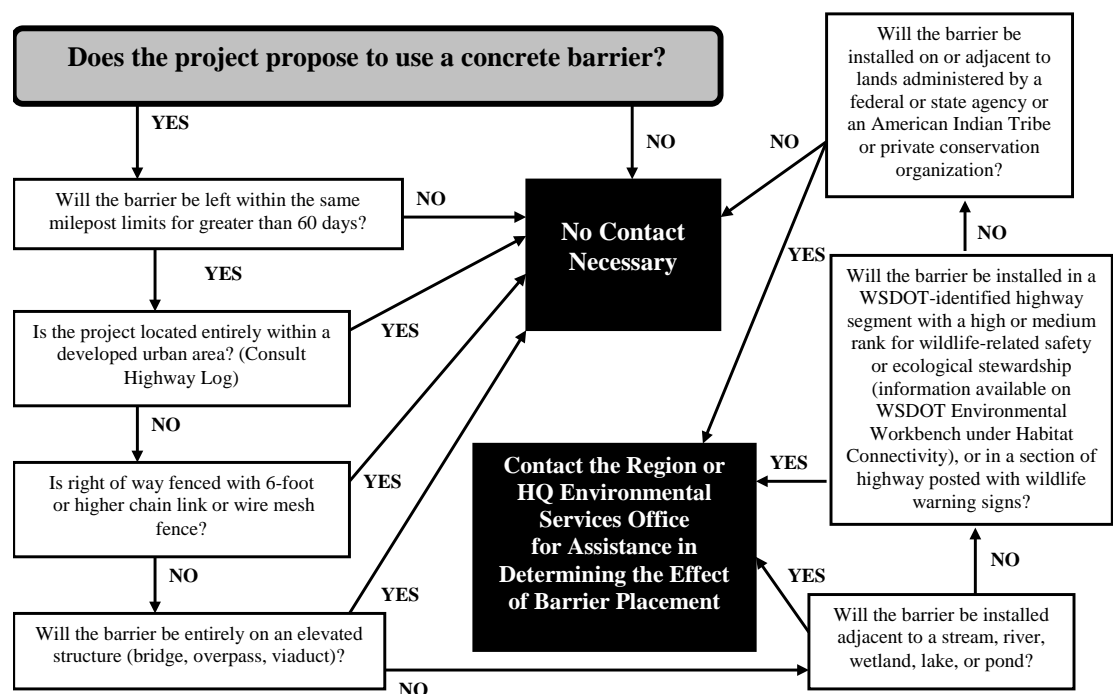
impervious surface, which could then result in retrofit or reconstruction of the existing retention/detention systems and environmental impact requirements and studies. Assess whether concrete barrier or beam guardrail placement will cause the need for an evaluation by the HQ Environmental Services Office. Conduct this evaluation early in the project's development process to allow adequate time for discussion of options.

### 1610.02(2) Assessing Impacts to Wildlife

The placement of concrete barriers in locations where wildlife frequently cross the highway can influence wildlife-vehicle crash potential. When wildlife encounters physical barriers that are difficult to see beyond or cross, such as concrete barriers, they often stop or move parallel to those barriers, increasing their time on the highway and their exposure.

Traffic-related wildlife mortality may play a role in the decline of some species listed under the Endangered Species Act. To address wildlife concerns, see [Exhibit 1610-1](#) to assess whether barrier placement needs to have an evaluation by the HQ Environmental Services Office to determine its effect on wildlife. Conduct this evaluation early in the project development process to allow adequate time for discussion of options.

#### Exhibit 1610-1 Concrete Barrier Placement Guidance: Assessing Impacts to Wildlife



### 1610.03 General Barrier Design Considerations

See [Chapter 1105](#) Design Element Selection for guidance regarding required design elements for the various different project types (programs and subprograms).

[Chapter 1120](#) identifies those elements and features to be evaluated and potentially addressed during the course of a Preservation project.

Follow the guidance in this chapter for any project that introduces new barrier onto the roadside (including median section) and follow the guidance in [Chapter 1600](#) for removal of barrier that is not needed. Slope flattening is recommended when the crash reduction benefit justifies the additional cost to eliminate the need for barrier.

When selecting a barrier, consider the barrier system's deflection characteristics, cost, maintainability and impacts to traffic flow during repair. Barriers are categorized as flexible, semi-rigid, or rigid depending on their deflection characteristics. (See [Exhibit 1610-3](#)). Barrier types include:

- Beam Guardrail
- Cable Barrier
- Concrete Barrier
- Bridge Traffic Barrier
- Other Barriers

Since non-rigid systems typically sustain more damage during an impact, consider the amount of traffic exposure maintenance crews might incur with the more frequent need for repairs.

The costs for procuring and maintaining the barrier system are important factors when considering what system to install. Considerations may include:

- Consultation with the Area Maintenance Superintendent to identify needs or recommendations.
- Drainage, alignment, and drifting snow or sand are considerations that can influence the selection of barrier type. Beam guardrail and concrete barrier can contribute to snow drifts. Consider long-term maintenance costs associated with snow removal at locations prone to snow drifting. Cable barrier is not an obstruction to drifting snow.
- Analysis of potential reduction of sight distance due to barrier selection and placement.
- Additional widening and earthwork requirements. With some systems, such as concrete barrier and beam guardrail, the need for additional shoulder widening or slope flattening is common. Selection of these types of barriers may require substantial environmental permitting or roadway reconstruction. Permits issued under the SEPA and NEPA processes may lead to the use of a barrier design, such as cable barrier, which has fewer potential environmental impacts and costs.
- For concrete barrier systems:
  - Lower maintenance costs than for other barrier types.
  - Deterioration due to weather and vehicle impacts is less than most other barrier systems.
  - Unanchored precast concrete barrier can usually be realigned or repaired after a vehicle impact. However, heavy equipment may be necessary to reposition or



replace barrier segments. Therefore, in medians, consider the shoulder width and the traffic volume when determining the acceptability of unanchored precast concrete barrier versus rigid concrete barrier. See [Exhibit 1610-3](#) for deflection area requirements.

Consider the following for existing barrier systems:

- Install, replace, or modify transitions as discussed in [1610.04\(6\)](#) Transitions and Connections.
- When installing new terminals, extend the guardrail to meet the length-of-need criteria found in [1610.03\(5\)](#).
- When replacing damaged terminals, consider extending the guardrail to meet the length of need criteria in [1610.03\(5\)](#)
- When the end of a barrier has been terminated with a small mound of earth, remove and replace with a terminal as described in [1610.06\(3\)](#).
- Special use or aesthetic barriers may be used on designated Scenic Byway and Heritage Tour routes if funding, permits, and approvals can be arranged (see [1610.08](#)).
- Design Manual [Chapter 1120](#) identifies specific requirements to be addressed for a Preservation project. For other projects, address barrier runs that include:
  - W-beam guardrail with 12-foot 6-inch post spacing, or no blockouts, or both.
  - W-beam guardrail on concrete posts.
  - Cable barrier on wood or concrete posts.
  - Half-moon or C-shaped rail elements.

### **1610.03(1) Barrier Placement Considerations**

Proper installation of a barrier system is required for the system to perform similar to the crash tests that resulted in its acceptance for use on our highways. Maximize the distance between the barrier and the travelled way.

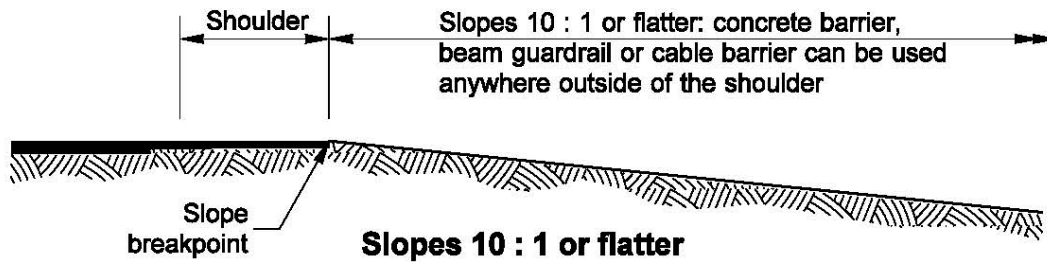
See [Chapter 1239](#) for minimum lateral clearance requirements.

#### **1610.03(1)(a) Placement on a Slope**

Slopes may affect barrier placement. Considerations for barrier placement on a slope include:

- For slopes that are 10:1 or flatter, concrete barrier, beam guardrail or cable barrier can be installed anywhere beyond the edge of shoulder. See [Exhibit 1610-2](#).
- For additional placement guidance see [1610.05\(1\)](#) for cable barrier, see [1610.04\(2\)](#) for beam guardrail, and see [1610.06](#) for concrete barrier.

## Exhibit 1610-2 Traffic Barrier Locations on Slopes



## 1610.03(1)(b) Placement in Median Locations

Considerations for barrier placement in a median include:

- Address the design deflection characteristics of the barrier to avoid placement of barrier where the design deflection extends into oncoming traffic.
- Narrow medians provide little space for any maintenance activities, including repair or repositioning of the barrier. Installing barriers in medians that provide less than 8 feet from the edge of the traveled way to the face of the barrier will likely require temporarily closing the adjacent lane during maintenance activities. This will impact the travelling public and impact maintenance staff, and maintenance staff should be consulted. See [Chapter 301](#) Design and Maintenance Coordination.
- At locations where the roadways are on independent alignments and there is a difference in elevation between the roadways, the slope from the upper roadway might be steeper than 6H:1V. In these locations, position the median barrier along the upper roadway and provide deflection and offset distance as discussed previously. Barrier is generally not needed along the lower roadway except where there are fixed features in the median.
- In wider medians, the selection and placement of barrier might depend on the slopes in the median. At locations where the median slopes are relatively flat (10H:1V or flatter), unrestrained precast concrete barrier, beam guardrail, and cable barrier can be used depending on the available deflection distance. At these locations, position the barrier as close to the center of the median as possible so that the recovery distance can be maximized for both directions. There may be a need to offset the barrier from the flow line to avoid impacts to the drainage flow.
- In general, cable barrier is recommended with medians that are 30 feet or wider. However, cable barrier may be appropriate for narrower medians if adequate deflection distance exists.
- When W-beam barrier is placed in a median as a countermeasure for cross-median crashes, design the barrier to be struck from either direction of travel. For example, the installation of beam guardrail might be double-sided (Type 31-DS).
- For additional placement guidance see [1610.05\(1\)](#) for cable barrier, see [1610.04\(2\)](#) for beam guardrail, and see [1610.06](#) for concrete barrier.

### **1610.03(2) Sight Distance**

When selecting and placing a barrier system, consider the possible impact the barrier type and height may have on sight distance. In some cases, barriers may restrict the sight distances of road users entering the roadway, such as from road approaches, intersections, and other locations. In these cases, the barrier may need to be adjusted to meet the sight distance requirements at these locations.

### **1610.03(3) Barrier Deflections**

Expect all barriers, except rigid barriers (such as concrete bridge rails, barrier integral to retaining walls, or embedded cast-in-place barriers), to deflect when hit by an errant vehicle. The amount of deflection is primarily dependent on the stiffness of the system. However, vehicle speed, angle of impact, and weight of the vehicle also affect the amount of barrier deflection. For flexible and semi-rigid roadside barriers, the deflection distance is designed to prevent the impacting vehicle from striking the object being shielded. For unrestrained rigid systems (unanchored precast concrete barrier), the deflection distance is designed to help prevent the barrier from being knocked over the side of a drop-off or steep fill slope (2H:1V or steeper).

In median installations, design systems such that the anticipated deflection will not enter the lane of opposing traffic. When evaluating new barrier installations, consider whether impacts would require significant traffic closures to accomplish maintenance. Use a rigid system where deflection cannot be accommodated, such as in narrow medians or at the edge of bridge decks or other vertical drop-off areas. Runs of rigid concrete barrier can be cast in place or extruded with appropriate footings.

In some locations, where deflection distance is limited, anchor precast concrete barrier. Unless the anchoring system has been designed to function as a fully rigid barrier, some movement can be expected and repairs may be more expensive. Use of an anchored or other deflecting barrier on top of a retaining wall without deflection distance provided requires approval from the HQ Design Office. See [1610.06](#) for more information on concrete barrier.

Refer to [Exhibit 1610-3](#) for barrier deflection design values when selecting a longitudinal barrier. The deflection values for cable and beam guardrail are minimum distances, measured between the face of the barrier to the fixed feature. The deflection values for unanchored concrete barrier are minimum distances, measured from the back edge of the barrier to the fixed feature, drop-off or slope break.

## Exhibit 1610-3 Longitudinal Barrier Deflection

Barrier Type	System Type	Deflection
High-tension cable barrier	Flexible	12 ft [1]
Beam guardrail, Types 1, 1a, 2, 10, and 31	Semi-rigid	3 ft (face of barrier to object)
Two-sided W-beam guardrail, Types 3, 4, and 31-DS	Semi-rigid	2 ft (nearest face of barrier to object)
Permanent concrete barrier, unanchored	Rigid Unrestrained	3 ft [2] (back of barrier to object)
Temporary concrete barrier, unanchored	Rigid Unrestrained	2 ft [3] (back of barrier to object)
Precast concrete barrier, anchored	Rigid Anchored	6 inches
Rigid concrete barrier	Rigid	No deflection
<b>Notes:</b> [1] See <a href="#">1610.05(2)</a> [2] When placed in front of a 2H:1V or flatter fill slope, the deflection distance can be reduced to 2 feet. [3] When used as temporary bridge rail, anchor all barrier within 3 feet of a drop-off.		

**1610.03(4) Flare Rate**

A roadside barrier is considered flared when it is not parallel to the edge of the traveled way.

Flare the ends of longitudinal barriers where site constraints allow (see [1610.01\(1\)](#)). The four functions of a flare are to:

- Maximize the distance between the barrier (and its terminal) and the travelled way.
- Reduce the length of need.
- Redirect an errant vehicle.
- Minimize a driver's reaction to the introduction of an object near the traveled way.

Keeping flare rates as flat as site constraints allow preserves the barrier's redirection performance and minimizes the angle of impact. It has also been shown that an object (or barrier) close to the traveled way might cause a driver to shift laterally, slow down, or both. The flare reduces this reaction by gradually introducing the barrier so the driver does not perceive the barrier as an object to be avoided. The flare rates in [Exhibit 1610-4](#) are intended to satisfy the four functions listed above. Flares that are more gradual may be used. Flare rates are offset parallel to the edge of the traveled way. Transition sections are not flared.

Situations exist where hardware installations may have barrier flare rates different than shown in [Exhibit 1610-4](#). If a *Standard Plan* for a barrier installation shows a different flare rate than is shown in [Exhibit 1610-4](#), the flare rate shown on the *Standard Plan* can be used.

## Exhibit 1610-4 Longitudinal Barrier Flare Rates

Posted Speed (mph)	Rigid & Rigid Anchored System	Unrestrained Rigid System	Semi-rigid
65–70	20:1	18:1	15:1
60	18:1	16:1	14:1
55	16:1	14:1	12:1
50	14:1	12:1	11:1
45	12:1	11:1	10:1
40 or below	11:1	10:1	9:1

**1610.03(5) Length of Need**

Length of need refers to the total length of longitudinal barrier needed to shield a fixed feature.

In many cases, there may be a portion of the traffic barrier installation that is not redirective in capability. For instance, if a run of concrete barrier is terminated with an impact attenuator, there will likely be a section of the impact attenuator that is not redirective (see [Chapter 1620](#) for more information). Therefore, in most cases, the Length of Need does not equal (i.e., it is shorter than) the actual physical length of the traffic barrier installation required to achieve that length of need.

Length of need is dependent on the location and geometrics of the object, direction(s) of traffic, posted speed, motor vehicle traffic volume, and type and location of traffic barrier.

When designing a barrier for a fill slope (see [Chapter 1600](#)), the length of need begins at the point where the need for barrier is recommended. For fixed objects and water, [Exhibit 1610-5](#) shows design parameters for determining the needed length of a barrier for both adjacent and opposing traffic on relatively straight sections of highway.

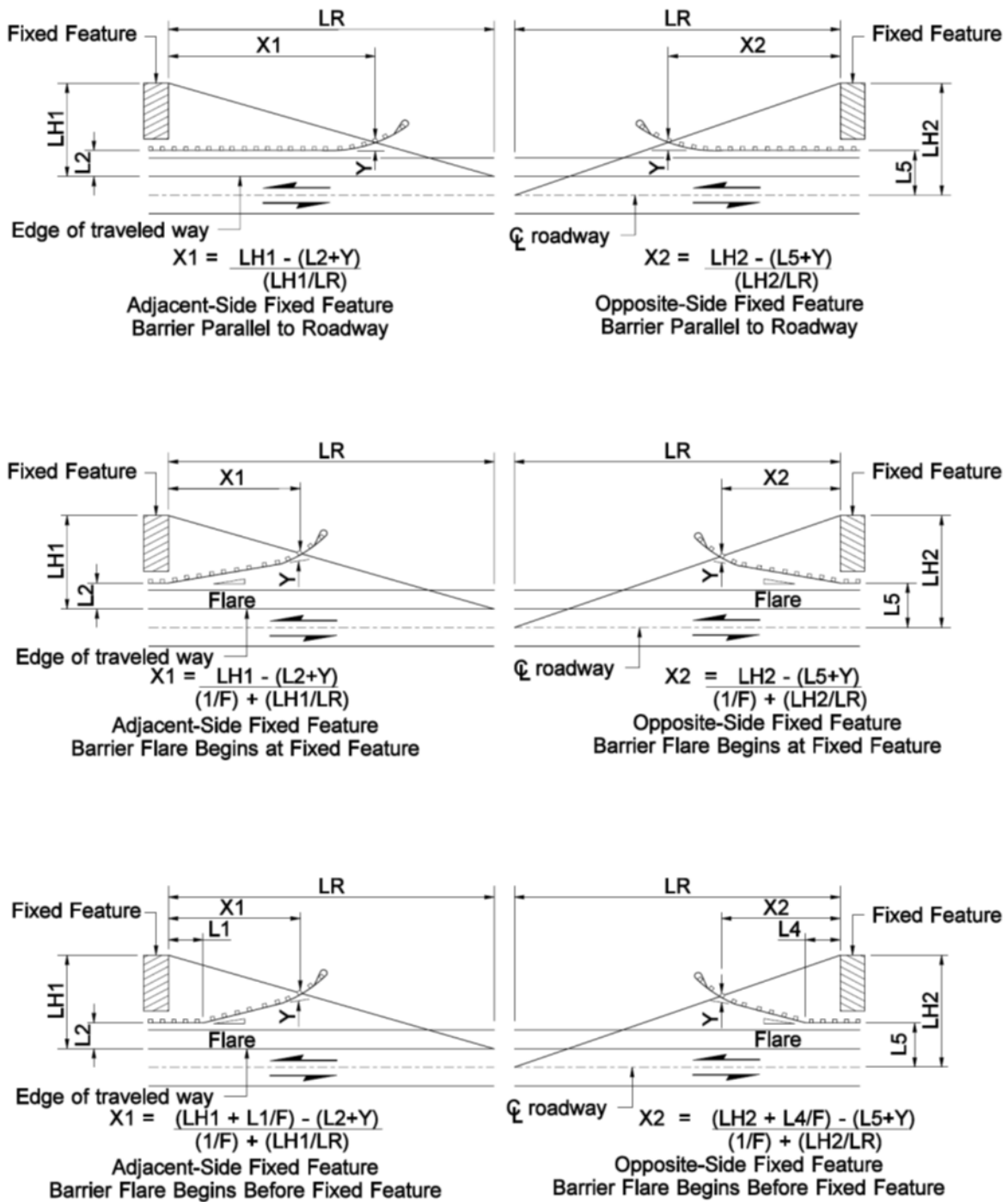
When barrier is to be installed on the outside of a horizontal curve, the length of need can be determined graphically as shown in [Exhibit 1610-7](#). For installations on the inside of a curve, determine the length of need as though it were straight. Also, consider the flare rate, barrier deflection, and barrier end treatment to be used.

When beam guardrail is placed in a median, consider the potential for impact from opposing traffic when conducting a length of need analysis. When guardrail is placed on either side of objects in the median, consider whether the trailing end of each run of guardrail will shield the leading end of the opposing guardrail. Shield the leading end when it is within the Design Clear Zone of opposing traffic (see [Exhibit 1610-8](#)). This is also a consideration when objects are placed in the outer separations between the main line and collector-distributors.

Before the actual length of need is determined, establish the lateral distance between the proposed barrier installation and the object shielded. Provide a distance that is greater than or equal to the anticipated deflection of the longitudinal barrier. (See [Exhibit 1610-3](#) for barrier deflections.) Place the barrier as far from the edge of the traveled way as possible while maintaining the deflection distance.

If the end of the length of need is near an adequate cut slope, extend the barrier and embed it in the slope (see [1610.04\(5\)](#)). Avoid gaps of 300 feet or less. Short gaps are acceptable when the barrier is terminated in a cut slope. If the end of the length of need is near the end of an existing barrier, it is recommended that the barriers be connected to form a continuous barrier. Consider maintenance access issues when determining whether or not to connect barriers.

Exhibit 1610-5 Barrier Length of Need on Tangent Sections



Note: For supporting length of need equation factors, see Exhibit 1610-6

## Exhibit 1610-6 Barrier Length of Need

Posted Speed (mph)	Design Parameters						
	ADT				Barrier Type		
	Over 10,000	5,000 to 10,00	1,000 to 4,999	Under 1,000	Rigid & Rigid Anchored Barrier	Rigid Unrestrained Barrier	Semi-rigid Barrier
	LR (ft)	LR (ft)	LR (ft)	LR (ft)	F	F	F
70	360	330	290	250	20	18	15
65	330	290	250	225	20	18	15
60	300	250	210	200	18	16	14
55	265	220	185	175	16	14	12
50	230	190	160	150	14	12	11
45	195	160	135	125	12	11	10
40	160	130	110	100	11	10	9
35	135	110	95	85	11	10	9
30	110	90	80	70	11	10	9
25	110	90	80	70	11	10	9

L1 = Length of barrier parallel to roadway from adjacent-side fixed feature to beginning of barrier flare. This is used if a portion of the barrier cannot be flared (such as a bridge rail and the transition).

L2 = Distance from adjacent edge of traveled way to portion of barrier parallel to roadway.

L4 = Length of barrier parallel to roadway from opposite-side fixed feature to beginning of barrier flare.

L5 = Distance from centerline of roadway to portion of barrier parallel to roadway. **Note:** If the fixed feature is outside the Design Clear Zone when measured from the centerline, it may only be necessary to provide a crash-tested end treatment for the barrier.

LH1 = Distance from outside edge of traveled way to back side of adjacent-side fixed feature. **Note:** If a fixed feature extends past the Design Clear Zone, the Design Clear Zone can be used as LH1.

LH2 = Distance from centerline of roadway to back side of opposite-side fixed feature. **Note:** If a fixed feature extends past the Design Clear Zone, the Design Clear Zone can be used as LH2.

LR = Runout length, measured parallel to roadway.

X1 = Length of need for barrier to shield an adjacent-side fixed feature.

X2 = Length of need for barrier to shield an opposite-side fixed feature.

F = Flare rate value.

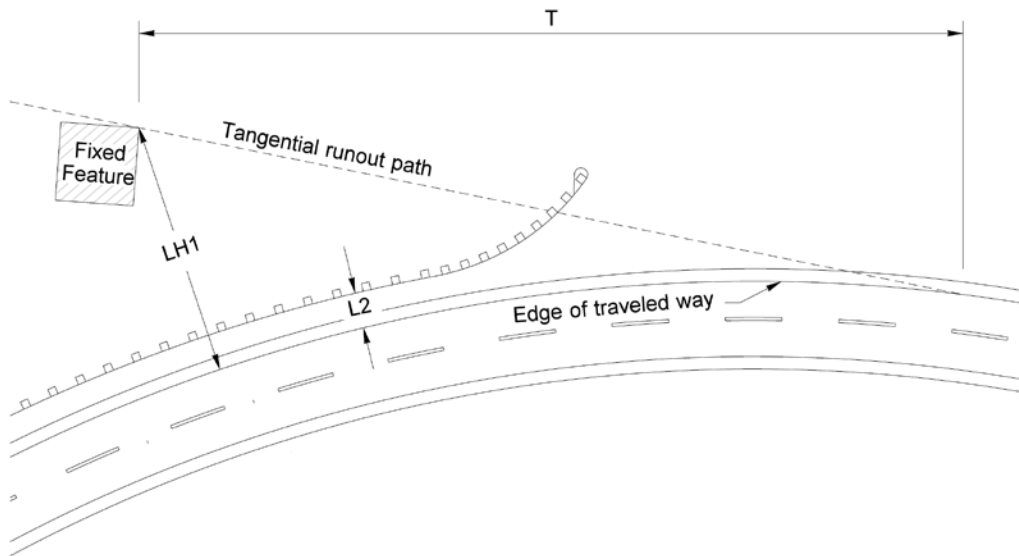
Y = Offset distance needed at the beginning of the length of need.

**Different end treatments need different offsets:**

- For the SRT 350 and FLEAT 350, use Y = 1.8 feet.
- For evaluating existing BCTs, use Y = 1.8 feet.
- For the FLEAT TL-2, use Y = 0.8 feet.
- No offset is needed for the non-flared terminals or impact attenuator systems. Use Y = 0.



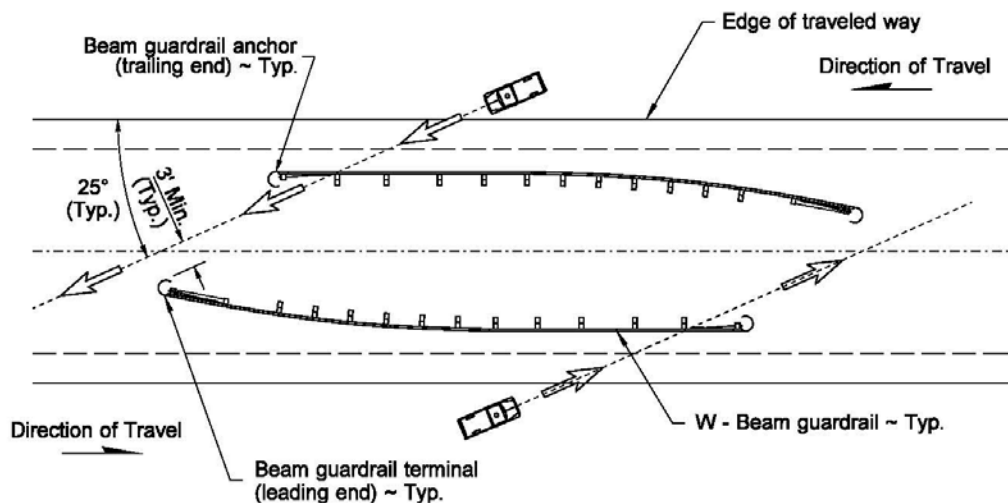
## Exhibit 1610-7 Barrier Length of Need on Curves



## Notes:

- This is a graphical method for determining the length of need for barrier on the outside of a curve.
- On a scale drawing, draw a tangent from the curve to the back of the fixed feature. Compare T to LR from [Exhibit 1610-6](#) and use the shorter value.
- If using LR, follow [Exhibits 1610-5](#) and [6](#).
- If using T, draw the intersecting barrier run to scale and measure the length of need.

## Exhibit 1610-8 W-Beam Guardrail Trailing End Placement for Divided Highways



### 1610.03(6) **Barrier Delineation**

Refer to [Chapter 1030](#) for barrier delineation requirements.

### 1610.04 **Beam Guardrail**

Strong post W-beam guardrail and three beam guardrail are semi-rigid barriers used predominantly on roadsides. They have limited application as median barrier. A strong-post W-beam (commonly referred to as W-Beam) guardrail system is the most common type of guardrail system used. The design uses wood or steel posts, rail, and blockouts to support the rail away from the post. The system resists a vehicle impact through a combination of the tensile and flexural stiffness of the rail and the bending or shearing resistance of the post.

Installed incorrectly, strong post W-beam guardrail can cause vehicle snagging or spearing. This can be avoided by lapping the rail splices in the direction of traffic (as shown in the [Standard Plans](#)), by using crash-tested end treatments, and by blocking the rail away from the posts.

Beam guardrail systems are shown in the [Standard Plans](#).

#### 1610.04(1) **Beam Guardrail Systems**

##### 1610.04(1)(a) **Type 31 Beam Guardrail**

Use Type 31 guardrail for new runs. The Type 31 system uses many of the same components as the old WSDOT Type 1 system. The main differences are that the blockouts extend 12 inches from the posts, the rail height is 31 inches from the ground to the top of the rail, and the rail elements are spliced between posts.

Type 31 guardrail offers tolerance for future HMA overlays. The system allows a 3-inch tolerance from 31 inches to 28 inches without adjustment of the rail element.

Type 31 guardrail is available double-sided, which can be used in medians.

##### 1610.04(1)(b) **(Old) Type 1 Beam Guardrail**

Previous WSDOT standard practice was to install W-beam guardrail at a rail height of 27 to 28 inches, and is referred to as "Type 1" guardrail. WSDOT is phasing out the use of Type 1 guardrail. Do not use Type 1 guardrail for new installations. For more information on (Old) Beam Guardrail Type 1, see: <http://www.wsdot.wa.gov/Design/Policy/RoadsideSafety.htm>.

Existing runs of Type 1 guardrail are acceptable to leave in place. If an existing run of Type 1 guardrail requires extending, use the Beam Guardrail Type 31 to Beam Guardrail Type 1 Adaptor shown in the [Standard Plans](#), and complete the guardrail extension using Type 31 guardrail.

##### 1610.04(1)(c) **Other Guardrail Types**

W-beam guardrail Type 2 and Type 3 have a height of 30 inches and utilize a rubrail. A rubrail is a structural steel channel added below the W-beam rail and is used in these specific designs to reduce vehicle snagging on the post. Existing runs of Type 2 or Type 3 guardrail are acceptable to leave in place. If the existing run of Type 2 or 3 requires extending contact WSDOT Design Office to identify appropriate extension methods.

Type 4 guardrail is a double-sided version of the Type 1 guardrail system. For new installation, use the Type 31 double-sided w-beam guardrail instead of Type 4 guardrail. Existing runs of Type 4 guardrail are acceptable to leave in place. If the existing run of Type 4 requires extending contact WSDOT Design Office to identify appropriate extension methods to transition to the Type 31 double-sided system.

Type 10 and Type 11 are three-beam guardrail systems. Existing runs of Type 10 or 11 guardrail are acceptable to leave in place. If an existing run of Type 10 or Type 11 guardrail requires extending, contact the WSDOT Design Office to discuss options.

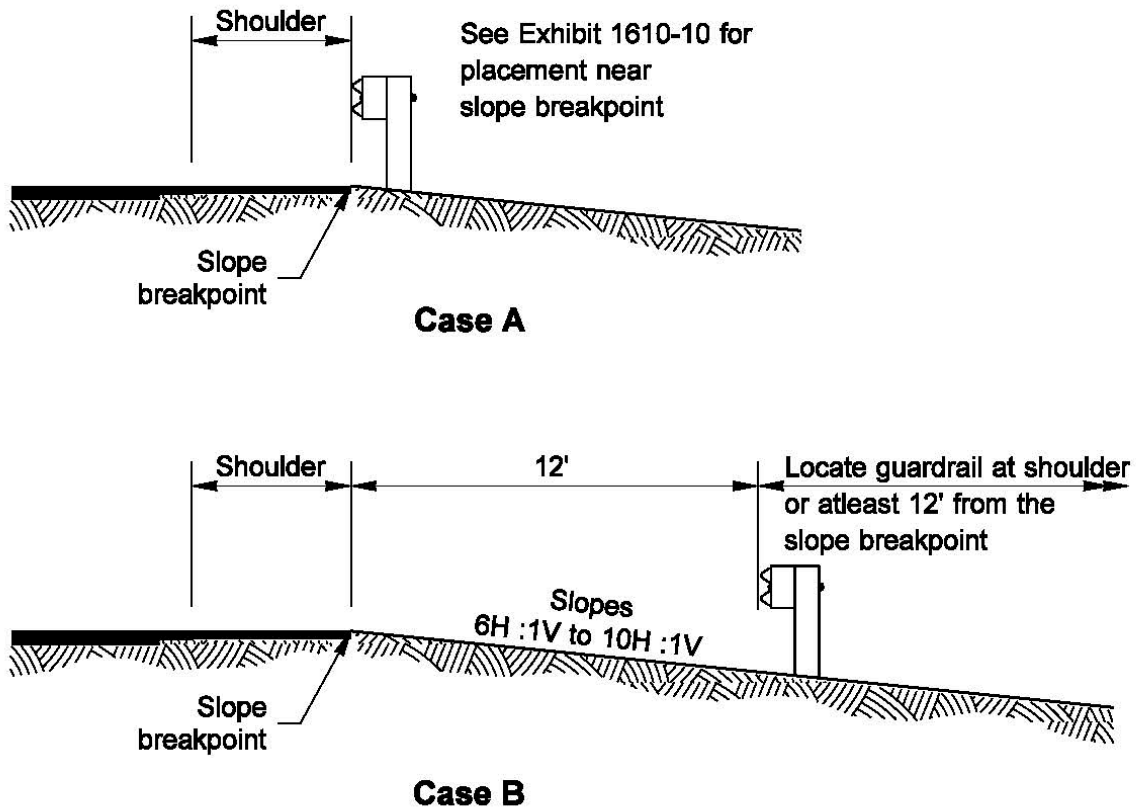
Weak post W-beam guardrail (Type 20) and three beam guardrail (Type 21) are flexible barrier systems primarily used in conjunction with a Service Level 1 bridge rail system for bridges with timber decks. These systems use weak steel posts. For information on Type 20 and Type 21 guardrail see: <http://www.wsdot.wa.gov/Design/Policy/RoadsideSafety.htm>

### 1610.04(2) **Beam Guardrail Placement**

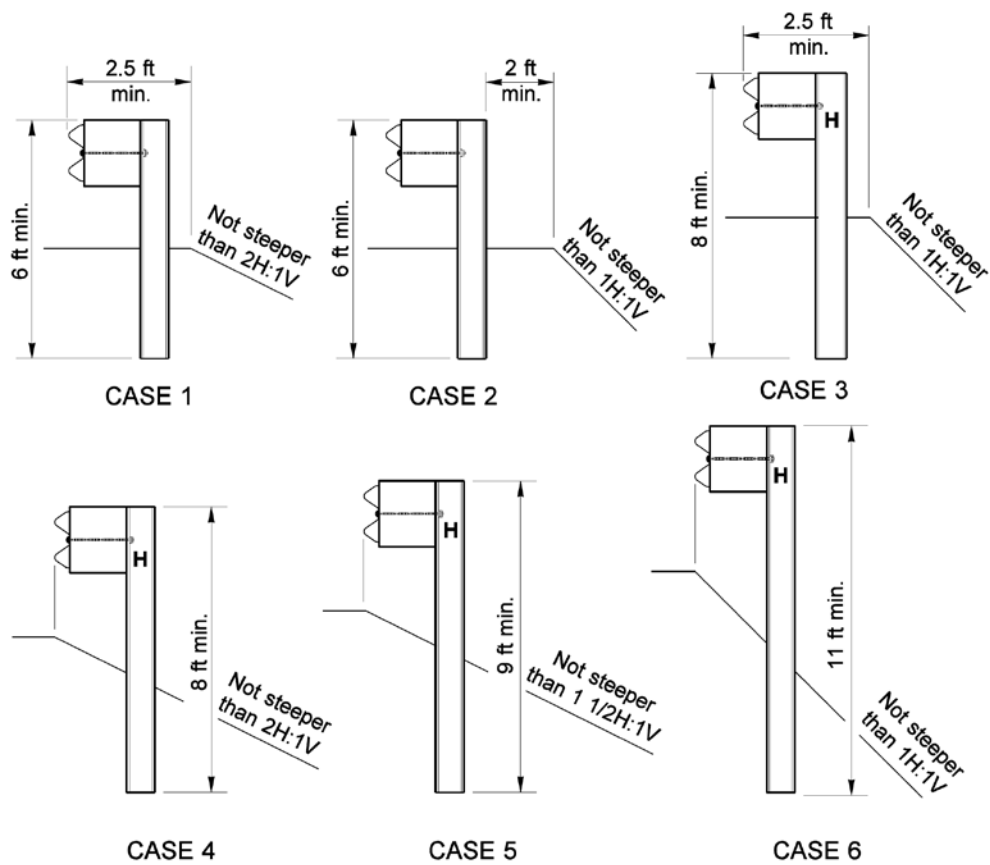
There are a number of considerations regarding guardrail placement. These include:

- During the project development processes, consult with maintenance staff to help identify guardrail runs that may need to be modified.
- When guardrail is installed along existing shoulders with a width greater than 4 feet, the shoulder width may be reduced by 4 inches to accommodate the 12-inch blockout. A Design Analysis is not required for the reduced shoulder width. If the remaining shoulder width is 4 feet or less, see [Chapter 1030](#) for barrier delineation guidance.
- Keep the slope of the area between the edge of the shoulder and the face of the guardrail 10H:1V or flatter.
- On fill slopes 10:1 or flatter, beam guardrail can be placed anywhere outside of the shoulder.
- On fill slopes between 6H:1V and 10H:1V, place beam guardrail at the shoulder or at least 12 feet from the slope breakpoint (as shown in [Exhibit 1610-9](#)).
- Do not place beam guardrail on a fill slope steeper than 6H:1V
- On the high side of superelevated sections, place beam guardrail at the edge of shoulder prior to the slope breakpoint.
- For W-beam guardrail installed at or near the shoulder, 2 feet of shoulder widening behind the barrier is generally provided from the back of the post to the slope breakpoint of a fill slope (see [Exhibit 1610-10](#), Case 2). If the slope is 2H:1V or flatter, this distance can be 2.5 feet measured from the face of the guardrail rather than the back of the post (see [Exhibit 1610-10](#), Case 1).
- On projects where no roadway widening is proposed and site constraints prevent providing the 2-foot shoulder widening behind the barrier, long post installations are available as shown in [Exhibit 1610-10](#), Cases 3, 4, 5, and 6. When installing guardrail where the roadway is to be widened or along new alignments, the use of Cases 5 and 6 requires a Design Analysis.

Exhibit 1610-9 Beam Guardrail Installation on 6:1 to 10:1 Slopes



## Exhibit 1610-10 Beam Guardrail Post Installation



Type 31 Shown

**Notes:**

- Use Cases 1 and 3 when there is a 2.5-foot or greater shoulder widening from face of guardrail to the slope breakpoint.
- Use Case 2 when there is a 4.0-foot or greater shoulder widening from the face of the guardrail to the slope breakpoint.
- Use Cases 4, 5, and 6 when there is less than a 2.5-foot shoulder widening from face of guardrail to the slope breakpoint.
- Cases shown do not apply to terminals, transition sections or anchors. Install terminals, transition sections and anchors per the [Standard Plans](#).

**1610.04(3) W-Beam Barrier Height**

For Pavement Preservation (P1) projects see [Chapter 1120](#).

For other projects with existing Type 1 guardrail runs under 26.5 inches, adjust or replace the rail to a height of 28 inches minimum to 30 inches maximum, or replace the run with the 31-inch high Type 31 beam guardrail.

If Type 1 Alternative W-beam guardrail is present, the rail element may be raised after each overlay. If Type 1 Alternative is not present, the blockout and rail element may be raised up to 4 inches. This requires field drilling a new hole in the guardrail post. See the [Standard Plans](#).

#### **1610.04(4) Additional Guidance**

Additional guidance related to w-beam guardrail:

- Locations where crossroads and driveways cause gaps in the guardrail create situations requiring special consideration. Elimination of the need for the barrier is the preferred solution. At these locations, a barrier flare might be needed to provide sight distance.
- Rail washers on beam guardrail are not normally used. If rail washers are present, removal is not necessary. However, if the rail element is removed for any reason, do not reinstall rail washers. In areas where heavy snow accumulations are expected to cause the bolts to pull out, specify snowload post washers and rail washers in the contract documents (snowload post washers are used to help prevent the bolts from pulling through the posts, and snowload rail washers are used to help prevent the bolt head from pulling through the rail). In other installations, it is normal to have the rail pull loose from the bolt head when impacted. Do not use rail washers within the limits of a guardrail terminal except, for some models, at the end post when they are needed for anchorage of the rail.
- The use of curb in conjunction with beam guardrail is discouraged. If a curb is needed, the 3 inch-high curb is preferred. If necessary, the 4-inch-high extruded curb can be used behind the face of rail for any posted speed. The 6-inch-high extruded curb can be used at locations where the posted speed is 50 mph or below. When replacing extruded curb at locations where the posted speed is above 50 mph, use 3 inch-high or 4-inch-high curb. (See the [Standard Plans](#) for extruded curb designs.)
- When curb is used in conjunction with Type 31 W-beam guardrail, an acceptable option is to place up to a 6-inch-high extruded curb at a maximum 6 inch offset in front of the face of the rail at any posted speed. Contact the WSDOT Design Office for more information.
- Guardrail posts are expected to be able to rotate when the rail is impacted. The installation of strong post W-beam guardrail posts in rigid surfacing such as asphalt or concrete pavement involves specially designed post holes that will allow the posts to rotate. Contact the WSDOT Design Office for more information.
- For (Old) Guardrail Types 1, 2, 3, and 4, it is acceptable to use blockouts that extend the rail element from the post for a distance not to exceed 16 inches.

#### **1610.04(5) Terminals and Anchors**

A guardrail anchor is required at the end of a run of guardrail to develop tensile strength throughout its length. In addition, when the end of the guardrail is subject to head-on impacts, a crash-tested guardrail terminal is required (see the [Standard Plans](#)).

Replace guardrail terminals that do not have a crash-tested design with crash-tested guardrail terminals. Common features of systems that do not meet current crash-tested designs include:

- No cable anchor.

- A cable anchored into concrete in front of the first post.
- Second post not breakaway (CRT).
- Design A end section.
- Design C end sections may be left in place if the terminal is otherwise a crash-tested design —see the [Standard Plans](#) for end section details.
- Terminals with beam guardrail on both sides of the posts (two-sided).
- Buried guardrail terminals that slope down such that the guardrail height is reduced to less than 28 inches (measured in relation to a 10H:1V line extended from the breakpoint at edge of shoulder).

When the height of a terminal, as measured from the ground to the top of the rail element, will be affected by the project, adjust the terminal based upon the following criteria:

- If the height of the adjoining Type 1, 2, 3, or 4 guardrail will be reduced to less than 26.5 inches or increased to greater than 30 inches, adjust the height of the terminal to a minimum of 28 inches and a maximum of 30 inches. A terminal height of 30 inches is desirable to accommodate future overlays.
- If the height of the adjoining Type 31 guardrail will be reduced to less than 28 inches or increased to greater than 32 inches, adjust the height of the terminal to 31 inches.

When adjusting terminals that are equipped with CRT posts, the top-drilled holes in the posts need to remain at the surface of the ground.

One terminal that was used extensively on Washington's highways was the Breakaway Cable Terminal (BCT). This system used a parabolic flare similar to the Slotted Rail Terminal (SRT) and a Type 1 anchor (Type 1 anchor posts are wood set in a steel tube or a concrete foundation). For guidance regarding BCT's on Preservation projects see [Chapter 1120](#). For non-Preservation projects replace BCTs with a currently approved terminal.

Information regarding (Old) Type 1 beam guardrail terminals can be found at:

🔗 <http://www.wsdot.wa.gov/Design/Policy/RoadsideSafety.htm>

#### **1610.04(5)(a) Buried Terminal (BT) for Type 31 Beam Guardrail**

A buried terminal is designed to terminate the guardrail by burying the end in a backslope. The BT is the preferred terminal because it eliminates the exposed end of the guardrail.

For new BT installations, use the Buried Terminal Type 2. Previously, another BT option (the Buried Terminal Type 1) was an available choice. For existing installations, it is acceptable to leave this option in service as long as height requirements and other design criteria is met. See the plan sheet at: 🔗 [www.wsdot.wa.gov/design/standards/plansheet](http://www.wsdot.wa.gov/design/standards/plansheet).

The BT uses a Type 2 anchor to develop the tensile strength in the guardrail. The backslope needed to install a BT is to be 3H:1V or steeper and at least 4 feet in height above the roadway. The entire BT can be used within the length of need for backslopes of 1H:1V or steeper if the barrier remains at full height in relation to the roadway shoulder to the point where the barrier enters the backslope.

For backslopes between 1H:1V and 3H:1V, design the length of need beginning at the point where the W-beam remains at full height in relation to the roadway shoulder—usually

beginning at the point where the barrier crosses the ditch line. If the backslope is flatter than 1H:1V, provide a minimum 20-foot-wide by 75-foot-long clear area that is free of fixed features behind the barrier and between the beginning length of need point at the terminal end to the mitigated object to be protected.

Flare the guardrail to the foreslope/backslope intersection using a flare rate that meets the criteria in [1610.03\(4\)](#). Provide a 4H:1V or flatter foreslope into the face of the guardrail and maintain the full guardrail height to the foreslope/backslope intersection in relation to a 10H:1V line extending from edge of shoulder breakpoint. (See the [Standard Plans](#) for details.)

#### **1610.04(5)(b) Non-flared Terminals for Type 31 Beam Guardrail**

If a buried terminal cannot be installed as described in [1610.04\(5\)\(a\)](#), install a non-flared terminal. These systems use W-beam guardrail with a special end piece that fits over the end of the guardrail. When hit head on, the end piece is pushed over the rail, absorbing the energy of the impacting vehicle in the process. An anchor is included for developing the tensile strength of the guardrail. The length of need does not begin at the impact head, but will vary by system. Non-flared terminals may be provided for two different design levels that are based on the posted speed of the highway. For highways with a posted speed of 50 mph or above, use only a TL-3 (Test Level 3) product. For highways with a posted speed of 45 mph or below, either a TL-2 or a TL-3 product is acceptable. See the [Standard Plans](#).

The availability and acceptance of these systems is expected to change rapidly over time. Refer to the Type 31 Beam Guardrail Terminals website for the latest information on availability or acceptance of different systems (see

<http://www.wsdot.wa.gov/Design/Policy/RoadsideSafety.htm>).

Although non-flared terminals do not need to have an offset at the end, a flare is recommended so that the end piece does not protrude into the shoulder. See the [Standard Plans](#).

Four feet of additional widening behind the terminal is needed at the end posts to properly anchor the systems (See the [Standard Plans](#)). When widening includes an embankment, properly placed and compacted fill material will be necessary for optimum terminal performance (see the [Standard Specifications](#) for embankment widening for guardrail).

For guardrail runs that are located more than 12 feet from the slope break (as shown in [Exhibit 1610-9](#)) no additional embankment widening is required at the terminal.

No snowload rail washers are allowed within the limits of these terminals.

WSDOT does not currently use a flared terminal system for the Type 31 guardrail system.

**Note:** Approved shop drawings for terminals can be found by accessing the following website:

<http://www.wsdot.wa.gov/Design/Policy/RoadsideSafety.htm>

#### **1610.04(5)(c) Terminal Evolution Considerations**

Some currently approved terminals have been in service for a number of years. During this time, there have been minor design changes. However, these minor changes have not changed the devices' approval status. Previous designs for these terminals may remain in place.

**Note:** If questions arise concerning the current approval status of a device, contact the HQ Design Office for clarification when replacement is being considered.



### 1610.04(5)(d) Anchors

A guardrail anchor is needed at the end of a run of guardrail to develop tensile strength throughout its length.

- Use the Type 10 anchor to develop the tensile strength of the guardrail on the end of Type 31 guardrail runs where a crash-tested terminal is not needed.
- A Type 2 anchor is used with the buried terminal.

For information on anchor types used in runs of (Old) Beam Guardrail Type 1, see:

<http://www.wsdot.wa.gov/Design/Policy/RoadsideSafety.htm>.

### 1610.04(6) Transitions and Connections

When there is an abrupt change from one barrier type to a more rigid barrier type, a vehicle hitting the more flexible barrier may be caught in the deflected barrier pocket and directed into the more rigid barrier. This is commonly referred to as “pocketing.” A transition stiffens the more flexible barrier by decreasing the post spacing, increasing the post size, and using stiffer beam elements to reduce the possibility of pocketing.

When connecting beam guardrail to a more rigid barrier or a structure use the transitions and connections that are shown in [Exhibits 1610-12](#) and [1610-13](#) and detailed in the [Standard Plans](#).

Type 21 transitions can be used on highways with all posted speeds to connect w-beam guardrail to single slope, safety shape or vertical concrete barriers.

Type 22 and Type 23 transitions are used to connect w-beam guardrail to thrie beam on bridges.

Type 24 transitions can be used on highways with a posted speed of 45 mph or less to connect w-beam guardrail to single slope, safety shape or vertical concrete barriers.

When connecting a Type 21 or Type 24 Transition to an existing vertical faced bridge rail with a low parapet, a special connection plate may be required. Coordinate with the WSDOT Bridge and Structures Office (BSO). The transition pay item includes the connection.

For information regarding transitions used with (Old) Type 1 guardrail see:

<http://www.wsdot.wa.gov/Design/Policy/RoadsideSafety.htm>.

Exhibit 1610-11 Vacant**Exhibit 1610-12 Guardrail Connections**

Condition	Connection
Unrestrained concrete barrier	A
Rigid, rigid anchored, untapered safety shape bridge rails or barriers [1]	B
Bridge rails with curbs 9 inches or less in width	B
Bridge rails with curbs between 9 and 18 inches wide	C
Vertical walls, single slope, or tapered safety shape barrier [1]	D
<p><b>Note:</b></p> <p>[1] New single slope and safety shape bridge rails are designed with the toe of the barrier tapered so that it does not project past the face of the approach guardrail.</p>	

## Exhibit 1610-13 Transitions and Connections

Connecting Type 31 W-Beam Guardrail to:		Transition Type*	Connection	
Bridge Rail <sup>[1]</sup>	New Installation	21, 24 <sup>[3]</sup>	D	
	Existing Concrete	Concrete Parapet > (Greater Than) 20 in.	21, 24 <sup>[3]</sup> <a href="#">Exh. 1610-12</a> <sup>[2]</sup>	
		Concrete Parapet < (Less Than) 20 in.	21, 24 <sup>[3]</sup> <a href="#">Exh. 1610-12</a> <sup>[2]</sup>	
	Thrie Beam at Face of Curb	Approach End	23	n/a
		Trailing End (two-way traffic only)	23	n/a
	Thrie Beam at Bridge Rail (curb exposed)	Approach End	22	n/a
Trailing End (two-way traffic only)		22	n/a	
Concrete Barrier	Rigid & Rigid Anchored	21, 24 <sup>[3]</sup>	<a href="#">Exhibit 1610-12</a>	
	Unrestrained	21, 24 <sup>[3]</sup>	A	
Rigid Structures such as Bridge Piers	See Placement Cases 11A-31 through 11C-31	21, 24 <sup>[3]</sup>	n/a	
Connecting Thrie Beam Guardrail to:		Transition Type*	Connection	
Bridge Rail or Concrete Barrier	See the thrie beam transition in the <a href="#">Plan Sheet Library</a>		<a href="#">Exhibit 1610-12</a>	

\*Consult Section C of the [Standard Plans](#) for details on transition types.

**Notes:**

- [1] For Service Level 1 bridge rail, see: <http://www.wsdot.wa.gov/Design/Policy/RoadsideSafety.htm>, Type 1 Beam Guardrail Placement Cases, Placement Case 14.
- [2] When connecting a Type 21 or Type 24 Transition to an existing vertical faced bridge rail with a low parapet, a special connection plate may be required. Contact the WSDOT BSO for details.
- [3] Transition Type 21 is acceptable for use on highways with all posted speeds. Transition Type 24 is acceptable for use on highways with posted speeds 45 mph or below.

## 1610.04(7) Guardrail Placement Cases

The *Standard Plans* contain placement cases that show beam guardrail elements needed for typical situations. For new installations, use the appropriate Type 31 placement option.

Information regarding placement cases for (Old) Type 1 beam guardrail can be found at <http://www.wsdot.wa.gov/Design/Policy/RoadsideSafety.htm>.

### 1610.04(7)(a) Beam Guardrail Type 31 Placements

- Case 1-31 is used where there is one-way traffic. It uses a crash-tested terminal on the approach end and a Type 10 anchor on the trailing end.
- Case 2-31 is used where there is two-way traffic. A crash-tested terminal is used on both ends.
- Case 3-31 is used at railroad signal supports on one-way or two-way roadways. A terminal is used on the approach end, but usually cannot be used on the trailing end because of its proximity to the railroad tracks. If there is a history of crossover collisions, consider additional protection such as an impact attenuator.
- Case 4-31 is used where guardrail on the approach to a bridge is to be shifted laterally to connect with the bridge rail. A terminal is used on the approach end and a transition is needed at the bridge end. Curves (bends) are shown in the guardrail to shift it to the bridge rail. However, the length of the curves are not critical. The criterion is to provide smooth curves that are not more abrupt than the allowable flare rate (see Exhibit 1610-4).
- Case 5-31 is a typical bridge approach where a terminal and a transition are needed.
- Case 10 (A-31, B-31, and C-31) is used at roadside fixed features (such as bridge piers) when 3 or more feet are available from the face of the guardrail to the feature. The approach end is the same for one-way or two-way traffic. Case 10A-31 is used with two-way traffic; therefore, a terminal is needed on the trailing end. Case 10B-31 is used for one-way traffic when there is no need to extend guardrail past the bridge pier and a Type 10 anchor is used to end the guardrail. Case 10C-31 is used for one-way traffic when the guardrail will extend for a distance past the bridge pier.
- Case 11 (A-31, B-31, and C-31) is used at roadside fixed features (such as bridge piers) when the guardrail is to be placed within 3 feet of the feature. Since there is no room for deflection, the rail in front of the feature is to be considered a rigid system and a transition is needed. The trailing end cases are the same as described for Case 10.
- Beam Guardrail Type 31 (12'6", 18'9", or 25' Span) is used when it is necessary to omit one, two, or three posts. This application is typically used when guardrail is installed over a shallow buried obstruction, such as drainage structures. This design may be used in other situations where there are no above ground objects located behind the guardrail and within the lateral deflection distance. Three CRT posts are provided on each end of the omitted post(s).
- Guardrail Placement Strong Post – Type 31 is the “Strong Post Intersection Design for Type 31 barrier” that provides a more rigid barrier. This design is used at crossroads or road approaches where a barrier is needed and where the length of need cannot be achieved using standard components such as standard longitudinal barrier runs, transitions, and terminals.

## 1610.05 High-Tension Cable Barrier

Cable barrier is a flexible barrier system that can be used on a roadside or as a median barrier. Early cable barrier designs centered around low-tension cable systems. With research and crash analysis of these systems, the designs evolved into high-tension cable systems. These high-tension cable systems are primarily used in medians and are preferred for many installations due in part to high benefit-to-cost ratios. Read about advantages for selecting a cable barrier system here:

🔗 <http://www.wsdot.wa.gov/publications/fulltext/design/Policy/CableBarriers.pdf>.

There are a number of manufacturers of high-tension cable barrier systems. These systems have been designed using either three or four-cables fixed to metal posts placed at a fixed spacing. Each cable system has specially designed anchors placed at both ends of the barrier run to provide the proper tensioning in the cables. Currently, both three and four-cable high-tension cable barrier systems are installed along WSDOT state routes. See additional information about these approved cable barrier systems here:

🔗 <http://www.wsdot.wa.gov/publications/fulltext/design/Policy/CableBarriers.pdf>.

Use four-cable high-tension cable barrier systems for all new installations.

### 1610.05(1) High-Tension Cable Barrier Placement

High-tension cable barrier can be placed in a median or along the roadside.

**Note:** Additional placement cases are shown in the WSDOT *Standard Plans*. For non-typical installations, such as double runs of cable barrier or median ditch cross sections that differ significantly from those shown, contact the HQ Design Office for guidance.

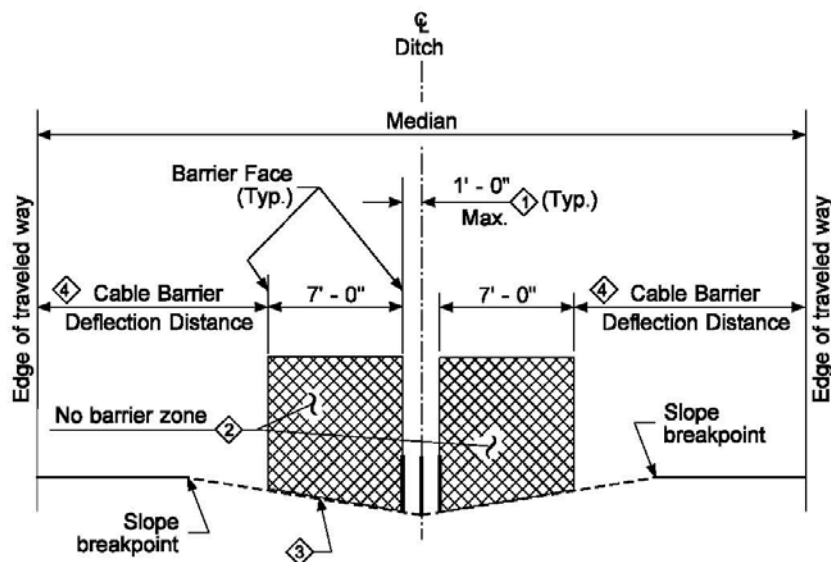
#### 1610.05(1)(a) Median Applications

For typical cable barrier installations in a median, the following apply (see [Exhibit 1610-14a](#)):

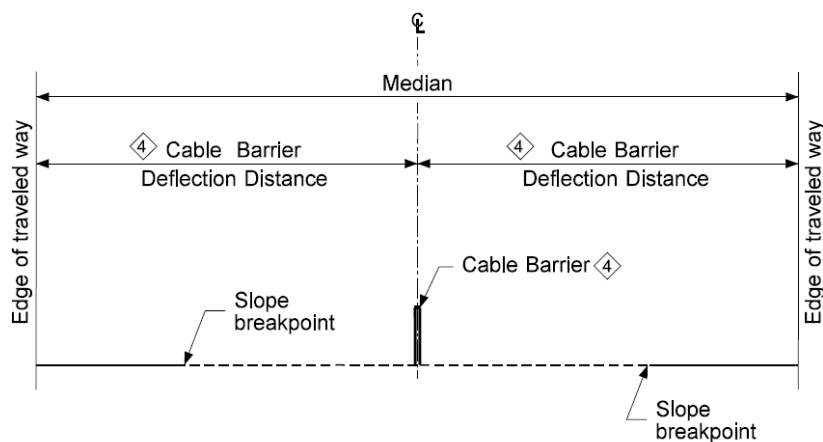
- Install the cable barrier as far from the edge of traveled way as site constraints allow. Consider a minimum placement distance of 8 feet from the edge of traveled way to allow vehicles to use this area for refuge.
- Install cable barrier on slopes 6H:1V or flatter.
- There are approved high-tension cable barrier systems that can be placed on slopes as steep as 4H:1V. The use of these systems requires special placement considerations, contact the HQ Design Office for guidance.
- Provide an obstruction free zone within the cable barrier system's lateral deflection distance (see [1610.05\(2\)](#)).
- On tangent sections of a roadway where no ditch is present, consider installing the cable barrier in the middle of the median.
- Along horizontal curves, consider installing the cable barrier along the inside of the curve. Reduce the post spacing per manufacturer's recommendations.
- Where a ditch is present, install cable barrier at the centerline of the ditch or within 1-foot of the ditch centerline.

- Avoid installing cable barrier within the range between 1-foot to 8-foot offset from the ditch centerline to avoid “under-riding” of vehicles that cross the ditch (see [Exhibit 1610-14a](#)).
- In some situations, it may be advantageous to terminate a run of cable barrier on one side of the median (to provide maintenance access to a feature, for example) and then begin an adjacent cable barrier run on the opposite side of the median. In this application, it is important to provide adequate cable barrier overlap distance between the two runs. For placement guidance, see [Exhibit 1610-15](#).
- Narrow medians provide little space for maintenance crews to repair or reposition the barrier. Wherever site conditions permit, provide at least 14 feet of clearance from the adjacent lane edge to the face of the cable barrier.

## Exhibit 1610-14a Median Cable Barrier Placement



Cable Barrier Placement in Median with Ditch



Cable Barrier Placement in Median with No Ditch

## Notes:

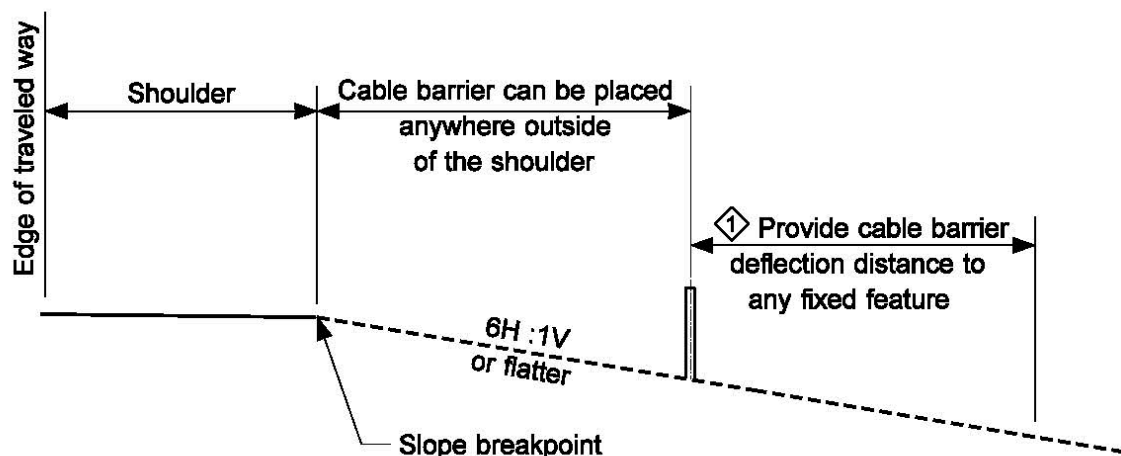
- ① Cable barrier may be installed in the center of the ditch and from the ditch centerline a maximum of 1 foot (left or right).
- ② Avoid installing cable barrier within a range of 1-foot to 8-foot offset from the ditch centerline.
- ③ Applies to slopes 6H:1V or flatter.
- ④ Provide an obstruction free zone within the cable barrier's lateral deflection distance, see 1610.05(2)

### 1610.05(1)(b) Roadside Applications

For typical non-median roadside applications, the following apply (see Exhibit 1610-14b):

- Install the cable barrier as far from the edge of traveled way as site constraints allow.
- Consider a minimum placement distance of 8 feet from the edge of traveled way to allow vehicles to use this area for refuge.
- Install cable barrier on slopes 6H:1V or flatter
- There are approved high-tension cable barrier systems that can be placed on slopes as steep as 4H:1V. The use of these systems requires special placement considerations, contact the HQ Design Office for guidance.
- Along horizontal curves, consider installing along the inside of the curve. Reduce post spacing per manufacturer's recommendations
- Provide an obstruction free zone within the cable barrier system's lateral deflection distance, see 1610.05(2).

**Exhibit 1610-14b Roadside Cable Barrier Placement**



**Notes:**

- 1 Provide an obstruction free zone within the cable barrier's lateral deflection distance, see 1610.05(2)

### 1610.05(2) High-Tension Cable Barrier Lateral Deflection Distances

Depending on the high-tension cable barrier system, lateral deflection distances for each barrier system vary based upon the length of the barrier run, the spacing of the end anchors, and post spacing. Provide an obstruction free zone within the system's lateral deflection distance for the following situations:

1. In the direction of travel (located in the median or along roadside), locate the cable barrier system so that there are no fixed objects within the limits of the cable barrier lateral deflection distance.



2. For opposing traffic (where present), locate the cable barrier to provide lateral deflection distance to prevent a vehicle's encroachment into the opposite lane of travel.

Provide a minimum 12-feet for cable barrier lateral deflection distance and specify the minimum allowable lateral deflection distance in the contract documents in order for the contractor to select a cable barrier manufacturer that can meet the lateral deflection requirements.

**Note:** There are new high-tension cable barrier systems under development that may change selection and placement criteria. For example, newer systems may allow placement on steeper slopes or have reduced deflection distances. Contact the HQ Design Office for guidance.

### **1610.05(3) High-Tension Cable Barrier Height**

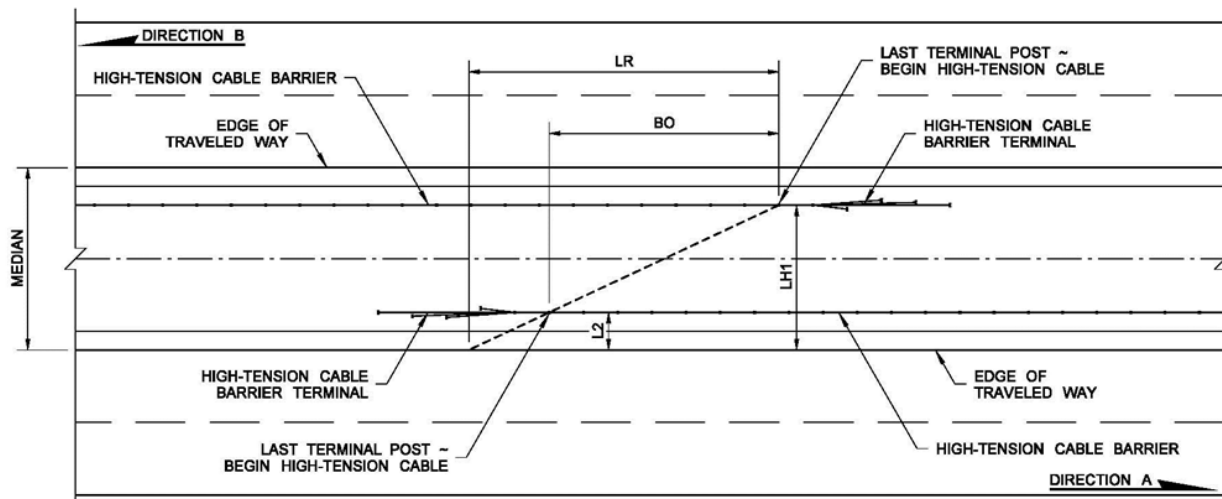
A high-tension four-cable barrier system shall provide a height to the center of the top cable of not less than 35 inches and a height to the center of the bottom cable not greater than 19 inches. Previous testing of cable barrier systems has shown that providing cables within the ranges specified typically restrains a vehicle traversing the various slopes and reduces the possibility of the vehicle either overriding or under riding the cable barrier.

### **1610.05(4) High-Tension Cable Barrier Termination**

Manufacturers of high-tension four-cable barrier systems provide designed anchors for the ends of cable barrier runs. Other alternatives to end a cable barrier include:

- It is possible to terminate high-tension cable barrier systems by connecting directly to beam guardrail runs (such as transitions to bridge rails) or to a separate cable barrier anchorage system. Review field conditions, check local maintenance personnel needs, and then specify the required connection option in the contract documents. If a separate anchorage system is used, refer to [Exhibit 1610-15](#) for placement guidance.
- When cable barrier is connected to a more rigid barrier, a transition section is typically needed. Contact the HQ Design Office for further details.

Exhibit 1610-15 Cable Barrier Placement for Divided Highways

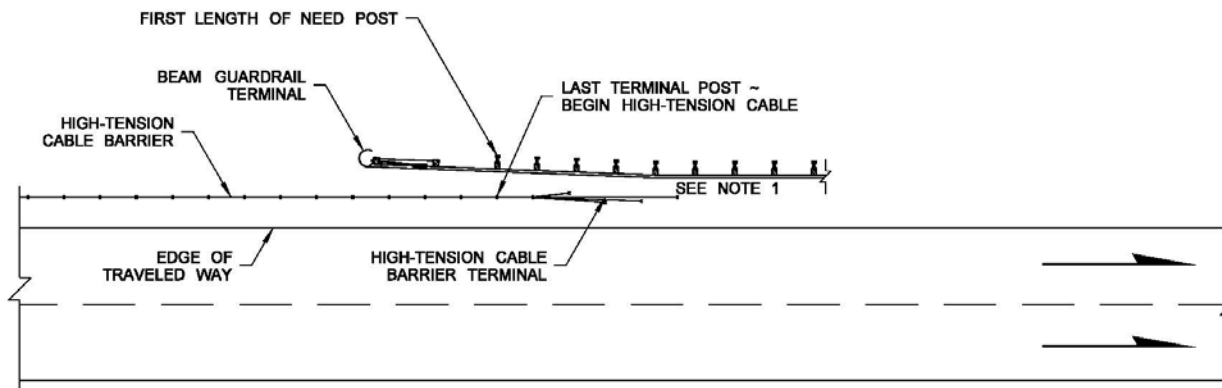


Cable Barrier Median Overlap

$$BO = \frac{LH1 - L2}{(LH1/LR)} \quad (\text{Direction A shown})$$

Note:

Calculate barrier overlap (BO) from both directions of travel. Use the greatest value of BO obtained.



Cable Barrier Overlap with Beam Guardrails

Notes:

- The beam guardrail may need to be extended and flared to maintain adequate barrier overlap and shoulder width.
- Typical applications may be at either bridge transitions or where high-tension cable and beam guardrail systems end or begin.
- For supporting length of need equation factors, see [Exhibit 1610-6](#).

### 1610.05(5) High-Tension Cable Barrier Curb Placement

Avoid the placement of curb in conjunction with high-tension cable barrier systems. Currently, there are no known acceptable cable barrier systems that have been successfully crash tested with this feature present.

### 1610.06 Concrete Barrier

Concrete barriers are identified as either rigid, rigid anchored, or unrestrained rigid systems. They are commonly used in medians and as shoulder barriers. These systems are stiffer than beam guardrail or cable barrier, and impacts with these barriers tend to be more severe. Consider the following when installing concrete barriers:

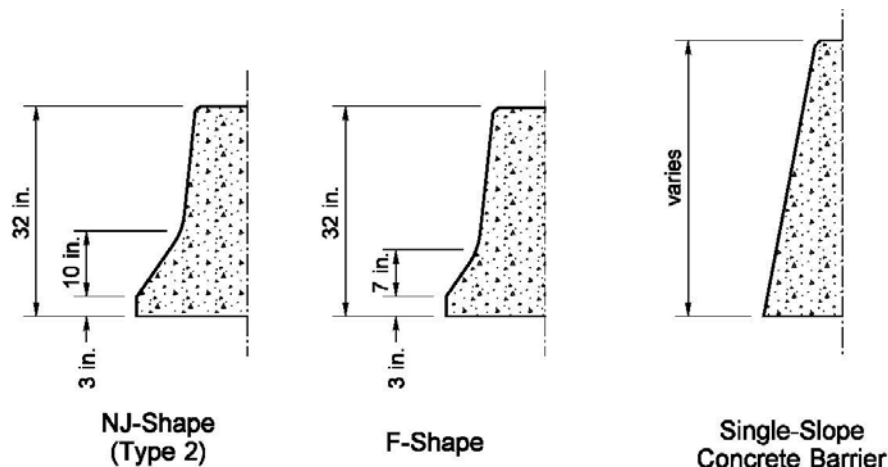
- For slopes 10H:1V or flatter, concrete barrier can be used anywhere outside of the shoulder.
- Do not use concrete barrier at locations where the foreslope into the face of the barrier is steeper than 10H:1V.
- Light standards mounted on top of precast concrete median barrier must not have breakaway features. (See the concrete barrier light standard section in the [Standard Plans](#).)
- When considering concrete barrier use in areas where drainage and environmental issues (such as stormwater, wildlife, or endangered species) might be adversely impacted, contact the HQ Hydraulics Office and/or the appropriate environmental offices for guidance. Also, refer to [1610.02](#).

#### 1610.06(1) Concrete Barrier Shapes

Concrete barriers use a single-slope or safety shape (New Jersey or F-Shape) to redirect vehicles while minimizing vehicle vaulting, rolling, and snagging. A comparison of these barrier shapes is shown in [Exhibit 1610-16](#).

The single-slope barrier face is the recommended option for embedded rigid concrete barrier applications.

**Exhibit 1610-16 Concrete Barrier Shapes**



When the single-slope or F-Shape face is used on structures, and precast barrier is selected for use on the approaches, a cast-in-place transition section is needed so that no vertical edges of the barrier are exposed to oncoming traffic. For details on bridge rail designs, see the [Bridge Design Manual](#).

For aesthetic reasons, avoid changes in the shape of the barrier face within a project or corridor.

The New Jersey shape and F-shape barriers are commonly referred to as “safety shapes.” The New Jersey shape and F-shape have an initial overall height of 32 inches. This height includes provision for up to a 3-inch future pavement overlay that can reduce the barrier height to 29 inches minimum.

As part of the implementation of MASH-compliant hardware WSDOT is transitioning from predominantly using New Jersey shape barrier (Type 2 barrier) for precast concrete barrier to using F-shape concrete barrier (Type F barrier) instead. For permanent installations of non-embedded precast concrete barrier F-shape (Type F) barrier is preferred. New Jersey shape (Type 2) barrier is still allowed.

For projects requiring variations of Type F barrier with no Standard Plan yet available, using Type 2 barrier instead is appropriate, or contact the HQ Design Office for more information.

To learn more about WSDOT’s plan for implementing MASH-compliant hardware see the following website: <http://www.wsdot.wa.gov/Design/Policy/RoadsideSafety.htm>

#### 1610.06(1)(a) Safety Shape Barrier

Concrete Barrier Type F (see the [Standard Plans](#)) is a freestanding precast barrier that has the F-shape on both sides. It can be used for both median and shoulder installations. Unanchored units are connected with steel pins through metal loops. For permanent installation, this barrier is placed on a paved surface and a paved surface is provided beyond the barrier for deflection. See [Exhibit 1610-3](#) for deflection requirements.

The New Jersey shape face is primarily used on precast concrete barrier. Concrete Barrier Type 2 (see the [Standard Plans](#)) is a freestanding precast barrier that has the New Jersey shape on two sides. It can be used for both median and shoulder installations. Unanchored units are connected with steel pins through wire rope loops. For permanent installation, this barrier is placed on a paved surface and a paved surface is provided beyond the back of barrier for deflection. See [Exhibit 1610-3](#) for deflection requirements.

The cost of precast safety shape barrier is significantly less than the cost of the cast-in-place barriers. Therefore, consider the length of the barrier run and the deflection needs to determine whether transitioning to precast barrier is desirable. If precast safety shape barrier is used for the majority of a project, use the safety shape for small sections that need cast-in-place barrier, such as for a light standard section, see the [Standard Plans](#) for additional details for transitioning the barrier faces.

Concrete barrier Type 4 is a precast, single-faced New Jersey shape barrier. These units are not freestanding and are to be placed against a rigid structure or anchored to the pavement. If Type 4 barriers are used back to back, fill any gap between them to prevent tipping.

Precast barrier can be anchored where a more rigid barrier is needed. (Anchoring methods are shown in the [Standard Plans](#).) Anchors Type 1 and Type 2 are for temporary installations on a rigid pavement. Type 3 anchors can be used in temporary or permanent installations on an

asphalt pavement. Consult the WSDOT BSO for details when anchoring permanent precast concrete barrier to a rigid (Portland cement concrete) pavement.

Precast barrier used on the approach to bridge rail is to be connected to the bridge rail by installing loops embedded into the bridge rail with epoxy resin and as detailed in the [Standard Plans](#).

Place unrestrained (unanchored) precast concrete barrier on slopes of 5% (20H:1V) or flatter where possible. The maximum slope for placement of concrete barrier is 10% (10H:1V).

In the past WSDOT used a Type 5 single-faced New Jersey shape for special applications, such as adjacent to bridge rails with similar shapes. The Type 5 barrier is seldom used by WSDOT. See the Plan Sheet Library for more information on Type 5 barrier:

<http://www.wsdot.wa.gov/Design/Standards/PlanSheet/TB-5.htm>.

### 1610.06(1)(b) Single-Slope Barrier

Single-slope barrier is available in various heights, as shown in the [Standard Plans](#). Single-slope concrete barrier can be cast in place or precast. A primary benefit of using precast single-slope barrier is that it can be used as temporary barrier during construction and then reset into a permanent location. In temporary applications, the height of the single-slope barrier may also offer the added benefits of reducing headlight glare and providing reduced deflection characteristics over some other barrier types.

Single-slope barrier is considered a rigid system regardless of the construction method used provided the barrier is embedded a minimum of 3-inches in the roadway wearing surface on both sides. When precast single-slope barrier is installed on top of the roadway surface, it is considered a rigid unrestrained system and barrier deflection needs to be provided as shown in [Exhibit 1610-3](#).

For new installations, the minimum height of single-slope barrier above the roadway is 2 feet 10 inches, which allows a 2-inch tolerance for future overlays. The minimum total height of the barrier section is 3 feet 6 inches (including embedment). This allows for use of the 3-foot-6-inch barrier between roadways with grade separations of up to 5 inches. A grade separation of up to 10 inches is allowed when using a 4-foot-6-inch high barrier section, as shown in the [Standard Plans](#). The barrier is to have a depth of embedment equal to or greater than the grade separation. Contact the WSDOT BSO for grade separations greater than 10 inches.

### 1610.06(1)(c) High-Performance Concrete Barrier

High-Performance Concrete Barrier (HP Barrier) is a rigid barrier with a minimum height of 3-foot-6-inch above the roadway surface. This barrier is designed to function more effectively during heavy-vehicle crashes. This taller barrier may also offer the added benefits of reducing headlight glare and reducing noise in surrounding environments. WSDOT HP Barrier utilizes the single-slope shape. (See the [Standard Plans](#) for barrier details.)

Use HP Barrier in freeway medians of 22 feet or less. Also, use HP Barrier on Interstate or freeway routes where crash history suggests a need or where roadway geometrics increase the possibility of larger trucks hitting the barrier at a high angle (for example, on-ramps for freeway-to-freeway connections with sharp curvature in the alignment).

Consider the use of HP Barrier at other locations such as highways with narrow medians, near highly sensitive environmental areas, near densely populated areas, over or near mass transit facilities, or on vertically divided highways.

#### **1610.06(1)(d) Low-Profile Barrier**

Low-profile barrier designs are available for median applications where the posted speed is 45 mph or below. These barriers are normally used in urban areas. They are typically 18 to 20 inches high and offer sight distance benefits. For barrier designs, terminals, and further details, contact the HQ Design Office.

#### **1610.06(2) Concrete Barrier Height**

Overlays in front of safety shape concrete barriers can extend to the top of the lower, near-vertical face of the barrier before adjustment is necessary.

- Allow no less than 2-foot 5 inches from the pavement to the top of the safety shape barriers. Allow no less than 2-foot 8-inches from the pavement to the top of the single-slope barrier.

#### **1610.06(3) Concrete Barrier Terminals**

Whenever possible, bury the blunt end of a concrete barrier run into the backslope of the roadway. If the end of a concrete barrier run cannot be buried in a backslope or terminated as described below, terminate the barrier using a guardrail terminal and transition or an impact attenuator (see [Chapter 1620](#)).

To bury the blunt end of the barrier into a backslope, the following conditions must be met:

- The backslope is 3H:1V or steeper
- The backslope extends minimum of 4 feet in height above the edge of shoulder
- Flare the concrete barrier into the backslope using a flare rate that meets the criteria in [1610.03\(4\)](#)
- Provide a 10H:1V or flatter foreslope into the face of the barrier and maintain the full barrier height until the barrier intersects with the backslope. This might create the need to fill ditches and install culverts in front of the barrier face.

The 7-foot-long precast concrete barrier Type 2 and the 10- to 12-foot single-slope barrier terminal (precast or cast-in-place) may be used for the following conditions:

- Outside the Design Clear Zone.
- On the trailing end of the barrier when it is outside the Design Clear Zone for opposing traffic.
- On the trailing end of one-way traffic.
- Where the posted speed is 25 mph or below.

See the [Standard Plans](#) for barrier terminal details.

## 1610.07 Bridge Traffic Barriers

Bridge traffic barriers redirect errant vehicles and help to keep them from going over the side of the structure. (See the [Bridge Design Manual](#) for information regarding bridge barrier on new bridges and replacement bridge barrier on existing bridges).

When considering work on a bridge traffic barrier consult the WSDOT Bridge and Structures Office (BSO).

- The standard bridge traffic barrier is a 3 foot 6 inch single slope or F Shape traffic barrier.
- For corridor continuity, a 2 foot 10 inch single slope or 2 foot 8 inch F Shape traffic barrier may be used with a pedestrian railing attached to the top for a total height of 3 foot 6 inch height inches. This also meets requirements for worker fall protection.

Approach barriers, transitions, and connections are usually needed on all four corners of bridges carrying two-way traffic and on both corners of the approach end for one-way traffic. (See [1610.04\(6\)](#) for guidance on transitions). A transition is available to connect the Type 2 concrete barrier (New Jersey shape) and the bridge barrier (F-Shape.) (See the [Standard Plans](#) for further details).

Bridge railing attaches to the top of the bridge barrier. When bridge barrier is included in a project, the bridge rails, including crossroad bridge rail, are to be addressed. Consult the WSDOT BSO regarding bridge rail selection and design and for design of the connection to an existing bridge. Consider the following:

- Use an approved, NCHRP 350 or MASH crash-tested bridge traffic barrier on new bridges or bridges to be widened. The [Bridge Design Manual](#) provides examples of typical bridge rails. The BSO's minimum crash test level for all state and interstate bridges is a TL-4.
- An existing bridge rail on a roadway with a posted speed of 30 mph or below may remain in place if it is not located on a bridge over a National Highway System (NHS) highway. When Type 7 bridge rail is present on a bridge over an NHS highway with a posted speed of 30 mph or below, it may remain in place regardless of the type of metal rail installed. Other bridge rails are to be evaluated for strength and geometrics. (See [1610.07\(1\)](#) for guidance on retrofit techniques.)
- The Type 7 bridge rail is common. Type 7 bridge rails have a curb, a vertical-face parapet, and an aluminum top rail. The curb width and the type of aluminum top rail are factors in determining the adequacy of the Type 7 bridge rail, as shown in [Exhibit 1610-17](#). Consult the WSDOT BSO for assistance in evaluating other bridge rails.

When considering an overlay on a bridge, consult the WSDOT BSO to verify the overlay depth can be placed on the bridge deck based on the type of traffic barrier. There may be instances where the height of the bridge barrier will not allow for the planned overlay depth without removal of existing pavement.

Exhibit 1610-17 Type 7 Bridge Rail Upgrade Criteria

Aluminum Rail Type	Curb Width	
	9 Inches or Less	Greater Than 9 Inches*
Type R, S, or SB	Bridge rail adequate	Bridge rail adequate
Type 1B or 1A	Bridge rail adequate	Upgrade bridge rail
Other	Consult the WSDOT BSO	

\*When the curb width is greater than 9 inches, the aluminum be able to withstand a 5 kip load.

**1610.07(1) Bridge Barrier Retrofit**

If the bridge barrier system does not meet the criteria for strength and geometrics, modifications to improve its redirectional characteristics and its strength may be needed. Consult the WSDOT BSO to determine which retrofit method described below can be completed.

**1610.07(1)(a) Concrete Safety Shape**

Consult the WSDOT BSO to determine whether the existing bridge deck and other superstructure elements are of sufficient strength to accommodate this bridge barrier system and provide design details for the retrofit. Retrofitting with a new concrete bridge barrier is costly and requires authorization from Program Management when no widening is proposed.

**1610.07(1)(b) Thrie Beam Retrofit**

Retrofitting the bridge barrier with thrie beam is an economical way to improve the strength and redirectional performance of a bridge barrier. The thrie beam can be mounted to steel posts or the existing bridge barrier, depending on the structural adequacy of the bridge deck, the existing bridge barrier type, the width of curb (if any), and the curb-to-curb roadway width carried across the structure. [Exhibit 1610-18](#) shows typical retrofit criteria.

Note that bridges designated as historical landmarks may not be candidates for thrie beam retrofitting. Contact the Environmental Services Office regarding bridge historical landmark status.

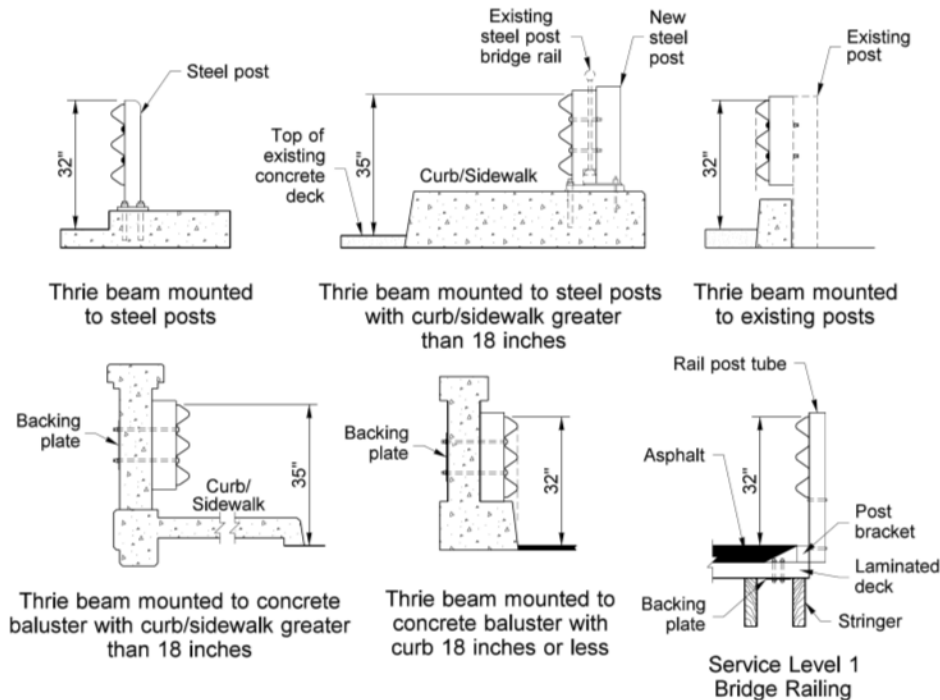
Consider the Service Level 1 (SL-1) system on bridges with wooden decks and for bridges with concrete decks that do not have the needed strength to accommodate the thrie beam system. Contact the WSDOT BSO for information needed for the design of the SL-1 system.



If a thrie beam retrofit results in reduction in sidewalk width ensure ADA compliance is addressed, see [Chapter 1510](#).

**Exhibit 1610-18 Thrie Beam Rail Retrofit Criteria**

Curb Width	Bridge Width	Concrete Bridge Deck		Wood Bridge Deck or Low-Strength Concrete Deck
		Concrete Bridge Rail (existing)	Steel or Wood Post Bridge Rail (existing)	
<18 inches		Thrie beam mounted to existing bridge rail <sup>[2]</sup> and blocked out to the face of curb. Height = 32 inches.	Thrie beam mounted to steel posts <sup>[2]</sup> at the face of curb. Height = 32 inches	<ul style="list-style-type: none"> <li>• Service Level 1 Bridge Rail. <sup>[2]</sup></li> <li>• Height = 32 inches.</li> <li>• Curb or wheel guard needs to be removed.</li> </ul>
>18 inches	> 28 ft (curb to curb)	Thrie beam mounted to steel posts <sup>[2]</sup> at the face of curb. <sup>[1]</sup> Height = 32 inches.		
>18 inches	< 28 ft (curb to curb)	Thrie beam mounted to existing bridge rail. <sup>[2]</sup> Height = 35 inches.	Thrie beam mounted to steel posts <sup>[2]</sup> in line with existing rail. Height = 35 inches.	



**Notes:**

- [1] To maximize available curb/sidewalk width for pedestrian use, thrie beam may be mounted to the bridge rail at a height of 35 inches.
- [2] Contact the WSDOT BSO for design details on bridge rail retrofit projects.

## 1610.08 Other Barriers

### 1610.08(1) *Redirectional Landform*

Redirectional landforms, also referred to as earth berms, were formerly installed to help mitigate crashes with fixed objects located in depressed medians and at roadsides. They were constructed of materials that provided support for a traversing vehicle. With slopes in the range of 2H:1V to 3H:1V, they were intended to redirect errant vehicles. The use of redirectional landforms has been discontinued. Where redirectional landforms currently exist as mitigation for a fixed object, provide alternative means of mitigation of the fixed object, such as remove, relocate, upgrade with crash-tested systems, or shield with barrier. Landforms may be used to provide a smooth surface at the base of a rock cut slope.

### 1610.08(2) *Aesthetic Barrier Treatment*

When designing a barrier for use on a Scenic Byway, consider barriers that are consistent with the recommendations in the associated corridor management plan (if one is available). Contact the region or HQ Landscape Architect Office to determine whether the project is on such a designated route. Low-cost options may be feasible, such as weathering agents, stains, colorants, or coatings applied to galvanized steel beam guardrail and its components. Higher-cost options, such as steel-backed timber rail and stone guardwalls, might necessitate a partnering effort to fund the additional costs. Grants might be available for this purpose if the need is identified early in the project definition phase.

### 1610.08(3) *Steel-Backed Timber Guardrail*

Steel-backed timber guardrails consist of a timber rail with a steel plate attached to the back to increase its tensile strength. There are several variations of this system that have passed crash tests. The nonproprietary systems use a beam with a rectangular cross section that is supported by either wood or steel posts.

A proprietary (patented) system, called the Ironwood Guardrail, is also available. This system uses a beam with a round cross section and is supported by steel posts with a wood covering to give the appearance of an all-wood system from the roadway. The incorporation of the Ironwood Guardrail will need to be documented. Consult with the Assistant State Design Engineer to determine what justification (proprietary or a public interest finding) will be required.

The most desirable method of terminating the steel-backed timber guardrail is to bury the end in a backslope, as described in [1610.04\(5\)](#). When this type of terminal is not possible, use of the barrier is limited to highways with a posted speed of 45 mph or below. On these lower-speed highways, the barriers can be flared away from the traveled way as described in [1610.03\(4\)](#) and terminated in a berm outside the Design Clear Zone.

For details on these systems, contact the HQ Design Office.

### 1610.08(4) *Stone Guardwalls*

Stone guardwalls function like rigid concrete barriers but have the appearance of natural stone. These walls can be constructed of stone masonry over a reinforced concrete core wall or of simulated stone concrete. These types of barriers are designed to have a limited textured

projection of the stones to help aid in the redirection characteristics of the barrier. The most desirable method of terminating this barrier is to bury the end in a backslope, as described in [1610.06\(3\)](#). When this type of terminal is not possible, use of the barrier is limited to highways with a posted speed of 45 mph or below. On these lower-speed highways, the barrier can be flared away from the traveled way and terminated in a berm outside the Design Clear Zone.

For details on these systems, contact the HQ Design Office.

### **1610.08(5) Dragnet**

The Dragnet Vehicle Arresting Barrier consists of chain link or fiber net that is attached to energy absorbing units. When a vehicle hits the system, the Dragnet brings the vehicle to a controlled stop with limited damage. Possible uses for this device include the following:

- Reversible lane entrances and exits
- Railroad crossings
- Truck escape ramps (instead of arrester beds—see [Chapter 1270](#))
- T-intersections
- Work zones
- Swing span bridges

Coordinate with the HQ Design Office for design details.

## **1610.09 References**

### **1610.09(1) Design Guidance**

WSDOT Roadside Safety site: <http://www.wsdot.wa.gov/Design/Policy/RoadsideSafety.htm>

[Bridge Design Manual LRFD](#), M 23-50, WSDOT

[Roadside Design Guide](#), AASHTO, 2011 with Errata (July 2015)

[Standard Plans for Road, Bridge, and Municipal Construction](#) (Standard Plans), M 21-01, WSDOT

[Traffic Manual](#), M 51-02, WSDOT

### **1610.09(2) Supporting Information**

[Manual for Assessing Safety Hardware \(MASH\)](#), AASHTO, 2009

[NCHRP 350](#), TRB, 1993

[Determining Length of Need](#). This e-learning course for WSDOT employees covers the “Length of Need,” which is a calculation of how much longitudinal barrier is necessary to shield objects on the roadside. Request this training via the web-based Learning Management System.



- 1620.01 General
- 1620.02 Design Criteria
- 1620.03 Selection Considerations
- 1620.04 Transportable Attenuators (Truck-Mounted and Trailer-Mounted)
- 1620.05 Older Systems
- 1620.06 Inertial Barrier Systems (Sand Barrels)

## 1620.01 General

Impact attenuator systems are protective systems that help aid an errant vehicle from impacting an object by either gradually decelerating the vehicle to a stop when hit head-on or by redirecting it away from the feature when struck on the side. These systems are used for rigid objects or other features that cannot be removed, relocated, or made breakaway.

Approved systems shall meet standardized testing defined in National Cooperative Highway Research Program (NCHRP) Report 350 or the American Association of State Highway and Transportation Officials (AASHTO) *Manual for Assessing Safety Hardware (MASH)*. In addition, these devices shall have an acceptance letter from FHWA that certifies that the device meets the appropriate crash test criteria and is eligible for federal-aid reimbursement.

## 1620.02 Design Criteria

The following design criteria apply to new, existing, or reset permanent and temporary impact attenuators.

Impact attenuators are placed so that they do not present a feature that requires mitigating in relation to opposing traffic. For median and reversible lane locations, the backup structure or attenuator-to-object connection is designed to help in aiding opposing traffic from being snagged.

Avoid placement of curbs between attenuators and traffic. Refer to the specific attenuator manufacturer's instructions if considering placement of curbing between an attenuator and the travelled way. It is desirable that existing curbing be removed and the surface smoothed with asphalt or cement concrete pavement before an impact attenuator is installed. However, mountable curbs 4 inches or less in height may be retained depending on the feasibility of removal and as long as the manufacturer's installation requirements are met.

In general, attenuators are aligned parallel to the roadway.

Consult with the Area Maintenance Superintendent who will be maintaining the system prior to selecting the attenuator systems to include in a construction contract.

### 1620.03 Selection Considerations

WSDOT classifies impact attenuators as **permanent** (for final installations that will remain in place) or **temporary** (for systems that will be in place during work zone traffic control operations and then removed). Some impact attenuator systems can be used in **both** a temporary capacity and then in a final/permanent installation.

For approved systems to choose from, see the WSDOT Impact Attenuator Design page at [http://www.wsdot.wa.gov/publications/fulltext/design/ProductFolder/PENDING\\_Impact\\_Attenuator\\_Design.docx](http://www.wsdot.wa.gov/publications/fulltext/design/ProductFolder/PENDING_Impact_Attenuator_Design.docx).

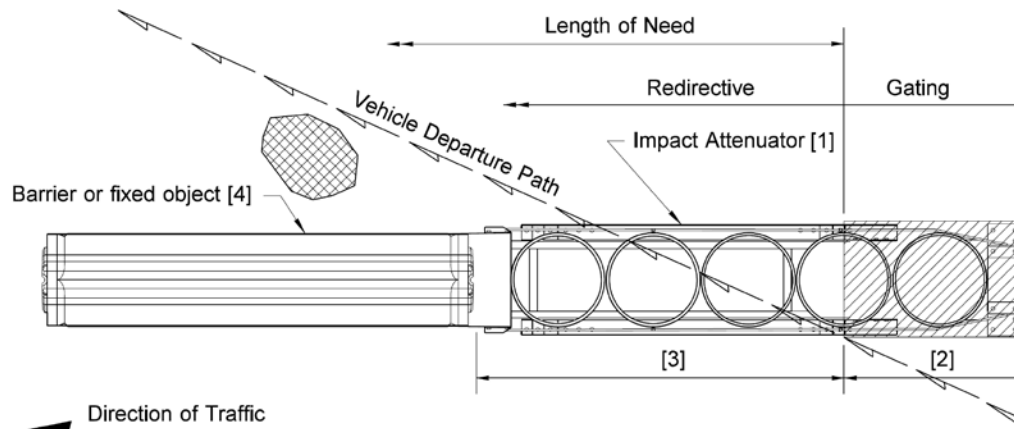
It is very important to consider that each application is unique when selecting impact attenuators for use in particular applications. This applies to both permanent and temporary installations.

To select an appropriate impact attenuator system, the following factors must be assessed:

- Posted speed
- Operating speed
- Average daily traffic (ADT)
- Repair crew exposure
- Proximity to the roadway
- Anticipated number of yearly impacts
- Available space (length and width)
- Lifecycle Maintenance costs
- Initial cost
- Duration (permanent or temporary use)
- Portion of the impact attenuator that is redirective/nonredirective (see [Exhibit 1620-1](#))
- Width of object to be shielded

It is important for designers to take into account the portion of an impact attenuator that is designed to redirect vehicles during a side impact of the unit. It is important that fixed objects, either permanent or temporary (such as construction equipment), are not located behind the nonredirective portion of these devices (see [Exhibit 1620-1](#)).

Exhibit 1620-1 Impact Attenuator Distance Beyond Length of Need

**Notes:**

- [1] Impact attenuator type and manufacturer varies with application. See the Attenuator Selection Template at: [http://www.wsdot.wa.gov/publications/fulltext/design/ProductFolder/Impact\\_attenuator\\_selection\\_template.xlsx](http://www.wsdot.wa.gov/publications/fulltext/design/ProductFolder/Impact_attenuator_selection_template.xlsx)
- [2] Distance beyond the length of need. This portion is nonredirective (gating).
- [3] This portion is redirective (nongating) and can be included as part of the barrier needed to satisfy length of need.
- [4] Concrete barrier shown for illustration purposes only. Type of object varies.

Select the system and configuration appropriate for the posted speed. In the interest of a cost-effective design, selecting a system applicable for the posted speed is recommended (although using a system tested for a higher speed is acceptable). Note that attenuators used on highways with posted speeds of 70 mph have additional considerations discussed below. Where there is evidence that the average operating speed of the facility is higher than the posted speed, consider selecting an attenuator system rated at the facility's operating speed.

Manufacturer's product information may indicate that a different system is required for speeds of 70 mph or greater. These models are generally referred to as "high speed" or "70 mph" systems. Use of these systems on facilities with 70 mph posted speeds is not required, and selection of a system rated for at least 60 mph will typically be appropriate for most sites on these facilities. For permanent installations where unusual conditions warrant consideration of a high-speed device, these systems are available and may be used with justification. Contact the HQ Design Office for guidance when considering one of these systems.

For information regarding spatial requirements and initial cost information related to impact attenuator systems, see the Attenuator Selection Template at:

[http://www.wsdot.wa.gov/publications/fulltext/design/ProductFolder/Impact\\_attenuator\\_selection\\_template.xlsx](http://www.wsdot.wa.gov/publications/fulltext/design/ProductFolder/Impact_attenuator_selection_template.xlsx).

When considering maintenance costs, anticipate the average annual impact rate. If few impacts are anticipated, lower-cost devices might meet the need. (See [Chapter 301](#) for examples of how to determine lifecycle costs for proposed hardware). Attenuators with the lowest initial cost and

initial site preparation will have high maintenance costs after each impact. Labor and equipment are needed to clean up the debris and install a new attenuator, as the lowest cost attenuators are typically destroyed after a single impact. Attenuators with higher initial installation cost typically have lower maintenance costs.

In selecting a system, one consideration is the anticipated exposure to traffic that the workers making the repairs may encounter. In areas with high traffic exposure, a low-maintenance system that can be repaired quickly is most desirable. Some systems need nearly total replacement or replacement of critical components (such as cartridges or braking mechanisms) after a head-on impact, while others simply need to be reset.

When a transition to connect with a concrete barrier, fixed object, or beam guardrail is needed, the transition type and connection may need to be specified (see the impact attenuator descriptions accessible through the Attenuator Selection Template at:

[http://www.wsdot.wa.gov/publications/fulltext/design/ProductFolder/Impact\\_attenuator\\_selection\\_template.xlsx](http://www.wsdot.wa.gov/publications/fulltext/design/ProductFolder/Impact_attenuator_selection_template.xlsx)).

In most cases, the transition type and connection required will be a custom design per the manufacturer (these transitions are included in the cost of the impact attenuator). In a few cases, the transition type and connection to use will be as described in [Chapter 1610](#) and the *Standard Plans* (these transition sections are not included in the cost of the impact attenuator and must be included as a separate bid item in the construction contract).

Consult with the Area Maintenance Superintendent who will be maintaining the systems before finalizing the list of attenuators to be included in the contract.

### **1620.03(1) Low-Maintenance Category**

Low maintenance devices have a higher initial cost, requiring substantial site preparation, including a backup or anchor wall in some cases, and cable anchorage at the front of the installation. However, repair costs are very low, with labor typically being the main expense. Maintenance might not be needed after minor side impacts with these systems.

Installation of a low-maintenance device is desirable at locations that meet at least one of the following criteria:

- Sites with an ADT of 25,000 or greater
- Sites with a history/anticipation of more than one impact-per year
- Sites with unusually challenging conditions, such as limitations on repair time, a likelihood of frequent night repairs, or narrow gore locations

Document the decision in the DDP to use any device other than a low-maintenance device at locations meeting at least one of the criteria above.

The HQ Design Office conducts a periodic review of maintenance records to consider which devices should be included in the Low-Maintenance category. For a description of requirements that need to be met in order to be included in the Low-Maintenance category, see:

[www.wsdot.wa.gov/publications/fulltext/design/roadsidesafety/low\\_maint.pdf](http://www.wsdot.wa.gov/publications/fulltext/design/roadsidesafety/low_maint.pdf)

### **1620.03(2) Documenting Attenuator Selection**

As the factors discussed previously are analyzed, identify inappropriate systems and eliminate them from further consideration. List the systems that are not eliminated in the contract. When



the site conditions vary, it might be necessary to have more than one list of acceptable systems within a contract. Systems are not to be eliminated without documented reasons. Also, wording such as “or equivalent” is not to be used when specifying these systems. If only one system is found to be appropriate, then approval from the Assistant State Design Engineer of a public interest finding for the use of a sole source proprietary item is needed.

Document attenuator selection using the Attenuator Selection Template that can be found at:  
[http://www.wsdot.wa.gov/publications/fulltext/design/ProductFolder/Impact\\_attenuator\\_selection\\_template.xlsx](http://www.wsdot.wa.gov/publications/fulltext/design/ProductFolder/Impact_attenuator_selection_template.xlsx)

### **1620.04 Transportable Attenuators (Truck-Mounted and Trailer-Mounted)**

Truck Mounted Attenuators and Trailer-Mounted Attenuators are portable systems mounted on trucks or trailers. They are intended for use in work zones and for temporary applications.

### **1620.05 Older Systems**

Many older systems are in use on Washington State highways and may be left in place or reset with concurrence of the WSDOT Area Maintenance Superintendent who maintains the system. New installations of these systems are not allowed.

For a list of older systems see:

[http://www.wsdot.wa.gov/publications/fulltext/design/ProductFolder/PENDING\\_Impact\\_Attenuator\\_Design.docx](http://www.wsdot.wa.gov/publications/fulltext/design/ProductFolder/PENDING_Impact_Attenuator_Design.docx).

### **1620.06 Inertial Barrier Systems (Sand Barrels)**

WSDOT is phasing out the use of inertial barrel systems (sand barrels) for new installations. Existing installations may be left in place. Situations may exist where inertial barrier systems are the only option. For information regarding the design of inertial barrier systems contact HQ Design Office.



- 1720.01 General
- 1720.02 Definitions
- 1720.03 Planning, Development, and Responsibilities
- 1720.04 Permanent Facilities
- 1720.05 Portable Facilities
- 1720.06 Shoulder Sites
- 1720.07 Federal Participation
- 1720.08 Procedures
- 1720.09 Documentation

### 1720.01 General

Truck weighing facilities are needed to protect state highways from overweight vehicles, to provide for vehicle safety inspection, and to provide a source of data for planning and research. The development, construction, and maintenance of these facilities is a cooperative effort between the Washington State Department of Transportation (WSDOT) and the Washington State Patrol (WSP).

### 1720.02 Definitions

Note: For definitions of *roadway*, *traveled way*, *lane*, *median*, *outer separation*, *shoulder*, *decision sight distance*, *sight distance*, and *stopping sight distance*, see the [Glossary](#).

**Commercial Vehicle Information Systems and Networks (CVISN)** A network that links intelligent transportation systems (ITS) to share information on commercial vehicles. When in operation at a weigh site, it can enable commercial vehicles to clear the facility without stopping.

**frontage road** An auxiliary road that is a local road or street located beside a highway for service to abutting property and adjacent areas and for control of access.

**static scale** A scale that requires a vehicle to stop for weighing.

**usable shoulder** The width of the shoulder that can be used by a vehicle for stopping.

**weigh in motion (WIM)** A scale facility capable of weighing a vehicle without the vehicle stopping.

### 1720.03 Planning, Development, and Responsibilities

The WSP works with WSDOT Strategic Planning and Programming to develop a prioritized list of weigh facility needs for each biennium. The list includes:

- New permanent facilities.
- New portable facilities.
- New shoulder sites.
- WIM equipment.

- Vehicle inspection facilities.
- Scale approach slab reconstruction.

The WSP provides the Program Management Office of Strategic Planning and Programming a Project Definition, which includes:

- A statement of need, the purpose of the project, and the type of work.
- The general location of the project.

Program Management sends this information to the region for preparation of a Project Summary. The region works with the WSP to identify the specific location of the facility. The region then prepares a design decision estimate and submits it to Program Management.

The region negotiates and the Regional Administrator executes any formal agreements with the WSP required for the design, construction, or maintenance of vehicle weighing and inspection facilities.

The Memorandum of Understanding Related to Vehicle Weighing and Equipment: Inspection Facilities on State Highways, [Exhibit 1720-8](#), contains details about the various responsibilities of WSDOT and the WSP.

#### **1720.04 Permanent Facilities**

Permanent truck weighing facilities have permanent scales and may have buildings. When these facilities are in operation, trucks are required stop. However, when Weigh In Motion (WIM) and Commercial Vehicle Information Systems and Networks (CVISN) capabilities have been installed, the driver may be notified to continue without stopping. The notification to continue may be through the use of signs or transponders.

##### **(1) Site Locations**

The exact location of a truck weighing facility is generally controlled by topography, highway alignment, and geometrics. It is also desirable to select a site where adequate right of way is already available. Select the most economical site to minimize site preparation, expense, and impact on the environment. Water, electricity availability, and sewage treatment and disposal are other considerations for site selection. Additionally, use the following criteria:

- Locate the facility such that its operation will not hinder the operation of the highway or other related features such as intersections and interchanges.
- To the extent feasible, eliminate options for truck traffic to bypass the weigh site.
- Base the site selection on the type and volume of trucks using the route.

An [Access Revision Report](#) (ARR) is required for weigh sites on multilane divided highways with access control (see [Chapter 550](#)).

##### **(2) Design Features**

On multilane highways, provide off- and on-connections as shown in [Chapter 1360](#). [Exhibit 1720-1](#) is the minimal design of a weigh site on multilane highways.

Design weigh facilities on two-lane highways to best fit the existing conditions, with particular consideration given to the matter of access to and from the site. Off- and on-connections, as shown in [Chapter 1360](#), are preferred. However, with justification, on-connections may be designed as intersections (see [Chapter 1310](#)). [Exhibit 1720-2](#) is a guide for the design of weigh sites on two-lane highways.

The following special design features apply to weigh sites:

- Level cement concrete approach slabs are required at both ends of the scales.
- Hot mix asphalt (HMA) approach slabs will be allowed only when adequate soil conditions exist, projected truck volume is light, and benefit/cost analysis justifies the HMA based on the small percentage of time the scales will be in operation.
- The approach slabs must be level and in the same plane as the scale.
- Provide adequate parking and storage to ensure trucks do not impede the main line through traffic. The WSDOT Regional Administrator and the WSP agree on the area to be provided.
- On multilane divided highways, install illuminated electronically controlled “open” and “closed” message signs that can be operated from the scalehouse or the control cabinet. Provide permanent signing for the facility, as requested by the WSP.
- The need for a vehicle safety inspection facility at any site is identified by the WSP. [Exhibit 1720-3](#) is a guide for a site plan for a single-bay vehicle inspection facility. Additional bays and site adaptation will be on a site-by-site basis. The WSDOT Regional Administrator and the WSP agree on the area to be provided.
- The need for some form of approach protective treatment for the scale house or a protective fence between the scale and roadway is identified by the WSP and agreed upon by the WSDOT Regional Administrator and the WSP. The need for the device is to protect the scale house from errant vehicles. (See [Chapter 1600](#) for additional clear zone considerations.)
- The need for WIM or CVISN capabilities is identified by the WSP. Design the in-place facilities to provide the ability to notify drivers whether to continue on or to stop for further investigation before they reach the exit for the static scale. The design is agreed upon by the WSDOT Regional Administrator and the WSP.
- When WIM and CVISN are not included in the project, provide conduit for their future installation.
- With justification, at locations where space is limited, the depressed outer separation between the weigh facility and the through lanes may be replaced with concrete traffic barrier. (See the Collector-Distributor: Outer Separations exhibit in [Chapter 1360](#).)
- Provide a clear view of the entire weigh site for the facility’s operator and the driver of an approaching vehicle.
- Hot mix asphalt is acceptable for use on the ramp and storage areas. Design the depth in accordance with the surfacing report.
- To optimize scale efficiency, make the storage area flat; however, to facilitate drainage, the slope may be up to 2%.
- Provide illumination when requested by the WSP. Illumination is required if the facility is to be operated during the hours of darkness and may be desirable at other locations to deter unauthorized use of the facility. (See [Chapter 1040](#) for additional information on illumination.)

## 1720.05 Portable Facilities

Portable truck weighing facilities have no permanent scales or buildings. When these facilities are in operation, they operate in the same manner as permanent facilities.

### (1) Site Locations

Design portable truck weighing facilities located on two-lane and multilane roadways to best fit the existing conditions. Minor portable scale sites, as shown in [Exhibit 1720-4](#), are used with two-way traffic and on multilane highways with low traffic volumes. Major portable scale sites (see [Exhibit 1720-5](#)) are for use on expressways, freeways, and where traffic volumes are high.

Locate the weighing facility such that its operation will not hinder the operation of the highway or other related features such as intersections.

An [ARR](#) is required for weigh sites on multilane divided highways with access control (see [Chapter 550](#)).

### (2) Design Features

The following special design features apply to portable facilities:

- Off- and on-connections, as shown in Exhibits [1720-4](#) and [1720-5](#), are preferred; however, with justification on highways with no access control, on-connections may be designed as intersections (see [Chapter 1310](#)).
- With justification, at locations where space is limited, the depressed outer separation between the weigh facility and the through lanes may be replaced with concrete traffic barrier. (See the Collector-Distributor: Outer Separation exhibit in [Chapter 1360](#).)
- Provide adequate parking and storage to ensure trucks do not impede the main line through traffic. The WSDOT Regional Administrator and the WSP agree on the area to be provided.
- Hot mix asphalt is acceptable for use on the ramp and storage areas. Design the depth in accordance with the surfacing report.
- To optimize portable scale efficiency, make the storage area flat; however, to facilitate drainage, the slope may be up to 2%.
- Provide permanent signing for the facility, as requested by the WSP.
- Provide illumination when requested by the WSP. Illumination is required if the facility is to be operated during the hours of darkness and may be desirable at other locations to deter unauthorized use of the facility. (See [Chapter 1040](#) for additional information on illumination.)

## 1720.06 Shoulder Sites

Shoulder sites are used by the WSP to pull a truck over for inspection and weighing with portable scales.

### (1) Site Locations

Design shoulder sites to best fit the existing conditions. Small shoulder sites (see [Exhibit 1720-6](#)) are for use on lower-volume roadways (ADT 5000 or less) with two-way traffic. Large shoulder sites (see [Exhibit 1720-7](#)) are to be used with higher-volume two-way roadways and multilane highways.

**Acronyms**

**Glossary of Terms**

## Acronyms

AADT	Annual average daily traffic	HSS	Highways of Statewide Significance
ACT	Alternatives Comparison Table	ICD	Inscribed circle diameter
ADA	Americans with Disabilities Act of 1990	<u>ICE</u>	<u>Intersection Control Evaluation</u>
ADT	Annual daily traffic	ITS	Intelligent transportation systems
ALJ	Administrative law judge	L/A	Limited access
AOS	Apparent opening size	LOS	Level of service
APS	Accessible pedestrian signal	MEF	Maximum extent feasible
<u>ARR</u>	<u>Access Revision Report</u>	MOU	Memorandum of Understanding
AWDVTE	Average weekday vehicle trip ends	MPO	Metropolitan Planning Organization
B/C	Benefit / cost	NEPA	National Environmental Policy Act
BLM	Bureau of Land Management	NHS	National Highway System
BOD	Basis of Design	PAR	Pedestrian access route
BRT	Bus rapid transit	PCP	Pedestrian circulation path
BST	Bituminous surface treatment	PEL	Planning and Environmental Linkage
CAR	<u>Crash Analysis Report</u>	PF	Project File
CE	Categorical Exemption (SEPA)	PoDI	Project of Division Interest (FHWA)
CE	Categorical Exclusion (NEPA)	PS	Project Summary
CFA	Contributing Factors Analysis	PSF	Pounds per square foot
CFR	Code of Federal Regulations	PS&E	Plans, Specifications, and Estimates
CGT	Continuous Green "T" intersection	<u>QOL</u>	<u>Quality of Service</u>
CIPP	Capital Improvement and Preservation Program	R/W	Right of way
CPMS	Capital Program Management System	RCUT	Restricted Crossing U Turn
CRT	Controlled releasing terminal post	RCW	Revised Code of Washington
CSS	Context sensitive solutions	RFP	Request for Proposal
CTR	Commute Trip Reduction	ROD	Record of Decision
CVISN	Commercial Vehicle Inf. System and Networks	RTIP	Regional Transportation Improvement Program
DDHV	Directional design hour volume	RTPO	Regional Transportation Planning Organization
DDI	Diverging Diamond Interchange	SEPA	[Washington] State Environmental Policy Act
DDP	Design Documentation Package	SHS	Sustainable Highway Safety
DHV	Design hourly volume	SHSP	Strategic Highway Safety Plan
DLT	Displaced Left Turn	SIMMS	Signal Maintenance Management System
DNS	Determination of Nonsignificance (SEPA)	SOV	Single-occupant vehicle
DS	Determination of Significance (SEPA)	SRA	Safety rest area
E&EP	Environmental & Engineering Programs Division	SPUI	Single Point Urban Interchange
EA	Environmental Assessment (NEPA)	STIP	Statewide Transportation Improvement Program
EIS	Environmental Impact Statement	STP	Surface Transportation Program
ERS	Environmental Review Summary	TIA	Traffic Impact Analysis
FGTS	Freight and Goods Transportation System	TIP	Transportation Improvement Program
FHWA	Federal Highway Administration	TMA	Transportation Management Area
FONSI	Finding of No Significant Impact (NEPA)	TMP	Transportation management plan
FTA	Federal Transit Administration	TWLTL	Two-way left-turn lane
GIS	Geographic Information System	UPO	[Central Puget Sound] Urban Planning Office
GMA	Growth Management Act	USC	United States Code
HCM	Highway Capacity Manual	VE	Value engineering
HCP	Highway Construction Program	VECP	Value Engineering Change Proposal
HMA	Hot mix asphalt	VIC	Visitor Information Center
HOT	High-occupancy toll	VPH	Vehicles per hour
HOV	High-occupancy vehicle	WAC	Washington Administrative Code
HQ	WSDOT's Headquarters in Olympia	WIM	Weigh in motion
HSM	Highway Safety Manual	WSDOT	Washington State Department of Transportation
HSP	Highway System Plan	WSPMS	Washington State Pavement Management System
		WTP	Washington Transportation Plan



## Glossary of Terms

A B C D E F G H I J K L M N O P Q R S T U V W Y Z

### A

**access** A means of entering or leaving a public road, street, or highway with respect to abutting property or another public road, street, or highway.

**access break** Any point from inside or outside the state limited access right of way limited access hachures that crosses over, under, or physically through the plane of the limited access, is an access break or “break in access,” including, but not limited to, locked gates and temporary construction access breaks.

**access connection** An access point, other than a public road/street, that permits access to or from a managed access highway on the state highway system.

**access connection permit** A written authorization issued by the permitting authority for a specifically designed access connection to a managed access highway at a specific location; for a specific type and intensity of property use; and for a specific volume of traffic for the access connection based on the final stage of the development of the applicant’s property. The actual form used for this authorization is determined by the permitting authority.

**access control** The limiting and regulating of public and private access to Washington State’s highways, as required by state law. A *design control* (see [Chapter 1103](#)) – there are two categories of controlling access to state highways *limited access* and *managed access*.

**Access Control Tracking System Limited Access and Managed Access Master Plan** A database list, related to highway route numbers and mileposts, that identifies either the level of limited access or the class of managed access: [www.wsdot.wa.gov/design/accessandhearings](http://www.wsdot.wa.gov/design/accessandhearings)

**access density** The number of access points (driveways) per mile.

**access design analysis** A design analysis (see [Chapter 300](#)) that authorizes deferring or staging acquisition of limited access control, falling short of a 300-foot requirement, or allowing an existing access point to stay within 130 feet of an intersection on a limited access highway. Approval by the Director & State Design Engineer, Development Division, or designee, is required (see [Chapter 530](#)).

**access hearing plan** A limited access plan prepared for presentation at an access hearing.

**access management** The programmatic control of the location, spacing, design, and operation of driveways, median openings, interchanges, and street connections to a roadway.

**access point** Any point that allows private or public entrance to or exit from the traveled way of a state highway, including “locked gate” access and maintenance access points.

**access point revision** A new access point or a revision of an existing interchange/ intersection configuration. Locked gates and temporary construction breaks are also access point revisions.

**access point spacing** On a managed access highway, the distance between two adjacent access points on one side of the highway, measured along the edge of the traveled way from one access point to the next (see also [corner clearance](#)).

**access revision report (ARR)** A technical report which documents specific analyses in order to approve or reject a proposed revision to freeway access. See [Chapter 550](#).

**access report plan** A limited access plan prepared for presentation to local governmental officials at preliminary meetings before preparation of the access hearing plan.

**access rights** Property rights that allow an abutting property owner to enter and leave the public roadway system.

**accessible** Usable by persons with disabilities (ADA compliant). (ADA term)

**accessible pedestrian signal (APS)** A device that communicates information about the “WALK” phase in audible and vibrotactile (vibrating surface that communicates information through touch, located on the accessible pedestrian signal button) formats. (ADA term)

**accessible route** See [pedestrian access route](#). (ADA term)

**ADA** An abbreviation for the Americans with Disabilities Act of 1990. The ADA is a civil rights law that identifies and prohibits discrimination based on disability. Title II of the ADA requires public entities to design new pedestrian facilities or alter existing pedestrian facilities to be accessible to and usable by people with disabilities. (ADA term)

**adaptive lighting system** A lighting system with a control system connected, allowing for dimming, on/off operation by time of night, and independent scheduling of individual lights for select hours of operation during nighttime hours.

**affidavit of publication** A notarized written declaration stating that a notice of hearing (or notice of opportunity for a hearing) was published in the legally prescribed manner.

**affidavit of service by mailing** A notarized written declaration stating that the limited access hearing packet was mailed at least 15 days prior to the hearing and entered into the record at the hearing.

**alteration** A change to a facility in the public right of way that affects or could affect access, circulation, or use. Alterations include, but are not limited to: renovation; rehabilitation; reconstruction; historic restoration; resurfacing of circulation paths or vehicular ways; or changes or rearrangement of structural parts or elements of a facility. Alterations *do not* include: Spot pavement repair; liquid-asphalt sealing, chip seal (bituminous surface treatment), or crack sealing; or lane restriping that does not alter the usability of the shoulder. (ADA term)

**alternative(s)** Possible solutions to accomplish a defined purpose and need. These include local and state transportation system mode and design options, locations, and travel demand management and transportation system management-type improvements such as ramp metering, mass transit, and high-occupancy vehicle (HOV) facilities.

**Alternatives Comparison Table (ACT)** A table that documents and presents the tradeoffs among those performance metrics identified for each alternative under consideration on a project. The ACT is used to assist in analyzing the baseline and contextual performance tradeoffs and ultimately to select an alternative. It is a supplemental document to the “Alternatives Analysis” section of the *Basis of Design*.

**ancillary services** Those secondary services, also considered amenities, provided at safety rest areas that include, but are not limited to, vending machines, picnic areas, interpretive signing, telephones, recreational vehicle (RV) sanitary disposal facilities, trails, scenic viewpoints, commercial and public information displays, and visitor information centers.

**annual average daily traffic (AADT)** The total volume of traffic passing a point or segment of a highway facility in both directions for one year divided by the number of days in the year. Normally, periodic daily traffic volumes are adjusted for hours of the day counted, days of the week, and seasons of the year to arrive at average annual daily traffic.

**annual daily traffic (ADT)** The average 24 hour volume, being the total volume during a stated period divided by the number of days in that period. Normally, this would be periodic daily traffic volumes over several days, not adjusted for days of the week or seasons of the year.

**approach** An access point, other than a public road/street, that allows access to or from a limited access highway on the state highway system.

**approach and access connection** These terms are listed under the specific access section to which they apply. The first section below is for limited access highways and uses the term approach. The second section below is for managed access highways and uses the term access connection. Approaches and access connections include any ability to leave or enter a highway right of way other than at an intersection with another road or street.

(a) **limited access highways: approach** An access point, other than a public road/street, that allows access to or from a limited access highway on the state highway system. There are five types of approaches to limited access highways that are allowed:

- **Type A** An off and on approach in a legal manner, not to exceed 30 feet in width, for the sole purpose of serving a single-family residence. It may be reserved by the abutting owner for specified use at a point satisfactory to the state at or between designated highway stations. This approach type is allowed on partial and modified control limited access highways.
- **Type B** An off and on approach in a legal manner, not to exceed 50 feet in width, for use necessary to the normal operation of a farm, but not for retail marketing. It may be reserved by the abutting owner for specified use at a point satisfactory to the state at or between designated highway stations. This approach type is allowed on partial and modified control limited access highways. This approach type may be used for wind farms when use of the

approach is limited to those vehicles necessary to construct and maintain the farm for use in harvesting wind energy.

- **Type C** An off and on approach in a legal manner, for a special purpose and width to be agreed upon. It may be specified at a point satisfactory to the state at or between designated highway stations. This approach type is allowed on partial and modified control limited access highways and on full control limited access highways where no other reasonable means of access exists, as solely determined by the department.
- **Type D** An off and on approach in a legal manner, not to exceed 50 feet in width, for use necessary to the normal operation of a commercial establishment. It may be specified at a point satisfactory to the state at or between designated highway stations. This approach type is allowed only on modified control limited access highways.
- **Type E** This type is no longer allowed to be constructed because of the requirements that there be only one access point per parcel on a limited access state highway.
- **Type F** An off and on approach in a legal manner, not to exceed 30 feet in width, for the sole purpose of serving a wireless communication site. It may be specified at a point satisfactory to the state at or between designated highway stations. This approach type is allowed only on partial control limited access highways. (See WAC [468 58 080\(vi\)](#) for further restrictions.)

(b) **managed access highways: access connection** An access point, other than a public road/street, that permits access to or from a managed access highway on the state highway system. There are five types of access connection permits:

- **conforming access connection** A connection to a managed access highway that meets current WAC and WSDOT location, spacing, and design criteria.
- **grandfathered access connection** Any connection to the state highway system that was in existence and in active use on July 1, 1990, and has not had a significant change in use.
- **joint-use access connection** A single connection to a managed access highway that serves two or more properties.
- **nonconforming access connection** A connection to a managed access highway that does not meet current WSDOT location, spacing, or design criteria, pending availability of a future conforming access connection.
- **variance access connection** A connection to a managed access highway at a location not normally allowed by current WSDOT criteria.

(c) **managed access connection category** There are four access connection permit categories for managed access connections to state highways: Category I, Category II, Category III, and Category IV (see [Chapter 540](#)).

**area of influence** The area that will be directly impacted by the proposed action: freeway main line, ramps, crossroads, immediate off-system intersections, and state and local roadway systems.

**articulated bus** A two-section bus that is permanently connected at a joint.

**auxiliary aids and services** (1) Qualified interpreters, notetakers, transcription services, written materials, telephone handset amplifiers, assistive listening devices, assistive listening systems, telephones compatible with hearing aids, open and closed captioning, telecommunications devices for persons with hearing or speech difficulties (TDDs), videotext displays, or other effective methods for making aurally delivered materials available to individuals with hearing limitations; (2) Qualified readers, taped texts, audio recordings, Brailled materials, large print materials, or other effective methods for making visually delivered materials available to individuals with visual impairments; (3) Acquisition or modification of equipment or devices; (4) Other similar services and actions; and (5) Providing and disseminating information, written materials, and notices in languages other than English, where appropriate.

**auxiliary lane** The portion of the roadway adjoining the through lanes for parking, speed change, turning, storage for turning, weaving, truck climbing, and other purposes supplementary to through-traffic movement.

**average light level** The average of all light intensities within the design area.

**average weekday vehicle trip ends (AWDVTE)** The estimated total of all trips entering plus all trips leaving a road approach on a weekday for the final stage of development of the property served by the road approach.

## **B**

**backslope** A sideslope that goes up as the distance increases from the roadway (cut slopes).

**barrier terminal** A crash-tested end treatment for longitudinal barriers that is designed to reduce the potential for spearing, vaulting, rolling, or excessive deceleration of impacting vehicles from either direction of travel. Barrier terminals include applicable anchorage.

**baseline** The approved time phased plan (for a project, a work breakdown structure component, a work package, or a schedule activity), plus or minus approved project scope, cost, schedule, and technical changes. Generally refers to the current baseline, but may refer to the original or some other baseline. Usually used with a modifier (e.g., cost baseline, schedule baseline, performance measurement baseline, technical baseline).

**baseline performance metric** A description of need in terms that can be measured or assessed in both the existing and proposed (future) state.

**baseline performance need** The primary reason a project has been proposed. It refers to the threshold determination at the project location resulting from a statewide biennial prioritization and funding process. It may also be the specific issue to be addressed by the project described by a partnering agency that is providing the funding.

**basic number of lanes** The minimum number of general purpose lanes designated and maintained over a significant length of highway.

**Basis of Design (BOD)** A document and template used to record information, decisions, and analysis needed in the development of a project design, including all factors leading to the development and selection of a project alternative, and the selection of design elements associated with that alternative.

**benefit/cost analysis** A method of valuing a proposition by first monetizing all current expenditures to execute—cost—as well as the expected yields into the future—benefit, then dividing the total benefit by the total cost, thus providing a ratio. Alternatives may be rendered and compared in this fashion where, typically, a higher ratio is preferable, indicating a better return on investment.

**bicycle** Any device propelled solely by human power upon which a person or persons may ride, having two tandem wheels, either of which is 16 inches or more in diameter, or three wheels, any one of which is more than 20 inches in diameter.

**bicycle route** A system of facilities that is used or has a high potential for use by bicyclists or that is designated as such by the jurisdiction having the authority. A series of bicycle facilities may be combined to establish a continuous route and may consist of any or all types of bicycle facilities.

**bike lane** A portion of a highway or street identified by signs and pavement markings as reserved for bicycle use.

**buffer** A space measured from the back of the curb to the edge of the sidewalk that could be treated with plantings or alternate pavement, or be used for needs such as drainage treatment or utility placement. (ADA term)

**buffer-separated HOV lane** An HOV lane that is separated from the adjacent same direction general-purpose freeway lanes by a designated buffer.

**bus** A rubber-tired motor vehicle used for transportation, designed to carry more than ten passengers.

**business access transit (BAT) lanes** A transit lane that allows use by other vehicles to access abutting businesses.

**bus pullout** A bus stop with parking area designed to allow transit vehicles to stop wholly off the roadway.

**bus rapid transit (BRT)** An express rubber tired transit system operating predominantly in roadway managed lanes. It is generally characterized by separate roadway or buffer-separated HOV lanes, HOV direct access ramps, and a high-occupancy designation (3+ or higher).

**bus shelter** A facility that provides seating and protection from the weather for passengers waiting for a bus.

**bus stop** A place designated for transit vehicles to stop and load or unload passengers.

## C

**capacity** The maximum sustainable flow rate at which vehicles or persons can reasonably be expected to traverse a point or uniform segment of a lane or roadway during a specified time period under given roadway, geometric, traffic, environmental, and control conditions. Capacity is usually expressed as vehicles per hour (vph), passenger cars per hour (pcph), or persons per hour (pph).

**Capital Improvement and Preservation Program (CIPP)** WSDOT's program of projects developed each biennium that delivers capital investments in highway, marine, and rail facilities that have been funded in part or in whole by the state Legislature. The CIPP is submitted to the Governor and, ultimately, by the Governor to the Legislature.

**Categorical Exclusion (CE) (NEPA) or Categorical Exemption (CE) (SEPA)** Actions that do not individually or cumulatively have a significant effect on the environment.

**central island** The area of the roundabout, including the truck apron, surrounded by the circulating roadway.

**central island diameter** The diameter of the central island, including the truck apron (see [Chapter 1320](#)).

**circulating lane** A lane used by vehicles circulating in the roundabout.

**circulating roadway** The traveled lane(s) adjacent to the central island and outside the truck apron, including the entire 360° circumference of the circle.

**circulating roadway width** The total width of the circulating lane(s) measured from inscribed circle to the central island (see [Chapter 1320](#)).

**clear run-out area** The area beyond the toe of a nonrecoverable slope available for use by an errant vehicle.

**clear width** The unobstructed width within a pedestrian circulation path. The clear width within a pedestrian circulation path must meet the accessibility criteria for a pedestrian access route. (ADA term)

**clear zone** The total roadside border area, available for use by errant vehicles, starting at the edge of the traveled way and oriented from the outside or inside shoulder (in median applications) as applicable. This area may consist of a shoulder, a recoverable slope, a nonrecoverable slope, and/or a clear run-out area. The clear zone cannot contain a critical fill slope, fixed objects, or water deeper than 2 feet.

**climate change vulnerability** The risk a transportation facility will be impacted by the effects of climate change.

**climbing lane** An auxiliary lane used for the diversion of slow traffic from the through lane.

**collector** A context description of a roadway intended to provide a mix of access and mobility performance. Typically low speed, collecting traffic from local roads and connecting them with destination points or arterials. This term is used in multiple classification systems, but is most commonly associated with the *Functional Classification System*.

**collector-distributor road (C-D road)** A parallel roadway designed to remove weaving from the main line and reduce the number of main line entrances and exits.

**collector system** Routes that primarily serve the more important intercounty, intracounty, and intraurban travel corridors; collect traffic from the system of local access roads and convey it to the arterial system; and on which, regardless of traffic volume, the predominant travel distances are shorter than on arterial routes ([RCW 47.05.021](#)).

**Commercial Vehicle Information Systems and Networks (CVISN)** A network that links intelligent transportation systems (ITS) to share information on commercial vehicles. When in operation at a weigh site, it can enable commercial vehicles to clear the facility without stopping.

**complex ramp alignment and grade** As related to [Chapter 1040 Illumination](#). The exit advisory speed is 35 mph or lower than the posted main line speed, or there is a 6% or greater change in grade from existing main line grade to the ramp grade.

**conflict point** A point where road user paths cross, merge, or diverge.

**consider** To think carefully about, especially in order to make a decision. The decision to document a consideration is left to the discretion of the engineer.

**construction impact zone** The area in which an alteration to an existing facility takes place (also known as the project footprint). If a crosswalk (marked or unmarked) will be reconstructed, paved (overlay or inlay), or otherwise altered as part of a project, then the curb ramps that serve that crosswalk are within the construction impact zone. (ADA term)

**context** Refers to the environmental, economic, and social features that influence livability and travel characteristics. Context characteristics provide insight into the activities, functions, and performance that can be influenced by the roadway design. Context also informs roadway design, including the selection of design controls, such as target speed and modal priority, and other design decisions. See [Chapter 1102](#).

**context categories** The naming convention used to describe either a land use or transportation context (see [Chapter 1102](#)).

**context characteristic** A distinguishing trait within a context, either land use or transportation. [Chapter 1102](#) lists several common characteristics that help distinguish between one type of context versus another. There may be additional traits not covered in the chapter.

**contextual performance metric** A restatement of a contextual performance need in terms that can be measured or assessed in both the existing and proposed (future) state.

**contextual performance need** A statement of need that applies to a project location which has not been identified as a baseline need.



**contiguous parcels** Two or more pieces of real property, under the same ownership, with one or more boundaries that touch and have similarity of use.

**continuous load** The electrical load on a circuit that lasts for a duration of three or more hours on any day.

**contributing factors** Those operational conditions, human factors, context conditions, design elements, design controls, or actions identified by data, engineering judgment, or the community that contribute to a performance need under evaluation.

**controlled releasing terminal (CRT) post** A standard-length guardrail post that has two holes drilled through it so it might break away when struck.

**conventional traffic signal** A permanent or temporary installation providing alternating right of way assignments for conflicting traffic movements. At least two identical displays are required for the predominant movement on each approach.

**corner clearance** On a managed access highway, the distance from an intersection of a public road or street to the nearest access connection along the same side of the highway. The minimum corner clearance distance (see [Chapter 540](#)) is measured from the closest edge of the intersecting road or street to the closest edge of the traveled way of the access connection, measured along one side of the traveled way (through lanes) (see also [access point spacing](#)).

**corridor sketch** An information source that describes the attributes of a state highway corridor, its current and future function, as well as its performance expectations. It will ultimately identify cost-effective strategies for future consideration. A completed corridor sketch may have information that is valuable at the project level in determining contextual performance needs, and project alternatives. A corridor sketch is not a substitute for detailed planning and analysis, nor is it a list of investments or projects.

**corridor vision** The future transportation context from a regional perspective. Practical Design considers and accounts for the contextual needs of the longer section of highway in the development and evaluation of alternatives to ensure a favorable outcome for the greater system.

**counter slope** The slope of the gutter or roadway at the foot of a curb ramp or landing where it connects to the roadway, measured along the axis of the running slope extended. (ADA term)

**countermeasure** An action taken to counteract an existing or anticipated condition.

**court reporter** A person with a license to write and issue official accounts of judicial or legislative proceedings.

**Crash Analysis Report (CAR)** A template that is used for [documenting required analysis for I-2 CAL/CAC/IAL projects](#), as described in [Chapter 321](#).

**critical fill slope** A slope on which a vehicle is likely to overturn. Slopes steeper than 3H:1V are considered critical fill slopes.

**cross slope** The slope measured perpendicular to the direction of travel. (ADA term)

**crossroad** The minor roadway at an intersection. At a stop-controlled intersection, the crossroad has the stop.

**crosswalk** A marked or unmarked pedestrian crossing, typically at an intersection, that connects the pedestrian access routes on opposite sides of a roadway. A crosswalk must meet accessibility criteria. A crosswalk is also defined as:

- "...the portion of the roadway between the intersection area and a prolongation or connection of the farthest sidewalk line or in the event there are no sidewalks then between the intersection area and a line ten feet therefrom, except as modified by a marked crosswalk" (RCW 46.04.160).
- "(a) That part of a roadway at an intersection included within the connections of the lateral lines of the sidewalks on opposite sides of the highway measured from the curbs or in the absence of curbs, from the edges of the traversable roadway, and in the absence of a sidewalk on one side of the roadway, the part of the roadway included within the extension of the lateral lines of the sidewalk at right angles to the center line; (b) any portion of a roadway at an intersection or elsewhere distinctly indicated as a pedestrian crossing by lines on the surface, which might be supplemented by contrasting pavement texture, style, or color" (MUTCD, 2003; *Guide for the Planning, Design, and Operation of Pedestrian Facilities*, AASHTO, 2004). (ADA term)

**curb extension** A curb and sidewalk bulge or extension out into the parking lane used to decrease the length of a pedestrian crossing and increase visibility for the pedestrian and driver. (ADA term)

**curb ramp** A combined ramp and landing to accomplish a change in level at a curb. This element provides street and sidewalk access to pedestrians with mobility impairments. (ADA term)

- **parallel curb ramp** A curb ramp design where the sidewalk slopes down to a landing at road level with the running slope of the ramp in line with the direction of sidewalk travel
- **perpendicular curb ramp** A curb ramp design where the ramp path is perpendicular to the curb and meets the gutter grade break at a right angle.

**curb section** A roadway cross section with curb and sidewalk.

---

**D**

**decision sight distance** The distance needed for a driver to detect an unexpected or difficult-to-perceive condition, recognize the condition, select an appropriate maneuver, and complete the maneuver based on design conditions and design speed.

**deflection** (in respect to roundabouts) The change in the path of a vehicle imposed by the geometric features of a roundabout resulting in a slowing of vehicles.

**delineation** Any method of defining the roadway operating area for the driver.

**deliverable** Any unique and verifiable product, result or capability to perform a service that must be produced to complete a process, phase, or project.

**Design Analysis** A process and tool to record design element changes where the dimensions chosen do not meet the value, or lie within the range of values, provided for that element in the *Design Manual*. (see Chapters [300](#) and [1106](#)).

**Design Approval** Documented approval of the design at this early milestone locks in design policy for three years. Design approval becomes part of the Design Documentation Package (see [Chapter 300](#).)

**design-bid-build** The project delivery method where design and construction are sequential steps in the project development process ([23 CFR 636.103](#)).

**design-build contract** An agreement that provides for design and construction of improvements by a consultant/contractor team. The term encompasses design-build-maintain, design-build-operate, design-build-finance, and other contracts that include services in addition to design and construction. Franchise and concession agreements are included in the term if they provide for the franchisee or concessionaire to develop the project that is the subject of the agreement ([23 CFR 636.103](#)).

**design-builder** The firm, partnership, joint venture, or organization that contracts with WSDOT to perform the work.

**design controls** Key parameters that critically shape design decisions and effect calculated dimensions for some design elements. Design controls are conscientiously selected and work together with the context characteristics to achieve a particular outcome (see [Chapter 1103](#))

**Design Clear Zone** The minimum clear zone target value used in highway design.

**Design Documentation Package (DDP)** See [Project File](#).

**design element** Any component or feature associated with roadway design that becomes part of the final product. Examples include lane width, shoulder width, alignment, and clear zone (see [Chapter 1105](#).)

**designer** This term applies to WSDOT design personnel. Wherever “designer” appears in this manual, design-build personnel shall deem it to mean: Engineer of Record, Design Quality Assurance Manager, design-builder, or any other term used in the design-build contract to indicate design-build personnel responsible for the design elements of a design-build project, depending on the context of information being conveyed.

**design hourly volume (DHV)** Computed by taking the annual average daily traffic times the K-factor. It can only be accurately determined in locations where there is a permanent traffic recording device active 365 days of the year. It correlates to the peak hour (see [peak hour](#)), but it is not equivalent. In some circumstances, it is necessary to use the peak hour data instead of DHV because peak hour can be collected using portable traffic recorders.

**design speed** A design control; the speed used to determine the various geometric design features of the roadway.

**design up** An approach to developing project alternatives utilizing the smallest dimensions that meet the need by providing the desired performance.

**design users** A broad term intended to capture all modal users that currently utilize or are legally permitted on a roadway segment or node.

**design variance** Same as Design Analysis.

**design vehicle** See [intersection design vehicle](#).

**design year** The forecast year used for design as described in [Chapter 1103](#). See also [horizon year](#).

**desirable** Design criteria that are recommended for inclusion in the design.

**detectable warning surface** A tactile surface feature of truncated dome material built into or applied to the walking surface to alert persons with visual impairments of vehicular ways. Federal yellow is the color used on WSDOT projects to achieve visual contrast. Colors other than federal yellow that meet the light-on-dark/dark-on-light requirement may be used on projects where cities have jurisdiction. (Detectable warning surfaces are detailed in the [Standard Plans](#).) (ADA term)

**Determination of Nonsignificance (DNS) (SEPA)** The written decision by the Regional Administrator that a proposal will not have a significant impact and no EIS is required.

**Determination of Significance (DS) (SEPA)** A written decision by the Regional Administrator that a proposal could have a significant adverse impact and an EIS is required.

**directional design hour volume (DDHV)** The traffic volume for the design hour in the peak direction of flow, in vehicles per hour. For example, if during the design hour, 60% of the vehicles traveled eastbound and 40% traveled westbound, then the DDHV for the eastbound direction would be the DHV x 0.60.

**divided multilane** A roadway with two or more through lanes in each direction and a median that physically or legally prohibits left turns, except at designated locations.

**document** (verb) The act of including a short note to the Design Documentation Package that explains a design decision.

**dooring** Describes a conflict with a parked vehicle door opening into a roadway bike facility.

**driveway** A vehicular access point that provides access to or from a public roadway.

## E

**easement** A documented right, as a right of way, to use the property of another for designated purposes.

**element** An architectural or mechanical component or design feature of a space, site, or public right of way.

**emergency escape ramp** A roadway leaving the main roadway designed for the purpose of slowing and stopping out-of-control vehicles away from the main traffic stream.

**emergency vehicle signal** A special adaptation of a conventional traffic signal installed to allow for the safe movement of authorized emergency vehicles. Usually, this type of signal is installed on the highway at the entrance into a fire station or other emergency facility. The signal ensures protected entrance onto the highway for the emergency vehicle. When not providing for this movement, the signal either operates continuously (consistent with the requirements for a conventional traffic signal) or displays continuous green, which is allowed at non-intersection locations only. At least two identical displays are required per approach.

**enforcement observation point** A place where a law enforcement officer may park and observe traffic.

**entry angle** The angle between the entry roadway and the circulating roadway measured at the yield point (see [Chapter 1320](#)).

**entry curve** The curve of the left edge of the roadway that leads into the circulating roadway (see [Chapter 1320](#)).

**entry width** The width of an entrance leg at the inscribed circle measured perpendicular to travel (see [Chapter 1320](#)).

**Environmental Assessment (EA)** (NEPA) A document prepared for federally funded, permitted, or licensed projects that are not categorical exclusions (CE), but do not appear to be of sufficient magnitude to require an EIS. The EA provides enough analysis to determine whether an EIS or a FONSI should be prepared.

**Environmental Impact Statement (EIS)** A detailed written statement of a proposed course of action, project alternatives, and possible impacts of the proposal.

**Environmental Review Summary (ERS)** (see [Project Summary](#)) Part of the Project Summary document, the ERS identifies environmental permits and approvals. It is prepared in the region and is required for Design Approval.

**expressway** A divided highway that has a minimum of two lanes in each direction for the exclusive use of traffic and that may or may not have grade separations at intersections. A transportation context characteristic that is designated for a divided highway with limited access that provides regional mobility.

**extrude** A procedure for applying marking material to a surface by forcing the material through a die to give it a certain shape.

## F

**facility** All or any portion of buildings, structures, improvements, elements, and pedestrian or vehicular routes located in a public right of way.

**feature** A component of a pedestrian access route, such as a curb ramp, driveway, crosswalk, or sidewalk.

**Federal Highway Administration (FHWA)** The division of the U.S. Department of Transportation with jurisdiction over the use of federal transportation funds for state highway and local road and street improvements.

**Federal Transit Administration (FTA)** The division of the U.S. Department of Transportation with jurisdiction over the use of federal funds for financial assistance to develop new transit systems and improve, maintain, and operate existing systems.

**final design** Any design activities following preliminary design; expressly includes the preparation of final construction plans and detailed specifications for the performance of construction work ([23 CFR 636.103](#)). Final design is also defined by the fact that it occurs after NEPA/SEPA approval has been obtained.

**Finding of No Significant Impact (FONSI) (NEPA)** A federal document indicating that a proposal will not significantly affect the environment and an EIS is not required.

**findings and order** A document containing the findings and conclusions of a limited access hearing approved by the Assistant Secretary, Engineering & Regional Operations (see [Chapter 210](#)).

**findings and order plan** A limited access plan, prepared after a limited access hearing, which is based on the hearing record.

**fixed feature (object to be mitigated)** A fixed object, a side slope, or water that, when struck, can result in impact forces on a vehicle's occupants that may result in injury or place the occupants in a situation that has a high likelihood of injury. A fixed feature can be either constructed or natural.

**flangeway gap** The gap for the train wheel at a railroad crossing. The space between the inner edge of a rail and the pedestrian crossing surface. (ADA term)

**flare** The widening of the approach to the roundabout to increase capacity and facilitate natural vehicle paths.

**flyer stop** A transit stop inside the limited access boundaries.

**footcandle (fc)** The illumination of a surface one square foot in area on which a flux of one lumen is uniformly distributed. One footcandle equals one lumen per square foot.

**foreslope** A sideslope that goes down as the distance increases from the roadway (fill slopes and ditch inslopes).

**freeway** A divided highway that has a minimum of two lanes in each direction for the exclusive use of traffic and with full control of access.

**frontage road** An auxiliary road that is a local road or street located beside a highway for service to abutting property and adjacent areas and for control of access.

**functional classification** The grouping of streets and highways according to the character of the service they are intended to provide.

## G

**geocomposites** Prefabricated edge drains, wall drains, and sheet drains that typically consist of a cusped or dimpled polyethylene drainage core wrapped in a geotextile. The geotextile wrap keeps the core clean so that water can freely flow through the drainage core, which acts as a conduit. Prefabricated edge drains are used in place of shallow geotextile-wrapped trench drains at the edges of the roadway to provide subgrade and base drainage. Wall drains and sheet drains are typically placed between the back of the wall and the soil to drain the soil retained by the wall.

**Geographic Information System (GIS)** A computerized geographic information system used to store, analyze, and map data. Data may be used with GIS if the data includes the Accumulated Route Mile (ARM) or State Route Milepost (SRMP) programs. Global Positioning System (GPS) technology provides a means of collecting data and is an alternative to ARM and SRMP. WSDOT's primary desktop tool to view and analyze GIS data is ArcGIS software. GIS is used to gather and analyze data to support the purpose and need as described in the Project Summary (<http://wwwi.wsdot.wa.gov/gis/supportteam/default.asp>).

**geogrids** A polymer grid mat constructed either of coated yarns or a punched and stretched polymer sheet. Geogrids usually have high strength and stiffness and are used primarily for soil reinforcement.

**geomembranes** Impervious polymer sheets that are typically used to line ponds or landfills. In some cases, geomembranes are placed over moisture-sensitive swelling clays to control moisture.

**geonets** Similar to geogrids, but typically lighter weight and weaker, with smaller mesh openings. Geonets are used in light reinforcement applications or are combined with drainage geotextiles to form a drainage structure.

**geosynthetic erosion control** The minimizing of surficial soil particle movement due to the flow of water over the surface of bare soil or due to the disturbance of soil caused by construction activities under or near bodies of water. This is the primary function of geotextiles used as silt fences or placed beneath riprap or other stones on soil slopes. Silt fences keep eroded soil particles on the construction site, whereas geotextiles placed beneath riprap or other stones on soil slopes prevent erosion from taking place at all. In general, the permanent erosion control methods described in [Chapter 630](#) are only used where more natural means (like the use of biodegradable vegetation mats to establish vegetation to prevent erosion) are not feasible. These functions control some of the geosynthetic properties, such as apparent opening size (AOS) and permittivity, and in some cases load-strain characteristics. The application will also affect the geosynthetic installation conditions. These installation conditions influence the remaining geosynthetic properties needed, based on the survivability level required.

**geosynthetic filtration** The passage of water through the geosynthetic relatively unimpeded (permeability or permittivity) without allowing passage of soil through the geosynthetic (retention). This is the primary function of geotextiles in underground drainage applications.

**geosynthetic survivability** The ability of the geosynthetic to resist installation conditions without significant damage, such that the geosynthetic can function as intended. Survivability affects the strength properties of the geosynthetic required.

**geotextiles (nonwoven)** A sheet of continuous or staple fibers entangled randomly into a felt for needle-punched nonwovens and pressed and melted together at the fiber contact points for heat-bonded nonwovens. Nonwoven geotextiles tend to have low-to-medium strength and stiffness with high elongation at failure and relatively good drainage characteristics. The high elongation characteristic gives them superior ability to deform around stones and sticks.

**geotextiles (woven)** Slit polymer tapes, monofilament fibers, fibrillated yarns, or multifilament yarns simply woven into a mat. Woven geotextiles generally have relatively high strength and stiffness and, except for the monofilament wovens, relatively poor drainage characteristics.

**gore** The area downstream from the intersection of the shoulders of the main line and exit ramp. Although generally referring to the area between a main line and an exit ramp, the term may also be used to refer to the area between a main line and an entrance ramp.

**gore nose** At an exit ramp, the point at the end of the gore area where the paved shoulders of the main line and the ramp separate (see [Chapter 1360](#)) or the beginning of traffic barrier, not including any impact attenuator. Also, the similar point at an entrance ramp.

**grade break** The intersection of two adjacent surface planes of different grade. (ADA term)



---

**H**

**hearing** An assembly to which the public is invited and at which participation is encouraged. Types of hearings include:

- **administrative appeal hearing** A formal process whereby a property owner may appeal WSDOT's implementation of access management legislation. The appeal is heard by an administrative law judge (ALJ), who renders a decision. (See [Chapter 540](#) for administrative appeal hearing procedures.)
- **combined hearing** A hearing held when there are public benefits to be gained by combining environmental, corridor, design, and/or limited access subjects.
- **corridor hearing** A formal or informal hearing that presents the corridor alternatives to the public for review and comment before a commitment is made to any one route or location. This type of hearing is beneficial for existing corridors with multiple Improvement projects programmed over a long duration.
- **design hearing** A formal or informal hearing that presents the design alternatives to the public for review and comment before the selection of a preferred alternative.
- **environmental hearing** A formal or informal hearing documenting that social, economic, and environmental impacts have been considered and that public opinion has been solicited.
- **formal hearing format** A hearing conducted by a moderator using a formal agenda, overseen by a hearing examiner, and recorded by a court reporter, as required by law. Limited access hearings require the use of the formal hearing format (see [Chapter 210](#)).
- **informal hearing format** A hearing where oral comments are recorded by a court reporter, as required by law. An informal hearing often uses the "open house" format (see [Chapter 210](#)). A formal agenda and participation by a hearing examiner are optional.
- **limited access hearing** A formal hearing that gives local public officials, owners of abutting properties, and other interested persons an opportunity to be heard about the limitation of access to the highway system.

**hearing agenda** An outline of the actual public hearing elements, used with formal hearings. (See [Chapter 210](#) for contents.)

**Hearing Coordinator** The HQ Access and Hearings Section Manager: (360) 705-7266.

**hearing examiner** An administrative law judge from the Office of Administrative Hearings, or a WSDOT designee, appointed to moderate a hearing.

**hearing script** A written document of text to be presented orally by department representatives at a hearing.

**hearing summary** Documentation prepared by the region and approved by Headquarters that summarizes environmental, corridor, and design hearings. (See [Chapter 210](#) for content requirements.)

**hearing transcript** A document prepared by the court reporter that transcribes verbatim all oral statements made during the hearing, including public comments. This document becomes part of the official hearing record.

**high-occupancy toll (HOT) lane** A managed lane that combines a high-occupancy vehicle lane and a toll lane.

**high-occupancy vehicle (HOV)** A vehicle that meets the occupancy requirements of the facility as authorized by [WAC 468-510-010](#).

**high pavement type** Portland cement concrete pavement or hot mix asphalt (HMA) pavement on a treated base.

**highway** A general term denoting a street, road, or public way for the purpose of vehicular travel, including the entire area within the right of way.

**Highway Construction Program (HCP)** A comprehensive multiyear program of highway Improvement and Preservation projects selected by the Legislature.

**Highway System Plan (HSP)** A WSDOT planning document that addresses the state highway system element of the Washington Transportation Plan (WTP). The HSP defines the service objectives, action strategies, and costs to maintain, operate, preserve, and improve the state highway system for 20 years. The HSP is the starting point for the state highway element of the CIPP and the state Highway Construction Program. It is periodically updated to reflect completed work and changing transportation needs, policies, and revenues. It compares highway needs to revenues, describes the “constrained” costs of the highway programs, and provides details of conceptual solutions and performance in the improvement program.

**Highways of Statewide Significance (HSS)** Include interstate highways and other principal arterials that are needed to connect major communities in the state. The designation helps assist with the allocation and direction of funding. (<http://www.wsdot.wa.gov/planning/HSS>)

**Horizon year** Typically considered to be 20 years from the year construction is scheduled to begin, as described in [Chapter 1103](#). See also design year.

**HOV direct access ramp** An on- or off-ramp exclusively for the use of HOVs that provides access between a freeway HOV lane and a street, transit support facility, or another freeway HOV lane without weaving across general-purpose lanes.

**HOV facility** A priority treatment for HOVs.

## I

**impact attenuator system** A device that acts primarily to bring an errant vehicle to a stop at a deceleration rate tolerable to the vehicle’s occupants or to redirect the vehicle away from a fixed feature.

**incorporated city or town** A city or town operating under [RCW 35](#) or [35A](#).

**inscribed circle** The outer edge of the circulating roadway.

**inscribed circle diameter (ICD)** The diameter of the inscribed circle (see [Chapter 1320](#)).

***inner corridor access*** a means of entering or leaving a roadside area inside of the state limited access right of way without crossing over, under, or physically through the plane of limited access.

***intelligent transportation systems (ITS)*** An integrated system of advanced sensor, computer, electronics, and communication technologies and management strategies, used to increase the safety and efficiency of the surface transportation system.

***interchange*** A system of interconnecting roadways, in conjunction with one or more grade separations, providing for the exchange of traffic between two or more intersecting highways or roadways.

***intermediate pavement type*** Hot mix asphalt pavement on an untreated base.

***intersection*** An at-grade access point connecting a state highway with a road or street duly established as a public road or public street by the local governmental entity.

***intersection angle*** The angle between any two intersecting legs at the point the centerlines intersect.

***intersection area*** The area of the intersecting roadways bounded by the edge of traveled ways and the area of the adjacent roadways to the farthest point: (a) the end of the corner radii, (b) through any marked crosswalks adjacent to the intersection, (c) to the stop bar, or (d) 10 feet from the edge of shoulder of the intersecting roadway (see [Chapter 1310](#)).

***Intersection, at grade*** The general area where a roadway or ramp terminal is met or crossed at a common grade or elevation by another roadway.

- ***four-leg intersection*** An intersection formed by two crossing roadways.
- ***split tee*** A four-leg intersection with the crossroad intersecting the through roadway at two tee intersections offset by at least the width of the roadway.
- ***tee (T) intersection*** An intersection formed by two roadways where one roadway terminates at the point it meets a through roadway.
- ***wye (Y) intersection*** An intersection formed by three legs in the general form of a “Y” where the angle between two legs is less than 60°.

***intersection control beacon (also flashing beacon)*** A secondary control device, generally suspended over the center of an intersection, that supplements intersection warning signs and stop signs. One display per approach may be used; however, two displays per approach are desirable. Intersection control beacons are installed only at intersections that control two or more directions of travel.

***intersection leg*** Any one of the roadways radiating from and forming part of an intersection.

- ***entrance leg*** The lanes of an intersection leg for traffic entering the intersection.
- ***exit leg*** The lanes of an intersection leg for traffic leaving the intersection.

**Note:** Whether an intersection leg is an entrance leg or an exit leg depends on which movement is being analyzed. For two-way roadways, each leg is an entrance leg for some movements and an exit leg for other movements.

**intersection density** The ratio of intersections per mile.

**intersection design vehicle** A specific selection of the vehicle to be used to dimension intersection design elements at an individual intersection.

**intersection sight distance** The length of roadway visible to the driver of a vehicle entering an intersection.

**Interstate System** A network of routes designated by the state and the Federal Highway Administration (FHWA) under terms of the federal-aid acts as being the most important to the development of a national system. The Interstate System is part of the principal arterial system.

**island** A defined area within an intersection, between traffic lanes, for the separation of vehicle movements or for pedestrian refuge.

## J

**justify** Preparing a memo to the DDP identifying the reasons for the decision: a comparison of advantages and disadvantages of all options considered. A more rigorous effort than document.

## K

**K-factor** The proportion of AADT occurring in the analysis hour is referred to as the K-factor, expressed as a decimal fraction (commonly called “K,” “K30,” or “K100”). The K30 is the thirtieth (K100 is the one-hundredth) highest peak hour divided by the annual average daily traffic. Normally, the K30 or K100 will be in the range of 0.09 to 0.10 for urban and rural areas. Average design hour factors are available on the web in the [Transportation Data, GIS & Modeling Office’s Annual Peak Hour Report](#).

## L

**lamp lumens** The total light output from a lamp, measured in lumens.

**lane** A strip of roadway used for a single line of vehicles.

**lane control signal** (reversible lanes) A special overhead signal that permits, prohibits, or warns of impending prohibition of lane use.

**lane width** The lateral design width for a single lane, striped as shown in the [Standard Plans](#) and the [Standard Specifications](#). The width of an existing lane is measured from the edge of traveled way to the center of the lane line or between the centers of adjacent lane lines.

**landing** A level paved area, within or at the top and bottom of a stair or ramp, designed to provide turning and maneuvering space for wheelchair users and as a resting place for pedestrians. (ADA term)

**lateral clearance** The distance from the edge of traveled way to a roadside object.

**layered networks** Roadway network arrangement where the objective is to separate modes onto different facilities with planned interconnection locations.

**lead agency** The public agency that has the principal responsibility for carrying out or approving a project.

**left-cross** Describes the intersection conflict between a motor vehicle left-turn and bicycle through movement in the opposing direction.

**legal road approach** A road approach that complies with the requirements of [Chapter 530](#) for limited access facilities and [Chapter 540](#) for managed access facilities.

**length of need** The length of a traffic barrier used to shield a fixed feature.

**level of service (LOS)** LOS is based on peak hour, except where noted. LOS assigns a rank (A – F) to facility sections based on traffic flow concepts like density, delay, and/or corresponding safety performance conditions. (See the Highway Capacity Manual and AASHTO’s Geometric Design of Highways and Streets ["Green Book"] for further details.)

**life cycle cost** The total cost of a project or item over its useful life. This includes all of the relevant costs that occur throughout the life of a project or item, including initial acquisition costs (such as right of way, planning, design, and construction), operation, maintenance, modification, replacement, demolition, financing, taxes, disposal, and salvage value as applicable.

**light emitting diode (LED)** A two-lead semiconductor light source.

**limited access (L/A)** Full, partial, or modified access control is planned and established for each corridor and then acquired as the right to limit access to each individual parcel (see [Chapter 520](#)).

- **acquired limited access control** Access rights have been purchased.
- **established limited access control** An access hearing has been held and the Assistant Secretary, Engineering & Regional Operations, has adopted the findings and order, which establishes the limits and level of control.
- **planned limited access control** Limited access control is planned for some time in the future; however, no access hearing has been held.

**Limited Access and Managed Access Master Plan** A map of Washington State that shows established and planned limited access highways: [www.wsdot.wa.gov/design/accessandhearings](http://www.wsdot.wa.gov/design/accessandhearings)

**limited access highway** All highways listed as “Established L/A” on the Limited Access and Managed Access Master Plan and where the rights of direct access to or from abutting lands have been acquired from the abutting landowners.

- **full access control** This most restrictive level of limited access provides access, using interchanges, for selected public roads/streets only, and prohibits highway intersections at grade.
- **partial access control** The second most restrictive level of limited access. At grade intersections with selected public roads are allowed, and there may be some crossings and some driveway approaches at grade. Direct commercial access is not allowed.

- **modified access control** The least restrictive level of limited access. Characteristics are the same as for partial access control except that direct commercial access is allowed.

**local roads** Non-state highways that are publicly owned.

**long tunnel** A tunnel, lid, or underpass that is greater than 80' in length and has a length to vertical clearance ratio greater than 10:1.

**low pavement type** Bituminous surface treatment (BST).

**lumen** The unit used to measure luminous flux.

**luminaire** A complete lighting unit comprised of a light bulb or light emitting Diode (LED) module, wiring, and a housing unit.

**luminance** The quotient of the luminous flux at an element of the surface surrounding the point and propagated in directions defined by an elementary cone containing the given direction, by the product of the solid angle of the cone and area of the orthogonal projection of the element of the surface on a plane perpendicular to the given direction. The luminous flux may be leaving, passing through, and/or arriving at the surface.

**luminous flux** The time rate of the flow of light.

## M

**M2D2** Multimodal Development and Delivery

**managed access highway** Highways where the rights of direct access to or from abutting lands have not been acquired from the abutting landowners.

**managed lane** A lane that increases efficiency by packaging various operational and design actions. Lane management operations may be adjusted at any time to better match regional goals.

**managing project delivery** A WSDOT management process for project delivery from team initiation through project closing.

**maximum extent feasible (MEF)** From the U.S. Department of Justice, [28 CFR Part 36.402](#), Alterations. The phrase "to the maximum extent feasible" applies to "the occasional case where the nature of an existing facility makes it virtually impossible to comply fully with applicable accessibility standards through a planned alteration." This phrase also refers to a stand-alone piece of design documentation that WSDOT uses to record its reasons for not being able to achieve full ADA compliance in alteration projects (called a Maximum Extent Feasible document). (ADA term)

**maximum uniformity ratio** The average light level within the design area divided by the minimum light level within the design area (see [Chapter 1040](#)).

**maximum veiling luminance ratio** The maximum veiling luminance divided by the average luminance over a given design area for an observer traveling parallel to the roadway centerline (see [Chapter 1040](#)).

***mcd/m<sup>2</sup>/lux*** Pavement marking retroreflectivity is represented by the coefficient of retroreflected luminance ( $R_L$ ) measured in millicandelas per square meter.

***Measures of Effectiveness (MOEs)*** In the context of [Chapter 320](#), examples are: speed, delay, density, LOS, QOS, person or vehicle throughput, cost vs. benefit, and queue. (See FHWA's MOE List.)

***median*** The portion of a divided highway separating vehicular traffic traveling in opposite directions.

***median functions*** one or more reason(s) for a median as described in [Chapter 1239](#).

***median opening*** An opening in a continuous median for the specific purpose of allowing vehicle movement.

***Memorandum of Understanding (MOU) for a road approach permit*** There is a MOU (Highways Over National Forest Lands) between the United States Forest Service (USFS) and WSDOT that requires the USFS to obtain a road approach permit for new access to a state highway that is crossing Forest Service land.

***metering signal*** A signal used to control the predominant flow rate of traffic at an at-grade facility.

***Methods and Assumptions Document*** A mandatory document developed at the beginning of the ARR phase to record ARR assumptions, methodologies, criteria, and decisions (see [Chapter 550](#)).

***Metropolitan Planning Organization (MPO)*** A lead agency designated by the Governor to administer the federally required transportation planning process in a metropolitan area with a population over 50,000. The MPO is responsible for the 20 year long-range plan and Transportation Improvement Program (TIP).

***midblock pedestrian crossing*** A marked pedestrian crossing located between intersections. (ADA term)

***minimum average light level*** The average of all light intensities within the design area, measured just prior to relamping the system (see [Chapter 1040](#)).

***minimum light level*** The minimum light intensity of illumination at any single point within the design area measured just prior to relamping the system (see [Chapter 1040](#)).

***minor arterial system*** A rural network of arterial routes linking cities and other activity centers that generate long distance travel and, with appropriate extensions into and through urban areas, form an integrated network providing interstate and interregional service ([RCW 47.05.021](#)).

***minor operational enhancement projects*** These projects usually originate from the Q2 component of the Q Program and are quick responses to implement low-cost improvements. They are typically narrow in scope and focus on improvements to traffic operations and modifications to traffic control devices. Guidance on the type of work included in the Q subprograms is in the Chart of Accounts.

***modal compatibility*** An assessment to determine which mode(s) need to be considered strictly based on the context characteristics present or planned. The assessment is independent of whether any



particular mode is present on the segment, and intended to guide strategic investment opportunities on a segment.

**modal priority** Mode(s) that will be prioritized when making design decisions for the project, guided by the outcome of the modal compatibility assessment.

**mode** A specific type or form of transportation. Typically for roadway design the modes are: automobiles, transit, truck freight, pedestrians, skateboards, and bicycles.

**monument** As defined in [Chapter 410](#), a monument is any physical object or structure that marks or references a survey point. This includes, but is not limited to, a point of curvature (P.C.), a point of tangency (P.T.), a property corner, a section corner, a General Land Office (GLO) survey point, a Bureau of Land Management (BLM) survey point, and any other permanent reference set by a governmental agency or private surveyor.

**monument removal or destruction** The physical disturbance or covering of a monument such that the survey point is no longer visible or readily accessible.

**mounting height – luminaire** The vertical distance between the surface of the design area and the center of the light source of the luminaire. Note: This is not to be confused with pole height (H1), but is the actual distance that the luminaire is located above the roadway edge line.

**movable bridge signal** (also drawbridge signal) A signal installed to notify traffic to stop when the bridge is opened for waterborne traffic. Movable bridge signals display continuous green when the roadway is open to vehicular traffic.

**multimodal connection** The point where multiple types of transportation activities occur; for example, where transit buses and van pools drop off or pick up passengers (including passengers with bicycles).

## **N**

**National Highway System (NHS)** The NHS was developed by the U.S. Department of Transportation (DOT) in cooperation with the states, local officials, and metropolitan planning organizations (MPOs). The NHS includes the following subsystems of roadways (note that a specific highway route may be on more than one subsystem):

- **Interstate** The Eisenhower Interstate System of highways retains its separate identity within the NHS.
- **Other Principal Arterials** These are highways in rural and urban areas that provide access between an arterial and a major port, airport, public transportation facility, or other intermodal transportation facility.
- **Strategic Highway Network (STRAHNET)** This is a network of highways that are important to the United States' strategic defense policy and that provide defense access, continuity, and emergency capabilities for defense purposes.
- **Major Strategic Highway Network Connectors** These are highways that provide access between major military installations and highways that are part of the Strategic Highway Network.



- **Intermodal Connectors** These highways provide access between major intermodal facilities and the other four subsystems making up the National Highway System.

**natural vehicle path** The natural path that a driver navigates a vehicle given the layout of the intersection and the ultimate destination.

**need** A statement that identifies the transportation problem(s) or other performance gap

**negative illumination** Lighting the background and leaving the object dark to contrast with the light behind it as the driver views it.

**network connectivity** How the various roadways and other transportation facilities within a network interconnect in a defined geographic area.

**nighttime** The period of time from one-half hour after sunset to one-half hour before sunrise and any other time when persons or objects may not be clearly discernible at a distance of 500 feet ([RCW 46.04.200](#)).

**no-build condition** The baseline, plus state transportation plan and comprehensive plan improvements, expected to exist, as applied to the year of opening or the design year.

**nonconforming road approach** A road approach that does not meet current requirements for location, quantity, spacing, sight distance, or geometric elements.

**nonrecoverable slope** A slope on which an errant vehicle might continue until it reaches the bottom, without having the ability to recover control. Fill slopes steeper than 4H:1V, but not steeper than 3H:1V, are considered nonrecoverable.

**nonseparated HOV lane** An HOV lane that is adjacent to and operates in the same direction as the general-purpose lanes with unrestricted access between the HOV lane and the general-purpose lanes.

**notice of appearance** A form provided by WSDOT for anyone wanting to receive a copy of the findings and order and the adopted limited access plan (see [Chapter 210](#)).

**notice of hearing** (or hearing notice) A published advertisement that a public hearing will be held.

**notice of opportunity for a hearing** An advertised offer to hold a public hearing.

## O

**occupancy designation** The minimum number of occupants required for a vehicle to use the HOV facility.

**operating speed** The speed at which drivers are observed operating their vehicles during free flow conditions.

**order of hearing** The official establishment of a hearing date by the Director & State Design Engineer, Development Division.

**outer separation** The area between the outside edge of traveled way for through traffic and the nearest edge of traveled way of a frontage road or collector-distributor (C-D) road.

**overlapped displays** Overlapped displays allow a traffic movement to operate with one or more nonconflicting phases. Most commonly, a minor street's exclusive right-turn phase is overlapped with the nonconflicting major street's left-turn phase. An overlapped display can be terminated after the parent phase (the main phase the overlap is associated with) terminates. An overlapped display programmed for two or more parent phases continues to display until all of the parent phases have terminated. An overlap is made up of two or more phases—not one phase controlling two movements.

## P

**painted nose** The point where the main line and ramp lanes separate.

**passenger loading zone** An area provided for pedestrians to board/disembark a vehicle. (ADA term)

**passing lane** An auxiliary lane on a two-lane highway used to provide the desired frequency of passing zones.

**passing sight distance** The distance (on a two-lane highway) needed for a vehicle driver to execute a normal passing maneuver based on design conditions and design speed.

**pavement marking** A colored marking applied to the pavement by spray, extrusion, adhesives, or glue to provide drivers with guidance and other information.

**pavement marking beads** **Glass:** Small glass spheres used in highway pavement markings to provide retroreflectivity. **Composite:** any non-glass bead intended to provide wet weather retroreflectivity.

**pavement marking durability** A measure of a pavement marking's resistance to wear and deterioration.

**peak hour** The 60-minute interval that contains the largest volume of traffic during a given time period. If a traffic count covers consecutive days, the peak hour can be an average of the highest hour across all of the days. An a.m. peak is simply the highest hour from the a.m., and the p.m. peak is the highest from the p.m. The peak hour correlates to the DHV, but is not the same. However, it is close enough on items such as intersection plans for approval to be considered equivalent.

**pedestrian** Any person afoot or using a wheelchair (manual or motorized) or means of conveyance (other than a bicycle) propelled by human power, such as skates or a skateboard. (ADA term)

**pedestrian access route (PAR)** (synonymous with [accessible route](#)) A continuous, unobstructed walkway within a pedestrian circulation path that provides accessibility. Pedestrian access routes consist of one or more of the following pedestrian facilities: walkways/sidewalks, curb ramps (excluding flares), landings, crosswalks, pedestrian overpasses/underpasses, access ramps, elevators, and platform lifts. Note: Not all transportation facilities need to accommodate pedestrians. However, those that do accommodate pedestrians need to have an accessible route. (ADA term)

**pedestrian circulation path** A prepared exterior or interior way of passage provided for pedestrian travel. Includes independent walkways, shared-use paths, sidewalks, and other types of pedestrian facilities. All pedestrian circulation paths are required to contain a continuous pedestrian access route that connects to all adjacent pedestrian facilities, elements, and spaces that are required to be accessible. (ADA term)

**pedestrian facilities** Walkways such as sidewalks, walking and hiking trails, shared-use paths, pedestrian grade separations, crosswalks, and other improvements provided for the benefit of pedestrian travel. Pedestrian facilities are intended to be accessible routes. (ADA term)

**pedestrian overpass or underpass** A grade-separated pedestrian facility, typically a bridge or tunnel structure over or under a major highway or railroad that allows pedestrians to cross. (ADA term)

**pedestrian refuge island** An island in the roadway that physically separates the directional flow of traffic, provides pedestrians with a place of refuge, and reduces the crossing distance. Note: Islands with cut-through paths are more accessible to persons with disabilities than are raised islands with curb ramps. (ADA term)

**pedestrian signal** An adaptation of a conventional traffic signal installed at established pedestrian crossings. It is used to provide a protected phase for pedestrians by terminating the conflicting vehicular movements to allow for pedestrian crossings. (ADA term)

**performance-based decisions** Decisions that are made based on performance, performance metrics, performance targets, and performance gaps. Also, decisions made using performance evaluation tools, such as [the Highway Safety Manual predictive methods](#) for evaluating safety performance.

**performance category** Any broad area of performance important to an organization, project, or place. WSDOT's six performance categories: Economic Vitality, Preservation, Safety, Mobility, Environment, and Stewardship [are the result of legislative policy per RCW 47.04.280](#).

**performance evaluation tools** Quantitative tools used to measure performance. Examples of these tools currently being used by WSDOT are *Highway Safety Manual* methodology (for safety performance) and *Highway Capacity Manual* (for mobility performance).

**performance gap** The difference between the measured and targeted performance unit for a performance metric. This gap is another way of describing the performance need(s) at a location.

**performance metric** Any measurable indicator used to assess the achievement of outcomes.

**performance need** See [baseline performance need](#) and [contextual performance need](#)

**performance target(s)** An outcome or desired state intended for a project. Performance targets are identified as either baseline or contextual (see [Chapter 1101](#)).

**permit holder** The abutting property owner or other legally authorized person to whom an access connection permit is issued by the permitting authority.

**permitted access connection** A connection for which an access connection permit has been issued by a permitting authority.

**permitting authority** The agency that has legal authority to issue managed access connection permits. For access connections in unincorporated areas, the permitting authority is WSDOT; for access connections within corporate limits, the permitting authority is a city or town.

**person with a disability** Per the U.S. Department of Justice: An individual with a disability is defined by the ADA as a person who has a physical or mental impairment that substantially limits one or more major life activities, a person who has a history or record of such an impairment, or a person who is perceived by others as having such an impairment. It is defined by law through the American with Disabilities Act. (ADA term)

**physical nose** The point, upstream of the gore, with a separation between the roadways of 16 to 22 feet (see [Chapter 1360](#)).

**planning** Transportation planning is a decision-making process required by federal and state law used to solve complex, interrelated transportation and land use problems.

**Planning and Environmental Linkage (PEL)** A collaborative and integrated approach to transportation decision-making that (1) considers environmental, community, and economic goals early in the planning process, and (2) uses the information, analysis, and products developed during planning to inform the environmental review process.

**Plans, Specifications, and Estimates (PS&E)** The project development activity that follows Project Definition and culminates in the completion of contract-ready documents and the engineer's cost estimate.

**pole height (H1)** The vertical distance from the light source to the pole base. This distance is specified in contracts and used by the pole manufacturers to fabricate the light standard.

**portable traffic signal** A type of conventional traffic signal used in work zones to control traffic. This signal is most commonly used on two-way two-lane highways where one lane has been closed for roadwork. This signal is most commonly operated in pairs, with one signal at each end of the work zone. This eliminates the need for 24-hour flagger control. The traffic signal provides alternating right of way assignments for conflicting traffic movements. The signal has an adjustable vertical support with two three-section signal displays and is mounted on a mobile trailer with its own power source.

**positive illumination** Lighting the surface of the object as the driver views it.

**posted speed** The maximum legal speed as posted on a section of highway using regulatory signs.

**Practical Design/Practical Solutions** An approach to making project decisions that focuses on the specific problem the project is intended to address. This performance-based approach looks for lower cost solutions that meet outcomes that WSDOT, partnering agencies, communities and stakeholders have identified. Practical design is a fundamental component to the vision, mission, values, goals, and reforms identified in [Results WSDOT- WSDOT's Strategic Plan](#). With practical solutions, decision-making focuses on maximum benefit to the system, rather than maximum benefit to the project. Focusing on the specific project need minimizes the scope of work for each project so that system-wide needs can be optimized.

**prehearing packet** A concise, organized collection of all necessary prehearing data, prepared by the region and approved by the HQ Access and Hearings Section Manager prior to the hearing (see [Chapter 210](#)).

**preliminary engineering (PE)** A term used to describe the Project Delivery process from project scoping through PS&E review.

**principal arterial system** A connected network of rural arterial routes with appropriate extensions into and through urban areas, including routes designated as part of the Interstate System, that serves corridor movements with travel characteristics indicative of substantial statewide and interstate travel ([RCW 47.05.021](#)).

**Priority Programming Process** The rational selection of projects and services according to factual need and an evaluation of life cycle costs and benefits.

**project** The Project Management Institute defines a project to be "a temporary endeavor undertaken to create a unique product or service."

**Project Definition** (see [Project Summary](#))

**Project Development Approval** Final approval of all project development documents by the designated representative of the approving organization prior to the advertisement of a capital transportation project (see [Chapter 300](#)).

**Project Engineer** This term applies to WSDOT personnel. Wherever "Project Engineer" appears in this manual, the design-builder shall deem it to mean "Engineer of Record."

**Project File (PF)** A file containing all documentation and data for all activities related to a project (see [Chapter 300](#)).

- **Design Documentation Package (DDP)** The portion of the Project File, including Design Approval and Project Development Approval that will be retained long term in accordance with WSDOT document retention policies. Depending on the scope of the project, it contains the Project Summary and some or all of the other documents discussed in [Chapter 300](#). Technical reports and calculations are part of the Project File, but they are not designated as components of the DDP. Include estimates and justifications for decisions made in the DDP (see [Chapter 300](#)). The DDP explains how and why the design was chosen and documents approvals.

**project management plan** A formal, approved document that defines how the project is executed, monitored, and controlled. It may be in summary or detailed form and may be composed of one or more subsidiary management plans and other work planning documents. For further information, see the Project Management Guide:

<http://www.wsdot.wa.gov/Projects/ProjectMgmt/OnlineGuide/ProjectManagementOnlineGuide.htm>

**project need statement** A statement identifying the baseline performance need for the project. For each identified project need, there may be one or more performance metrics, targets, and gaps.

**Project Scoping** See [scoping phase](#).

**Project Summary** A set of documents consisting of the, Environmental Review Summary (ERS), and Project Definition (PD). The Project Summary is part of the design documentation required to obtain Design Approval and is ultimately part of the design documentation required for Project Development Approval (see [Chapter 300](#)).

- **Environmental Review Summary (ERS)** A document that records the environmental classification (class of action) and considerations (consequences of action) for a specific project.
- **Project Definition (PD)** A document that records the purpose and need of the project, along with program level and design constraints.

**Projects of Division Interest (PoDIs)** A primary set of projects for which FHWA determines the need to exercise oversight and approval authority, as described in [Chapter 300](#).

**proposal** The combination of projects/actions selected through the study process to meet a specific transportation system need.

**public art** An enhancement to a functional element, feature, or place within a transportation facility to provide visual interest. The enhancement could be an addition to a functional element, integrated into a design, or for purely aesthetic purposes. An element is considered “public art” if it is beyond WSDOT standard practice for architectural treatment.

**public involvement plan** A plan to collaboratively involve the public in decision making, tailored to the specific needs and conditions of a project and the people and communities it serves. It is often part of a broader communications plan.

**public transportation** Passenger transportation services available to the public, including buses, ferries, rideshare, and rail transit.

**purpose** General project goals such as improve safety, enhance mobility, or enhance economic development.

## Q

**Quality of Service (QOS)** Defined by the *Highway Capacity Manual* or by agreement. Intended to describe how well a facility or service operates or functions from the perspective of the user.

**quantitative safety analysis** An analysis of quantitative safety performance based on data-driven science based tools and techniques that model modal crash potential.

**quantitative tools** Analytical tools used to measure performance. Examples of tools currently being used by WSDOT are:

- *Highway Safety Manual* predictive methods (for safety performance)
  - o AASHTOWare SafetyAnalyst
  - o ISATe (spreadsheet tool for implementing the HSM predictive methods for freeways and interchanges)
  - o IHSDM (FHWA software tool for implementing the HSM predictive methods)

- o HSM Enhanced Spread Sheets ([spreadsheet tools for implementing the HSM predictive methods for rural two lane two way roadways, rural multilane roads, and urban and suburban arterials](#))
- o See also <http://wwwi.wsdot.wa.gov/highwaysafety>
- *Highway Capacity Manual* (for mobility performance)

**queue cutter traffic signal** A traffic signal used at highway-rail grade crossings where the queue from a downstream traffic signal is expected to extend within the Minimum Track Clearance Distance. It is used to keep vehicles from an adjacent signalized intersection from queuing on the railroad tracks.

## R

**raised median** A raised island in the center of a road used to restrict vehicle left turns and side street access. Note: Islands with cut-through paths are more accessible to persons with disabilities than are raised islands with curb ramps. (ADA term)

**ramp** A walking surface with a running slope steeper than 20H:1V (5%). (ADA term)

**ramp** (in relation to a [Roadway](#)) A short roadway connecting a main lane of a highway with another facility, such as a road, parking lot, or transit stop, for vehicular use.

**ramp connection** The pavement at the end of a ramp, connecting to a main lane of a roadway.

**ramp meter** A traffic signal at a freeway entrance ramp that allows a measured or regulated amount of traffic to enter the freeway.

**ramp terminal** An intersection at the end of a ramp.

**Record of Decision (ROD)** Under the National Environmental Policy Act, the Record of Decision accompanies the Final Environmental Impact Statement; explains the reasons for the project decision; discusses alternatives and values considered in selection of the preferred alternative; and summarizes mitigation measures and commitments that will be incorporated in the project.

**recoverable slope** A slope on which the driver of an errant vehicle can regain control of the vehicle. Slopes of 4H:1V or flatter are considered recoverable.

**recovery area** The minimum target value used in highway design when a fill slope between 4H:1V and 3H:1V starts within the Design Clear Zone.

**Recreational Vehicle Account** In 1980 the RV account was established for use by the department of transportation for the construction, maintenance, and operation of recreational vehicle sanitary disposal systems at safety rest areas ([RCW 46.68.170](#)). A recreational vehicle sanitary disposal fee is required for registration of a recreational vehicle ([RCW 46.17.375](#)). Adjustments to the recreational vehicle fee by the department of transportation may be implemented after consultation with the citizens' representatives of the recreational vehicle user community ([RCW 47.01.460](#)).



**Regional Transportation Planning Organization (RTPO)** A planning organization authorized by the Legislature in 1990 as part of the Growth Management Act. The RTPO is a voluntary organization with representatives from state and local governments that are responsible for coordinating transportation planning activities within a region.

**relocation assistance program** A program that establishes uniform procedures for relocation assistance that will ensure legal entitlements and provide fair, equitable, and consistent treatment to persons displaced by WSDOT-administered projects, as defined in the [Right of Way Manual](#).

**Request for Proposal (RFP)** The document package issued by WSDOT requesting submittal of proposals for the project and providing information relevant to the preparation and submittal of proposals, including the instructions to proposers, contract documents, bidding procedures, and reference documents.

**rest area** An area to the side of a path.

**résumé** An official notification of action taken by WSDOT following adoption of a findings and order (see [Chapter 210](#)).

**retroreflection** The phenomenon of light rays striking a surface and being returned directly back to the source of light.

**Retroreflection, coefficient of ( $R_L$ )** A measure of retroreflection.

**retroreflectometer** An instrument used to measure retroreflectivity.

**right-hook** Potential intersection conflicts between motor vehicles making a right turn and the bicycle through movement.

**right of way (R/W)** A general term denoting land or interest therein, acquired for or designated for transportation purposes. More specifically, lands that have been dedicated for public transportation purposes or land in which WSDOT, a county, or a municipality owns the fee simple title, has an easement devoted to or required for use as a public road/street and appurtenant facilities, or has established ownership by prescriptive right.

**right of way and limited access plan (R/W and L/A plan)** A right of way plan that also shows limited access control details.

**road approach** An access point, other than a public road/street, that allows access to or from a limited access highway on the state highway system.

**roadside park** A roadside user facility for safe vehicular parking off the traveled way and separated from the highway by some form of buffer. These sites might be equipped with features or elements such as points of interest, picnic tables, and/or vault toilet buildings. Unlike a safety rest area, a roadside park does not always provide a permanent restroom building.

**roadway** The portion of a highway, including shoulders.



**roadway luminance** The light projected from a luminaire that travels toward a given area, represented by a point on the pavement surface, and then back toward the observer, opposite to the direction of travel. The units of roadway luminance are footcandles.

**roundabout** A circular intersection at grade with yield control of all entering traffic, channelized approaches with raised splitter islands, counter-clockwise circulation, and appropriate geometric curvature to force travel speeds on the circulating roadway generally to less than 25 mph.

**rumble strips** Rumble strips are grooves or rows of raised pavement markers placed perpendicular to the direction of travel, or ground in a continuous longitudinal sinusoidal pattern. They are used to alert inattentive drivers.

**running slope** A slope measured in the direction of travel, normally expressed as a percent. (ADA term)

## S

**Safety Analyst** A program developed to implement the *Highway Safety Manual* methodology

**safety rest area (SRA)** A roadside facility equipped with permanent restroom building(s), a parking area, picnic tables, refuse receptacles, illumination, and other ancillary services. SRAs typically include potable water and might include traveler information and telephones.

**Safety Rest Area Strategic Plan** Developed in 2008 under a stakeholder-coordinated effort of executive and advisory team members, this plan provides guidance for current and future management of the SRA program.

**sawtooth berth** A series of bays that are offset from one another by connecting curb lines, constructed at an angle from the bus bays. This configuration minimizes the amount of space needed for vehicle pull in and pull out.

**scoping phase** An initial phase of project development for a specific project. The scoping phase precedes the design and/or preliminary engineering phase and is intended to support priority programming and budget building scenarios. The [Project Summary](#) is the documentation developed during this phase.

**security lighting** A minimal amount of lighting used to illuminate areas for public safety or theft reduction. Security lighting for walkways is the lighting of areas where shadows and horizontal and vertical geometry obstruct a pedestrian's view.

**separated HOV facility** An HOV roadway that is physically separated from adjacent general-purpose lanes by a barrier or median, or is on a separate right of way.

**shared-use landing** A level (0 to 2% grade cross slope and running slope) paved area within the shared-use path, designed to provide turning and maneuvering space for wheelchair users and as a resting place for pedestrians.

**shared-use path** A facility physically separated from motorized vehicular traffic within the highway right of way or on an exclusive right of way with minimal crossflow by motor vehicles. Shared-use paths

are primarily used by bicyclists and pedestrians, including joggers, skaters, and pedestrians with disabilities, including those who use nonmotorized or motorized wheeled mobility devices. With appropriate design considerations, equestrians may also be accommodated by a shared-use path facility.

**short tunnel** A tunnel, lid, or underpass that is shorter than 80' in length and has a length to vertical clearance ratio of 10:1 or less.

**shoulder** The portion of the roadway contiguous with the traveled way, primarily for accommodation of stopped vehicles, emergency use, lateral support of the traveled way, and where allowed, use by pedestrians and bicycles.

**shoulder width** The lateral dimension of the shoulder, measured from the edge of traveled way to the edge of roadway or the face of curb.

**sidewalk** A walkway along a highway, road, or street intended for use by pedestrians. (ADA term)

**sight distance** The length of highway visible to a driver.

**Signal Maintenance Management System (SIMMS)** A database used for traffic signals, illumination, and Intelligent Transportation Systems (ITS). SIMMS is used to establish an inventory base, enter work reports, print timesheets, and store maintenance records for electrical/electronic systems within WSDOT right of way.

**single-lane roundabout** A roundabout having single-lane entries at all legs and one circulating lane.

**single-occupant vehicle (SOV)** Any motor vehicle other than a motorcycle carrying one occupant.

**site** Parcel(s) of land bounded by a property line or a designated portion of a public right of way. (ADA term)

**site design** Style and configuration of the built environment or parcel(s).

**slip base** A mechanical base designed to allow the light standard to break away from the fixed foundation when hit by a vehicle traveling at the design speed and traveling at a departure angle less than or equal to the design departure angle.

**slip lane** A lane that separates heavy right-turn movements from the roundabout circulating traffic (see [Chapter 1320](#)).

**slip ramp** A connection between legs of an intersection that allows right-turning vehicles to bypass the intersection or a connection between an expressway and a parallel frontage road. These are often separated by an island.

**slow-moving vehicle turnout** A shoulder area widened to provide room for a slow-moving vehicle to pull out of the through traffic, allow vehicles to pass, and then return to the through lane.

**speed** The operations or target or posted speed of a roadway. There are three classifications of speed established:

- **Low speed** is considered 35 mph and below.
- **Intermediate speed** is considered 40-45 mph.
- **High speed** is considered 50 mph and above.

**speed limit sign beacon** A beacon installed with a fixed or variable speed limit sign. The preferred display is two flashing yellow indications.

**speed management** An engineered effort to achieve a targeted speed.

**speed transition segment** An engineered segment of road intended to lower the operating speed between contexts with different target speeds.

**splitter island** The raised island at each two-way leg between entering and exiting vehicles, designed primarily to control the entry and exit speeds by providing deflection. They also discourage wrong-way movements, and provide pedestrian refuge.

**state highway system** All roads, streets, and highways designated as state routes in compliance with [RCW 47.17](#).

**static scale** A scale that requires a vehicle to stop for weighing.

**stopping sight distance** The distance needed for a driver to stop a vehicle traveling at design speed based on design conditions.

**stop sign beacon** A beacon installed above a stop sign. The display is a flashing red indication.

**street furniture** Sidewalk equipment or furnishings, including garbage cans, benches, parking meters, and telephone booths. (ADA term)

**streetside** The portion of the public right of way dedicated to the pedestrian thoroughfare and supporting the accessibility, activities and functions of the local land use. The streetside is comprised of a frontage zone, pedestrian zone and furnishing zone (see [Chapter 1238](#)). Note some local agencies may divide the streetside zone.

**study area** The transportation system area to study in the study process and for an [ARR](#). The study area is a minimum of one interchange upstream and downstream from the proposal. The study area shall also include the intersecting roadway in the area to the extent necessary to ensure its ability to collect and distribute traffic to and from the interchange. The study area should be expanded as necessary to capture operational impacts of adjacent interchanges in the vicinity that are, or will be, bottlenecks or chokepoints that influence the operations of the study interchange.

**study plan** A term associated with environmental procedures, this plan proposes an outline or “road map” of the environmental process to be followed during the development of a project that requires complex NEPA documentation (see [Chapter 210](#) and the [Environmental Manual](#)).

**subject matter expert** A person who is an authority in a particular area or topic, and understands the data and the limitations on the use and application of the data.

**superelevation** The rotation of the roadway cross section in such a manner as to overcome part of the centrifugal force that acts on a vehicle traversing a curve.

**superelevation runoff** The length of highway needed to accomplish the change in cross slope from a section with adverse crown removed (level) to a fully superelevated section, or vice versa.

**superelevation transition length** The length of highway needed to change the cross slope from normal crown or normal pavement slope to full superelevation.

**support team** An integral part of the ARR process consisting of an assemblage of people from the regions, FHWA (for Interstates), WSDOT HQ Access and Hearings, and other representatives organized to develop and analyze alternatives to meet the need of a proposal, including approval authorities.

**Surface Transportation Program (STP)** A federal program established by Congress in 1991 that provides a source of federal funding for highway and bridge projects.

## T

**tangent runoff** The length of highway needed to change the cross slope from normal crown to a section with adverse crown removed (level).

**target speed** A proactive approach to establishing a speed consistent with the context characteristics. Target speed is the design operating speed, which aligns design, posted and operating speed as the same value.

**temporary traffic signal** A conventional traffic signal used during construction to control traffic at an intersection while a permanent signal system is being constructed. A temporary traffic signal is typically an inexpensive span-wire installation using timber strain poles.

**tradeoffs analysis** An analysis method for balancing factors, performance or outcomes, which are not attainable at the same time.

**traffic barrier** A longitudinal barrier, including bridge rail or an impact attenuator, used to redirect vehicles from fixed features located within an established Design Clear Zone, help mitigate median crossovers, reduce the potential for errant vehicles to travel over the side of a bridge structure, or (occasionally) protect workers, pedestrians, or bicyclists from vehicular traffic.

**traffic barrier/longitudinal barrier** A device oriented parallel or nearly parallel to the roadway whose primary function is to contain or safely redirect errant vehicles away from fixed features or to (occasionally) protect workers, pedestrians, or bicyclists from vehicular traffic. Beam guardrail, cable barrier, bridge rail, concrete barrier, and impact attenuators are barriers, and they are categorized as rigid, rigid anchored, unrestrained rigid, semirigid, and flexible. They can be installed as roadside or median barriers.

**traffic calming** Design techniques that have been shown to reduce traffic speeds and unsafe maneuvers. These techniques can be stand-alone or used in combination, and they include lane narrowing, curb extensions, surface variations, and visual clues in the vertical plane. (ADA term)

**traffic calming treatments** Treatments along the roadway that can be used to reduce speeds through a section of roadway (see [Chapter 1103](#)).

**Traffic Impact Analysis (TIA)** (sometimes called *Traffic Impact Study (TIS)*) If a traffic analysis is not an ARR it is a TIA. TIAs are used for environmental reviews and developer projects (see [Chapter 320](#)).

**transit** A general term applied to passenger rail and bus service used by the public.

**transit facility** A capital facility that improves the efficiency of public transportation or encourages the use of public transportation.

**transit flyer stop** A multimodal connection located within the boundaries of a limited access facility.

**transition** A section of barrier used to produce the gradual stiffening of a flexible or semirigid barrier as it connects to a more rigid barrier or fixed object.

**transitional segments** Segments of a pedestrian circulation path that blend between existing undisturbed pedestrian facilities and newly altered pedestrian facilities. Use of transitional segments may permit the work of the alteration to more nearly meet the new construction standards. At a later time, when other segments of the pedestrian circulation path are altered, the noncomplying transitional segments can be removed and replaced with pedestrian facilities that meet the accessibility criteria. (ADA term)

**transit lane** A lane for the exclusive use of transit vehicles.

**transit stop** A facility for loading and unloading passengers that is set aside for the use of transit vehicles only.

**transit vehicle** A bus or other motor vehicle that provides public transportation (usually operated by a public agency).

**Transportation Management Area (TMA)** Urbanized areas with populations of 200,000 or greater are federally designated as Transportation Management Areas.

**transportation management plan (TMP)** A set of traffic control plans, transportation operations plans, and public information strategies for managing the work zone impacts of a project. A TMP is required for all projects to address work zone safety and mobility impacts.

**travel demand** The demand travelers will make on the system based on the number and types of trips they will take and the mode and routes they will use. Local travel demand represents short trips that should be made on the local transportation system, such as intracity roads and streets. Regional travel demand represents long trips that are made on the regional transportation system, such as Interstate, regional, and/or intercity/interregional roads, streets, or highways.

**traveled way** The portion of the roadway intended for the movement of vehicles, exclusive of shoulders and lanes for parking, turning, and storage for turning.

**traveled way zone** The portion of the roadway intended for the movement of people and goods, exclusive of shoulders, roadsides, on-street parking, medians and streetside zones.

**traveler information** Commercial and noncommercial information that informs and orients the traveling public. This includes access information for food, gas, lodging, local attractions, regional tourist attractions, roadway conditions, and construction schedules.

**traveling public** Motorists, motorcyclists, bicyclists, pedestrians, and pedestrians with disabilities.

**trips** Short trips are normally local. Long trips are normally interstate, regional, or interregional.

**truck apron** The optional mountable portion of the central island of a roundabout between the raised nontraversable area of the central island and the circulating roadway (see [Chapter 1320](#)).

**turning radius** The radius that the front wheel of the intersection design vehicle on the outside of the curve travels while making a turn (see [Chapter 1320](#)).

**turning roadway** A curve on an open highway, a ramp, or the connecting portion of the roadway between two intersecting legs of an intersection.

**two-way left-turn lane (TWLTL)** A lane, located between opposing lanes of traffic, to be used by vehicles making left turns from either direction, from or onto the roadway.

## U

**undivided multilane** A roadway with two or more through lanes in each direction on which left turns are not controlled.

**uniformity ratio** The ratio of the minimum average light level on the design area to the minimum light level of the same area (see [Chapter 1040](#)).

**universal access** Access for all persons regardless of ability or stature. (ADA term)

**urban area** An area designated by the Washington State Department of Transportation (WSDOT) in cooperation with the Transportation Improvement Board (TIB) and Regional Transportation Planning Organizations (RTPO), subject to the approval of the Federal Highway Administration (FHWA).

**urbanized area** An urban area with a population of 50,000 or more.

**usable shoulder** The width of the shoulder that can be used by a vehicle for stopping.

---

**V**

**validation** A process to confirm the reasonableness, accuracy and completeness of estimated costs and quantities.

**Value Engineering (VE) Analysis** A systematic approach to identifying and removing unnecessary costs which do not contribute to a desired result by analyzing cost versus function.

**Value Engineering Change Proposal (VECP)** A construction contract change proposal submitted by the construction contractor based on a VECP provision in the contract. The intent of these types of proposals is to (1) improve the project's performance, value, and/or quality, (2) lower construction costs, or (3) shorten the delivery time, while considering their impacts on the project's overall life-cycle cost and other applicable factors.

**Value Engineering (VE) Job Plan** A systematic and structured action plan (see [Chapter 310](#)) for conducting and documenting the results of the VE analysis. While each VE analysis shall address each phase in the VE Job Plan, the level of analysis conducted and effort expended for each phase should be scaled to meet the needs of each individual project. The WSDOT VE analysis uses the Seven-Phase Job Plan shown in Exhibit 310-1.

**veiling luminance** The stray light produced within the eye by light sources produces a veiling luminance that is superimposed on the retinal image of the objects being observed. This stray light alters the apparent brightness of an object within the visual field and the background against which it is viewed, thereby impairing the ability of the driver to perform visual tasks. Conceptually, veiling luminance is the light that travels directly from the luminaire to the observer's eye.

**viewpoint** A roadside stopping opportunity with a view of some point of interest or area scenery. This area is not typically separated from the traveled way by some form of highway buffer.

**violation rate** The total number of violators divided by the total number of vehicles on an HOV facility.

**visioning exercises** a process of determining the goals for a facility or place.

**Visitor Information Center (VIC)** A staffed or nonstaffed booth or separate building that displays and dispenses free tourist travel maps and brochures. These are typically located at border-entry SRAs to provide travel information to highway users as they enter the state.

**W**

**walk interval** That phase of a traffic signal cycle during which the pedestrian is to begin crossing, typically indicated by a WALK message or the walking person symbol and its audible equivalent. (ADA term)

**walkway** The continuous portion of the pedestrian access route that is connected to street crossings by curb ramps. (ADA term)

**warning beacon** A beacon that supplements a warning or regulatory sign or marking. The display is a flashing yellow indication. These beacons are not used with STOP, YIELD, or DO NOT ENTER signs or at intersections that control two or more lanes of travel. A warning identification beacon is energized only during those times when the warning or regulation is in effect.

**warrant** A minimum condition for which an action is authorized. Meeting a warrant does not attest to the existence of a condition that needs attention. Further justification is required.

**Washington Transportation Plan (WTP)** A WSDOT planning document developed in coordination with local governments, regional agencies, and private transportation providers. The WTP addresses the future of transportation facilities owned and operated by the state as well as those the state does not own but in which it has an interest. It identifies needed transportation investments, which are defined by service objectives and specific desired outcomes for each transportation mode.

**weaving section** A length of highway over which one-way traffic streams cross by merging and diverging maneuvers.

**weigh in motion (WIM)** A scale facility capable of weighing a vehicle without the vehicle stopping.

**wet film thickness** Thickness of a pavement marking at the time of application without beads.

**work zone** An area of a highway with construction, maintenance, or utility work activities. A work zone is identified by the placement of temporary traffic control devices that may include signs, channelizing devices, barriers, pavement markings, and/or work vehicles with warning lights. It extends from the first warning sign or high-intensity rotating, flashing, oscillating, or strobe lights on a vehicle to the END ROAD WORK sign or the last temporary traffic control device ([MUTCD](#)).

**work zone impact** Highway construction, maintenance, or utility work operations in the traveled way, adjacent to the traveled way, or within the highway's right of way that creates safety and mobility concerns for workers or the traveling public.

**work zone traffic control** The planning, design, and preparation of contract documents for the modification of traffic patterns due to work zone impacts.

**wye (Y) connection** An intersecting one-way roadway, intersecting at an angle less than 60°, in the general form of a "Y."

## Y

**yield-at-entry** The requirement that vehicles on all entry lanes yield to vehicles within the circulating roadway.

**yield point** The point at which entering traffic must yield to circulating traffic before entering the circulating roadway (see [Chapter 1320](#)).

## Z