

Operations and Maintenance Manual Pavement Test Track Instrumentation System

WA-RD 78.2

Final
February 1985



Washington State Department of Transportation
Planning, Research and Public Transportation Division
In Cooperation With
United States Department of Transportation
Federal Highway Administration

1. Report No. WA-RD-78.2		2. Government Accession No.		3. Recipient's Catalog No.	
4. Title and Subtitle Operations and Maintenance Manual Pavement Test Track Instrumentation System				5. Report Date February, 1985	
				6. Performing Organization Code	
7. Author(s) Derald Christensen				8. Performing Organization Report No.	
9. Performing Organization Name and Address University of Washington Civil Engineering Department Seattle, WA 98195				10. Work Unit No.	
				11. Contract or Grant No.	
12. Sponsoring Agency Name and Address Washington State Department of Transportation Highway Administration Building Olympia, WA 98504				13. Type of Report and Period Covered Final Report	
				14. Sponsoring Agency Code	
15. Supplementary Notes Conducted in cooperation with the U.S. Department of Transportation Federal Highway Administration.					
16. Abstract <p>Several pieces of electronic hardware, obtained through previous test efforts have been assembled for laboratory and field use. The equipment consists of two instrument racks. The first contains five Bison inductance type soil strain gage instruments and the associated phase and amplitude controls and solid state switching hardware for switching these controls between sixteen measurement test sections.</p> <p>The second rack contains switch hardware for switching the actual input leads for the individual inductance coils associated with the sixteen test section. It also contains the necessary data acquisition and analysis hardware.</p>					
17. Key Words Pavement Management, Automated pavement Survey Equipment, Pavement Surface Con- dition Survey				18. Distribution Statement	
19. Security Classif. (of this report) Unclassified		20. Security Classif. (of this page) Unclassified		21. No. of Pages 196	22. Price

The contents of this report reflect the views of the authors who are responsible for the facts and the accuracy of the data presented herein. The contents do not necessarily reflect the official views or policies of the Washington State Department of Highways or the Federal Highway Administration. This report does not constitute a standard, specification, or regulation.

TABLE OF CONTENTS

	Page
I	GENERAL INFORMATION
1.1	Introduction 6
1.2	Supplies and Accessories 8
1.3	Specification 9
II	INSTALLATION
2.1	General 14
2.2	Power Requirements 15
2.3	Signal Connections 15
2.4	Induction Coils 15
2.5	Extensometer & Three Dimensional Array. 16
III	OPERATION
3.1	General 18
3.2	Front Panel Controls 18
3.3	Rear Panel 20
3.4	Bison Instrument 21
3.5	Nicolet Digital Oscilloscope 24
3.6	Signal Conditioning 26
IV	MAINTENANCE
4.1	General 27
4.2	Bison Instrument 27
4.3	Switching Units 28
4.4	Digital Readouts 28
4.5	Nicolet Oscilloscope 28
V	CALIBRATION
5.1	General 29
5.2	Test Equipment Required 29
5.3	Procedure 29
VI	THEORY OF OPERATION
6.1	General 34
6.2	Bison Gage 34
6.3	Secondary Amplitude and Phase Adj 36
6.4	Switching Network 37
6.5	Optional Signal Conditioning 38
6.6	Transducer Inputs 38
6.7	Three Dimensional Transducer Array ... 39
6.8	Nicolet Digital Oscilloscope 39

VII SCHEMATICS, DRAWINGS AND FIGURES

7.1	General	41
7.2	List of Figures	41

VIII APPENDICES

A.	Extensometer Details	82
B.	Nicolet Software Interfaces	
	Nicolet - IBM-PC	86
	Nicolet - VAX 11/750	91
C.	Bison Instrument Manual	110
D.	Nicolet Instrument Manuals	111

LIST OF FIGURES

Figure 1	- Field Installation - WSU Test Track	42
Figure 2	- Instrument Racks - Front and Rear Panels	43
Figure 3	- Bison Gages - Front and Rear Panel	44
Figure 4	- Interconnect Diagram for Instrument Racks	45
Figure 5	- Bison Instrument Rack - Mounting Detail	46
Figure 6	- Relay and Coil Input Board Details	47
Figure 7	- Bison Gage Inner connect for Three Dimensional Coil Arrangement	48
Figure 8	- Circuit Board Components Layout and Parts List	49
Figure 9	- Switching Circuit and Control Diagram	50
Figure 10	- Remote Control Circuit Diagram	51
Figure 11	- Nicolet Plug-in Amplifier Unit	52
Figure 12	- Nicolet Mainframe	53
Figure 13	- Nicolet Disk Recorder	54
Figure 14	- Nicolet Input/Output Panel	55
Figure 15	- Bison Calibration Jig - Adjustable	56
Figure 16	- Bison Calibration Jig - Stationary	57
Figure 17	- Bison Calib - Spacing vs Ampl - 1" Coils Parallel ..	58
Figure 18	- Bison Calib - Spacing vs Ampl - 2" Coils Parallel ..	59
Figure 19	- Bison Calib - Spacing vs Ampl - 2" Coils Coplanar ..	60
Figure 20	- Bison Calib - Spacing vs Ampl - 4" Coils Parallel ..	61
Figure 21	- Bison Calib - Spacing vs Ampl - 4" Coils Coplanar ..	62
Figure 22	- Bison Calib - Spacing vs Volts - 1" Coils Parallel .	63
Figure 23	- Bison Calib - Spacing vs Volts - 1" Coils Coplanar .	64
Figure 24	- Bison Calib - Spacing vs Volts - 2" Coils Parallel .	65
Figure 25	- Bison Calib - Spacing vs Volts - 2" Coils Coplanar .	66
Figure 26	- Bison Calib - spacing vs Volts - 4" Coils Parallel .	67
Figure 27	- Bison Calib - Spacing vs Volts - 4" Coils Coplanar .	68
Figure 28	- Bison Calib - k' vs Calib Signal 1" Coils	69
Figure 29	- Bison Calib - k' vs Calib signal 2" Coils	70
Figure 30	- Bison Calib - k' vs Calib Signal 4" Coils	71
Figure 31	- Bison Calib - Regression Equations	72
Figure 32	- Suggested Signal Conditioning Electronics	76
Figure 33	- Alternative Application for Induction Coils	77
Figure 34	- Alternative Application for Induction Coils	78
Figure 35	- Photograph of Inductance Coils	79
Figure 1A	- Extensometer - General Detail	82
Figure 2A	- Extensometer - Bison Coil Sensor Detail	83
Figure 3A	- Extensometer - End Plate and Guide Detail	84

SECTION I
GENERAL INFORMATION

1.1 Introduction

Several pieces of electronic hardware, obtained through previous test efforts at Washington State University's (WSU) pavement test track, have been acquired by Washington State Department of Transportation. An effective effort to tie these items, along with a separate data acquisition system, into a single monitoring system was undertaken in a previous WSDOT funded project (Y2718).

The instrumentation package developed for the WSU test track is made up of two instrument racks (see Figure 2). The first rack (Bison Instrument Rack) contains five inductance coil type soil strain instruments (Bison Instrument Corporation, Model 4101A). These instruments are packaged with individual switching and balancing hardware for each instrument at each measurement station. This allows them to be switched between sixteen different measuring locations.

The second rack (Read Out and Control Rack) contains the main controls, signal conditioning electronics, read out displays and data acquisition system. The complete instrument system can be switched between sixteen measuring stations. Each station can contain the five Bison soil strain instruments, in any desired configuration, plus six independent transducers. The independent transducers can be of any type including foil strain gages,

DCDT's and/or pressure sensors. Two card racks are set up for signal conditioning for up to 96 of these input transducers, but no electronics are provided (See Figures 2, 6 and 32 for details of the signal conditioning card option). Also, a separate switching and read out display is included for up to sixteen temperature sensor. Ten inductance coil type sixteen foot long extensometers are also included with the system.

The data acquisition system, which is connected to the individual inputs through front panel BNC connectors, consist of a two channel digital oscilloscope with CRT graphics display, internal memory and floppy disk storage. The system is extremely flexible and can operate as a single stand alone piece of equipment or can be used as a front end to any existing mini or microcomputer. It can also be used with off the shelf x-y and or HP 7470 digital plotter to further enhance its stand alone or remotely controlled data acquisition capabilities.

A digital panel meter is also located on the front panel to enhance individual read outs of the different outputs. All signals are available at the front panel and can easily be interfaced to any other desired measuring and/or read out equipment. Also, all switching and balancing hardware has been designed to be controlled remotely via a separate control system or computer. This will require minor hardware modifications and a competent electronics technician.

The intended mode of operation would be to manually switch the instruments between the different measuring stations on the

test track. Each measuring station could contain up to five inductance coil type strain measurements plus up to an additional six sensors of any desired type. These signals would be measured and displayed on the digital scope and analyzed, stored and plotted. The scope allows for easy horizontal and vertical scale expansion, peak and time spread measurements along with signal averaging, differentiation, integration and even frequency domain analysis. All plots can be displayed, labeled and stored. Also, up to sixteen temperature sensors can be located around the track. These outputs are monitored manually. The temperature sensors are a constant current type unit and are manufactured by Analog Devices (P/N AD590).

This operations and maintenance manual along with the individual manufacturers equipment manuals includes all the information required to set up, install and operate an experiment at the WSU test track as well as at another test site or laboratory experimentation that may require all or any portion of this monitoring equipment.

1.2 Supplies and Accessories

The only supplies required are the bison coils, which can be ordered directly from Bison Instruments Corporation in Minneapolis, MN. And the floppy disks used in the Nicolet scope, which are double sided, double density, soft sector, 40 track diskettes. Xidex or Dysan are recommended manufacturers.

1.3 Specification

Bison Instrument - Model 4101A Soil Strain Gage

Sensor size:

1/2 - inch diameter by 1/8 - inch thick
1-1/8 - inch diameter by 1/8 - inch thick
2-1/8 - inch diameter by 1/4 - inch thick
4-1/8 - inch diameter by 1/4 - inch thick

Sensor bodies are machined linen phenolic base forms with coils potted in epoxy for environmental stability. Other size sensor are available on special order.

Excitation Characteristics:

Frequency = 20 khz.
Amplitude = 15 volts peak-to-peak.
Total harmonic distortion = 0.3%.
Short term frequency stability is $\pm 0.1\%$ (1 hour period under any load). Provision is provided for external oscillator.
Impedance is greater than 2 kohms.

Response Time:

For step input, 0.25 msec. with 2% maximum overshoot and no ringing. Low frequency response is d.c. with good long term stability.

Output Voltage:

Output of ± 5 volts will correspond to full scale meter deflection. Output continues linear to ± 10 volts for recorders. Output impedance to recorder is 50 ohms and output is short circuit protected.

Maximum Sensitivity:

0.1 percent strain per volt, or based on 1-inch sensor, in terms of spacing change is
0.00012 inch movement per volt, or
0.0004 inch movement per amplitude dial division.

Resolution:

Infinite on recorder output.
Limited to 0.01 per cent strain on the meter and to 0.04 percent strain on the Amplitude dial.

Temperature:

Operating temperature is 0 to 70 degrees C ambient.
Temperature error on electronics is 10mv/1 degree C
at maximum sensitivity.
Storage temperature is -55 to +85 degrees C.

Signal to noise ratio: 50 to 1

Cable length:

Cables normally should be 0 to 1000 ft long, but can be longer if desired. Output and strain measurements are independent of changes in cable length and cable characteristics due to temperature, time pressure and moisture.

Power Supply:

Self-contained rechargeable +- 12 volt 1.2 AH battery pack operation. External 110/220 volt - 50/60 hz charger. Instrument may be operated continuously with the charger cord plugged into bench supply. Charging rate is 0.12 amps.

Circuitry:

Integrated circuits together with individual silicon semiconductors securely mounted on 5 plug-in glass epoxy circuit boards.

Readouts:

Panel mounted meter -100 to 0 to 100 scale. Digital readouts 0 to 10,000.

Case:

Bison designed high impact ABS case, weatherproof and operable in any position.

Dimensions:

10"x6.5"x12"

Weight:

10 lb

Nicolet Instrument Corporation - Model 4094 Digital Oscilloscope.

Mainframe:

Memory size:

16K words, 17bits.

Addressable Subgroups:

Halves (8K), quarters(4K).

Data Memory:

31/32 of Memory Size.

Storage Capacity:

Up to 32 Waveforms.

Display:

6 inch, high definition.

Expansion:

Up to X256, both axes, cursor-interactive.

Numerics:

Time and voltage plus channel number(YT)
Voltage and voltage plus channel number(XY)

Numeric Displays(YTorXY):

Normal (absolute numerics)
Reset Numerics (Relative numerics)
Grid (Numeric scale per grid mark)

Arithmetic Function:

Subtract, Invert, Data Move.

Optional Functions:

Disk Expandable.

Other Standard Functions:

Autocenter:

Automatic lock of cursor to data(unexpanded)
Automatic data centering(expanded).

Zero(Spring Loaded):

Automatic check of analog Zero.

Pen:

Analog output to XY or YT pen recorder.
Output to digital plotter(if connected).

Disk Recorder

Disk Recorder Type:

5-1/4" Floppy, double sided, double density,
soft sectored. Storage capacity/diskette:
twenty 16K, forty 8K or eighty 4K records.

Record Identification:

3-digit L.E.D.

Write Protection:

Automatic, manual unprotect.

Autocycle:

Automatic consecutive capture-and-store of up to
80 records.

Digital I/O

Interfaces Included:

IEEE-488(GPIB), RS232c, disk controller,
digital plotter controller.

IEEE-488(GPIB):

Bi-directional up to 20K bytes/second, ASCII
or binary.

RS-232C:

Bi-directional up to 19,200 baud, ASCII or printable
binary.

Minimum Transfer Times(16K):

GPIB ASCII, 4.5 seconds. GPIB binary
1.5 seconds. RS-232C ASCII, 55 seconds. RS-232C
binary, 18 seconds.

Overall Dimensions:

Mainframe:

43.1 cm (W) x 25.1 cm (H) x 47.2 cm (D).
30 lbs.

Plug-In Model 4562

Inputs:	Two differential
Input Coupling:	AC/DC/GND
Input Impedance:	1M ohm/47pf
Input Filter(Switchable):	100kHz, RC
Input Range(Full Scale):	+/-100mV to +/-40V
Zero Position Control:	10% - 90% F.S.
Safe Overload:	
+/-10V to +/-40V	400V
+/-1V to +/- 4V	300V
+/-100mV to +/- 400mV	300V
Analog Bandwidth:	
+/-1V to +/-40V Range:	1MHz
+/-100mV to +/-400mV Range	400kHz
Common Mode Rejection Ratio:	90dB
Common Mode Voltage Range:	200% F.S.
Maximum Digitizing Rate:	2MHz(500ns/pt)
Minimum Digitizing Rate:	200sec/pt
Vertical Resolution:	12 bits(0.025%)
Horizontal resolution:	15,872:1
Buffer Memory Size:	16K X 16 bits
Accuracy:	0.2% F.S.
Linearity:	0.1% F.S.
Noise, RMS	0.02%F.S.
Sample Time Uncertainty:	+/-1ns
Single Sweep Drift/Degree C	0.04%F.S.
Sweep to Sweep Drift:	Negligible
Ground Reference Accuracy:	0.1%F.S.
Trigger Range, External:	+/-10V
Trigger Sensitivity, External:	0.5V
Trigger Range, Internal:	80%F.S.
Trigger Sensitivity, internal:	2%F.S.
Trigger Modes:	Auto/Normal
Max Pre-Trigger Delay Range:	99.9% sweep time
Max Post-Trigger Delay Range:	2 ²⁴ X time/pt

Other Features

- a)The ability to retain a reference signal on each channel.
- b)Sweep averaging at all speeds.
- b)Point averaging (inter-sample averaging) at speeds slower than 500us/pt.
- c)Trigger view mode for trigger set-up.

SECTION II
INSTALLATION

2.1 General

The equipment consists of two instrument racks. The first instrument rack houses five Bison inductance type soil strain gage instruments and the associated phase and amplitude controls and solid state switching hardware for switching these controls between sixteen separate measurement test sections. The Bison instruments can also be removed from this rack and used independently.

The second rack contains switching hardware for switching the actual input leads for the individual inductance coils associated with up to sixteen possible test sections. There can also be up to six other independent measurements at each of the sixteen test sections. These could be configured for any type of transducer including, pressure, soil strain gages, DCDT's, etc. Sixteen independent temperature sensors can also be monitored.

This rack also contains a data acquisition and analysis system which can be connected to any of the signals being monitored. It can be used for monitoring the input signals in real time, to store these signals in internal memory or on floppy disks, to analyze these signals and to do final graphics presentation of the results. This unit along with the control of the complete monitoring system can also be interfaced to a separate microcomputer as well as operated manually.

2.2 Power Requirements

All components require 110Vac power to operate. The Bison gages, however, have their own internal battery power which allows them to be operated for short periods of time without the use of 110 Vac power.

2.3 Signal Connections

The input signals from the bison strain coils are connected to individual input terminal blocks at the rear of the data Read-Out and Control Rack (See Figure 4 & 6). These coils are generally attached to RG58TU co-axial type cable and wired directly to these terminal blocks. The Bison instruments can also be removed and used as individual units. In this mode the inputs are wired directly to the back of each unit (See Figure 3 and Appendix C).

The individual transducer inputs are wired through the signal conditioning racks or directly to the main selector switch depending on the type of input(See Figure 2,4 & 6).

The Temperature sensors are wired directly to the temperature selection switch as described in the manufacturers literature (See Figure 2 & 4).

2.4 Induction Coils

The induction coils come in four basic sizes (1/2,1,2, & 4 inch diameter). Any size could be custom manufactured up to 14". They can be installed in two basic configurations, planner and

co-planner (See Figure 1,4,7,17 - 27). And in general will operate over a range of from one to three coil diameters. The response, over their full range is relatively non-linear with the highest output for a given displacement being near the closer spacings (See Figures 17 - 27). The output is, however, relatively linear over short distances, thus making them extremely useful for most short range dynamic measurement as well as being excellent for large scale static measuring devices.

The coils can be used in many ways, with one of their exceptional features being that they can be anywhere within the one to three coil diameter range and the exact spacing can be determined and any future deviation from this configuration can also be monitored. One coil can be placed directly above a second after it has been covered by simply moving the second coil above the buried coil until the maximum output is obtained. This insures that the second coil is directly above the first. There are many configurations and uses for these universal transducers (See Figure 34,35,36,A-1,A-2 & A-3).

2.5 Extensometers and Three Dimensional Array

The actual arrangement of the sensors used at the WSU test track consisted of five free-floating coils and an extensometer arranged in such a manner as to allow the measurement of two vertical strains, three vertical displacements, and the transverse and longitudinal strains at the pavement-subgrade interface. The configuration used is shown in Figure 1,4 & 7. It consisted of three coplanar coils: one at the pavement surface,

one between the pavement and subgrade, and one attached to the top an extensometer approximately two coil diameters below the bottom of the pavement. Two other coils were placed at the pavement-subgrade interface to allow the measurement of the longitudinal and transverse strains at this location (See Figure 1). In this arrangement only the central coil is excited thus inducing a voltage into the other four coils.

The displacement of the lower coil is obtained from the extensometer to which it is attached. The extensometer uses a pair of one inch coils as a sensing device and is constructed of two inch PVC pipe and stainless steel rods with an overall length of approximately 16 feet (See Appendix A). By knowing the absolute location of the coil on top of the extensometer and the initial coil separation readings and relative displacement of the two coils above it, the absolute displacement of each of these three coils can be obtained. This allows the measurement of seven variables from seven coils and five Bison instruments.

The extensometer are placed in the ground by drilling a 10 inch diameter hole approximately 16 feet into the ground. The bottom disk is grouted into place and the soil is slowly replaced and tamped securely into place around the unit. Much care must be used in aligning the units with the surface and in making sure that the proper spacing is maintained between the two coils within the units. About a one inch gap is ideal for initial installation in most road beds. However, if large amounts of settling are expected this initial spacing should be increased.

SECTION III

OPERATION

3.1 General

The different pieces of equipment can be operated as a unit or the Bison instruments and the data acquisition system can operated individually. The operation of these units individually are covered extensively in the individual manuals and will not be covered here (See Appendix B,C & D).

As a unit the Bison induction coil strain gages can be attached as shown in the three dimensional configuration as outlined in section II and Figure 1,4 & 7 or the units can be configured so as to wire the coils as separate pairs. Without modification to the relay board, the system is limited to only three coil pairs per test section unless a common excitation coil can be used in the final coil arrangement.

3.2a Front Panel Controls - Bison Instrument Rack

There are three remote control microswitches on the front panel of each bison instrument(see figure 3). These switches are used to switch the respective functions from internal, or normal front panel control to external, or switching rack control. These switches are not included in the manufacturers literature. For example, if the Amplitude remote control switch is in the up position, the Amplitude adjustment for each of the sixteen respective test section is controlled by the separate screw

control beside the respective Bison instrument instead of from the normal front panel control knob (See Figure 2, 8 & 10).

This is also true for the Phase control. The coil spacing control, however, is not active and is designed for use with an external control unit such as a remote computer system. The normal mode of operation while in the remote control mode for both the Amplitude and Phase controls would be to switch the main control switch (See Figure 2) to the desired test section and adjust the respective Phase and Amplitude potentiometers in the same manner as would be done under normal operation (see below and the Bison operations manual, Appendix C for these details).

The procedure is to adjust the Amplitude potentiometer until the needle on the face of the respective Bison gage (See Figures 2 & 3) is near the zero reading. Once this is achieved, hold the Amplitude-null-Phase momentary microswitch on the front of the Bison instrument down while adjusting the Phase potentiometer until the needle is near the zero position again. This procedure is repeated until the needle stays near the zero reading with the null switch in either the up(normal position) or down position. This is then repeated for each of the different Bison instruments and for each of the test sections that are being used. All coils for each of the sixteen test sections will have to have the same initial coil spacing or the coil spacing switch will have to be adjusted for each test section manually.

3.2b Readout and Control Rack

The front panel of the instrument control rack is used to

switch control from or to any one of sixteen possible test sections. Each test section can have up to five active Bison instruments and up to six separate measurements of any desired type. These measurements are wired through a separate signal conditioning rack and/or directly to the different input positions on the main multilayered rotary selection switch (See Figures 2,4 & 6). The outputs from each of these measurements are connected to the front panel through separate BNC connectors and can be connected directly to the Digital scope or to any other readout or recording instrument (See Figure 2). Included on the control rack is a digital voltmeter which can also be used to monitor the eleven separate measurements associated with each of the sixteen test sections.

There is also a separate temperature readout and switching unit on the monitoring panel. This is designed to use the Analog Device's AD 590 current sensing temperature probe. It can have up to sixteen separate sensors wired into it and operates completely separate from the rest of the unit.

3.3a Rear Panel - Bison Instrument Rack

The rear of the Bison instrument rack allows access to the back of the Bison instruments and to the solid state switching circuitry that is associated with the switching of the individual Amplitude and Phase adjustments. These adjustments are linked with the separate test sections and each respective inductance strain gage measurement. Also, access to the individual bison instruments and their respective battery charging units are

through this area. To remove the individual bison instruments from the racks all three side panels must be removed and the instruments must be removed from the top down. To remove the instruments, the rear brackets that hold them in place must be removed and the instruments lifted out from the top. To do this, the complete bracket assembly must be loosened to allow the units to be pulled out of their mounting positions.

3.3b Rear Panel - Readout and Control Rack

The rear of the instrument control rack gives access to the connectors for attaching the individual leads from the inductance coils and the inputs from all of the different input transducers. The mechanical switching gear is also in this rack, along with the power supplies and readout components. Included with the readout hardware is a digital scope which can be removed from this rack for separate use. See figures 2,4,5 & 6 for details.

3.4a Bison Instrument - Rear Panel

A complete description of the use of the Bison instrument is included in the manual that is provided with the instrument (See Appendix C). However, the major operation of the individual units are included here.

The two coils are connected to the rear of the instrument, either directly or through the switching circuitry, depending on the application. See Figures 2,3,4, & 7 for details on how to wire the three dimensional array of coils as well as the individual units. In the single measurement configuration, one

coil is connected to the OSC OUTPUTS (Oscillator output) connector while the second coil is connected to the SIGNAL INPUTS connector. The order in which the leads are connected is of no significance for a single pair type measurement. The two adjacent connectors associated with each signal are connected directly to each other internally and are provided as a convenience. The two switches on the rear of the Bison instruments should be the INT positions for normal single pair type measurement. The COIL SEPARATION switch should be set to the appropriate number corresponding to the approximate number of coil diameters between the coils. Playing with this adjustment and the front panel controls will help eliminate discrepancies in this setting.

The EXT OSC SELECT switch and the EXT OSC connectors allows for the connection of an external oscillator source signal which can be provided through an external instrument or from one of the other Bison instruments. When using more than one Bison instrument in a single set of measurements, it is recommended that a single unit be used to excite whatever coils that are needed and that the individual OSC OUTPUTs on each instrument be tied together. This will synchronize the instruments and improves their overall performance and accuracy (See Figures 4 & 7 for details on three dimensional array configuration).

The EXT REF SELECT allows for the use of an externally supplied reference for the individual instruments. This can be either a separate set of bison coils or a user supplied inductance device. Internally, the Bison instrument uses a factory supplied reference for the measurements that are made. Under unique situations an external reference can be required.

See manufacturers literature (Appendix C), and section VI.

3.4b Bison Instrument - Front Panel

The basic front panel controls are the on-off switch, the amplitude and phase adjustment section, the sensitivity-calibration setting, the coil spacing knob and the meter readout (+-100%).

The first step following the connection of the coils to the rear panel is to select the proper coil spacing. This is done by switching the knob back and forth until you see the read out needle move from one side to the other. At this point try turning the amplitude knob until you get the needle to move. The needle moves in the direction of travel of the top of the knob. If you fail to get the needle to move switch the coil spacing knob to the previous location where you found the original movement and try turning the amplitude knob until you detect movement in the needle. If at this point you fail to get results, check the coil connections and orientation. The coils will function in one orientation only, that is, you may need to reverse one of the coils or the leads. You should be able to get the needle on the readout to move from one side to the other by simply moving one coil relative to the other by hand. Once this has been accomplished, retry the above.

Once the needle can be balanced using the AMPLITUDE knob, press down and hold the AMPLITUDE-NULL-PHASE switch while adjusting the PHASE knob. Zero the needle with the PHASE adjustment. Now release the PHASE switch and rebalance the

AMPLITUDE adjustment. This process is repeated until both adjustments result in the needle staying at the zero position. This adjustment can get a little sensitive for high SENSITIVITY setting and for the smaller coils.

To set or reset the sensitivity to a previous setting, set the CAL SIGNAL dial to a known value and adjust the SENSITIVITY knob while holding down on the CALIBRATE switch to a known needle deflection. The normal procedure is to set the CAL. SIGNAL knob to 1000 and to adjust the sensitivity to a needle deflection of 100%. Recheck the AMPLITUDE and PHASE adjustments and repeat the above if necessary. You are now ready to take measurements or to calibrate the instrument. If a calibration has not been done for the coil size, configuration and sensitivity setting in use you will need to run a calibration, see section V. A second and convenient reference point is to turn the sensitivity knob to the full range setting, (full clockwise position), and ignore the sensitivity control completely.

3.5 Nicolet Instrument - Digital Oscilloscope

Full details for the operation of the Nicolet Instrument are extensive, and are covered in detail in the manufacturers manuals. To develop a full understanding of this instrument could take considerable time, however, to be able to collect, store and manipulate the basic data that is to be collected in normal operations is quite simple and will be described in detail in the following.

This instrument is basically a Digital oscilloscope and operates similar to a standard laboratory desk top analog scope.

To get things started set all the controls as indicated in Figures 11 & 12 and turn on the power by pushing in on the power switch (7-9). Turn the AUTO-NORM switch to AUTO(8-29), the TIME PER POINT switch (8-15) to 5 mS, the CHANNEL A switch (8-11) to on and press the STORAGE CONTROL - LIVE button. The unit should be on and scanning channel A. Turn the POSITION (8-21) knob back and forth and you should see the trace move up and down on the screen, or if you have a signal connected to one of the A inputs with switch (8-12 or 11) in the DC position you will see your signal. You may have to adjust the horizontal scale (8-14) and the position adjustment (8-21). To hold this signal on the screen after the finish of the current scan press the STORAGE CONTROL - HOLD LAST button. You can now play with any of the signal control controls on the mainframe unit. From this point you should follow the descriptions give in the Nicolet manuals that pertain to the specific function or control of interest.

There are four manuals that come with the instruments. These are the Digital Oscilloscope Manual, the Digital Oscilloscope Service Manual, the Waveform Analysis Manual and the Advanced Acquisition Manual. The first manual covers the basic operation of all of the front and rear panel controls and options associated with the operation of the Digital Oscilloscope. The second manual covers all the internal circuitry and calibration procedures required to maintain and service the equipment. The last two manuals are associated with the software that is provided for doing advanced waveform, acquisition and analysis. This software is extensive and these manuals should be consulted

for details on how to use this capability on the Nicolet Digital Oscilloscope.

Some of the other features that should be covered here are the floppy disk storage unit which can hold up to 80 records or traces, and the rear panel input/output options. The I/O options include the GPIB and RS-232C interfaces, external computer or terminal control and a RS-232C digital plotter driver port. This port will drive a serial HP 7470 plotter only. Also there are X-Y voltage outputs for driving an analog X-Y plotter, which can be controlled from the front panel in either real time operations or from the internal RAM memory or the floppy disk. Included in appendix B is a software package developed by the university for interface the unit to an IBM-PC. This package allows the operator to transfer data from the Nicolet floppy disk system to the IBM-PC.

3.6 Signal Conditioning

Provisions for signal conditioning electronics has been provided through two 44 pin PCB card chassis which are mounted near the bottom of the instrument control rack (See Figure 2). Connections are through wire rap pins on the back of the card chassis. The exact hook up will depend on what type of transducers and associated electronic signal conditioning are to be used. Because of the many options which exist, it was left up to the final application to define the hardware to be used. Included in Figure 32 is a suggested signal conditioning board which can be adapted to most any type of input.

SECTION IV

MAINTENANCE

4.1 General

The maintenance of the Bison and the Nicolet instrument are defined in the manufacturers literature. The overall maintenance of this and any comparable equipment should be done by a competent electronics technician.

4.2 Bison Instrument

The primary maintenance item on these instruments is the battery pack. From past experience they appear to last from two to three years. The instruments must be completely disassembled to get at the batteries. Remove the four screws on the back panel and remove the back panel. It is connected to the rest of the unit by electrical wires, so be careful. Turn this panel on its side and push the complete instrument out through the front. At this point remove the plate holding the battery pack in place and remove and resolder the leads from the new battery. The battery is manufactured by the Gould Corporation, Portable Battery division, St Paul, Minnesota 55114. The part number is 401097-6, and the unit is 12.0 volt, 1.2 AH. These units are considerably cheaper if purchased directly from Gould rather than the Bison Instrument Corporation.

Whether to leave the battery chargers plugged in while the

instruments are not in use is controversial and up to the individual. However, personal experience indicates that leaving the chargers on continuously or for regular time periods is preferable.

4.3 Switching Units

There is no special maintenance required other than keeping all components clean and dry. The mechanical switches can wear from normal use and should be replaced if normal cleaning does solve problems that may arise. See the individual schematics (See Figures 4 and 9) for part descriptions and numbers.

4.4 Digital Readouts

No special care is required other than to keep the units dry and free from dust. See the individual schematics and manufacturers literature for part numbers and factory repair policies (See Appendices F and G).

4.5 Nicolet Oscilloscope

The manufacturers literature (See Appendix D) should be followed carefully in maintaining this instrument. This is an extremely sensitive unit and should be maintained and calibrated by experienced factory trained personnel only. There is a local a factory representative (Mr. Hampson 206-771-2400) in Edmonds, WA. He is an extremely helpful individual and should be consulted immediately upon receiving this instrument.

SECTION V

CALIBRATION

5.1 General

There are several components that need calibration. These are the Bison instrument, the Nicolet oscilloscope, and the digital readout units. The Bison instrument requires a special calibration jig which is not available through the factory and will have to be constructed in house. See Figures 15 and 16 and the Bison manual.

5.2 Test Equipment Required

The Nicolet scope is all that is needed to calibrated the readout units and the Bison instruments, however, a good digital multimeter and frequency counter will help.

5.3 Procedure

Nicolet Oscilloscope

This unit should only be calibrated by a factory train technician. Call the local representative, Mr. Hampson (206)771-2400.

Bison Instrument

The Bison calibration process involves three distinct steps.

These are:

1. Development of coil spacing versus amplitude plots for the various coil diameters.
2. Development of coil spacing versus inches per volt relationships for the various coil diameters.
3. Development of strain multiplication factors (k') versus calibration signal.

Item 1 described above results in the initial relationships which enable measurement of the distance between any two strain coils. Thus, deflections between two strain coils can be measured over time or between a load or no load condition. These relationships can be directly used for static loading condition. Dynamic measurements require additional relationships which will subsequently be described.

The results of some typical calibration efforts are shown as Figures 17 through 30 and indicate the relationship between coil spacing and amplitude. The amplitude is used to achieve a signal balance or null condition, i.e., the difference between two amplitude readings correlates with change in coil spacing. Also shown in these figures are three coil separation ranges. These ranges correspond to a rough measure of coil separation distance (in terms of coil diameter) as follows:

- Range 1: 3/4 to 2.5 diameter for 1 inch coils
- Range 2: 1.5 to 3.5 diameter for 2 inch coils
- Range 3: 2.5 to 4.5 diameter for 4 inch coils

The same generalized curvilinear relationships for coil separation versus amplitude hold for 1 inch diameter (Figure 17),

2 inch diameter (Figures 18 and 19) and 4 inch diameter (Figures 20 and 21) strain coils. For the 2 inch and 4 inch diameter coils, calibrations for both parallel and coplanar configurations were necessary for the three dimensional configuration. Only one calibration was necessary for the 1 inch coil because these were used only in the parallel configuration; although, regression models were developed for the 1 inch coil in the coplanar configuration.

The procedure used to obtain the relationships shown in Figures 17 through 21 was to place two coils in a wooden jig (See Figure 15). One coil was slowly moved via use of a micrometer and corresponding amplitude readings were obtained. In this way a full series of coil spacing versus amplitude readings were obtained. The initial coil spacing was measured with a scale at three separate locations around the circumference of the coils. This distance was a center-to-center coil measurement. The sensitivity of the Bison instrument during this calibration process was at the maximum possible value (sensitivity knob in full clockwise position).

Although the previously described calibration process was adequate for measurements made in a static loading mode, additional calibrations were required to allow measurement of dynamic deflections. Dynamic deflection measurements required the use of voltages to determine changes in coil spacings. Thus, Amplitude readings were not sufficient and coil spacing versus inches of deflection per volt were made. This calibration process

was similar to that previously described except that a voltmeter was used to measure changes in coil spacings. These calibrations were made for all three coil sizes and both configurations (parallel and coplanar). This information is shown in Figures 22 through 27.

The calibrations shown in Figures 22 through 27 allow the use of a known coil spacing to determine a value of inches of deflection per volt. By measuring the voltage change between two coils during loading, the change in distance between coils can be computed. This relationship does not need to be modified if the Bison instrument is at the full sensitivity.

The final series of calibration were used to find relationships between change in deflection for constant voltage changes taken over a range of Bison instrument sensitivities. The sensitivity of the Bison instrument was quantified by use of the "Calibration Signal" which ranges from 1000 (maximum sensitivity) to no sensitivity). The ratio of the change in deflection at any calibration signal level and the change in deflection at a calibration signal level of 1000 was calculated and denoted as k' . This value is used as a multiplier to increase the deflection value determined from the calibrations shown in Figure 17 through 27. Thus, appropriate deflections can be determined for any Bison instrument sensitivity. The results of these calibrations are shown as Figures 27 through 29 for the three coil sizes. The k' values were determined for both the parallel and coplanar coil configurations but resulted in essentially the same relationship. Thus, the overall calibration procedure was

simplified slightly.

All calibration relationships were quantified by use of regression techniques. This enabled more accurate determinations (strains) to be made from the raw data. It is suggested that any extensive use of the existing equipment be preceded by a complete recalibration of all of the Bison instruments.

The regression equations (polynomials) are given in Figure 31. They include the coefficient of determination and root mean square error.

SECTION VI

THEORY OF OPERATION

6.1 General

The basic overall theory of operation was based on the need to integrate five Bison soil strain gages into a single system that will allow them to be used in a series of independent measurements by switching this group of five instruments between sixteen separate test sections. To do this it was necessary to deactivate the internal adjustments associated with the control of the individual Bison instruments, and supply external adjustments for each which could then be switched with the different inputs from the separate induction coils. Included in these controls are the adjustments for the individual amplitude and phase controls along with the coil separation switches.

To be included in the system was a mechanical means for switching between the separate test sections along with all necessary readout and display equipment to provide a stand alone measurement system.

6.2 Bison Gages

The system consists of a pair of coils and an instrument package that contains the bridge balance controls, as well as the power supply, and amplification and calibration functions. The output can be obtained in the form of either a null balance bridge reading, (a voltage). The general principle is that one of

the coils is excited with a high frequency voltage signal. A voltage is inducted into the second (or any other) coil by the first. The amplitude of this voltage is proportional to the spacing between the coils.

Calibration of the sensors is accomplished by separating the coils at various known spacings and determining the bridge balance reading of the instrument. The approach is conceptually the same for parallel, coplanar or orthogonal sensor configurations. Because the calibration relationship is nonlinear, more than two points are needed to establish the curve for spacing changes of more than 5%. The most general calibration method employs a fixture with a micrometer to accurately produce and measure small changes in spacing of one coil with respect to the other (See Figure 15). A more rapid method can be provided for a particular size sensor by using a fixture with slots of known spacing (See Figure 16).

Coil diameters ranging from 1/2 to 14 inches have been tested and found to give about the same strain sensitivity. Normal operating spacing for each size is 1 to 4 times the diameter. Maximum resolution over a period of months is 0.04 percent strain, but dynamic resolution smaller than 0.001 percent strain can be obtained the voltage or recorder output. The limitations of this resolution are internal noise and external factors influencing the electromagnetic field, such as moving metal object close to the sensor.

The inductance coil is insensitive to such factors as soil composition, moisture content, temperature, and cable length. The

major adverse factor is the presence of metal, particularly ferrous, in the zone of influence of the electromagnetic field which couples the pair of sensor coils. The extent of the effect in any particular case can easily be determined. The effect of fixed metal objects on the bridge balance readings will often cancel out in determining strain. The effect of large metal objects which produce significant shifts in readings can be handled by corrected calibration curves. In the past, the main problem with metal has been in dynamic strain determination where moving metal accompanied the moving load that produced the strain. An example is the determination of strains beneath a pavement under traffic loads. This effect is reduced substantially by the height of the vehicle in question and is negligible for larger trucks. This same phenomena is experienced with induction loop type detection systems.

6.3 Secondary Amplitude and Phase Adjustment

The Bison instruments have been modified to allow for external balancing control for the amplitude and phase adjustments when the microswitches beside each function is put in the up position. This gives a separate balancing control for each of the sixteen separate master selection switch positions. The screw driver adjustments beside each individual Bison instrument becomes the phase and amplitude adjustments (See Figures 2 and 3). With the microswitches in the down position the Bison instruments function as defined in this manual and manufacturers literature.

6.4 Switching Network

The switching network associated with the control of the instrument package has two basic components. The first is the switching circuitry associated with the individual amplitude, phase, and coil spacing controls on the separate Bison instruments. At present the coil spacing control is deactivated and is accessible for expansion purposes only (See figures 9 and 10 for details). The second portion is the switching circuitry associated with the switching of the input leads from the different induction coils and independent transducer inputs and the control of the monitoring signals or outputs from each of the sensors being used in the overall monitoring system.

The function of the channel selection switch on the Read Out and Control Rack (See Figure 2) is to switch the sensor input leads from the test section in question into the system and to connect the outputs from each of the signals to the appropriate BNC connection on the front panel. This switch also switches the balance control for the individual amplitude and phase adjustments associated with each Bison instrument to the appropriate external adjustment potentiometer if the microswitch for that function on the face of the individual Bison instrument is in the up position.

The individual outputs are manually connected to the oscilloscope, to the digital panel meter and/or to any type of user supplied monitoring unit. This was done to leave the system as flexible as possible. Individual applications may dictate that

some of these controls be connected directly to various readout equipment.

6.5 Optional Signal Conditioning

Space and card chassis have been provided for signal conditioning circuitry for the externally switched signals associated with each of the test sections. There is space for six of these signals for each of the sixteen switch settings; this in conjunction with the Bison instruments. The type of transducer which is wired through this system is only limited by the circuitry which is used. The card chassis excepts a 44 pin 4.5 inch by 7.5 inch circuit board. There is a circuit diagram and printed circuit board layout given in Figures 32 and 33. This circuit can be adapted to except any voltage (differential or single ended) or resistive type input. Other circuitry can be purchased or designed to function in this piece of hardware. This type of circuitry will have to be defined by the final application and the transducers that are to be used.

6.6 Transducer Inputs

The inductance coils are generally co-axial cables and are wired into the rear of the Read Out and Control Rack (See Figures 4 and 6), all grounds associated with each section are tied together at their respective connectors. They are connected directly to the screw type terminal strips as indicated in Figure 4. These leads are switched, through mercury wetted relays to the individual Bison instruments. The secondary inputs, (there are

six associate with each of the sixteen test sections), are either wired directly to the channel selection switch or through the signal conditioning chassis, depending on the type and output characteristics of the individual transducer or measurement that is to be made.

6.7 Three Dimensional Transducer Array

The three dimensional inductance transducer array that is shown in Figures 1, 4, and 7 is a unique arrangement and was used in the original implementation of this equipment at the WSU test track. This system uses four coils and an extensometer arranged in such a manner as to allow for two vertical strains, two horizontal strains, and three vertical displacements. This is done using only the five Bison instruments. The center coil "A" is excited and the inducted voltages in coils B, C, D and E are monitored using the first four Bison instruments. The fifth Bison instrument is used to monitor the coils used in the extensometer (See Figures 1, 4, 7, A-1, A-2 and A-3).

6.8 Nicolet Oscilloscope

This instrument is an extremely versatile data acquisition system. It can be operated independently to perform most any desired data collection, real time analysis, data storage and post analysis, and data display function. The unit can be interfaced to a separate mini or microcomputer for post type data analysis or it can operate as a front end to a computer system for real time data acquisition and analysis.

The scope is limited to only two channels and can be expanded to a maximum of four channels. This is only a limitation if real time cross spectral or correlation type analysis is needed for more than the two channels. This should not be a problem in the expected applications for this equipment. Alternate pairs can be analyzed if desired.

SECTION VII

SCHEMATICS, DRAWINGS AND FIGURES

7.1 General

This section contains all of the drawings and figures associated with this manual.

7.2 List of Figures

- Figure 1 - Field Installation - WSU Test Track
- Figure 2 - Instrument Racks - Front and Rear Panels
- Figure 3 - Bison Gages - Front and Rear Panel
- Figure 4 - Interconnect Diagram for Instrument Racks
- Figure 5 - Bison Instrument Rack - Mounting Detail
- Figure 6 - Relay and Coil Input Board Details
- Figure 7 - Bison Gage Inner connect for Three Dimensional Coil Arrangement
- Figure 8 - Circuit Board Components Layout and Parts List
- Figure 9 - Switching Circuit and Control Diagram
- Figure 10 - Remote Control Circuit Diagram
- Figure 11 - Nicolet Plug-in Amplifier Unit
- Figure 12 - Nicolet Mainframe
- Figure 13 - Nicolet Disk Recorder
- Figure 14 - Nicolet Input/Output Panel
- Figure 15 - Bison Calibration Jig - Adjustable
- Figure 16 - Bison Calibration Jig - Stationary
- Figure 17 - Bison Calib - Spacing vs Ampl - 1" Coils Parallel
- Figure 18 - Bison Calib - Spacing vs Ampl - 2" Coils Parallel
- Figure 19 - Bison Calib - Spacing vs Ampl - 2" Coils Coplanar
- Figure 20 - Bison Calib - Spacing vs Ampl - 4" Coils Parallel
- Figure 21 - Bison Calib - Spacing vs Ampl - 4" Coils Coplanar
- Figure 22 - Bison Calib - Spacing vs Volts - 1" Coils Parallel
- Figure 23 - Bison Calib - Spacing vs Volts - 1" Coils Coplanar
- Figure 24 - Bison Calib - Spacing vs Volts - 2" Coils Parallel
- Figure 25 - Bison Calib - Spacing vs Volts - 2" Coils Coplanar
- Figure 26 - Bison Calib - spacing vs Volts - 4" Coils Parallel
- Figure 27 - Bison Calib - Spacing vs Volts - 4" Coils Coplanar
- Figure 28 - Bison Calib - k' vs Calib Signal 1" Coils
- Figure 29 - Bison Calib - k' vs Calib signal 2" Coils
- Figure 30 - Bison Calib - k' vs Calib Signal 4" Coils
- Figure 31 - Bison Calib - Regression Equations
- Figure 32 - Suggested Signal Conditioning Electronics
- Figure 33 - Suggested Signal Conditioning PCB
- Figure 34 - Alternative Application for Induction Coils
- Figure 35 - Alternative Application for Induction Coils
- Figure 36 - Photograph of Inductance Coils
- Figure 1A - Extensometer - General Detail
- Figure 2A - Extensometer - Bison Coil Sensor Detail
- Figure 3A - Extensometer - End Plate and Guide Detail

90 FOOT DIAMETER ROTARY
PAVEMENT TEST APPARATUS

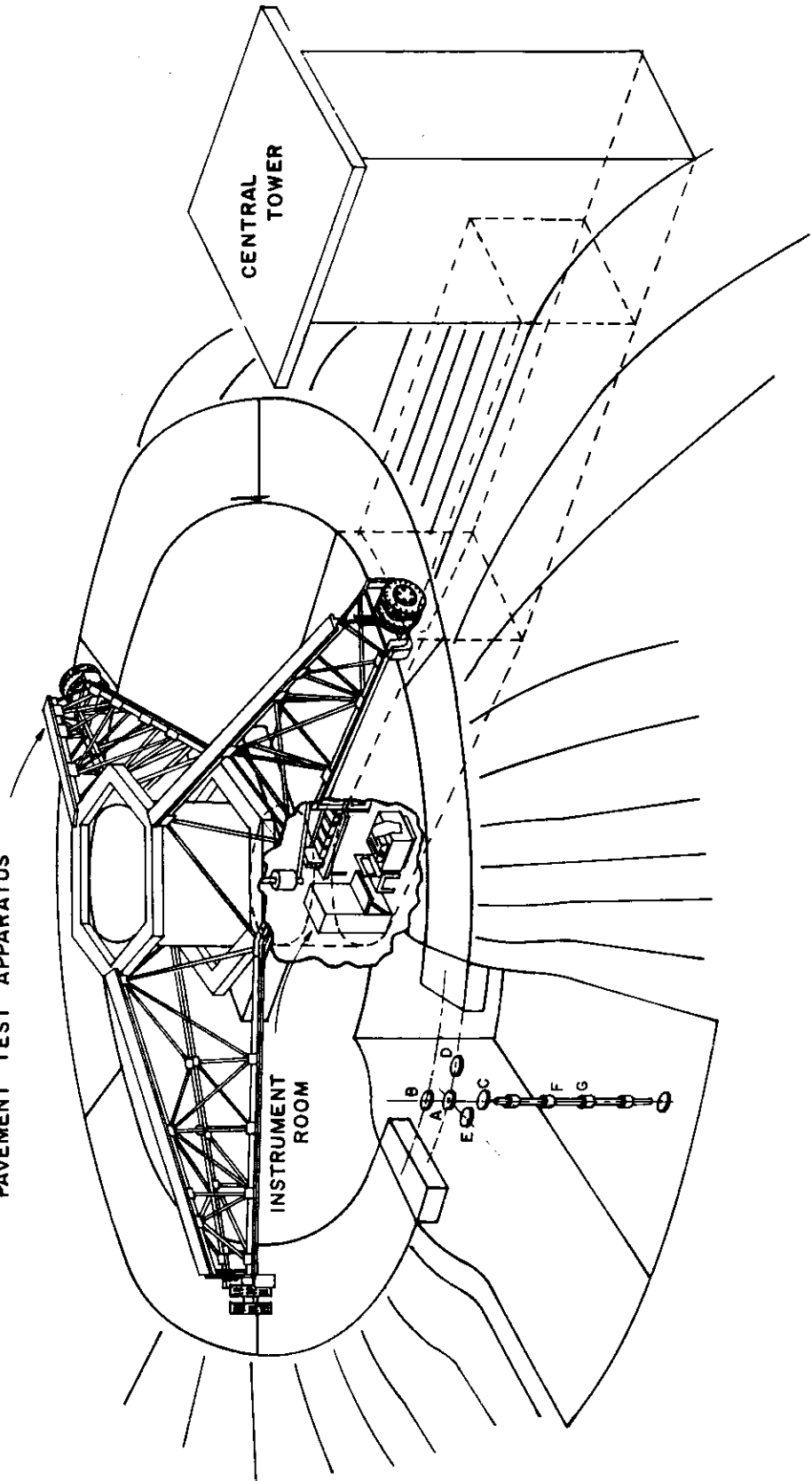

CENTRAL
TOWER

INSTRUMENT
ROOM

A B C D E F G

Figure 1 Field Installation - MSU Test Track

INSTRUMENT RACKS

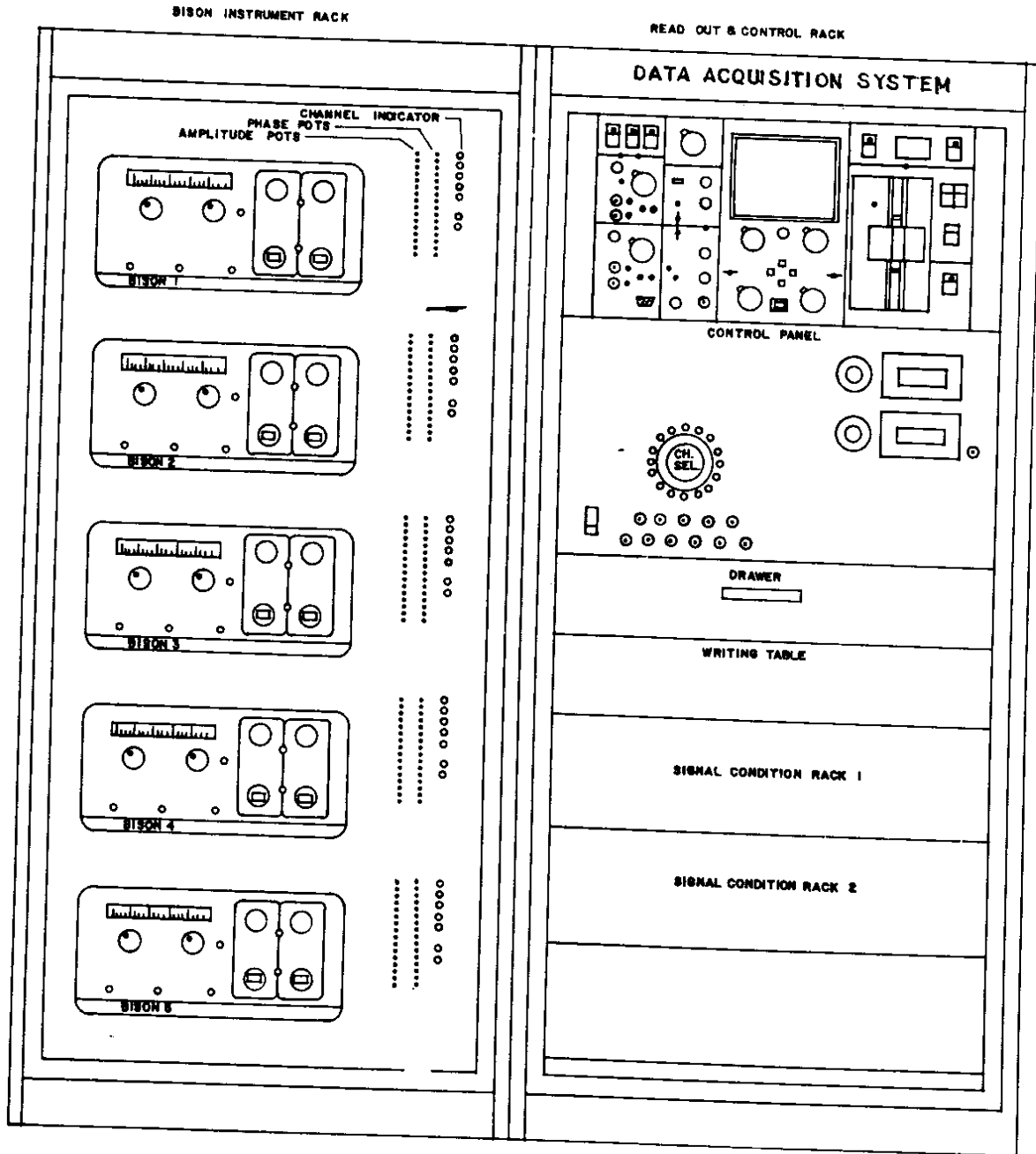
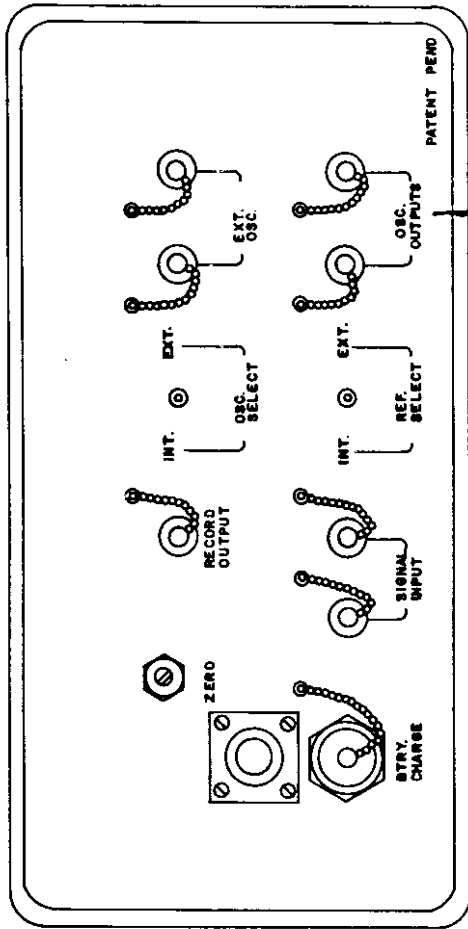
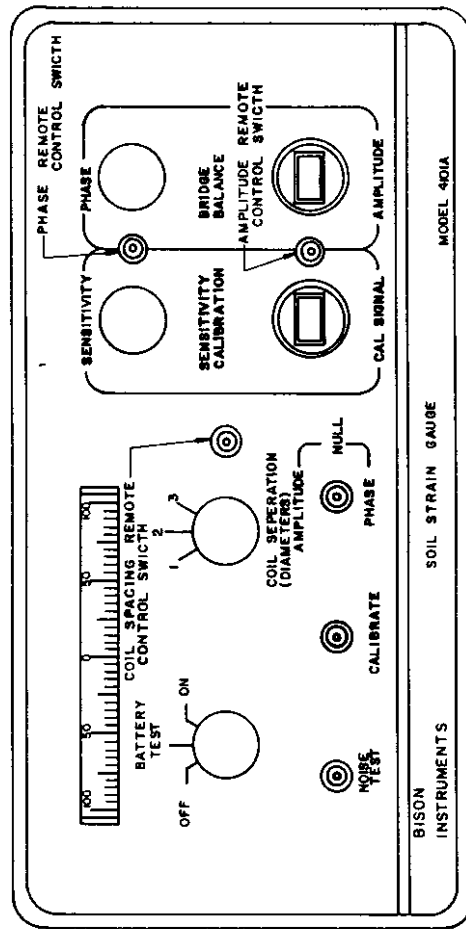

Figure 2 Instrument Racks - Front Panels



REAR BISON GAUGE PANEL



FRONT BISON GAUGE PANEL

Figure 3 Bison Gages - Front and Rear Panels

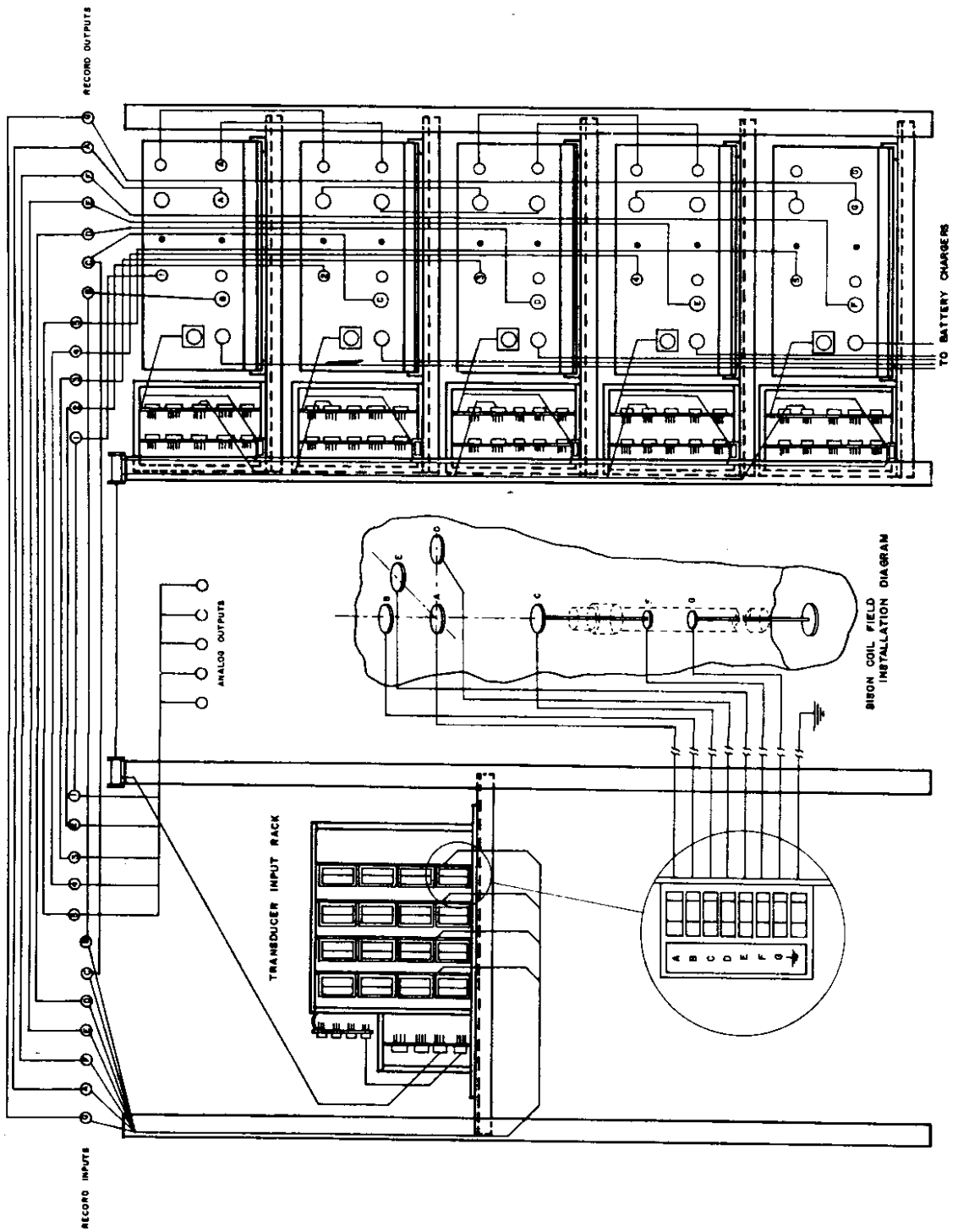

Figure 4 Interconnect Diagram for Instrument Racks

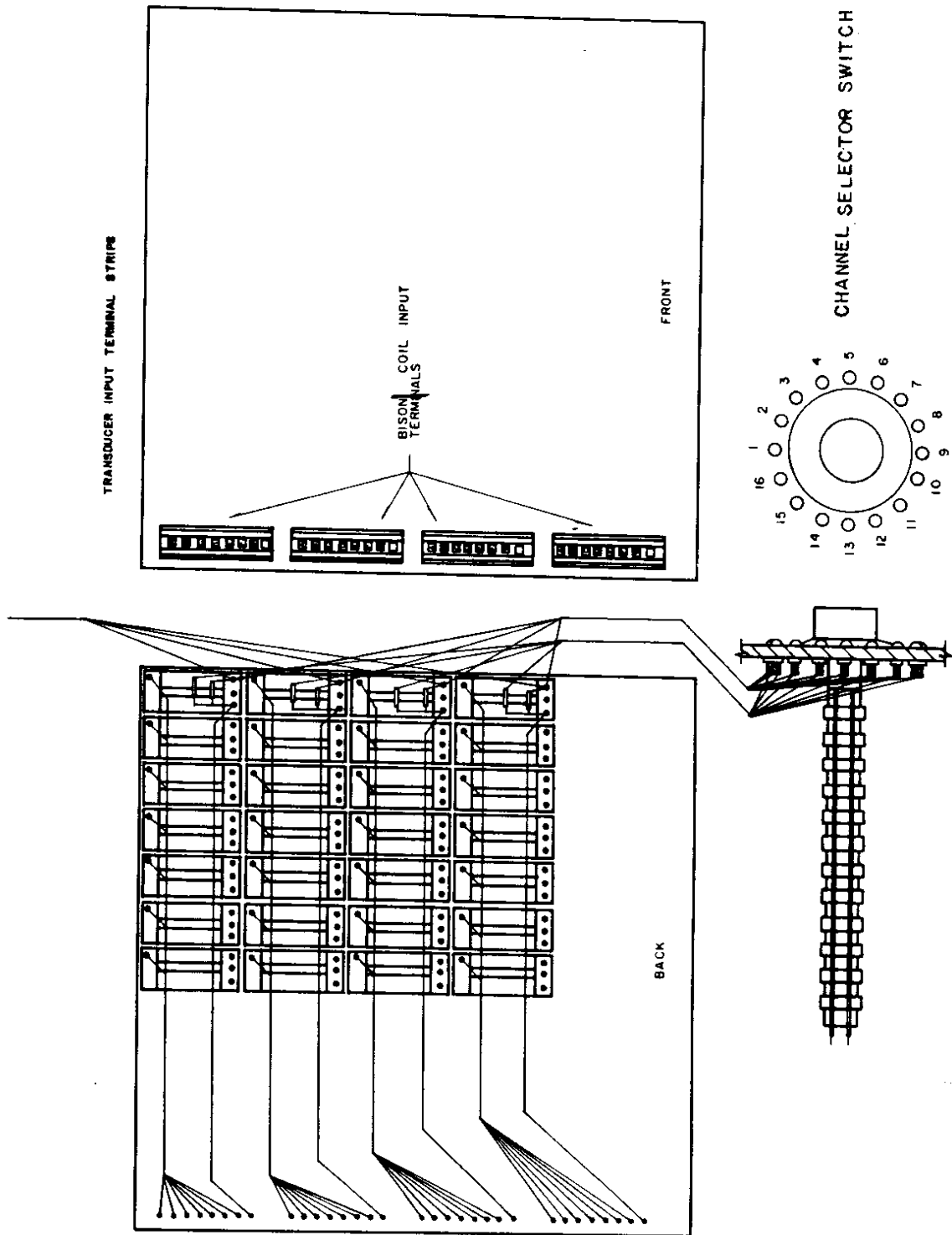

Figure 6 Relay and Coil Input Board Detail

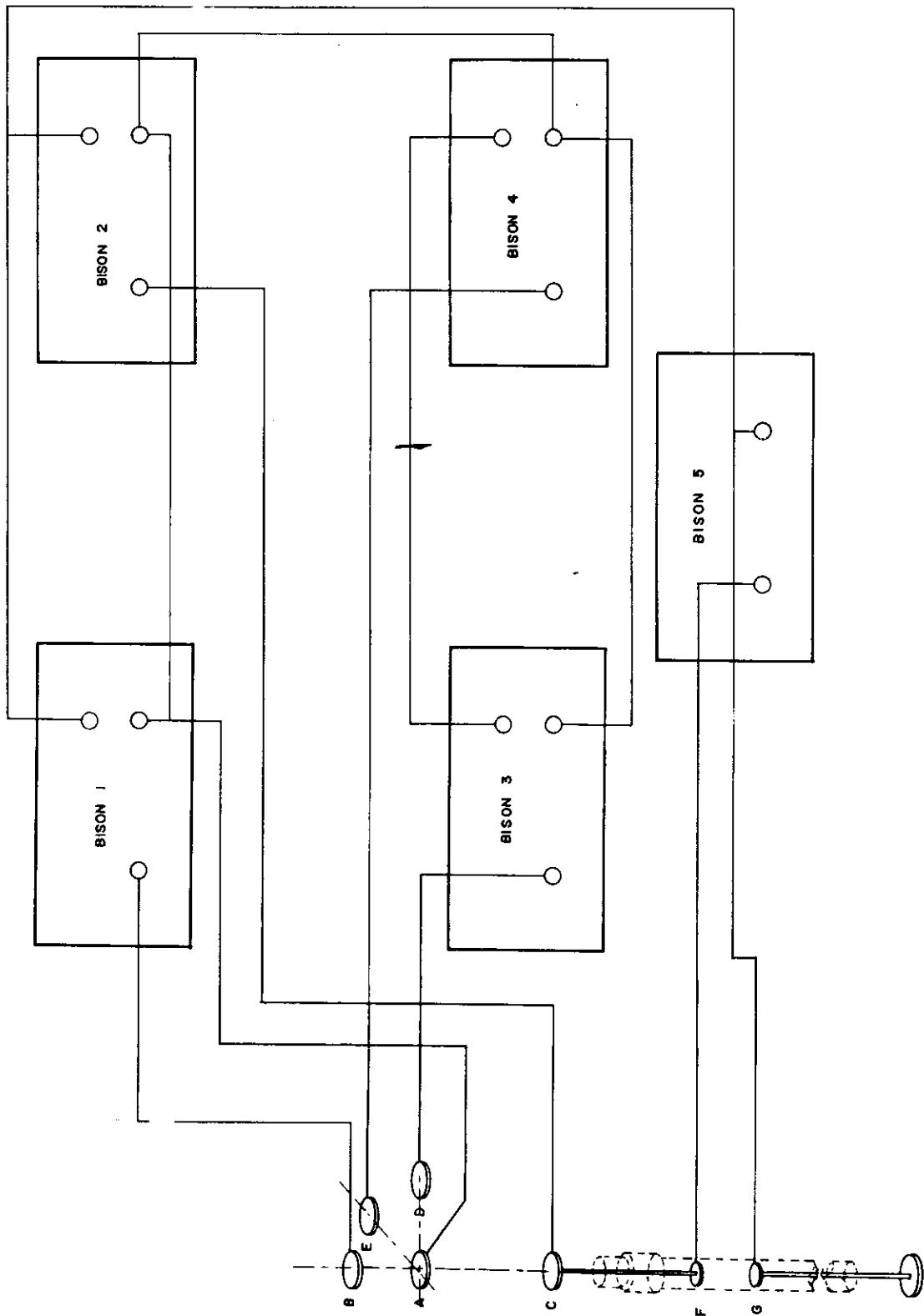

Figure 7 Bison Gage Inner Connect For Three Dim. Coil Arrangement

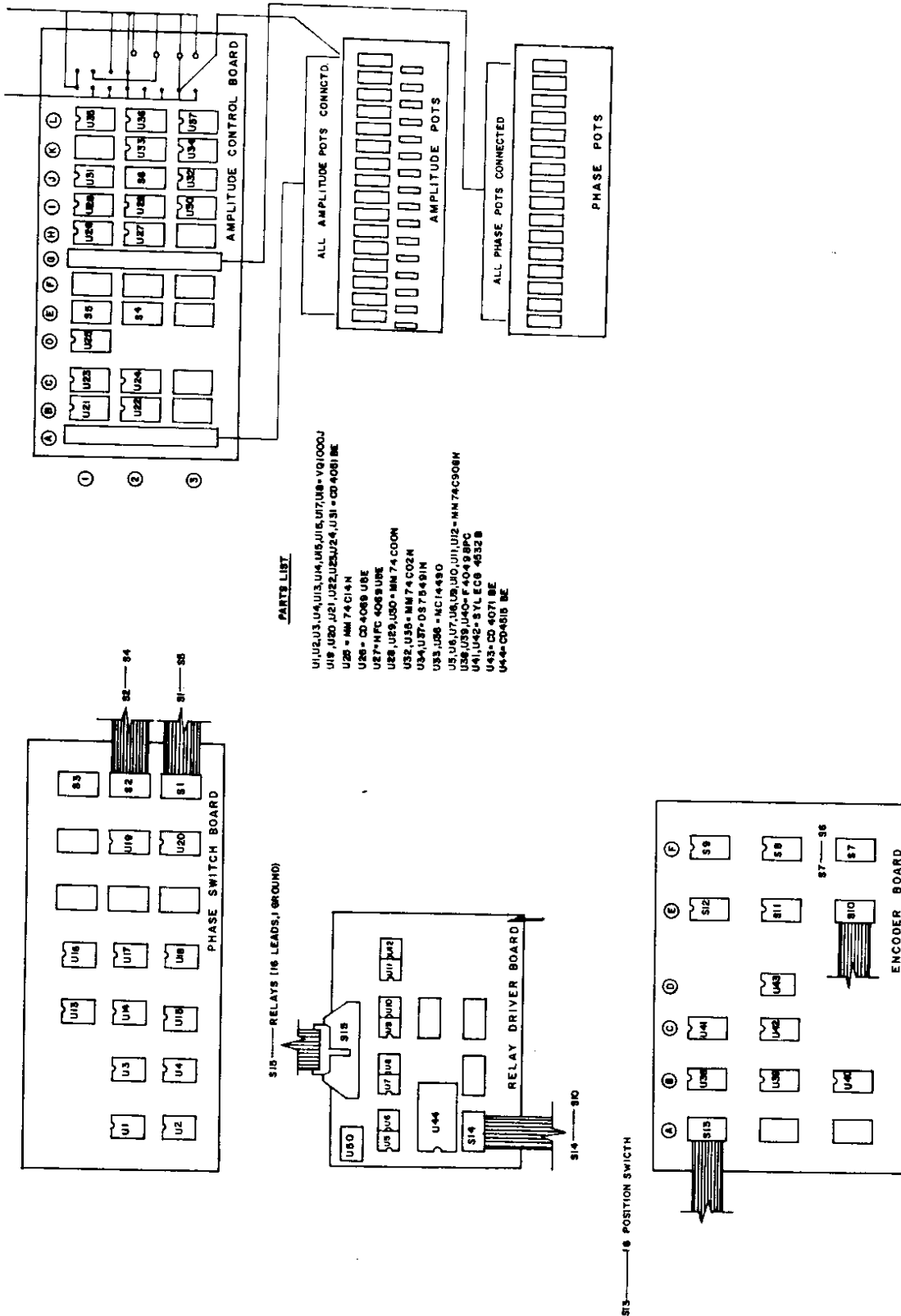

Figure 8 Circuit Board Component Layout and Parts List

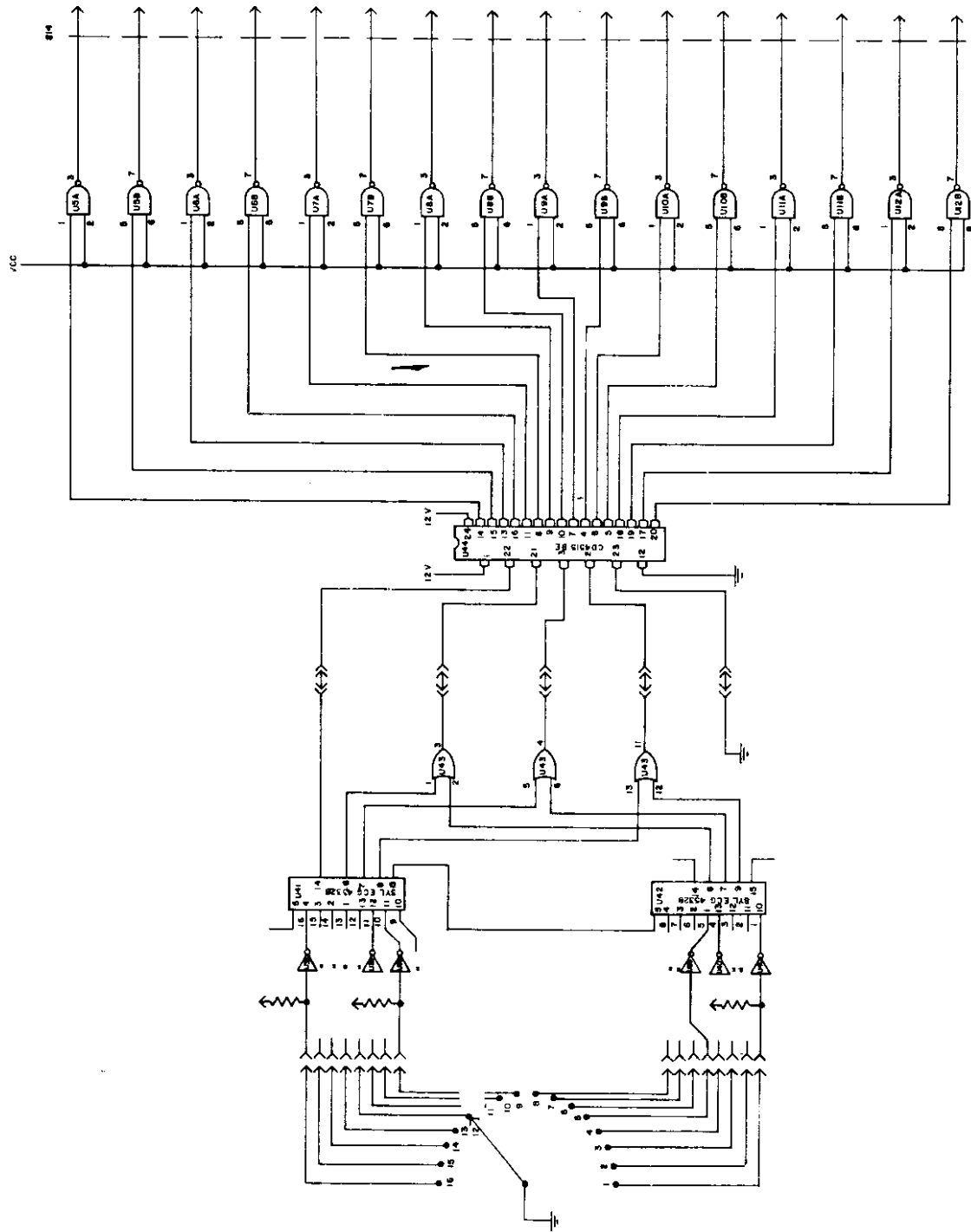

Figure 9 Switching Circuit and Control Diagram

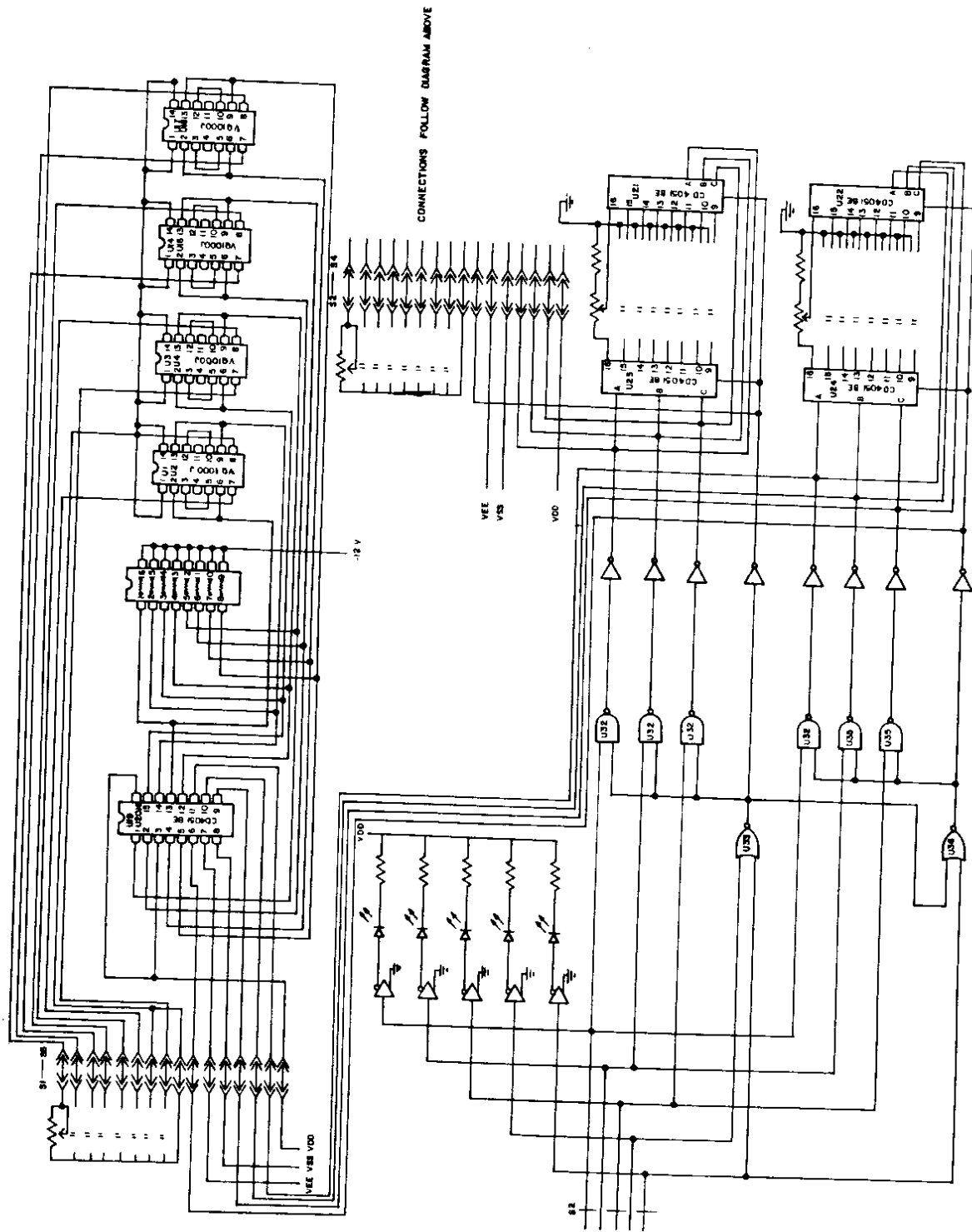

Figure 10 Remote Control Circuit Diagram

Model 4562 Plug-in

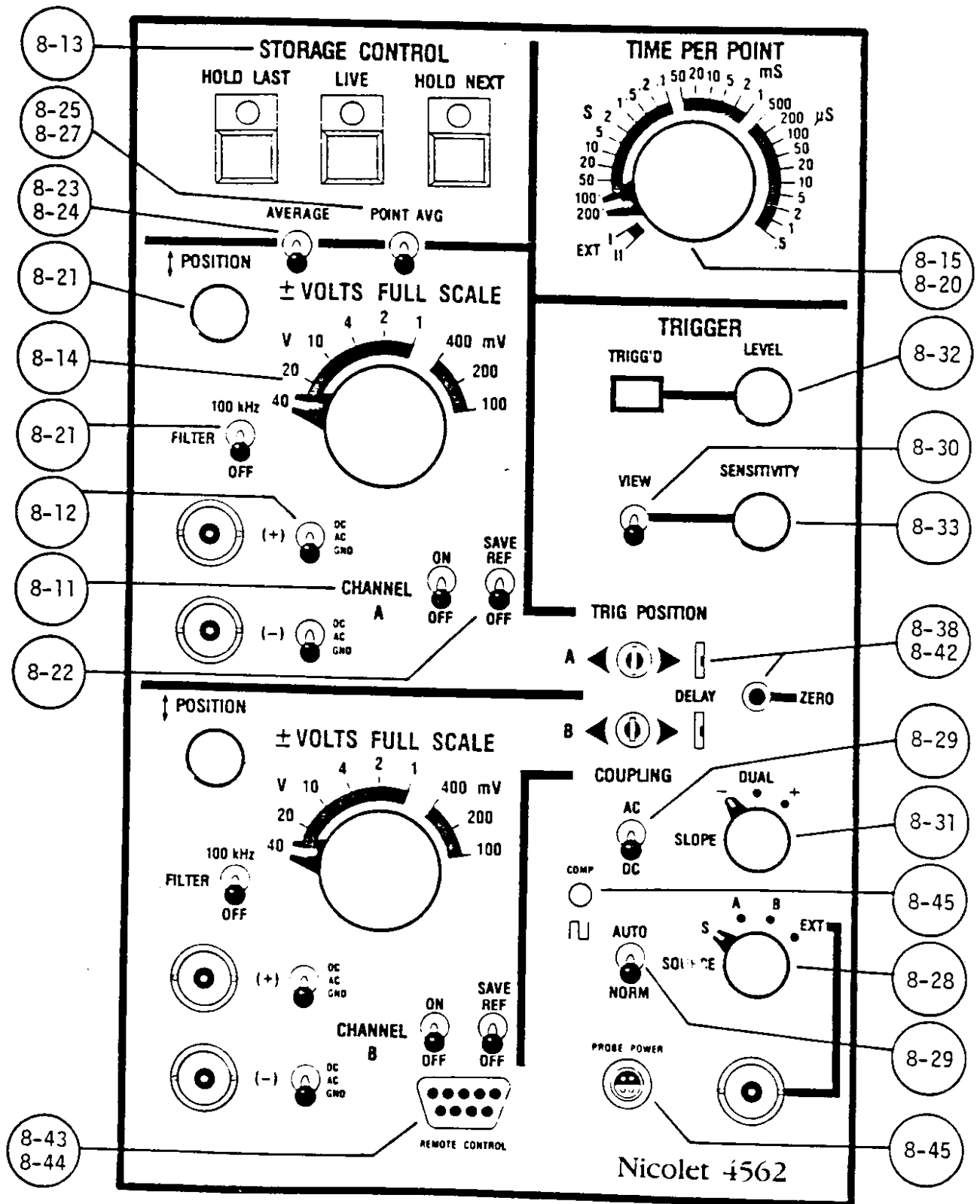

Figure 11 Nicolet Plug-in Amplifier Unit

Mainframe

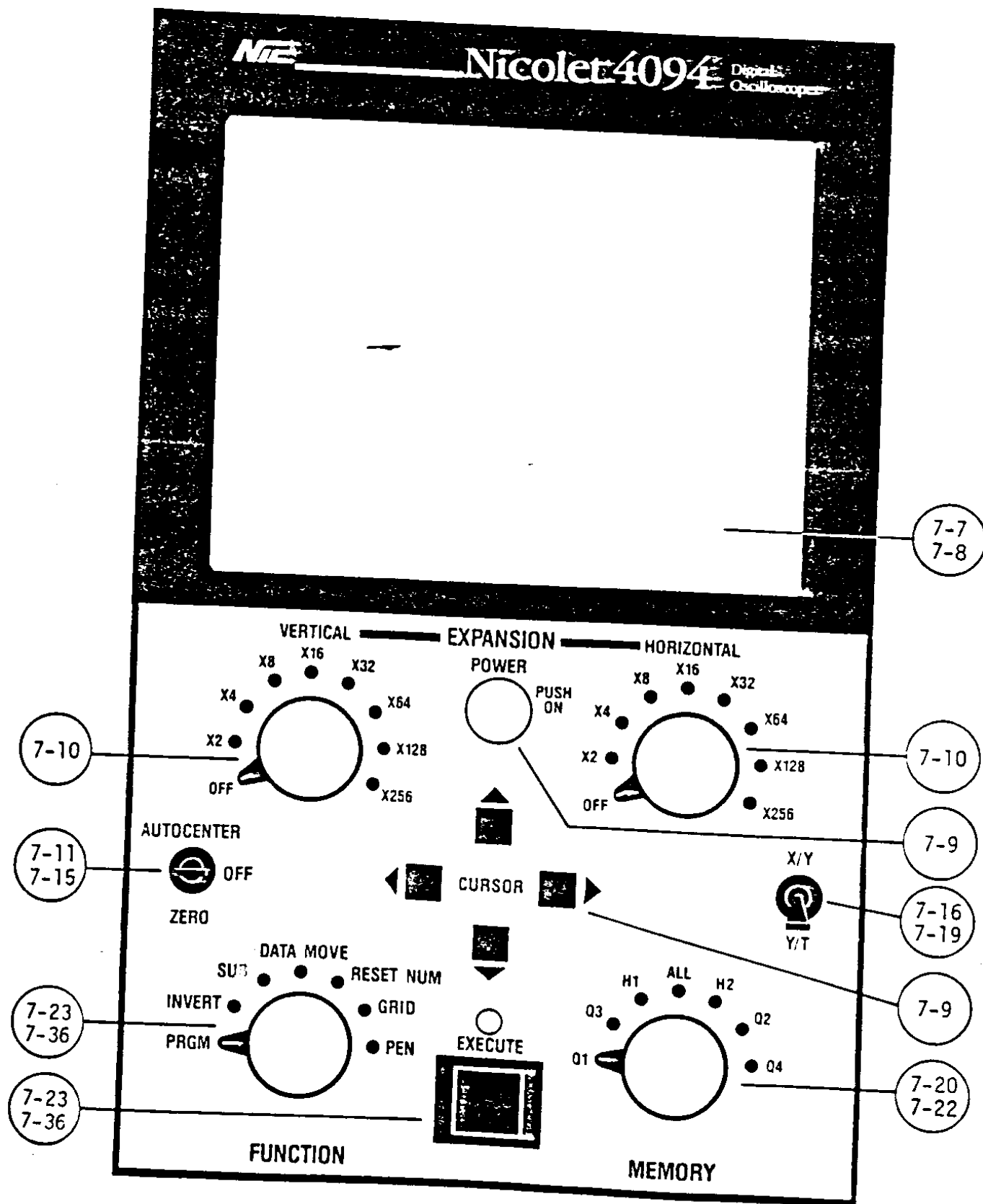

Figure 12 Nicolet Mainframe

Disk Recorder—F-43

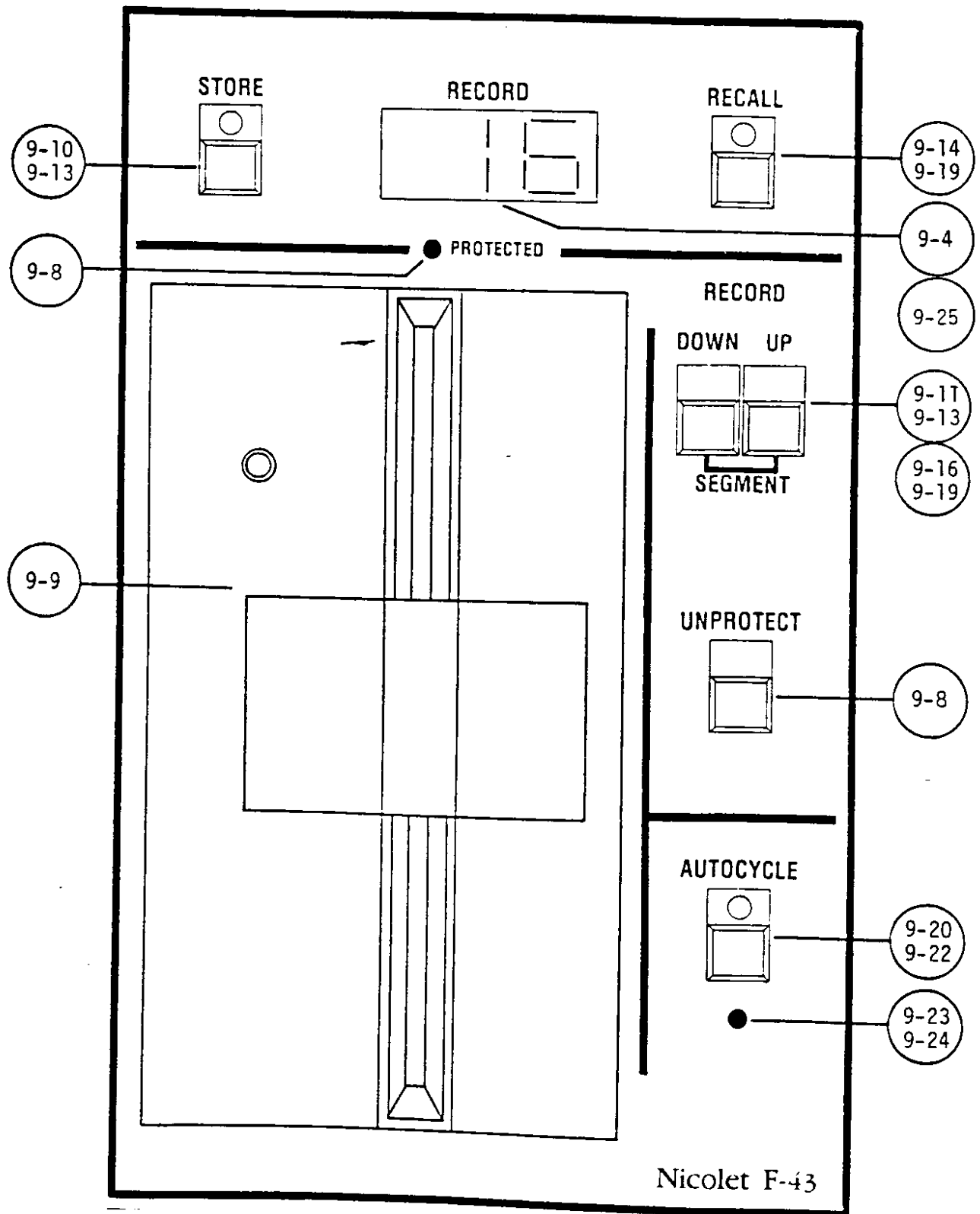

Figure 13 Nicolet Disk Recorder

Input/Output Panel

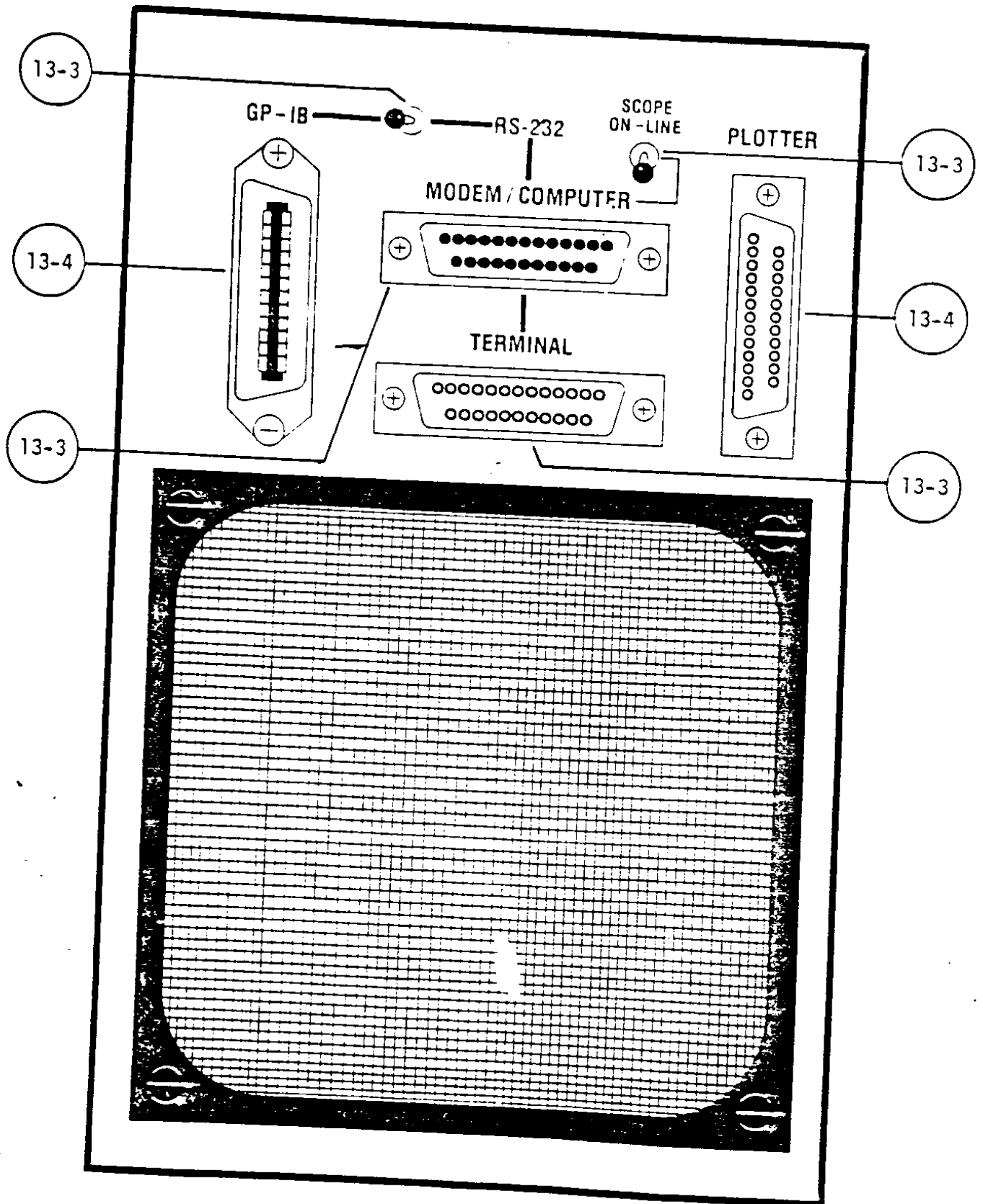

Figure 14 Nicolet Input/Output

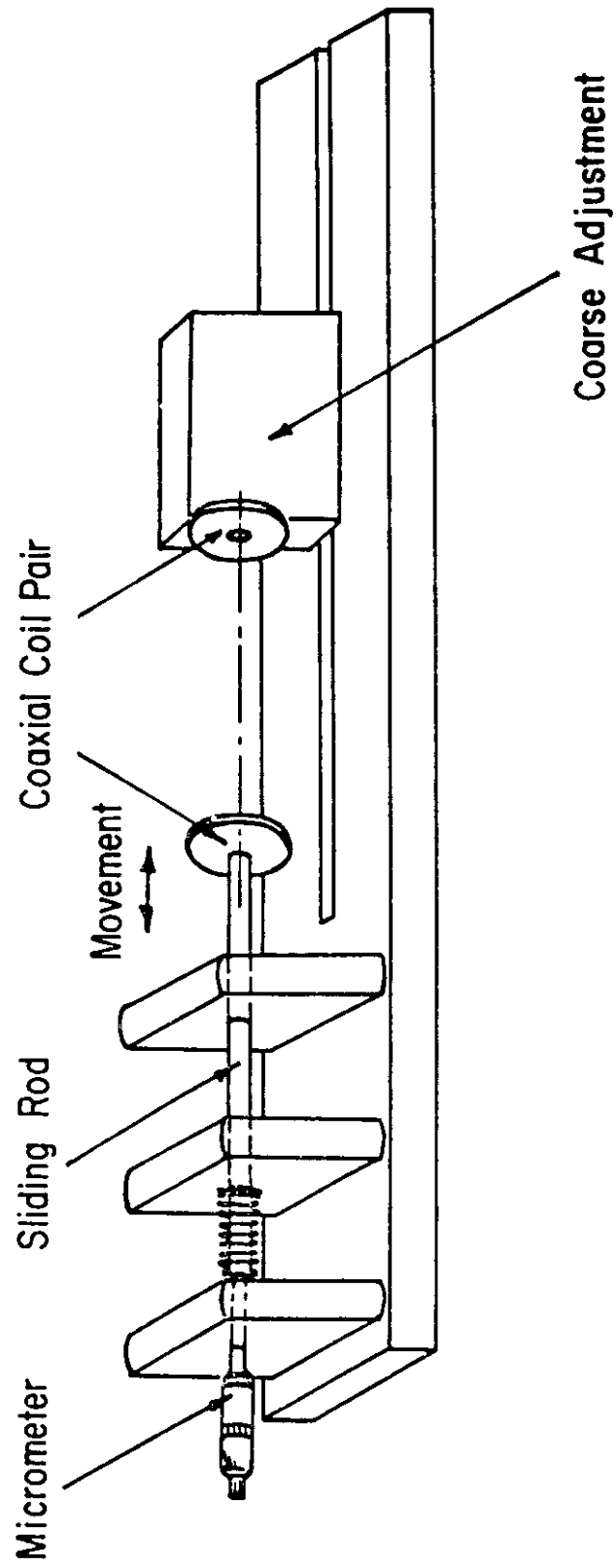

Figure 15 Calibration Fixture for Sensors

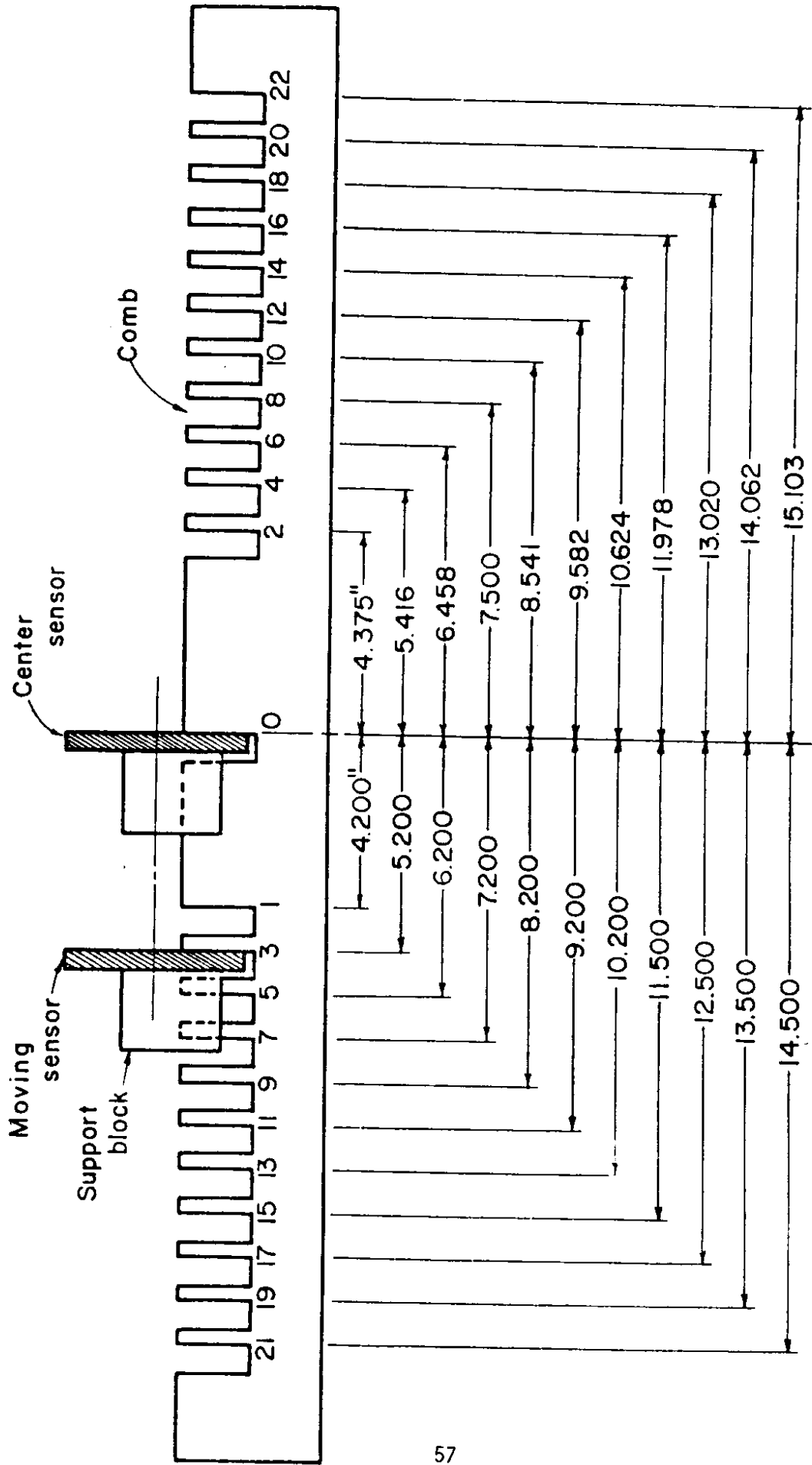
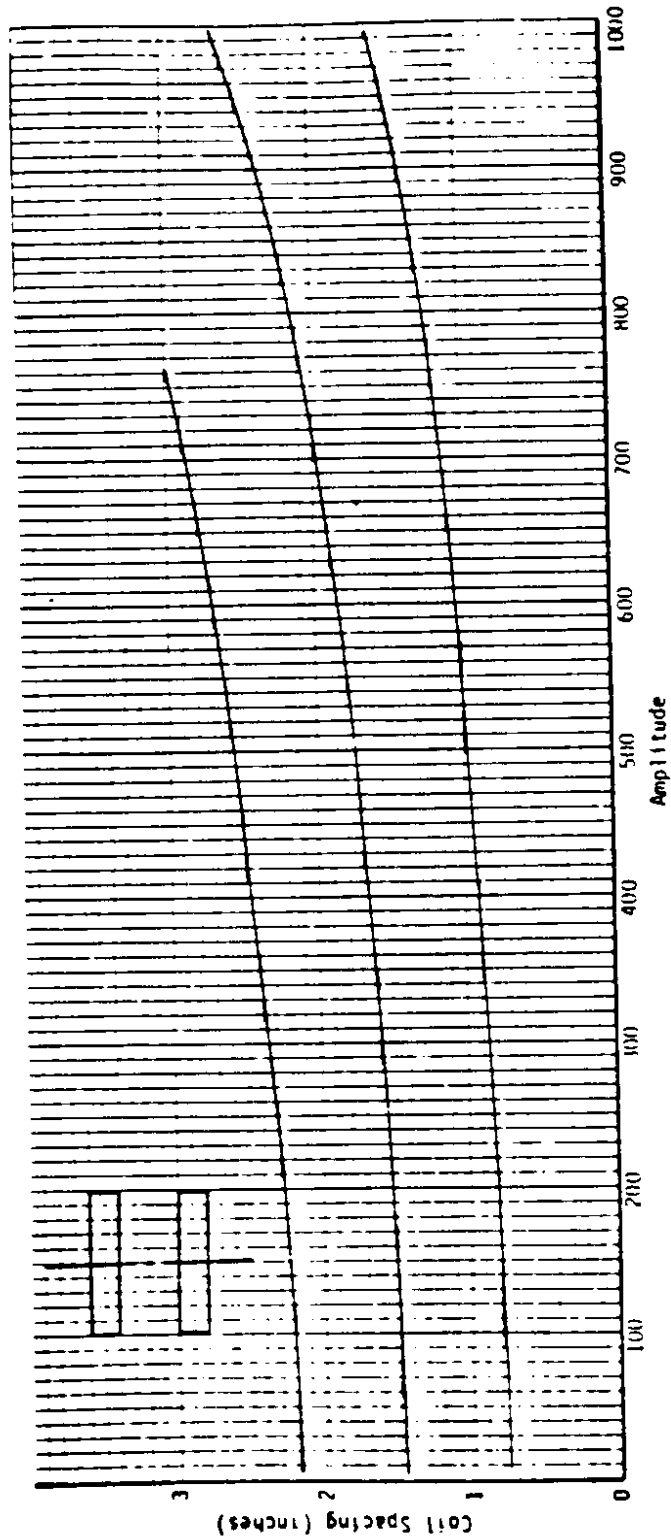

Figure 16 Calibration Comb Dimensions
for 4-in. Sensor



1 cm = 0.394 in

Figure 17 Coil Spacing vs. Amplitude for One Inch Diameter
Bison Strain Coils (Parallel Configuration and
Maximum Sensitivity)

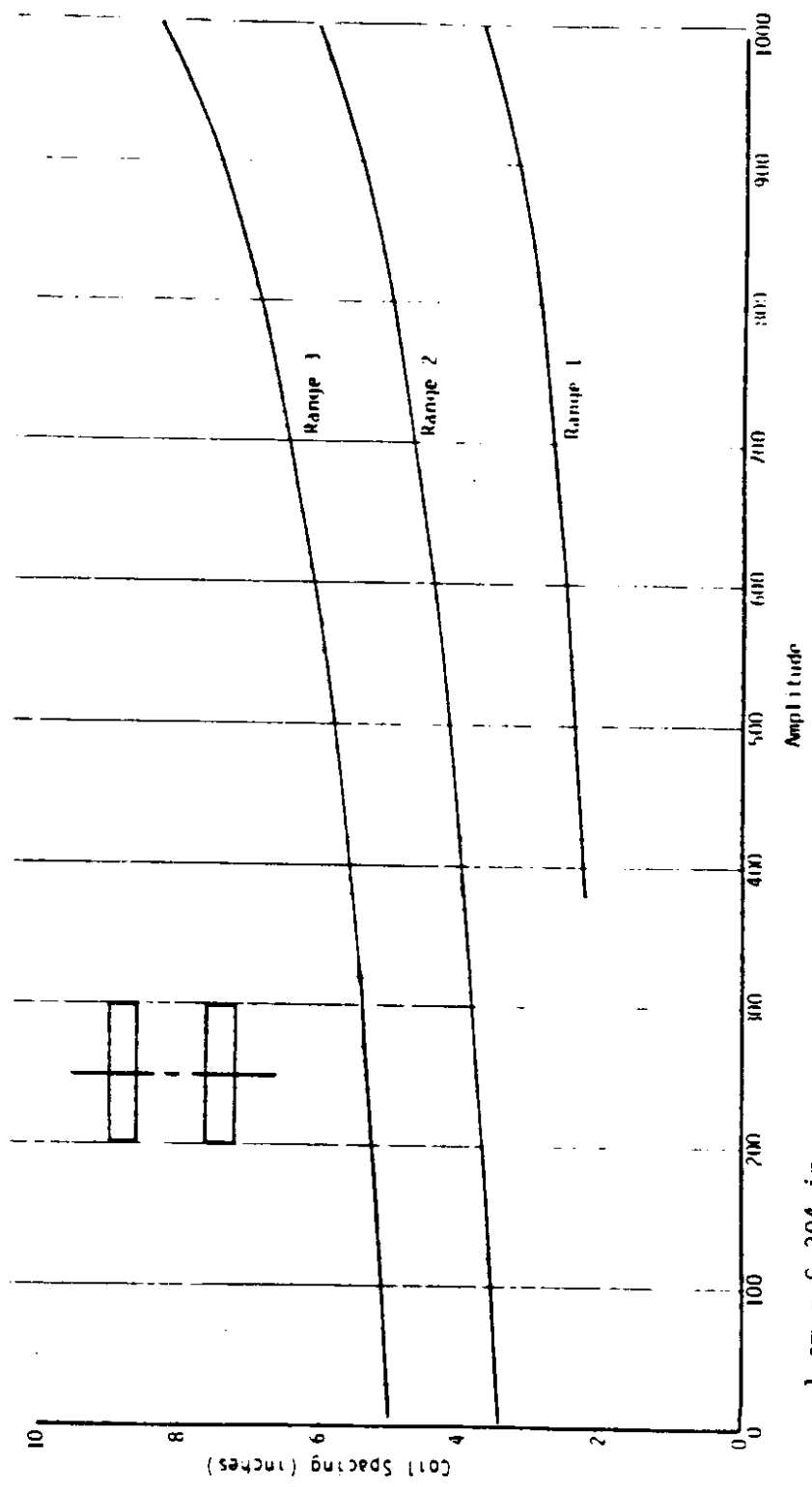
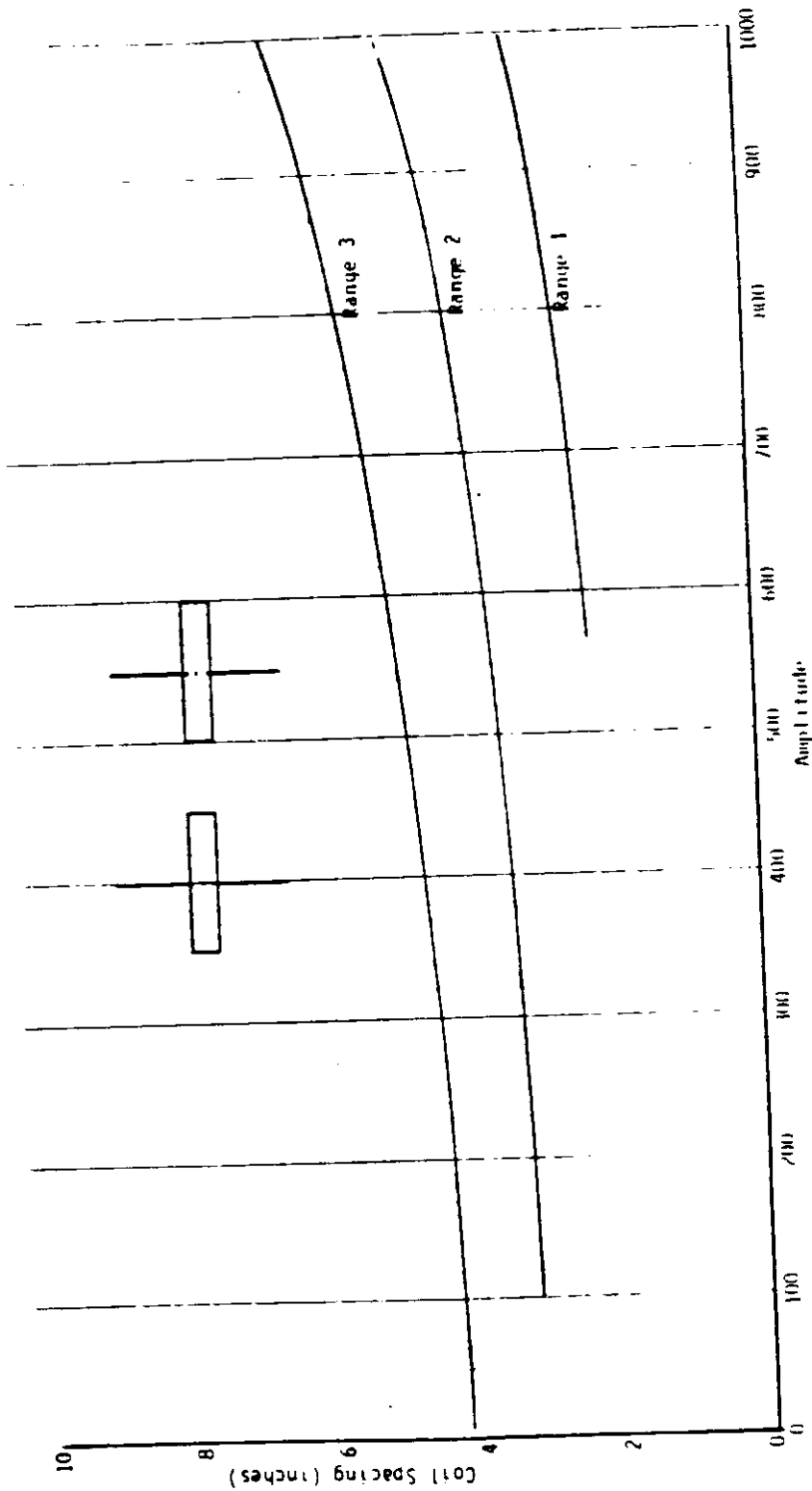
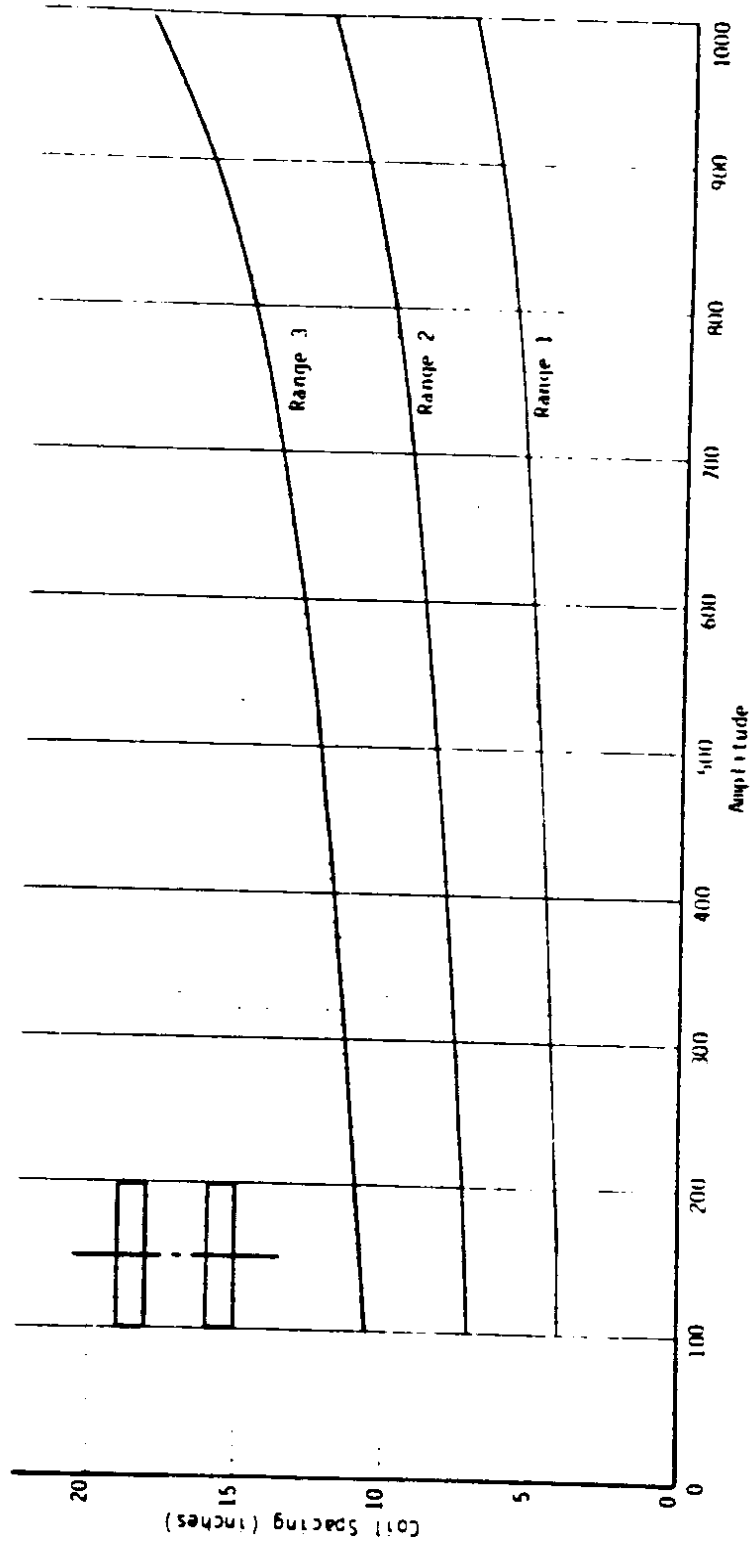

Figure 18 Coil Spacing vs. Amplitude for Two Inch Diameter Bison Strain Coils (Parallel Configuration and Maximum Sensitivity)



1 cm 0.394 in

Figure 19 Coil Spacing vs. Amplitude for Two Inch Diameter Bison Strain Coils (Coplanar Configuration and Maximum Sensitivity)



1 cm = 0.394 in

Figure 20 Coil Spacing vs. Amplitude for Four Inch Diameter Bison Strain Coils (Parallel Configuration and Maximum Sensitivity)

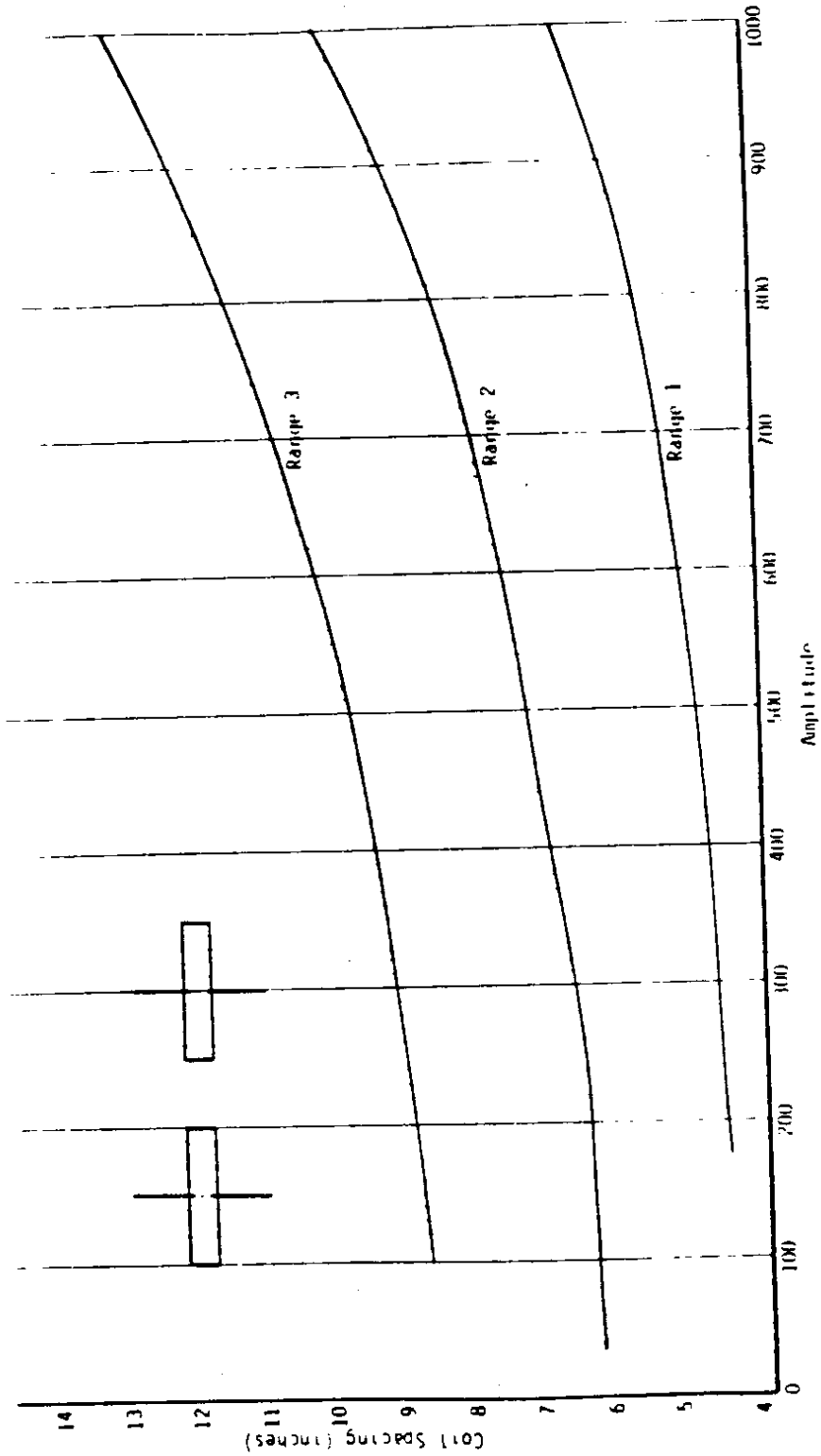

1 cm = 0.394 in

Figure 21 Coil Spacing vs. Amplitude for four Inch Diameter Bison Strain Coils (Coplanar Configuration and Maximum Sensitivity)

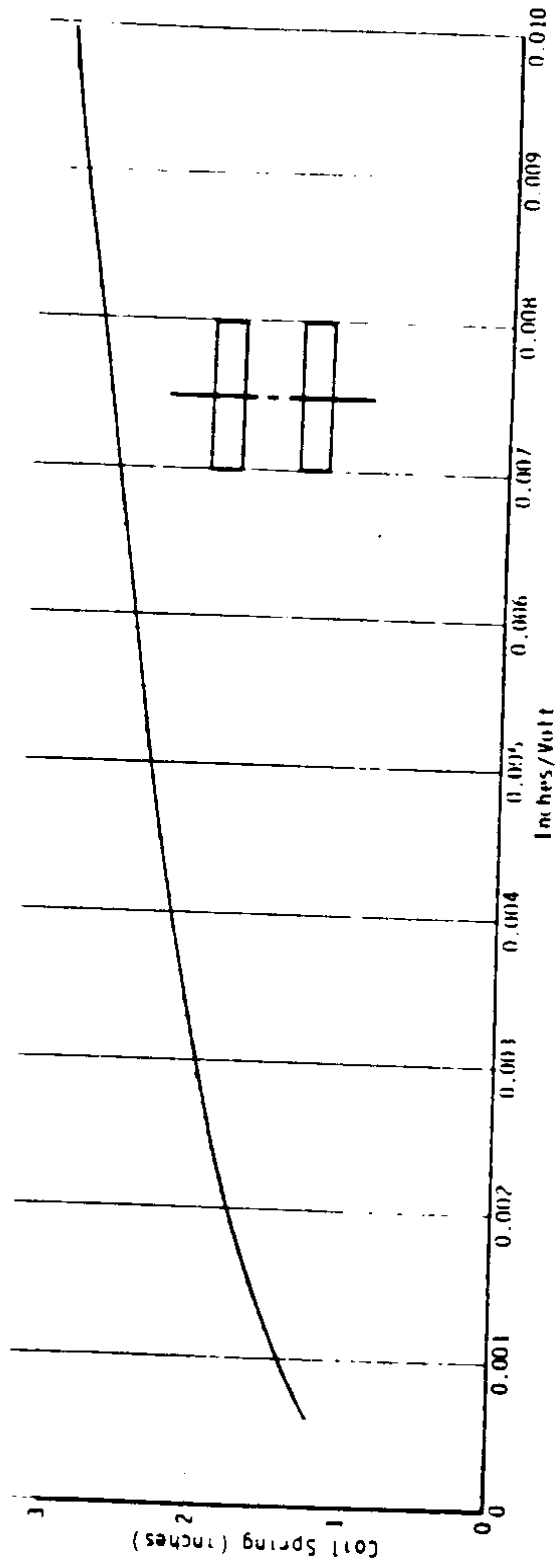

1 cm = 0.394 in

Figure 22 Coil Spacing vs. Inches Per Volt for One Inch Diameter Bison Strain Coils (Parallel Configuration and Maximum Sensitivity)

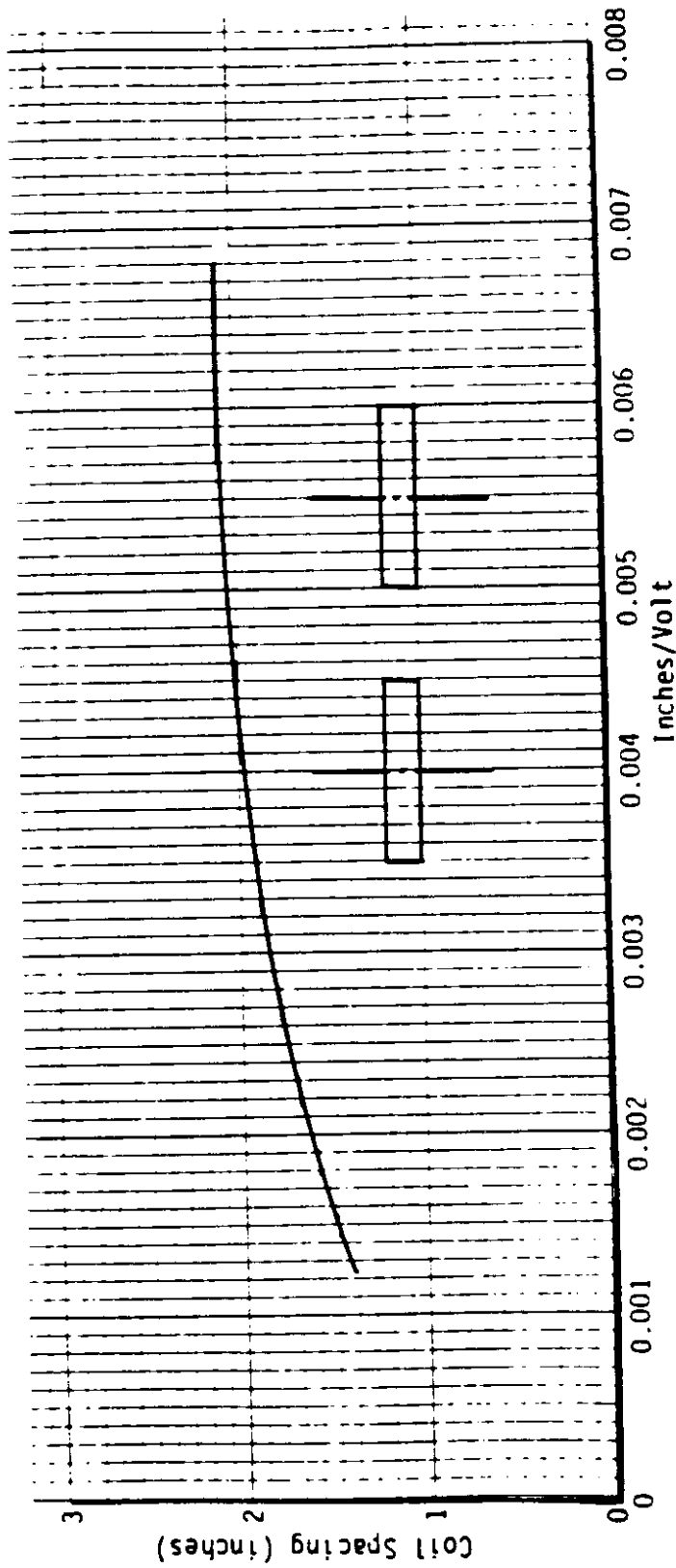
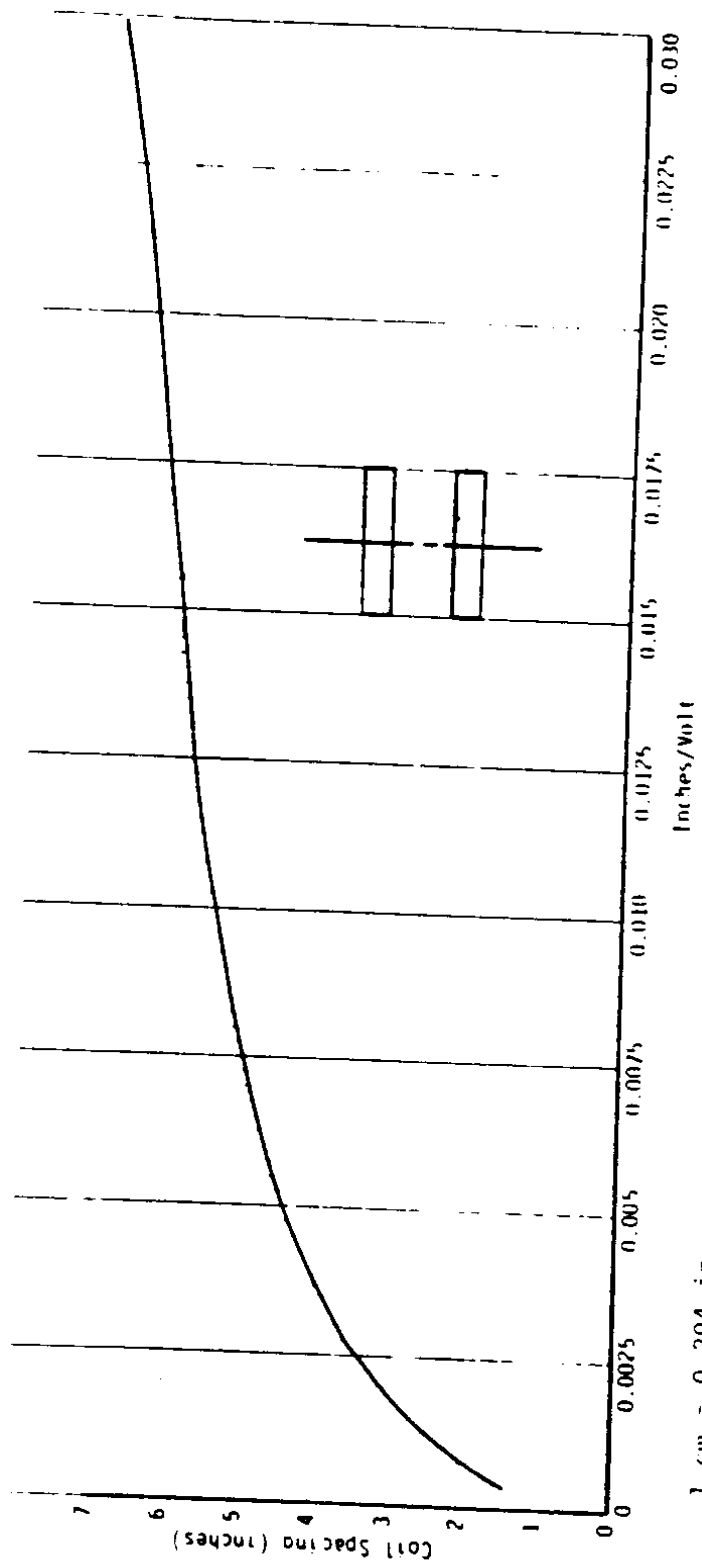
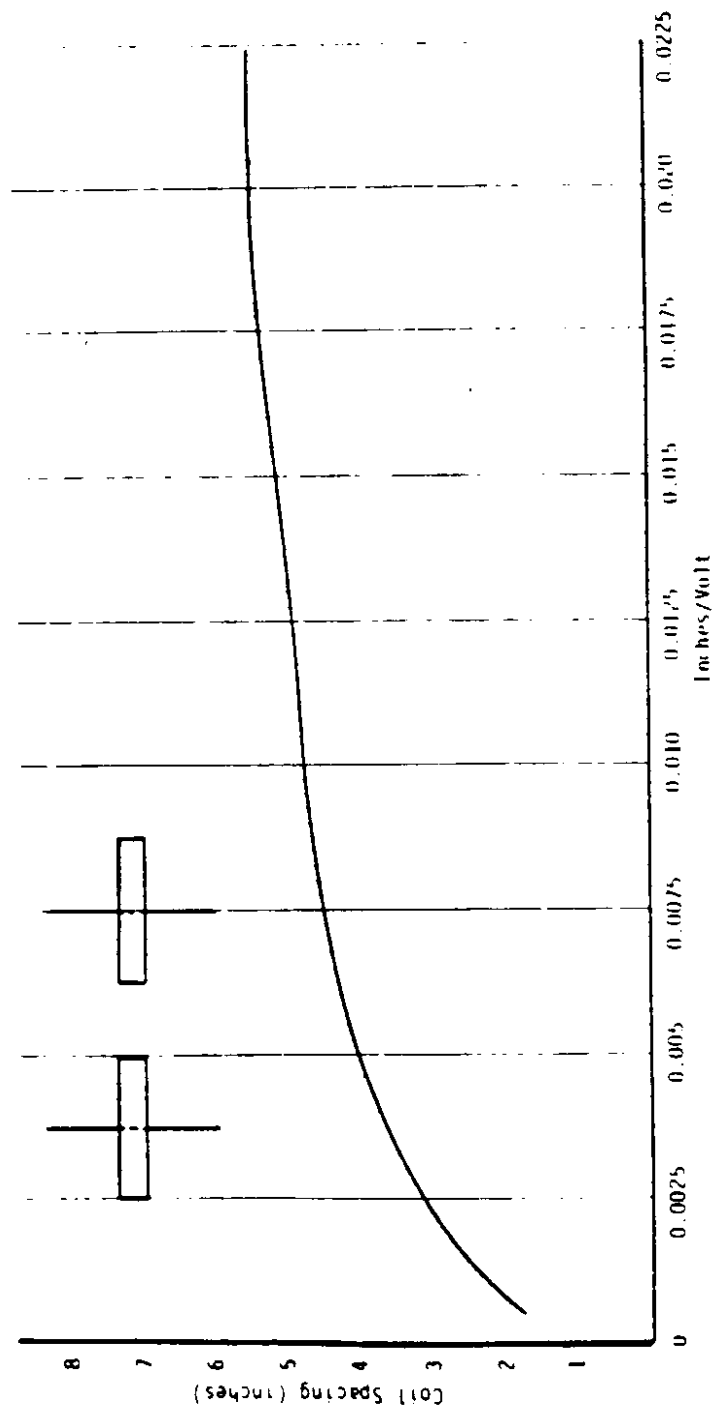

Figure 23 Coil Spacing vs. Inches Per Volt for One Inch Diameter Bison Strain Coils (Coplanar Configuration and Maximum Sensitivity)



1 cm = 0.394 in

Figure 24 Coil Spacing vs. Inches Per Volt for Two Inch Diameter Bison Strain Coils (Parallel Configuration and Maximum Sensitivity)



1 cm = 0.394 in

Figure 25 Coil Spacing vs. Inches Per Volt for Two Inch Diameter Bison Strain Coils (Coplanar Configuration and Maximum Sensitivity)

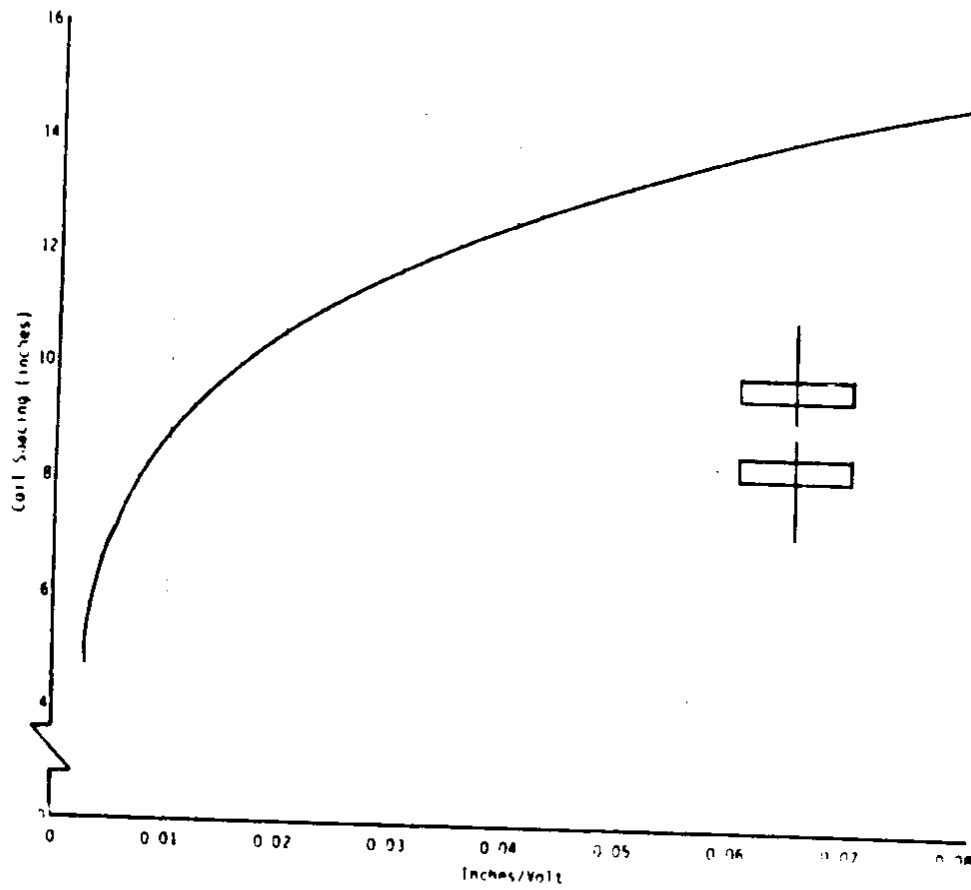

1 cm = 0.394 in

Figure 26 Coil Spacing vs. Inches Per Volt for Four Inch Diameter Bison Strain Coils (Parallel Configuration and Maximum Sensitivity)

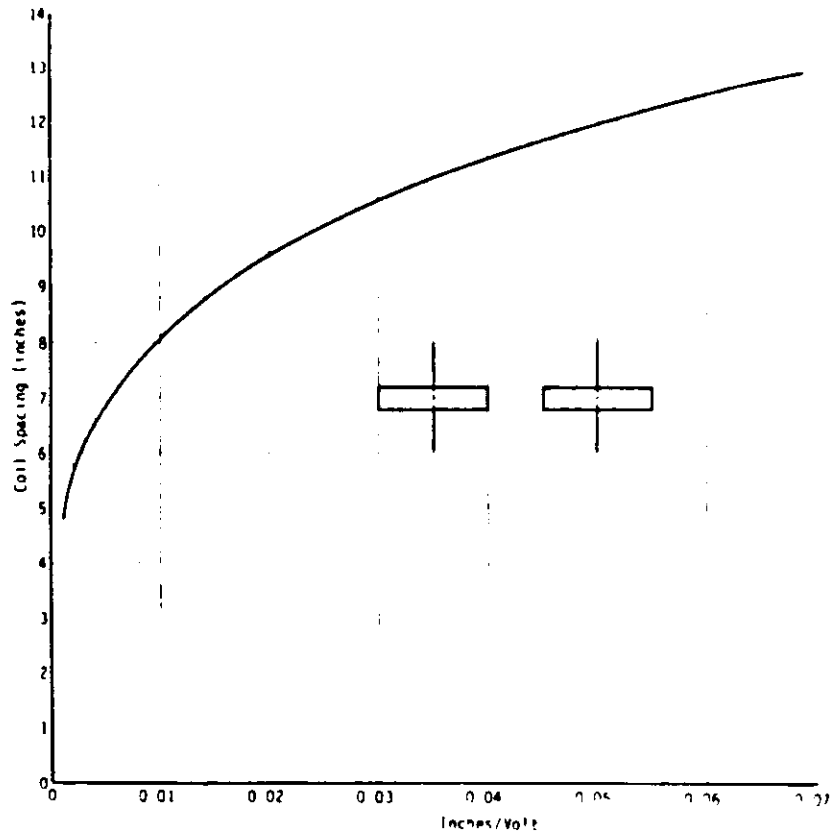

1 cm = 0.394 in

Figure 27 Coil Spacing vs. Inches Per Volt for Four Inch Diameter Bison Strain Coils (Coplanar Configuration and Maximum Sensitivity)

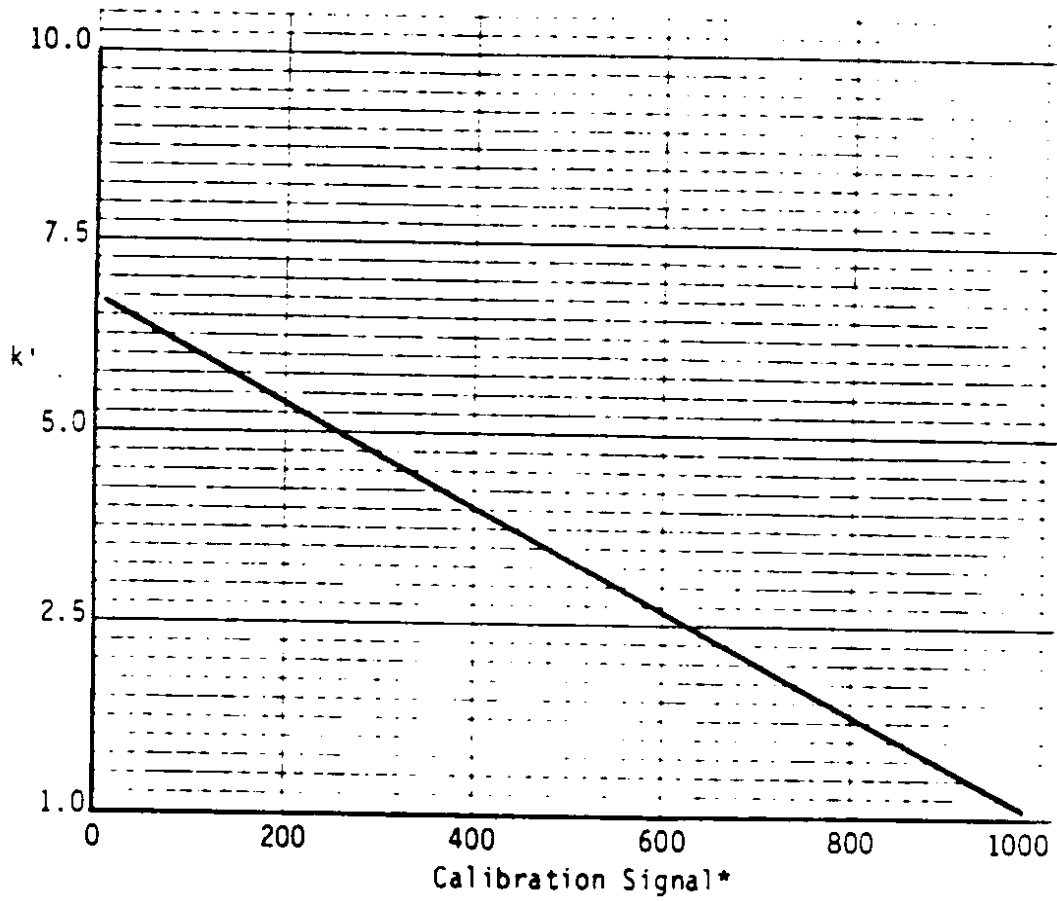

Figure 28 k' vs. Calibration Signal for One Inch Diameter Bison Strain Coils (Parallel and Coplanar Configuration)

*Note: Calibration signal = 1000 maximum sensitivity.

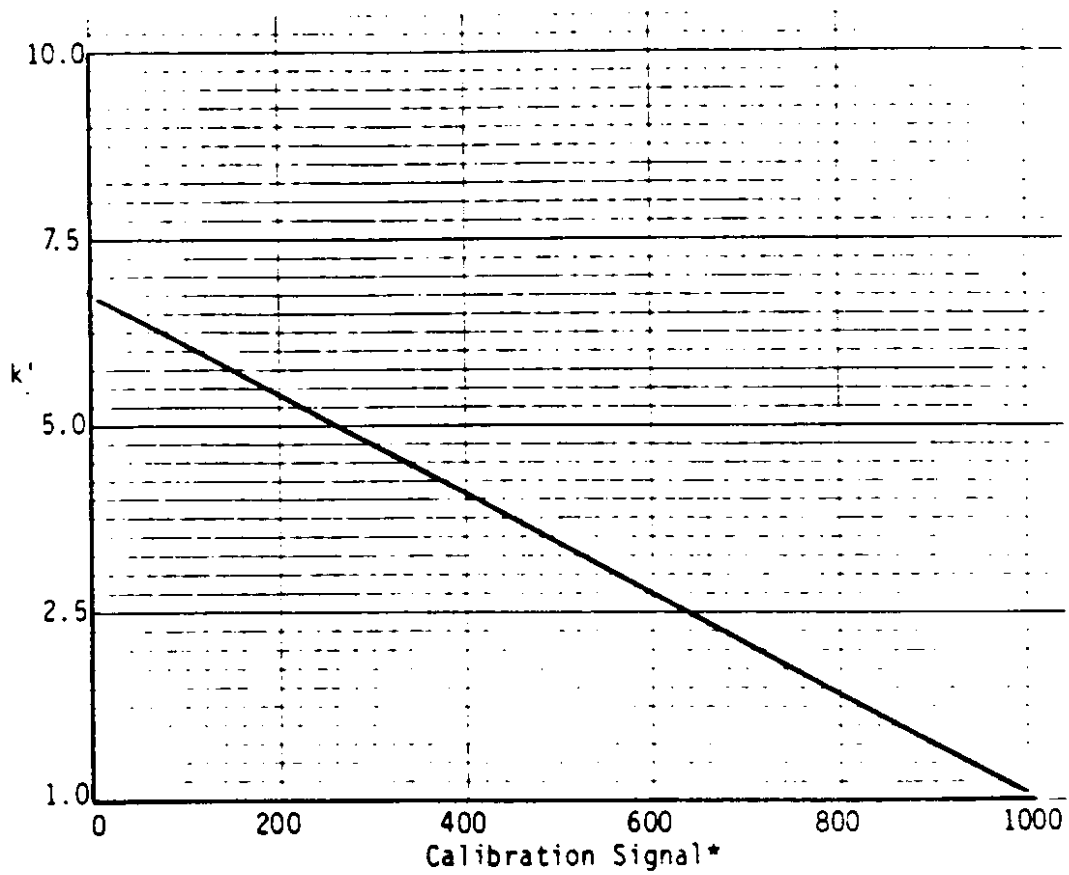

Figure 29 k' vs. Calibration Signal for Two Inch Diameter Bison Strain Coils (Parallel and Coplanar Configuration)

*Note: Calibration signal = 1000 maximum sensitivity.

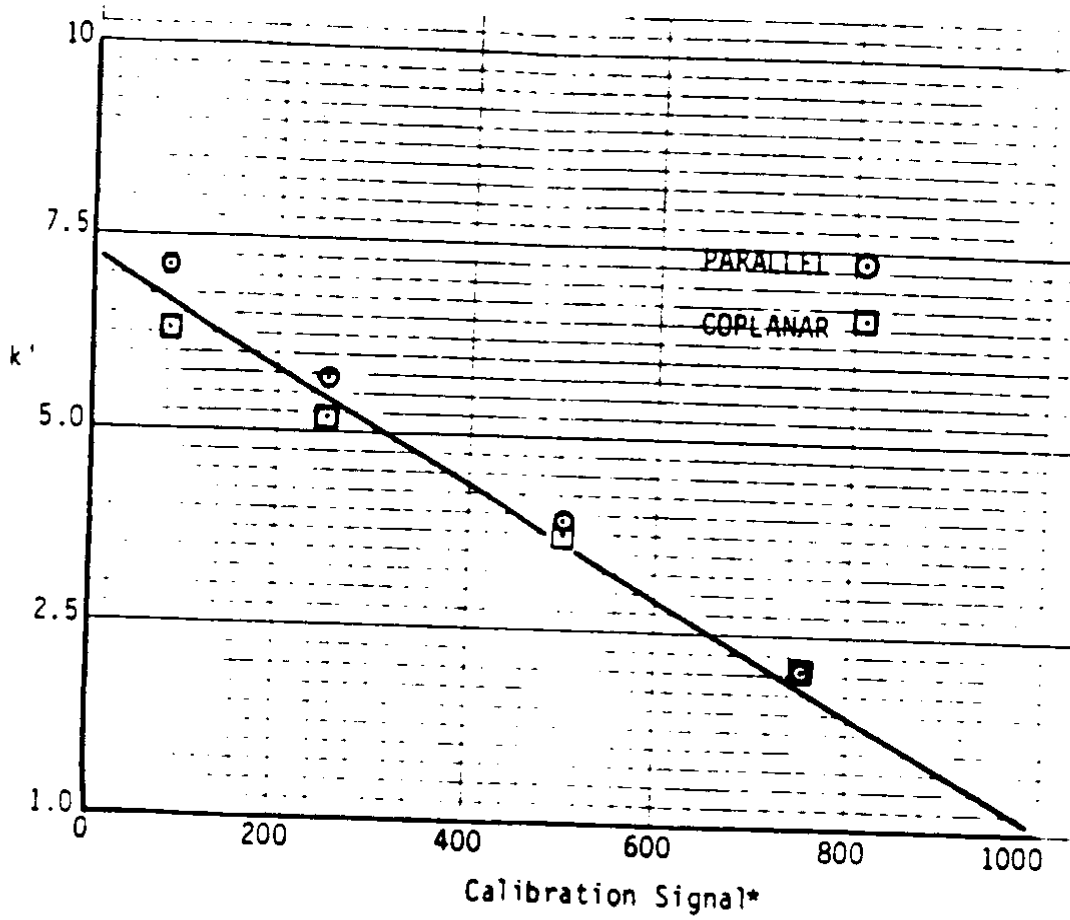

Figure 30 k' vs. Calibration Signal for Four Inch Diameter Bison Strain Coils (Parallel and Coplanar Configuration)

*Note: Calibration signal = 1000 maximum sensitivity.

1. Coil Spacing vs. Amplitude

(a) One inch diameter Bison coils

(i) Parallel

$$\text{Range 1: CS} = 0.79787 + 1.471(10^{-4})(A) + 1.306(10^{-6})(A^2) \\ - 2.1778(10^{-9})(A^3) + 1.5251(10^{-12})(A^4)$$

$$R^2 = 1.000, \text{ RMSE} = 0.00354$$

$$\text{Range 2: CS} = 1.5145 - 5.2(10^{-5})(A) + 2.623(10^{-6})(A^2) \\ - 3.9865(10^{-9})(A^3) + 2.5646(10^{-12})(A^4)$$

$$R^2 = 1.000, \text{ RMSE} = 0.00602$$

$$\text{Range 3: CS} = 2.17169 + 7.983(10^{-4})(A) - 4.40(10^{-7})(A^2) \\ + 1.074(10^{-9})(A^3)$$

$$R^2 = 1.000, \text{ RMSE} = 0.00306$$

(ii) Coplanar

Range 1: Not available

$$\text{Range 2: CS} = 1.54262914 - 6.267(10^{-4})(A) \\ + 1.24(10^{-6})(A^2)$$

$$R^2 = 1.000, \text{ RMSE} = 0.0$$

$$\text{Range 3: CS} = 1.82771935 + 2.645(10^{-4})(A) \\ + 6.6(10^{-7})(A^2)$$

$$R^2 = 1.000, \text{ RMSE} = 0.00037$$

(b) Two inch diameter Bison coils

(i) Parallel

$$\text{Range 1: CS} = 1.184 + 4.801(10^{-3})(A) - 7.083(10^{-6})(A^2) \\ + 4.8172(10^{-9})(A^3)$$

$$R^2 = 1.000, \text{ RMSE} = 0.00857$$

$$\text{Range 2: CS} = 3.4901 + 4.92(10^{-4})(A) + 3.588(10^{-6})(A^2) \\ - 5.6325(10^{-9})(A^3) + 4.1549(10^{-12})(A^4)$$

$$R^2 = 1.000, \text{ RMSE} = 0.00747$$

Figure 31a Bison Calibration - Regression Equ.

$$\text{Range 3: CS} = 5.0548 + 2.51(10^{-4})(A) + 6.34(10^{-6})(A^2) - 1.02(10^{-8})(A^3) + 6.8685(10^{-12})(A^4)$$

$$R^2 = 1.000, \text{ RMSE} = 0.0163$$

(ii) Coplanar

$$\text{Range 1: CS} = 3.14153394 - 2.33295(10^{-3})(A) + 2.87(10^{-6})(A^2)$$

$$R^2 = 1.000, \text{ RMSE} = 0.0$$

$$\text{Range 2: CS} = 2.97441623 + 1.74196(10^{-3})(A) + 2.37(10^{-6})(A^2)$$

$$R^2 = 1.000, \text{ RMSE} = 0.00284$$

$$\text{Range 3: CS} = 4.19000098 + 1.39654(10^{-3})(A) - 7.8(10^{-7})(A^2)$$

$$R^2 = 1.000, \text{ RMSE} = 0.00760$$

(c) Four inch diameter Bison coils

(i) Parallel

$$\text{Range 1: CS} = 3.5276 + 4.129(10^{-3})(A) - 6.16(10^{-6})(A^2) + 5.9608(10^{-9})(A^3)$$

$$R^2 = 0.999, \text{ RMSE} = 0.0345$$

$$\text{Range 2: CS} = 7.1017 - 4.06(10^{-4})(A) + 1.297(10^{-5})(A^2) - 1.973(10^{-8})(A^3) + 1.2690(10^{-11})(A^4)$$

$$R^2 = 1.000, \text{ RMSE} = 0.0210$$

$$\text{Range 3: CS} = 9.378 + 8.54(10^{-3})(A) - 1.421(10^{-5})(A^2) + 1.4302(10^{-8})(A^3)$$

$$R^2 = 0.999, \text{ RMSE} = 0.114$$

(ii) Coplanar

$$\text{Range 1: CS} = 5.130 - 2.375(10^{-3})(A) + 3.75(10^{-6})(A^2)$$

Figure 31b Bison Calibration - Regression Equ.

$$\begin{aligned} \text{Range 2: } CS &= 6.63532513 - 1.74969(10^{-3})(A) \\ &\quad + 1.150(10^{-5})(A^2) - 1.0(10^{-8})(A^3) \\ R^2 &= 1.000, \text{ RMSE} = 0.00447 \end{aligned}$$

$$\begin{aligned} \text{Range 3: } CS &= 8.22638138 + 5.08093(10^{-3})(A) \\ &\quad - 5.86(10^{-6})(A^2) + 1.0(10^{-8})(A^3) \\ R^2 &= 1.000, \text{ RMSE} = 0.0 \end{aligned}$$

2. Inches per Volt vs Coil Spacing

(a) One inch diameter Bison coils

(i) Parallel

$$\begin{aligned} IV &= -3.3927(10^{-4}) + 3.2517(10^{-4})(CS) - 3.6854(10^{-4})(CS^2) \\ &\quad + 5.4961(10^{-4})(CS^3) \\ R^2 &= 0.997, \text{ RMSE} = 0.00024 \end{aligned}$$

(ii) Coplanar

$$\begin{aligned} IV &= -1.70526657 + 3.67436707(CS) - 2.93789420(CS^2) \\ &\quad + 1.03293895(CS^3) - 1.3442790(10^{-1})(CS^4) \\ R^2 &= 0.990, \text{ RMSE} = 0.00050 \end{aligned}$$

(b) Two inch diameter Bison coils

(i) Parallel

$$\begin{aligned} IV &= -6.2544(10^{-4}) + 1.63682(10^{-3})(CS) - 7.7564(10^{-4})(CS^2) \\ &\quad + 1.5644(10^{-4})(CS^3) \\ R^2 &= 0.998, \text{ RMSE} = 0.00034 \end{aligned}$$

(ii) Coplanar

$$\begin{aligned} IV &= -1.395128(10^{-2}) + 1.314043(10^{-2})(CS) - 4.13193(10^{-3})(CS^2) \\ &\quad + 5.1743(10^{-4})(CS^3) \\ R^2 &= 0.998, \text{ RMSE} = 0.00040 \end{aligned}$$

Figure 31c Bison Calibration - Regression Equ.

(c) Four inch diameter Bison coils

(i) Parallel

$$IV = -5.31776(10^{-3}) + 3.97848(10^{-3})(CS) - 8.5165(10^{-4})(CS^2) \\ + 7.715(10^{-5})(CS^3) - 9.9(10^{-7})(CS^4)$$

$$R^2 = 1.000, \text{ RMSE} = 0.00030$$

(ii) Coplanar

$$IV = -2.88144(10^{-2}) + 1.294754(10^{-2})(CS) \\ - 2.04106(10^{-3})(CS^2) + 1.2767(10^{-4})(CS^3)$$

$$R^2 = 0.997, \text{ RMSE} = 0.00011$$

Figure 31d Bison Calibration - Regression Equ.

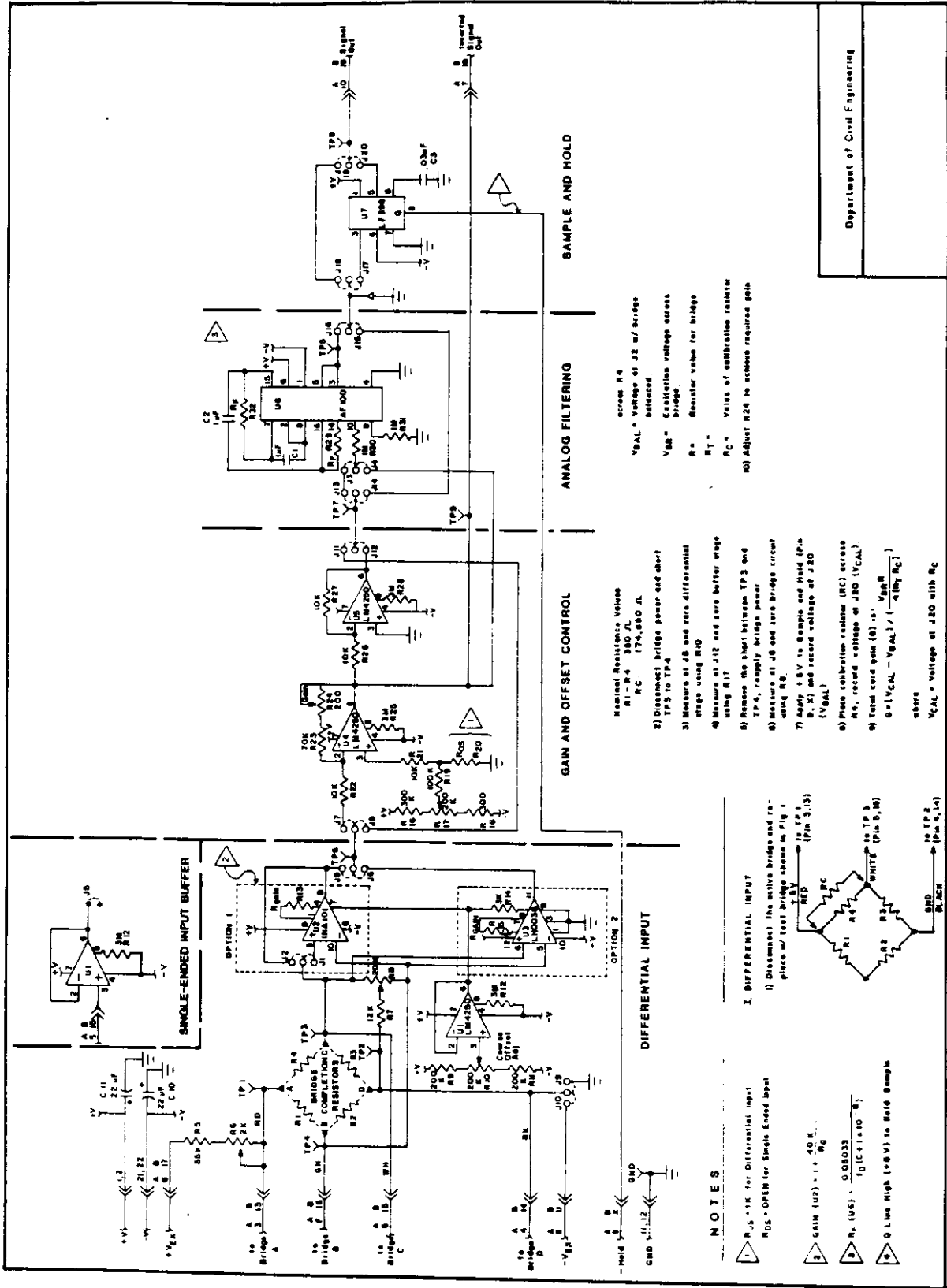
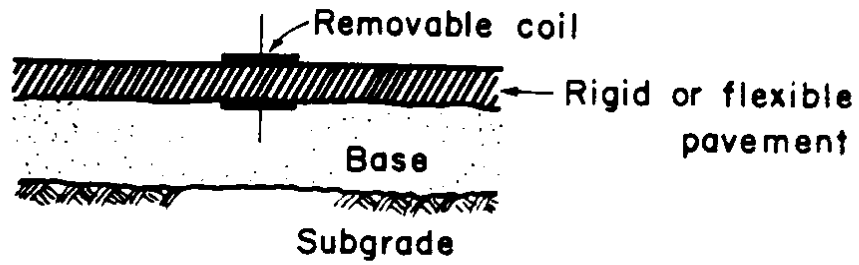
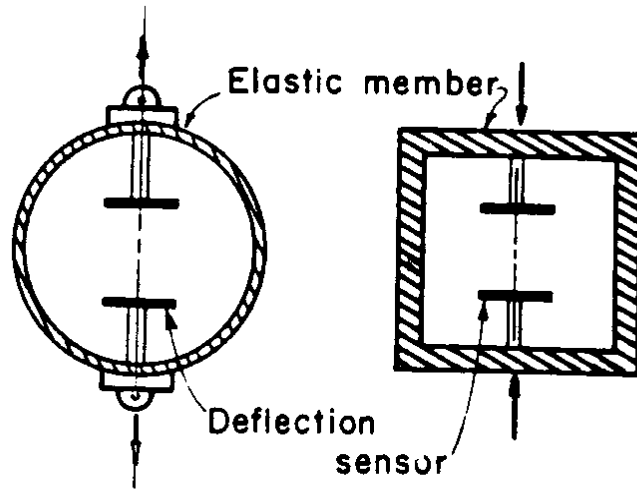

Figure 32 Suggested Signal Conditioning Electronics



a) Pavement thickness measurement



b) Load cells

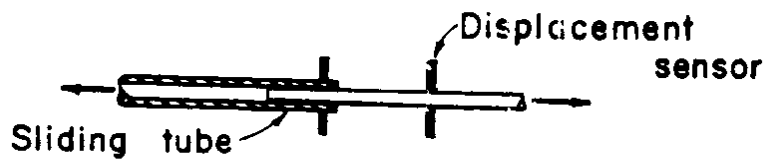

c) Extensometer readout

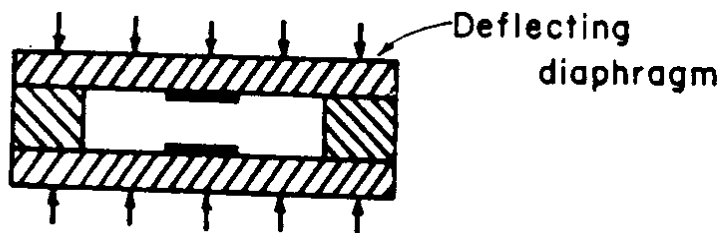

d) Stress or pressure gauge

Figure 34 Applications for Strain Gage Other Than in Soil

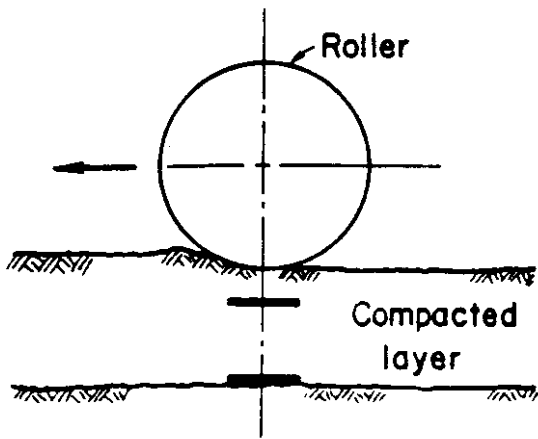

a) Compaction

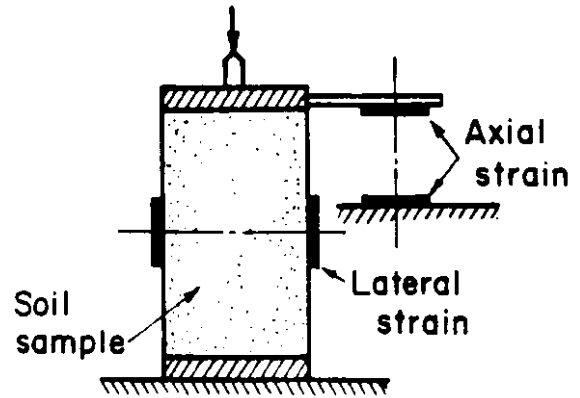

b) Triaxial Tests

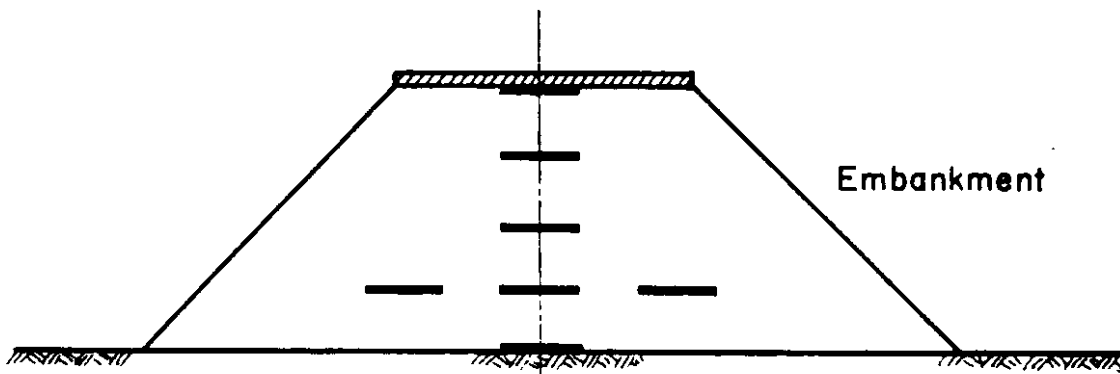

Sensors indicate consolidation, swelling and shrinkage.

c) Embankment Strains

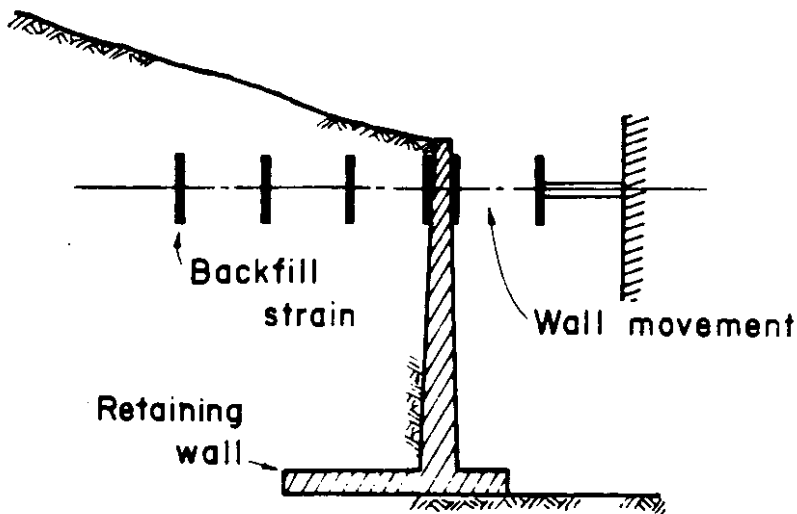

d) Backfill movements

Figure 35 Applications for Strain Gage Embedded in Soil

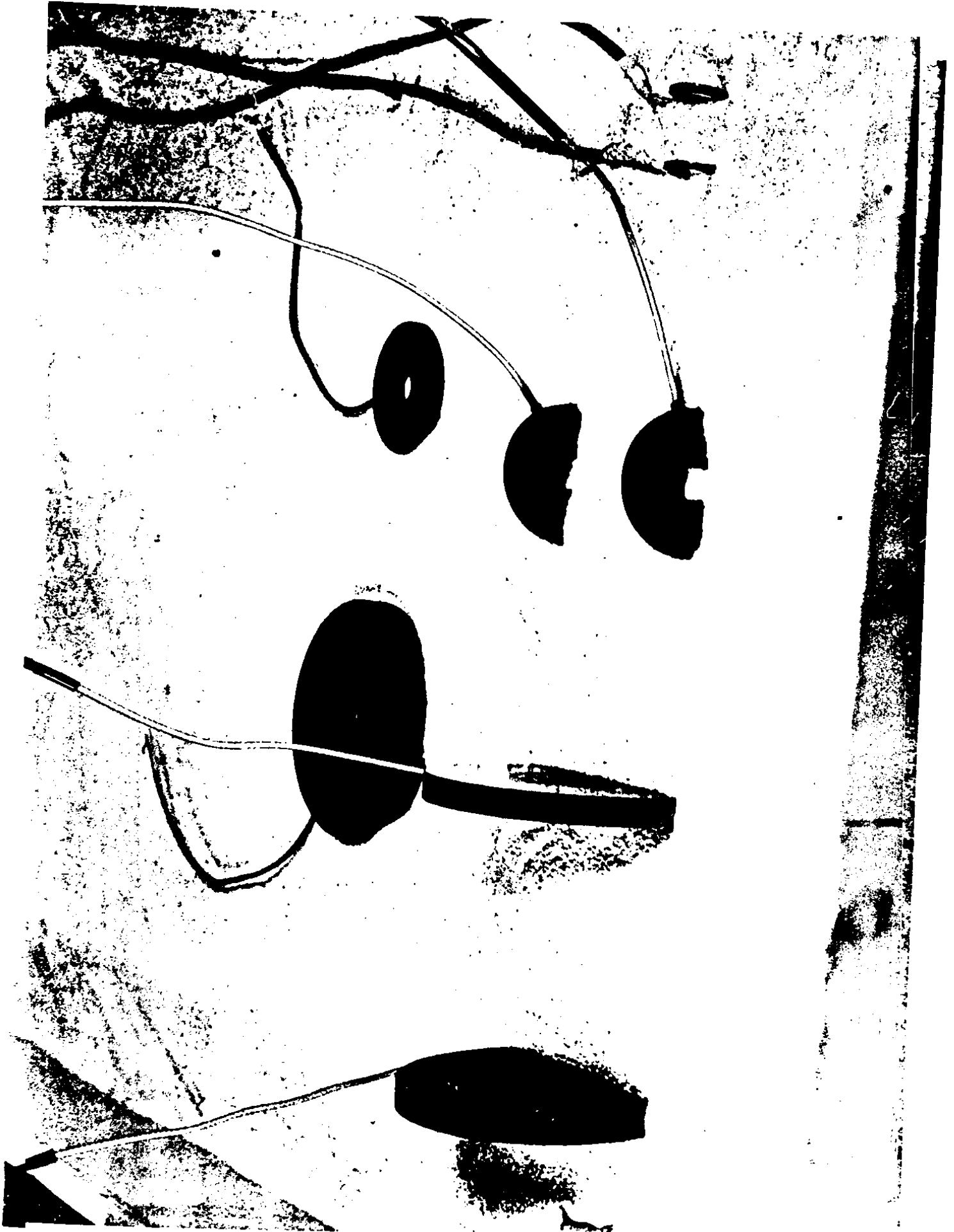

Figure 36 One-, Two- and Four-inch Diameter Sensors

SECTION VIII

APPENDICES

APPENDIX A
EXTENSOMETER DETAILS

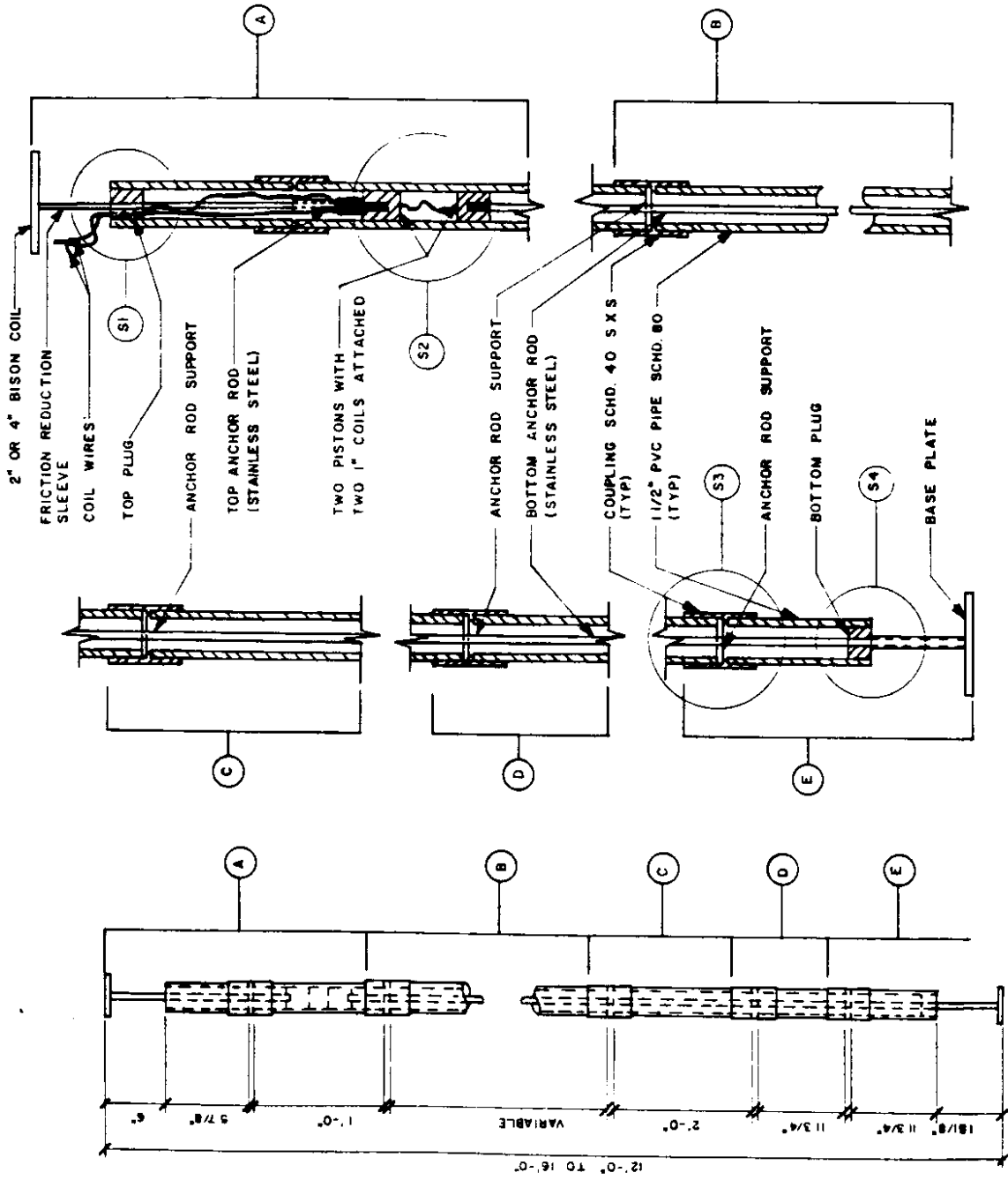

Figure 1A Extensometer - General Detail

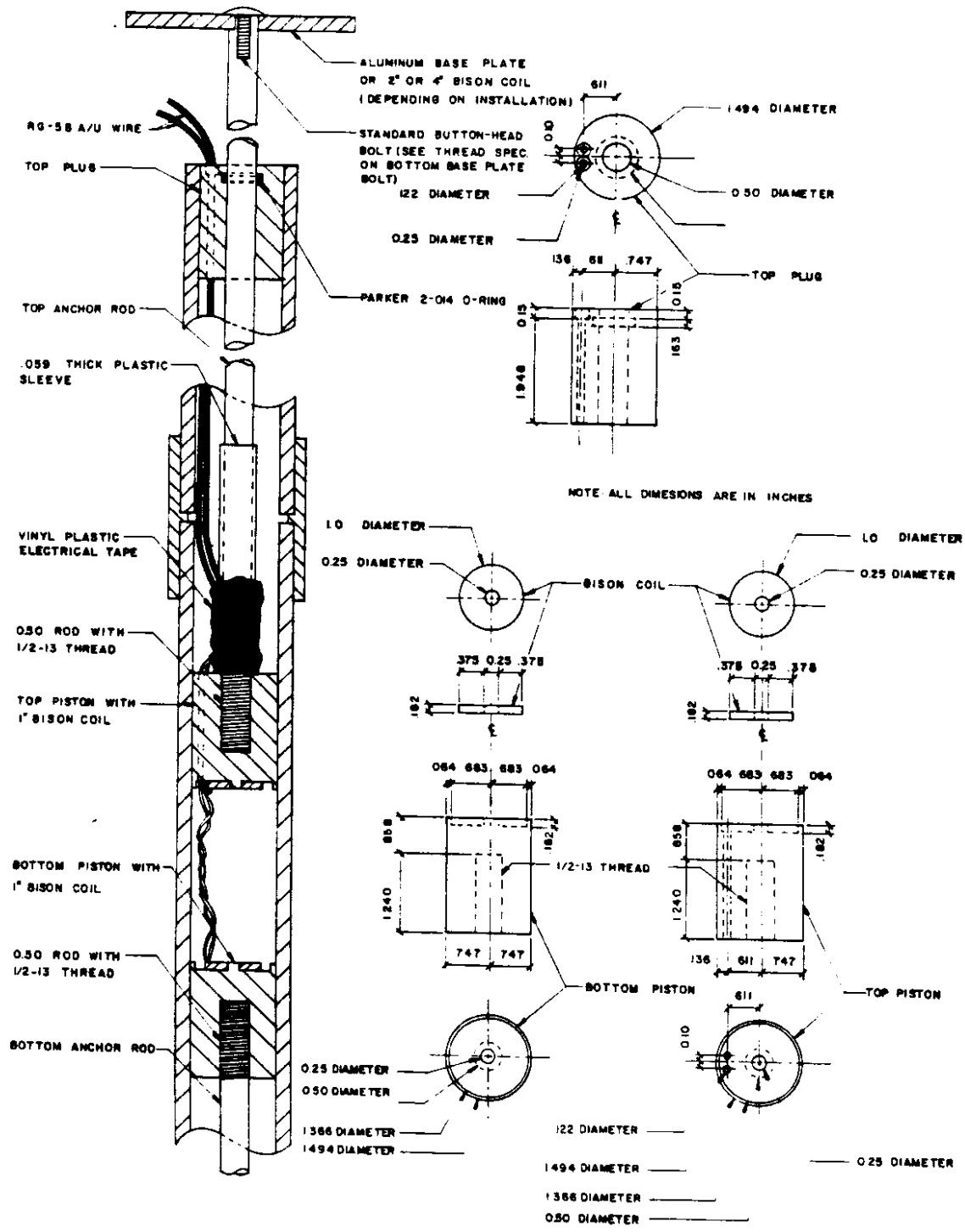
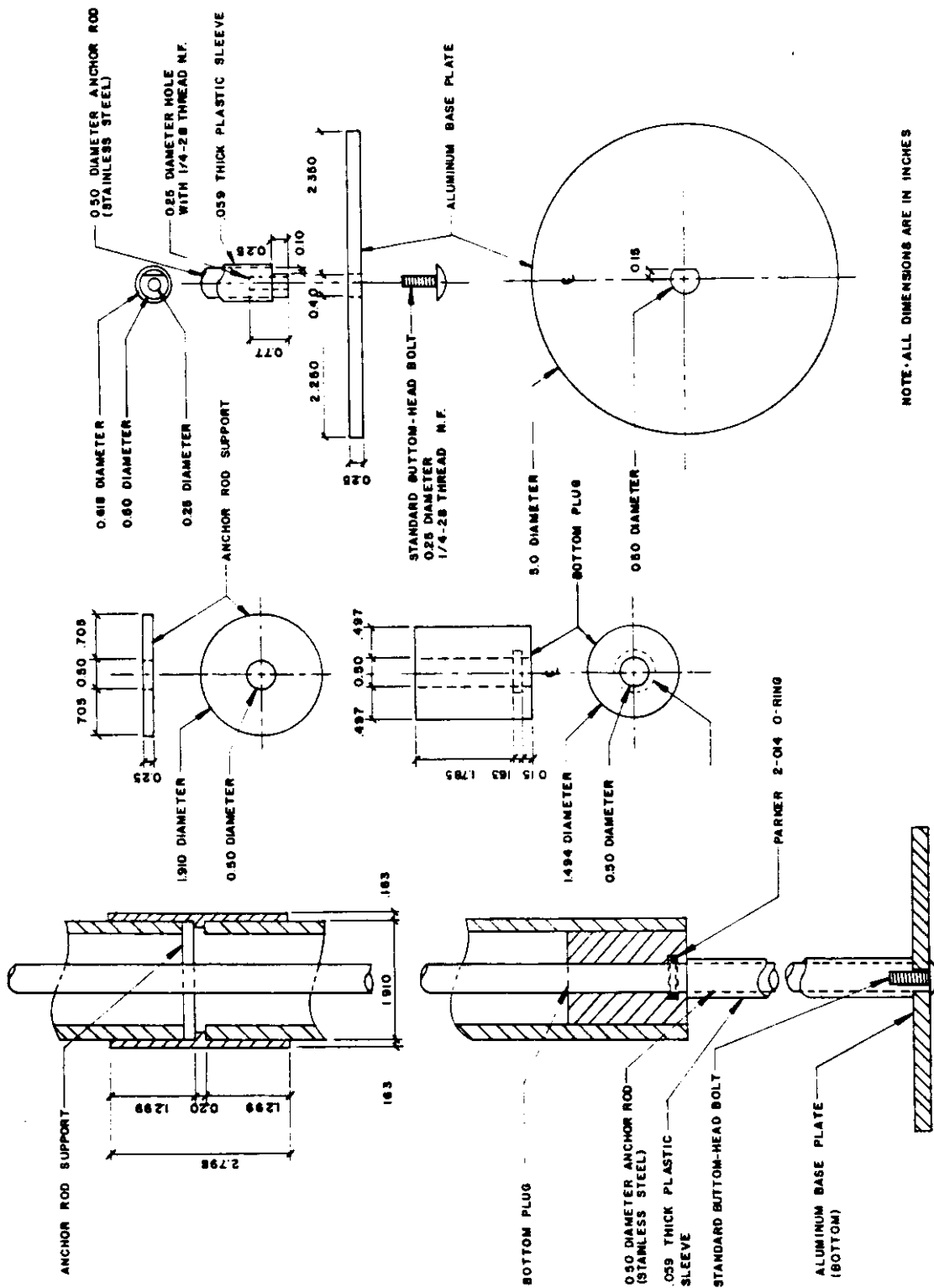

Figure 2A Extensometer - Bison Coil Sensor Detail



NOTE: ALL DIMENSIONS ARE IN INCHES

Figure 3A Extensometer - End Plate and Guide Detail

APPENDIX B

NICHOLET - IBM - PC/XT SOFTWARE INTERFACE

```

1 REM      13 FEB 1985
2 REM      THIS PROGRAM READS VALUES FROM A NICOLET 4094 DIGITAL
3 REM      OSCILLOSCOPE, CONVERTS THE VALUES TO ACTUAL TIME SERIES
4 REM      VOLTAGES, THEN WRITES THE VALUES IN A RANDOM FILE ON
5 REM      FLOPPY DISK.  THE RANDOM FILE IS A SERIES OF FOUR BYTE
6 REM      RECORDS.  THE FIRST RECORD IS THE START TIME, IN SECONDS;
7 REM      THE SECOND RECORD IS THE TIME INCREMENT IN SECONDS.  ALL
8 REM      FOLLOWING RECORDS ARE VOLTAGES, BEGINNING WITH THE
9 REM      START TIME VOLTAGE AND PROCEEDING SEQUENTIALLY.  A FULL
10 REM     TRACE OF 15872 READINGS WILL REQUIRE A 63496 BYTE FILE.
11 REM
12 REM
13 REM     THE PROGRAM OPERATES OFF A MENU, WHICH APPEARS UPON
14 REM     EXECUTING RUN.  NOTE THAT THE "WAVEFORM" ROUTINE MUST
15 REM     BE CALLED BEFORE ANY DATA CAN BE LOADED.
16 REM
17 REM
18 REM             PRINT OPTIONS
19 REM
20 DIM NDAT$(32),NSET$(32)
30 OPEN "COM1:4800,N,8,1,LF" AS #1 LEN=4096
35 WRITE#1,">"
40 CLS
50 PRINT:PRINT TAB(21)"MAKE SCOPE BEEP ----- B"
55 PRINT:PRINT TAB(21)"LOAD FILE FROM DISK ----- L"
60 PRINT:PRINT TAB(21)"GET WAVEFORM INFORMATION ----- W"
65 PRINT:PRINT TAB(21)"GET DATA ----- D"
80 PRINT:PRINT TAB(21)"CALL L,W,D IN ORDER ----- O"
90 PRINT:PRINT TAB(21)"ENTER COMMAND FROM KEYBOARD ----- P"
95 PRINT:PRINT TAB(21)"EXIT ----- X"
96 PRINT:PRINT
100 REM
101 REM             SELECT OPTIONS
102 REM
110 S$=INKEY$:IF S$="" THEN 110
150 IF S$="B" THEN WRITE#1,"B":GOTO 110
155 IF S$="L" THEN GOSUB 300:GOTO 40
160 IF S$="W" THEN GOSUB 400:GOTO 40
165 IF S$="D" THEN GOSUB 500:GOTO 40
180 IF S$="O" THEN GOSUB 300:GOSUB 400:GOSUB 500:GOTO 40
190 IF S$="P" THEN GOSUB 200:GOTO 40
195 IF S$="X" THEN CLOSE:END
199 GOTO 110
200 REM
201 REM             COMMANDS FROM THE KEYBOARD
202 REM
210 INPUT;"ENTER COMMAND: ",S$:PRINT
215 IF S$="" THEN RETURN
220 WRITE#1,S$
230 WHILE NOT EOF(1):S$=INPUT$(LOC(1),#1):PRINT S$:WEND
299 GOTO 900

```



```

300 REM
301 REM          LOAD ROUTINE
302 REM
310 INPUT;"LOAD FILE.  ENTER FILE NUMBER:  ",S$:PRINT:PRINT
315 IF S$="" THEN RETURN
320 NFILE=VAL(S$):IF NFILE<0 THEN WRITE#1,"B":GOTO 310
330 IF NFILE>20 THEN WRITE#1,"B":GOTO 310
340 S$="R,0,"+S$+",0":WRITE#1,S$
370 PRINT"WAIT UNTIL RECALL LIGHT ON SCOPE IS OUT, THEN PRESS ANY KEY."
399 NWAWS=0:GOTO 920
400 REM
401 REM          WAVEFORM ROUTINE
402 REM
410 CLS
411 IF NFILE=0 THEN PRINT"MUST LOAD FILE FIRST":WRITE#1,"B":GOTO 499
412 WRITE#1,"W"
415 S$=INPUT$(4,#1):IF MID$(S$,3,1)<>CHR$(13) THEN 425
420 A$=LEFT$(S$,2):GOTO 415
425 IF A$<>"00" THEN PRINT"ERROR CODE IN W = "A$:GOTO 499
430 A$=LEFT$(S$,2):NWAWS=VAL(A$)
435 PRINT"FILE "NFILE".      THE NUMBER OF WAVEFORMS = "NWAWS
440 S$=RIGHT$(S$,2)+INPUT$(13,#1)
445 PRINT:PRINT"WAVE NO.      NO. OF DATA PTS      NORM. SET NO."
450 FOR I=1 TO NWAWS
455 IF I<>1 THEN S$=INPUT$(15,#1)
460 NW=VAL(LEFT$(S$,2)):IF NW<>I THEN PRINT"BAD WAVEFORM MATCH":GOTO 499
465 NDAT$(I)=MID$(S$,3,6):NSET$(I)=MID$(S$,9,2)
475 PRINT "  "I,"  "NDAT$(I),"      "NSET$(I):IF I<>15 THEN GOTO 488
480 PRINT:PRINT"PRESS ANY KEY TO CONTINUE"
485 S$=INKEY$:IF S$="" THEN 485
488 NEXT I
499 GOTO 900
500 CLS
501 REM          GET DATA, SET UP FILE
502 REM
510 IF NWAWS=1 THEN S$="1":GOTO 530
520 IF NWAWS=0 THEN PRINT"MUST CALL W FIRST":WRITE#1,"B":GOTO 900
525 PRINT"FILE NUMBER "NFILE".";
530 INPUT;"ENTER THE FILE NAME FOR STORAGE:  ",S$:PRINT:PRINT
540 IF S$="" THEN RETURN
550 DNAM$=S$:OPEN DNAM$ AS #2 LEN=4
580 FIELD #2,4 AS RS$
590 PRINT"FILE NAME = "DNAM$:PRINT

```

```

600 REM
601 REM          GET DATA, GET NORMALIZATION SET
602 REM
610 IF NWAWS=1 THEN S$="1":GOTO 625
620 INPUT;"ENTER THE WAVEFORM NO:  ",S$:PRINT:PRINT
622 IF S$="" THEN RETURN
625 NW=VAL(S$):IF NW>NWAWS THEN WRITE#1,"B":GOTO 620
630 IF NW<1 THEN WRITE#1,"B":GOTO 620
635 S$="N,"+NSET$(NW):WRITE#1,S$:WRITE#1,S$
640 S$=INPUT$(4,#1):IF MID$(S$,3,1)<>CHR$(13) THEN 648
645 A$=LEFT$(S$,2):GOTO 640
648 S$=S$+INPUT$(48,#1)
650 IF A$<>"00" THEN PRINT"ERROR CODE IN N = "A$:GOTO 900
660 WVAL=VAL(LEFT$(S$,1)):SWSIZ=VAL(MID$(S$,2,1)):CHNUM=VAL(MID$(S$,3,1))
665 DISCH=VAL(MID$(S$,4,1)):VNORM=VAL(MID$(S$,5,9)):HNORM=VAL(MID$(S$,14,9))
670 VZERO=VAL(MID$(S$,23,6)):HZERU=VAL(MID$(S$,29,6))
675 HZERL=VAL(MID$(S$,35,6))
680 PRINT  WVAL,SWSIZ,CHNUM,DISCH,VNORM,HNORM,VZERO,HZERU,HZERL
690 WHILE NOT EOF(1):S$=INPUT$(LOC(1),#1):WEND
700 REM
701 REM          GET DATA, ESTABLISH TRANSFER PARAMETERS
702 REM
710 PRINT:PRINT"FILE NUMBER "NFILE;
712 PRINT".  WAVEFORM NUMBER "NW".  TOTAL POINTS = "NDAT$(NW)
715 MAX%=512:PRINT:PRINT
725 S$=STR$(NW):L$="D,0,"+RIGHT$(S$,LEN(S$)-1)+", "
730 INPUT;"ENTER STARTING POINT (A = ALL POINTS):  ",S$:PRINT
735 IF S$="" THEN CLOSE 2:RETURN
740 IF S$<>"A" THEN GOTO 750
745 S$=NDAT$(NW):TOT%=VAL(S$):ST%=0:INC%=1:GOTO 760
750 INPUT;"ENTER THE TOTAL NUMBER OF POINTS:  ",S$:PRINT:TOT%=VAL(S$)
755 INPUT;"ENTER THE INCREMENT:  ",S$:PRINT:INC%=VAL(S$)
760 STEPS%=INT(TOT%/MAX%):RMD%=TOT%-MAX%*STEPS%

```

```

800 REM
801 REM          GET DATA, CONVERT TO VOLTAGE AND TIME
802 REM          D=(VAL(LEFT$(S$,6))-VZERO)*VNORM
803 REM          T=(KNT%-KK*HZERU+HZERL)*HNORM
804 REM
810 STT=(ST%-65536!*HZERU+HZERL)*HNORM:INCC=INC%*HNORM
815 PRINT"START TIME = "STT".      DELTA TIME = "INCC"."
820 LSET RS%=MKS$(STT):PUT #2
822 LSET RS%=MKS$(INCC):PUT #2
825 FOR I=0 TO STEPS%
830 S%=STR$((I)*MAX%*INC%)
835 C%=L$+RIGHT$(S$,LEN(S$)-1)+", "
840 IF I<STEPS% THEN S%=STR$(MAX%)
845 IF I=STEPS% THEN S%=STR$(RMD%)
847 IF VAL(S$)=0 THEN GOTO 899
850 C%=C%+RIGHT$(S$,LEN(S$)-1)+", "
855 S%=STR$(INC%):C%=C%+RIGHT$(S$,LEN(S$)-1)
865 WRITE#1,C$
866 PRINT"STEP "I,C$
870 S%=INPUT$(4,#1):IF MID$(S$,3,1)<>CHR$(13) THEN 880
875 A%=LEFT$(S$,2):GOTO 870
880 IF A%<>"00" THEN PRINT"ERROR CODE IN D = "A$:GOTO 899
882 S%=S%+INPUT$(2,1)
885 WHILE NOT EOF(1):NPT%=LOC(1):IF NPT%>6 THEN NPT%=6
890 D=(VAL(LEFT$(S$,6))-VZERO)*VNORM:LSET RS%=MKS$(D):PUT #2
891 S%=INPUT$(NPT%,1):WEND
895 NEXT I
899 WRITE#1,"B":CLOSE 2:GOTO 900
900 REM
901 REM          EMPTY BUFFER, RETURN TO MAIN MENU
902 REM
910 PRINT:PRINT"PRESS ANY KEY WHEN FINISHED":PRINT
920 S%=INKEY$:IF S%="" THEN 920
930 IF LOC(1)=0 THEN RETURN
940 S%=INPUT$(LOC(1),#1):GOTO 930

```

DIRECT TRANSFER OF SQUEEZING FLOW DATA FROM A
A NICOLET 4094 OSCILLOSCOPE TO A VAX 11/750 COMPUTER

TABLE OF CONTENTS

1. OVERVIEW	1
2. HARDWARE	2
2.1 Arrangement and Connections	2
2.2 Oscilloscope Preparation	2
2.3 Preparation of the VAX 11/750 Computer	2
3. SOFTWARE	3
3.1 Organization and Use of the Program DATATRAN	3
3.2 Transfer of Character Strings	4
3.2.1 Specifications for the Nicolet 4094 Oscilloscope	4
3.2.2 Processing of Strings by the Program DATATRAN	4
REFERENCES	5
APPENDIX THE PROGRAM DATATRAN	6
Flow Chart	7
Listing for the main program	9
Listing for the subroutine ERR	14
Listing for the subroutine INIT	15
Listing for the subroutine OUTSTR	16
Listing for the subroutine INSTR	17

1. OVERVIEW

Force and displacement profiles, obtained in compression flow experiments, were transferred from a Nicolet 4094 oscilloscope to a VAX 11/750 computer for final storage and processing. The oscilloscope was used to acquire and store the experimental data on floppy disks. Then the data acquisition system was transported and connected directly to the VAX computer. Finally, a Fortran code allowed the data to be efficiently transferred to the mainframe computer.

Included in this report are descriptions of the hardware interfaces, the software, and a copy of the code. Attention is given to problems relating to the interface, and it is assumed that the reader has access to available documentation [1,2] on the independent operation of the oscilloscope and the mainframe computer. It is hoped that this report will be of help in the development of systems to transfer data from Nicolet oscilloscopes to VAX computers.

2. HARDWARE

The arrangement, connections, and settings used in this application were all standard with no modifications of hardware required.

2.1 Arrangement and Connections

Data was transferred from the Nicolet 4094 oscilloscope to the VAX 11/750 computer through an RS-232C port normally used for a terminal. A null modem connection was made with no lines jumped.

Access to the VAX software was obtained with the use of a second port and terminal located within the immediate vicinity of the oscilloscope and mainframe computer. It is noted that since a second port was employed, the null modem board, available for use with the oscilloscope, was not required.

2.2 Oscilloscope Preparation

The oscilloscope was prepared for data transmission according to the instructions given in the oscilloscope operation manual [1]. The five DIP switches described in Section 13 were set to provide the following transmission characteristics:

baud rate	9600
parity	none
number of stop bits	one

No other preparations specific to the interface with the mainframe were required.

2.3 Preparation of the VAX 11/750 Computer

John Peterson, the system manager of the chemical engineering VAX 11/750, changed a system privilege to allow the transmission

rate for the RS-232C line between the VAX and the oscilloscope to be varied.

3. SOFTWARE

The Fortran code DATATRAN directs the transfer of two waveforms from the memory of the Nicolet oscilloscope to the VAX computer where they are stored in a data file. The program was tailored for the squeezing flow application, but it could be modified for more general use.

3.1 Organization and Use of the Program DATATRAN

A flow chart and a listing of the program DATATRAN are given in the appendix. The program is not written in a menu style, but the user is allowed to skip selected operations.

The program proceeds as follows:

The user first assigns the terminal port to which the oscilloscope is connected. Then the data of interest is transferred from a floppy disk to the oscilloscope memory using controls on the oscilloscope. Next the user may examine waveform specifications which are described in reference [1]. The first waveform (force) is selected, normalization information is obtained, and the data is transferred to an array. Then the second waveform (displacement) is selected and treated in a similar fashion. Finally, the normalized data sets are written to a file on the VAX. The next run is begun with the transfer of new waveforms to the oscilloscope memory and the above procedure is repeated.

The transfer of two waveforms, involving a combined total of 16,000 data points, is accomplished in approximately 2.5 minutes real time.

3.2 Transfer of Character Strings

The character strings received and transmitted by the oscilloscope may be obtained from the listing of the program DATATRAN, and are described in the oscilloscope operation manual [1].

3.2.1 Specifications for the Nicolet 4094 Oscilloscope

Default assignments were used in all specifications concerning string transmission characteristics, except in the following two cases:

- 1) The record separator delimiter was set to CR/LF (carriage return/linefeed).
- 2) The ASCII format was chosen for the output data.

3.2.2 Processing of Strings by the Program DATATRAN

Strings were transmitted and received with the use of the subroutines OUTSTR and INSTR which were modified, but not written by the author. The strings handled by these routines had to be processed before they were transmitted and after they were received as a result of the different treatments of delimiters employed by the VAX and the oscilloscope in this application.

Prior to transmission of a string by the routine OUTSTR, the CR/LF delimiter used by the VAX computer was removed and replaced by the LF(linefeed) delimiter to be consistent with the

oscilloscope specifications.

After a string was received by the subroutine INSTR (not including the first string), the first character, a LF character, was eliminated before the string was converted. This unwanted LF character appeared for the following reason. Strings sent to the VAX by the oscilloscope were separated by the CR/LF delimiter. The VAX recognized only the CR as a delimiter and treated the LF as a character. (Note that the VAX adds its own LF delimiter.) Thus, a LF appeared as the first character in each string except the first and was removed.

Finally, the author found the use of several run time utility routines to be very helpful in the conversion of data types [2].

REFERENCES

1. Nicolet 4094 Oscilloscope Operation Manual. Nicolet Instrument Corporation, Oscilloscope Division, Madison, Wisconsin. Information concerning data transfer may be found in section 13.
2. VAX 11 Manuals. Digital Equipment Corporation, Maynard Massachusetts, April, 1982. Data conversion utilities are described in the "Run-Time Library Reference Manual" Vol. 6A.

APPENDIX
THE PROGRAM DATATRAN

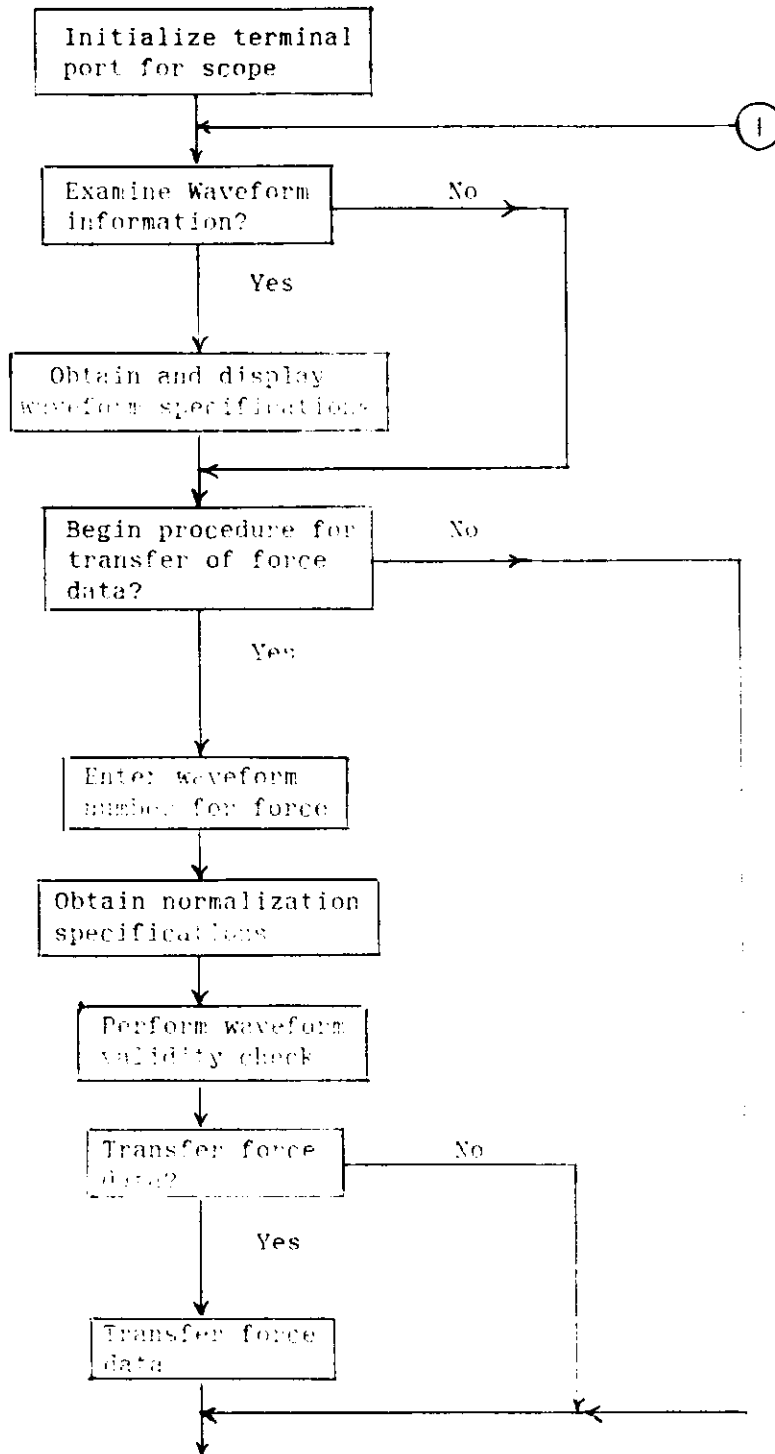

Flow Chart for the program DATATRAN

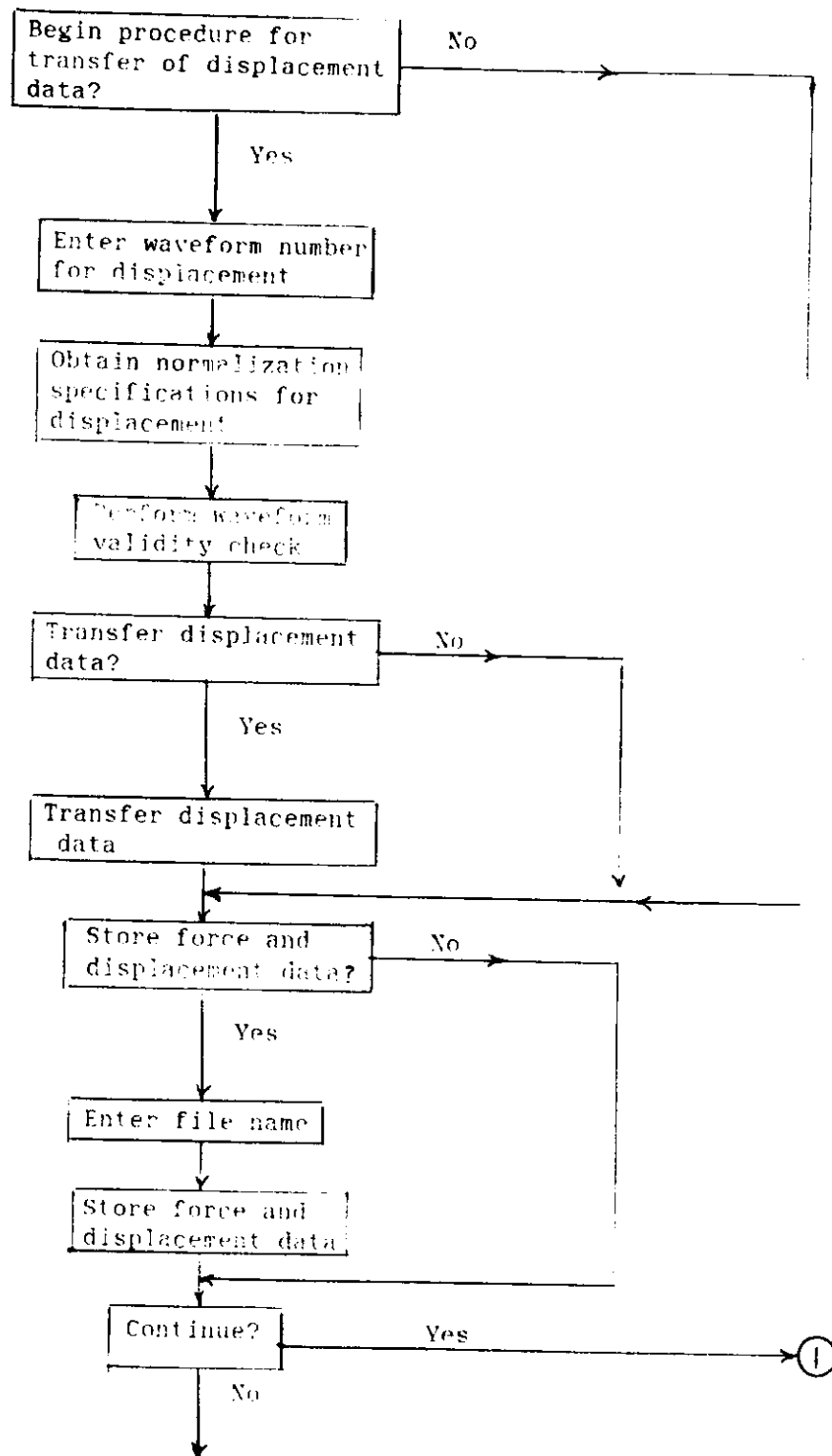

Flow Chart for the program DATATRAN (continued)

```

PROGRAM DATATRAN
CCC
CCC REPORT VERSION
CCC
CCC THIS PROGRAM TRANSFERS DATA FROM A NICOLET 4094 OSCILLOSCOPE
CCC TO A VAX 11/750 COMPUTER. UP TO TWO TRACES MAY BE SELECTED FROM
CCC THE OSCILLOSCOPE MEMORY AND STORED IN A DATA FILE. THESE ARE
CCC DESIGNATED AS THE FORCE AND DISPLACEMENT PROFILES. INFORMATION
CCC CONCERNING THE MEANING OF INPUT AND OUTPUT STRINGS MAY BE OBTAINED
CCC FROM THE NICOLET 4094 OPERATION MANUAL IN CHAPTER 13
CCC

COMMON/A/ICON

CCC
CCC ICON ALLOWS THE FIRST CHARACTER OF THE FIRST STRING RECEIVED FROM
CCC THE OSCILLOSCOPE TO BE RETAINED. THE FIRST CHARACTER (LF) OF
CCC EVERY OTHER RECEIVED STRING IS ELIMINATED
CCC

DIMENSION IW(32,7)
DIMENSION IDF(9000), DF(9000), INF(11), ANF(11), VF(9000)
DIMENSION IDH(9000), DH(9000), INH(11), ANH(11), VH(9000)
CHARACTER LINE*80, SCALL*3, OFNAME*20, DSNAME*20
N=80
SCALL(1:1)=CHAR(1)
SCALL(2:3)='>B'

CCC
CCC INITIALIZATION--SELECT TERMINAL PORT FOR SCOPE CONNECTION
CCC

CALL INIT
ICON=1

CCC
CCC TEST INTERFACE BY SOUNDING BELL ON SCOPE
CCC
70 CALL OUTSTR(SCALL,3)
CALL ERR

CCC
CCC INSTALL DELIMITERS FOR SCOPE OUTPUT
CCC

CALL OUTSTR('C,4,2,13,10',11)
CALL ERR

CCC
CCC OBTAIN WAVEFORM INFORMATION
CCC
101 WRITE(6,102)
102 FORMAT('/' EXAMINE WAVEFORM INFORMATION? 1-YES 0-NO')
ACCEPT*,IANS
IF(IANS.NE.1) GO TO 125

CCC

CALL OUTSTR('W',1)
CALL ERR

CCC

CALL INSTR(LINE,IC)
ISTAT = OTS$CVT_TI_L ( LINE(2:IC), NWT )

```

```

CCC
WRITE(6,105)
105  FORMAT(/' WAVEFORM INFORMATION')
      DO 120 I=1,NWT
        DO 110 J=1,7
          CALL INSTR(LINE,IC)
          ISTAT = OTS$CVT_TI_L ( LINE(2:IC), IW(I,J) )
110    CONTINUE
          WRITE(6,115) (IW(I,J),J=1,7)
115    FORMAT(7I9)
120    CONTINUE
      CALL ERR

CCC
CCC
CCC  OBTAIN FORCE DATA *****
CCC
CCC
125  WRITE(6,126)
126  FORMAT(/' BEGIN PROCEDURE FOR TRANSFER OF FORCE DATA? 1-YES 0-NO')
      ACCEPT*,IANS
      IF(IANS.NE.1) GO TO 225

CCC
      WRITE(5,130)
130  FORMAT(/' ENTER WAVEFORM NUMBER FOR FORCE ')
      READ(5,135) NWF
135  FORMAT(I4)

CCC
CCC  OBTAIN NORMALIZATION INFORMATION FOR FORCE
CCC
      NSETF=IW(NWF,3)
      LINE(1:3)='N,0'
      ISTAT = OTS$CVT_L_TI ( NSETF, LINE(4:4) )
      CALL OUTSTR(LINE,4)
      CALL ERR

CCC
      DO 150 I=1,11
        CALL INSTR(LINE,IC)
        IF(I.EQ.5.OR.I.EQ.6) THEN
          ISTAT= OTS$CVT_T_F ( LINE(2:IC), ANF(I) )
C      WRITE(6,*) ANF(I)
          ELSE
          ISTAT = OTS$CVT_TI_L ( LINE(2:IC), INF(I) )
C      WRITE(6,*) INF(I)
          END IF
150    CONTINUE
      CALL ERR

CCC
CCC  CHECK WAVEFORM VALIDITY
CCC
      IF(INF(1).NE.0) THEN
        WRITE(6,155) INF(1)
155  FORMAT(/' WAVEFORM NOT VALID: NUMBER IS ',I4)
      END IF

```

```

CCC
CCC  TRANSFER FORCE DATA
CCC
      WRITE(6,160)
160  FORMAT(/' TRANSFER FORCE DATA? 1-YES 0-NO')
      ACCEPT*, IANS
      IF(IANS.NE.1) GO TO 225
CCC
      NPTS=IW(NWF,2)
C      NPTS=20
      ISTAT = OTS$CVT_L_TI ( NWF, LINE(5:6) )
      ISTAT = OTS$CVT_L_TI ( NPTS, LINE(10:13) )
      LINE(1:4)='D,0,'
      LINE(7:9)=' ,0,'
      LINE(14:15)=' ,1'
      CALL OUTSTR(LINE,15)
      CALL ERR
CCC
      DO 180 I=1,NPTS
          CALL INSTR(LINE,IC)
          ISTAT = OTS$CVT_TI_L ( LINE(2:IC), IDF(I) )
C          WRITE(6,*) IDF(I)
180  CONTINUE
      CALL ERR
CCC
CCC  SOUND BELL WHEN TRANSFER IS FINISHED
CCC
      CALL OUTSTR('B',1)
      CALL ERR
CCC
CCC
CCC  OBTAIN DISPLACEMENT DATA *****
CCC
CCC
225  WRITE(6,226)
226  FORMAT(/' BEGIN PROCEDURE FOR TRANSFER OF DISPLACEMENT DATA? 1-YES
1 0-NO')
      ACCEPT*, IANS
      IF(IANS.NE.1) GO TO 340
CCC
      WRITE(5,230)
230  FORMAT(/' ENTER WAVEFORM NUMBER FOR DISPLACEMENT')
      READ(5,235) NWH
235  FORMAT(I4)
CCC
CCC  OBTAIN NORMALIZATION INFORMATION
CCC
      NSETH=IW(NWH,3)
      LINE(1:3)='N,0'
      ISTAT = OTS$CVT_L_TI ( NSETH, LINE(4:4) )
      CALL OUTSTR(LINE,4)
      CALL ERR
CCC

```



```

DO 250 I=1,11
  CALL INSTR(LINE,IC)
  IF(I.EQ.5.OR.I.EQ.6) THEN
    ISTAT= OTSS$CVT_T_F ( LINE(2:IC), ANH(I) )
C    WRITE(6,*) ANH(I)
  ELSE
    ISTAT = OTSS$CVT_TI_L ( LINE(2:IC), INH(I) )
C    WRITE(6,*) INH(I)
  END IF
250 CONTINUE
  CALL ERR
CCC
CCC CHECK WAVEFORM VALIDITY
CCC
  IF(INH(1).NE.0) THEN
    WRITE(6,255) INH(1)
255 FORMAT('/ WAVEFORM NOT VALID: NUMBER IS ',I4)
  END IF
CCC
CCC TRANSFER DISPLACEMENT DATA
CCC
  WRITE(6,260)
260 FORMAT('/ TRANSFER DISPLACEMENT DATA? 1-YES 0-NO')
  ACCEPT*,IANS
  IF(IANS.NE.1) GO TO 340
CCC
  NPTS=IW(NWH,2)
C  NPTS=20
  ISTAT = OTSS$CVT_L_TI ( NWH, LINE(5:6) )
  ISTAT = OTSS$CVT_L_TI ( NPTS, LINE(10:13) )
  LINE(1:4)='D,0,'
  LINE(7:9)=' ,0,'
  LINE(14:15)=' ,1'
  CALL OUTSTR(LINE,15)
  CALL ERR
CCC
  DO 280 I=1,NPTS
    CALL INSTR(LINE,IC)
    ISTAT = OTSS$CVT_TI_L ( LINE(2:IC), IDH(I) )
C    WRITE(6,*) IDH(I)
280 CONTINUE
  CALL ERR
CCC
CCC SOUND BELL WHEN TRANSFER IS COMPLETE
CCC
  CALL OUTSTR('B',1)
  CALL ERR
CCC
CCC
CCC STORE DATA AND NORMALIZATION INFORMATION *****
CCC
340 WRITE(6,350)

```

```

350  FORMAT(/' STORE DATA? 1-YES 0-NO')
      ACCEPT*, IANS
      IF(IANS.NE.1) GO TO 405
CCC
      WRITE(6,360)
360  FORMAT(/' ENTER FILENAME')
      ACCEPT'(Q,20A)', LENGTH, DSNAME
      OFNAME=DSNAME(1:LENGTH)//'.DAT'
      OPEN(UNIT=1, FILE=OFNAME, TYPE='NEW')
CCC
      WRITE(1,365) DSNAME
365  FORMAT(3X,A)
      WRITE(1,380) ANF(6)
380  FORMAT(E12.3)
      WRITE(1,370) NPTS
370  FORMAT(I8)
      ANF(7)=DFLOTJ(INF(7))
      ANH(7)=DFLOTJ(INH(7))
CCC
      DO 400 I=1,NPTS
          DF(I)=DFLOTJ(IDF(I))
          VF(I)=(DF(I)-ANF(7))*ANF(5)
          DH(I)=DFLOTJ(IDH(I))
          VH(I)=(DH(I)-ANH(7))*ANH(5)
          WRITE(1,395) VF(I), VH(I)
395  FORMAT(1X,2F6.2)
400  CONTINUE
      CLOSE(UNIT=1)
CCC
CCC  SOUND BELL WHEN FILE IS CREATED
CCC
      CALL OUTSTR('B',1)
      CALL ERR
CCC
405  WRITE(6,410)
410  FORMAT(/' CONTINUE? 1-YES 0-NO')
      ACCEPT*, IANS
      IF(IANS.NE.1) GO TO 999
      GO TO 101
CCC
CCC  EXIT FROM SCOPE
CCC
999  CALL OUTSTR('Q',1)
      CALL ERR
      END

```

```
      SUBROUTINE ERR
CCC
CCC  SUBROUTINE OBTAINS AND EVALUATES THE ERROR CODES FOR TRANSMISSIONS
CCC  BETWEEN THE OSCILLOSCOPE AND THE VAX
CCC
      COMMON/A/ICON
      CHARACTER LINE*80
      N=80
CCC
      CALL INSTR(LINE,IC)
      ISTAT=OTSS$CVT_TI_L ( LINE(ICON:IC), NERR)
      ICON=2
CCC
CCC  CHECK ERROR CODE
CCC
      IF(NERR.EQ.0) GO TO 50
      WRITE(6,30) NERR
30    FORMAT(/' ERROR IS ',I4)
      WRITE(6,40)
40    FORMAT(/' CONTINUE 1-YES 0-NO')
      ACCEPT*,IANS
      IF(IANS.NE.1) THEN
      CALL OUTSTR('Q',1)
      CALL INSTR(LINE,IC)
      END IF
CCC
50    RETURN
      END
```

```
      SUBROUTINE INIT
CCC
CCC  SUBROUTINE OPENS A TERMINAL PORT DESIGNATED BY THE USER FOR
CCC  COMMUNICATION WITH THE OSCILLOSCOPE
CCC

      BYTE INPUT(4)
      CHARACTER*10 TT_NAME
      INTEGER*2 TT_ICHAN,TT_OCHAN,ISTAT,IOSB(4)
      INTEGER*4 SYS$QIOW,SYS$ASSIGN
      DATA INPUT(1) /1H^/
      COMMON/TTIO/TT_ICHAN,ISTAT

      INCLUDE '($IODEF)'

      WRITE (5,1000)
1000  FORMAT (T15' Remember 3 ^C''s to exit program.'//
1      ' Enter terminal to attach to: '$)
      READ (5,2000,END=999) TT_NAME
2000  FORMAT (A)
      ISTAT=SYS$ASSIGN(TT_NAME,TT_ICHAN,..)
      IF (.NOT. ISTAT) CALL LIB$STOP(%VAL(ISTAT))
      GO TO 5000

999   CALL EXIT
5000  RETURN
      END
```

```
      SUBROUTINE OUTSTR(STRING,SIZE)
CCC
CCC  SUBROUTINE SENDS OUTPUT STRING TO OSCILLOSCOPE
CCC
      CHARACTER*(*) STRING
      INTEGER*2 TT_CHAN, ISTAT
      INTEGER*4 SYS$QIOW, SIZE
      CHARACTER*80 LINE

      INCLUDE '($IODEF)'

      COMMON /TTIO/TT_CHAN, ISTAT

      LINE=STRING(1:SIZE)//CHAR(10)
      ISTAT = SYS$QIOW(,%VAL(TT_CHAN),
1          %VAL( IOS_ WRITEVBLK+IOSM_NOFORMAT),...,
2          %REF(LINE),%VAL(SIZE+1),...,)
      IF(.NOT. ISTAT) CALL LIB$STOP(%VAL(ISTAT))

      RETURN
      END
```

```

SUBROUTINE INSTR(LINE,IC)
CCC
CCC SUBROUTINE RECEIVES STRING SENT BY OSCILLOSCOPE
CCC
CHARACTER LINE*(*)
N=80
IC=INECHO(LINE,N)
RETURN
END
CCC

INTEGER*2 FUNCTION INECHO(STRING,SIZE)

CHARACTER*(*) STRING

INTEGER*4 SYS$QIOW,SIZE
INTEGER*2 IOSB(4),TT_CHAN,ISTAT

COMMON /TTIO/ TT_CHAN,ISTAT

INCLUDE '($IODEF)'

ISTAT = SYS$QIOW(,
1          %VAL(TT_CHAN),
2          %VAL(IO$_READVBLK+IO$_NOECHO),
3          %REF(IOSB),
4          ,
5          ,
1          %REF(STRING),
2          %VAL(SIZE),
3          ,
4          ,
5          ,
6          )

IF(.NOT. ISTAT) CALL LIB$STOP(%VAL(ISTAT))

INECHO = IOSB(2)      !RETURN THE NUMBER OF CHARACTERS READ
RETURN
END

```

APPENDIX C
BISON INSTRUMENT MANUAL

INSTRUCTION MANUAL

BISON INSTRUMENTS
SOIL STRAIN GAGE
MODEL 4101A



INSTRUCTION MANUAL
BISON SOIL STRAIN GAGE MODEL 4101A

Outline

	<u>Page</u>
I. Introduction	1
II. Instrument Description	4
A. General Features	4
B. Basic Components	6
C. Specifications	8
III. Explanation of Control Functions	12
A. Rear Panel	12
B. Front Panel	14
IV. Preliminary Steps and System Check Out	18
V. Calibration Characteristics	25
VI. Calibration Procedures	38
A. Spacing Calibration	38
B. Meter Calibration	42
C. Dial Calibration	48
D. Rapid Calibration	51
VII. Sensor Installation	58
VIII. Sensor Configuration and Alignment Effects	61
A. Multiple Channel Use	61
B. Offset and Rotation Effects	62
C. Possible Configurations	65
IX. Application	71

I. INTRODUCTION

One of the major factors limiting the engineer's ability to efficiently design earth structures is the insufficiency of measurements telling him what is going on inside the soil mass. Such measurements include settlement and deflection, pore pressure, total stress and strain. Of all of these, strain has received the least attention and until recently only a few attempts to measure strain in soil have been reported.¹ The single, most important omission in our knowledge of soil behavior is strain since from many points of view strain is one of the most useful and relevant measurements that could be made. Strain is certainly as fundamental a measure of soil response as any, including stress, and a knowledge of strain could hold the key to understanding and solving many soil mechanics problems. Three examples to follow will serve to illustrate this point.

Finite element analysis is a new analytical tool which has promise for solving soil mechanics problems because it can represent soil as the much more complex material it is than previous methods. However, this capability has created a new difficulty--how to determine the correct constitutive relationships (stress-strain-time behavior) of the soil for the engineering problems being analyzed. In situ measurement of strain in connection with these problems will be essential if knowledge about the true nature of the behavior of soil is going to be obtained.

¹Selig, E.T., "A Review of Stress and Strain Measurement in Soil," Proceedings of the Symposium on Soil-Structure Interaction, University of Arizona, Tucson, Arizona, pp. 172-186, Sept. 1964.

Compaction is a process of densifying soil which really means decreasing its volume. Volumetric strain is obviously a direct measure of this process. Many questions about compaction remain unanswered because they require remote and continuous monitoring of the associated volume changes. Among these questions are 1) how far below the surface is compaction taking place, 2) how much subsequent volume change occurs due to consolidation and moisture and temperature variation, 3) what is the effect of vibration on compaction, and 4) what changes occur in lower layers when upper layers are added. The simplest and most direct approach available for studying these questions is by means of embedded strain gages.

Both pavement and buried structure response represent forms of soil-structure interaction. Rigorous design procedures require knowledge of the soil deformation characteristics under load. These can not be determined by stress measurements alone. In the case of pavements the ability to make reasonable estimates of stress distribution due to traffic loads has been demonstrated, but estimates of the strains causing the deflection are not possible without extensive testing of the soil properties. In the case of buried structures it can be argued with confidence that the arching or stress redistribution is a direct result of the differential strains caused by a difference in modulus between the soil and the structure. The measurement of strains in both of these interaction situations is certain to improve the understanding of the phenomena taking place as well as aid in determining the proper moduli to use in analysis.

The strains being considered may be defined as changes in spacing (extension or compression) between two reference points in the soil divided by the spacing (gage length). To accomplish this a method is desired which can measure these changes without restricting the soil movement and which permits satisfactory placement (installation) of the sensor. The Bison 4101A instrument provides a new and unique technique for this purpose.

II. INSTRUMENT DESCRIPTION

A. General Features

The strain gage system consists of two basic components: 1) a pair of embedded sensors, and 2) an external instrument package.

The sensors, each of which is a disk-shaped coil, are placed in the soil in near parallel and coaxial alignment. They are separated a distance over which the strain is to be averaged. Pairs of sensors 1-, 2- and 4-in. in diameter are shown in Figure 2-1. These are the standard sizes currently being manufactured. However, for special applications other sizes can be provided. The separation of the sensors is related to the electro-magnetic coupling between the two. By means of an inductance bridge an output voltage as a function of strain may be obtained since a change in spacing from the initial spacing produces a bridge unbalance. A unique feature is that the sensors are free-floating in the soil to provide minimal interference with the soil movement. They can operate at any spacing between 1 and 4 times the nominal sensor diameter; however, the minimum spacing can be made to approach zero by a relatively simple electrical modification. The effects of rotational or transverse movement and moisture and temperature usually are negligible, and the effect of different cable lengths can easily be accounted for during calibration.

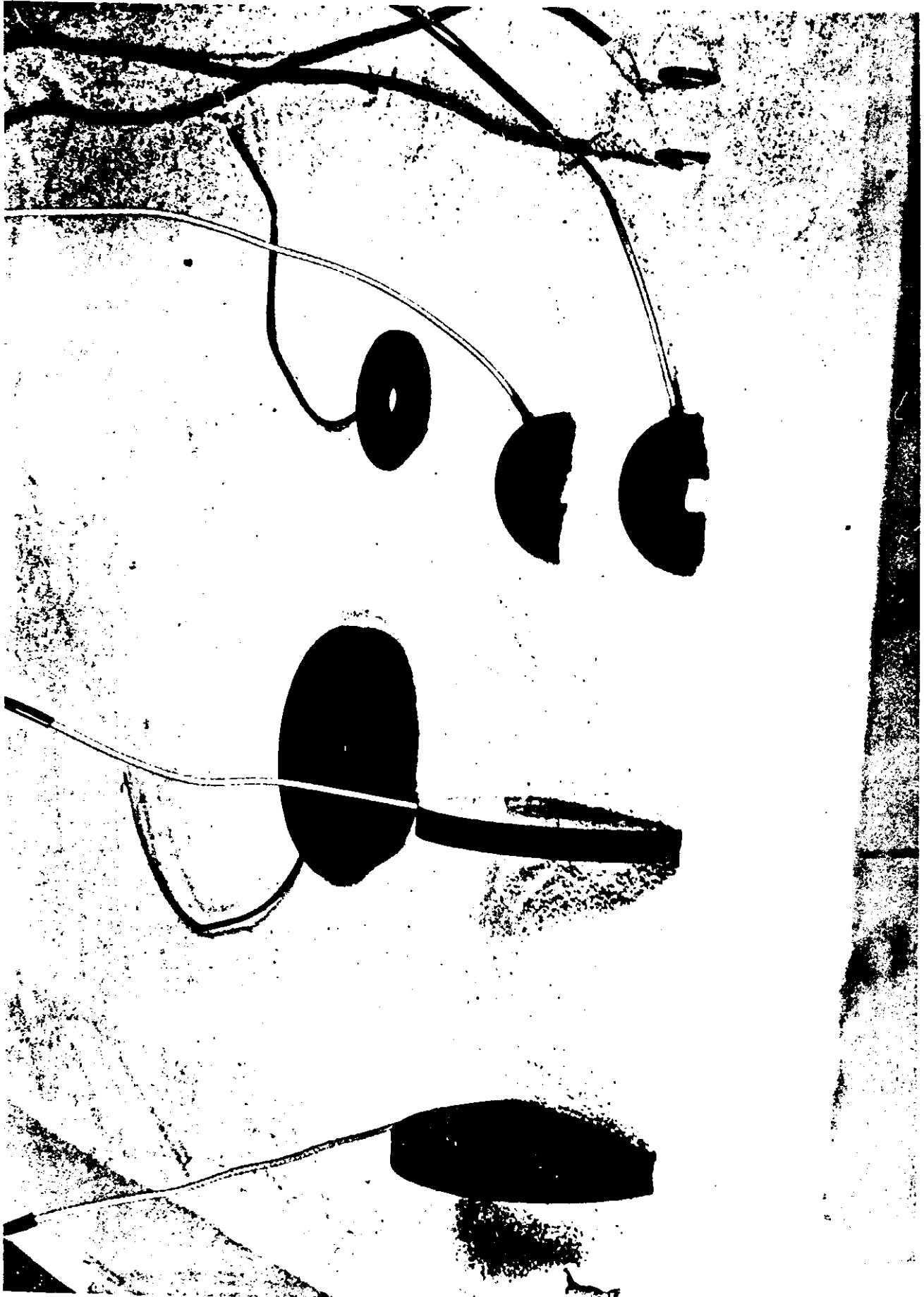

Figure 2-1. One-, Two- and Four-inch Diameter Sensors

The external instrument package to which the sensors are connected contains all necessary driving, amplification, balancing, read out and calibration controls and a self-contained power supply (Figure 2-2). The bridge balance is accomplished by means of the phase and amplitude controls using the meter to indicate null. The amplitude dial reading corresponds to the sensor spacing. Changes in spacing may be determined by renulling and noting the changes in the amplitude reading. They may also be determined by meter deflection from zero or by voltage output on a recorder connected to the rear panel. When these latter methods are selected the calibration control is used to set up the output sensitivity so that it corresponds to a desired amount of strain. Because the instrument is battery operated it is completely portable which is a convenience both in the laboratory and in the field. This particular instrument was designed for dynamic strain and it has the ability to sense changes as fast as about 0.25 msec.

B. Basic Components

The complete list of equipment generally used with the Model 4101A, excluding tools for soil placement is as follows:

1. Instrument - Model 4101A.
2. Sensors, either 1-, 2- or 4-in. diameter with cables.
3. Calibration fixture.
4. Standard reference sensor.
5. Battery charger with connecting cable*.
6. Instruction manual*.

*Supplied with the instrument.

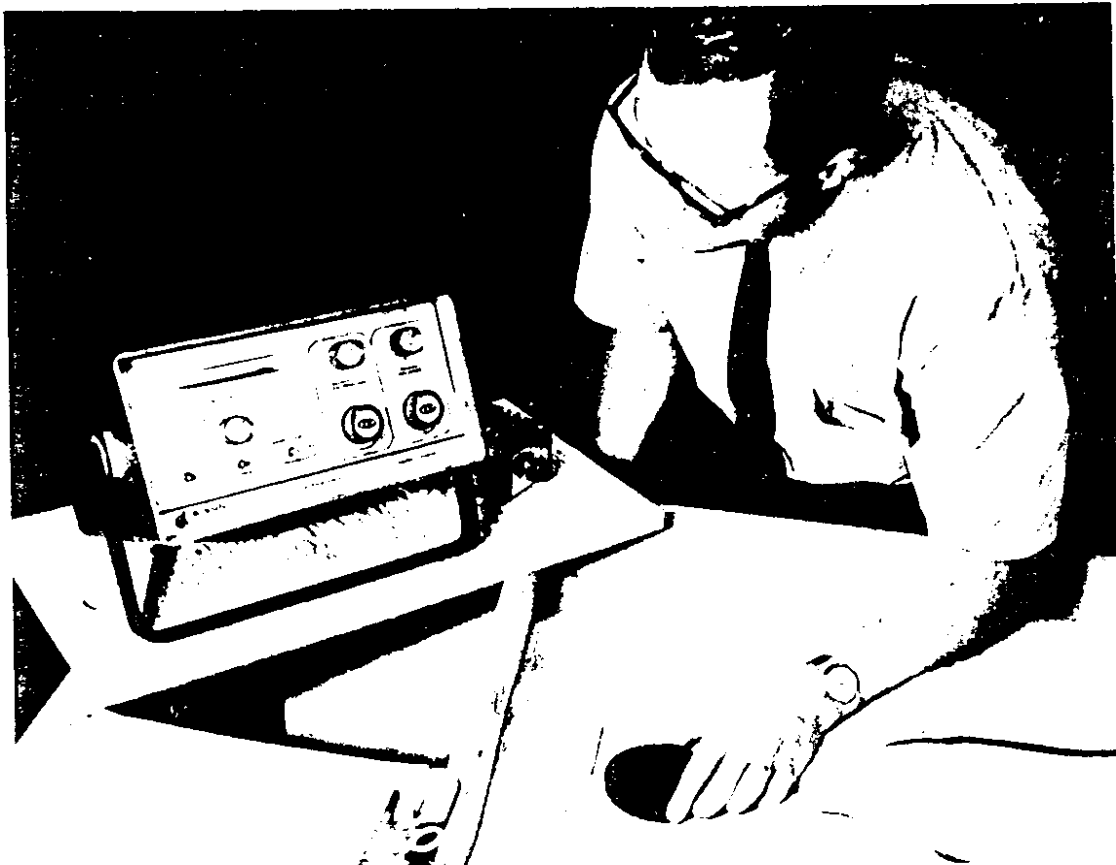
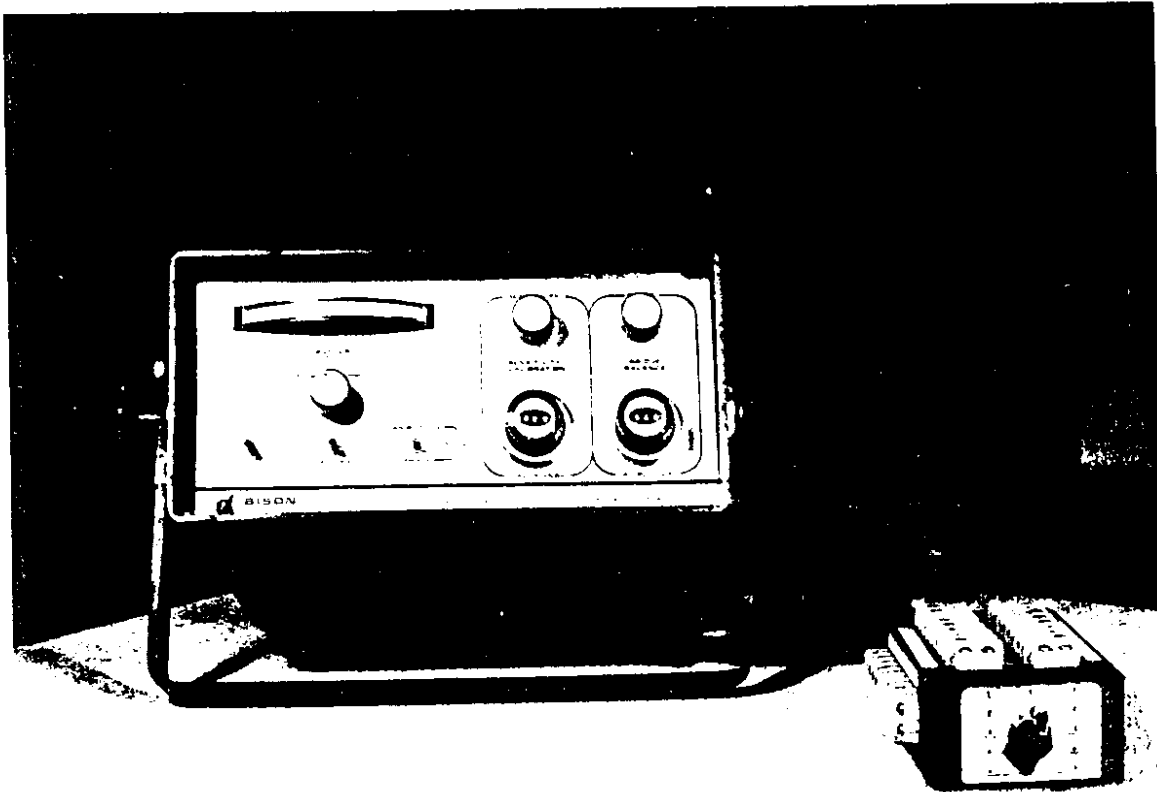

Figure 2-2. Dynamic Strain Gage Instrument

C. Specifications

1. Sensor size:

The three standard sizes available for immediate delivery are:

1-1/8-in. diameter by 1/8-in. thick.

2-1/8-in. diameter by 1/4-in. thick.

4-1/8-in. diameter by 1/4-in. thick.

Sensor bodies are machined linen phenolic base forms with coils potted in epoxy for environmental stability. Other size sensors are available on special order.

2. Excitation Characteristics:

Frequency = 20 khz.

Amplitude = 15 volts peak-to-peak.

Total harmonic distortion = 0.3% .

Short term frequency stability is $\pm 0.1\%$ (1 hour period under any load). Provision is provided for external oscillator.

Input impedance is greater than 2 kohms.

3. Response Time:

For step input, 0.25 msec. with 2% maximum overshoot and no ringing. Low frequency response is d.c. with good long term stability.

4. Output Voltage:

Output of ± 5 volts will correspond to full scale meter deflection. Output continues linear to ± 10 volts for recorders. Output impedance to recorder is 50 ohm and output is short circuit proof.

5. Maximum Sensitivity:

0.1 percent strain per volt,
or, based on 1-in. sensor, in terms of spacing change is
0.00012 in. movement per volt, or
0.0004 in. movement per AMPLITUDE dial division.

6. Resolution:

Infinite on recorder output.
Limited to 0.01 per cent strain on the meter and to 0.04 per cent strain on the AMPLITUDE dial.

7. Temperature:

Operating temperature is 0°C to 70°C ambient.
Temperature error on electronics is 10 μV per 1°C at maximum sensitivity.

Storage temperature is -55°C to $+85^{\circ}\text{C}$ ambient.

8. Signal to noise ratio:

50 to 1.

9. Cable Lengths:

Cables normally should be 0 to 1000 ft long, but can be longer if desired. Output and strain measurements are independent of changes in cable length and cable characteristics due to temperature, time, pressure and moisture.

10. Power Supply:

Self-contained rechargeable ± 12 volt 1.2 AH battery pack operation. External 110/220 volt -50/60 hz charger. Instrument may be operated continuously with the charger cord plugged into bench supply. Charging rate is 0.12 amps.

11. Circuitry:

Integrated circuits together with individual silicon semiconductors securely mounted on 5 plug-in glass epoxy circuit boards.

12. Readouts:

Panel mounted meter -100 to 0 to + 100 scale. Digital readouts 0 to 10,000.

13. Case:

Bison designed high impact ABS case, weatherproof and operable in any position.

14. Dimensions:

10" x 6.5" x 12".

15. Weight:

Operating weight = 10 lb.

Shipping weight = 13 lb.

III. EXPLANATION OF CONTROL FUNCTIONS

A. Rear Panel (Figure 3-1)

COIL SEPARATION (DIAMETERS) This is the coarse amplitude null control and is set according to the spacing of the embedded sensors.

Range 1 covers nominal separations of from 1 to 2 diameters.

Range 2 covers nominal separations of from 1.5 to 3 diameters.

Range 3 covers nominal separations of from 2.5 to 4.5 diameters.

ZERO This is the DC output (record output and meter) offset control and is set to provide a zero level output signal under normal operating conditions with no input signal.

EXT. OSC. These two connectors are tied together to provide a loop through capability whenever more than one instrument is connected to an external, sinusoidal, source of excitation. The apparent impedance to ground as seen at the connector is 10,000 ohms resistive.

OSC. SELECT This switch is normally set to the INT. (internal) position, but should be switched to the EXT. (external) position whenever an external source is connected to the EXT. OSC. connector input.

OSC. OUTPUTS These two connectors are tied together and to the power amplifier. This is the source of transducer excitation. Either one may be connected to the driven coil in an embedded sensor set and/or to the EXT. OSC. input connector of other units. One is also connected to the driven coil in the reference set of sensors when they are used.

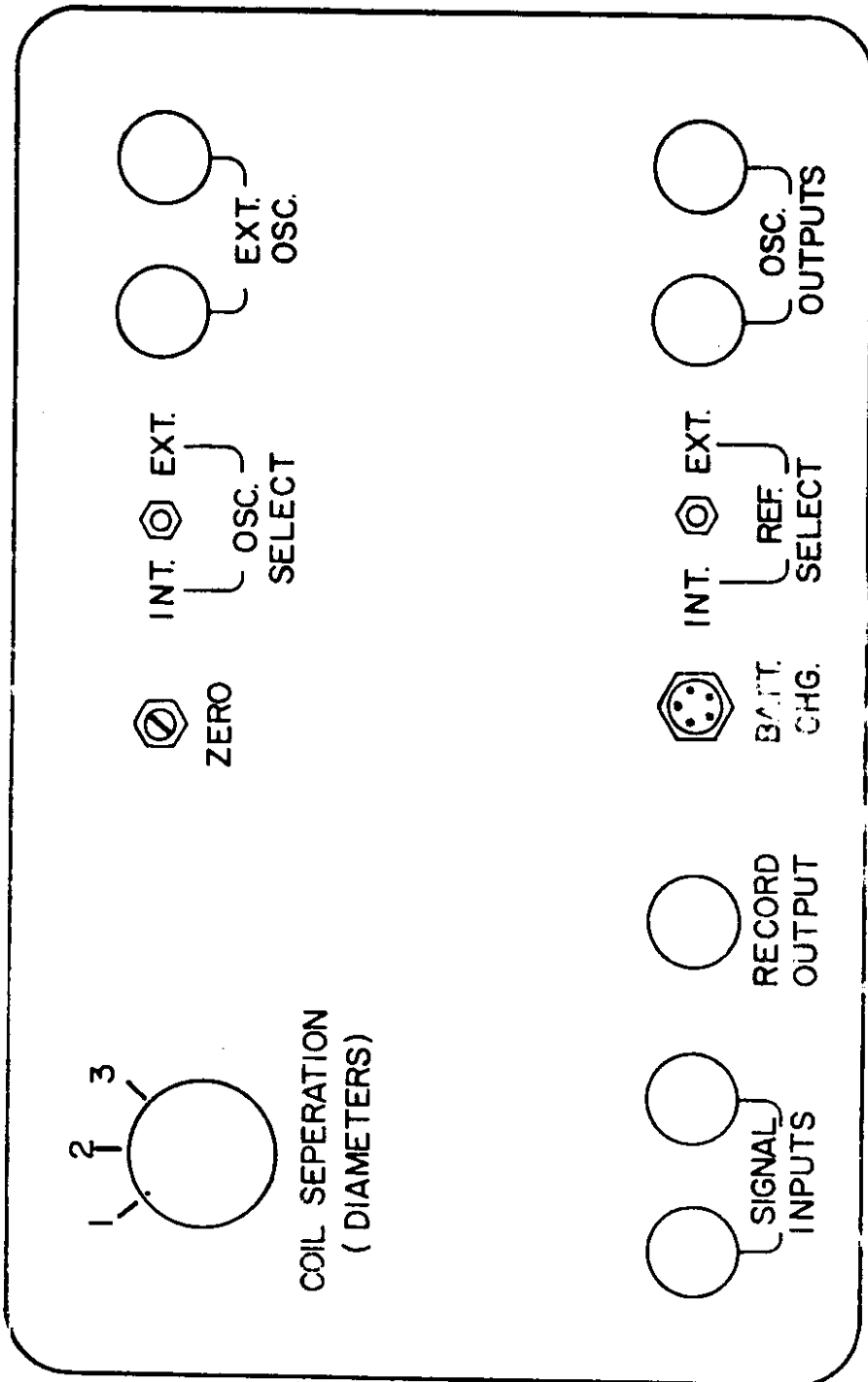

Figure 3-1. Rear Panel

SIGNAL INPUTS These two connectors are tied together. Either one may be used to receive the output signal from the embedded sensor set. The other is for the output signal from the reference set of sensors when they are used. The apparent impedance to ground as seen at the connectors is virtually zero, as it is the signal current and not voltage that is being measured by the device.

RECORD OUTPUT This connector provides an output signal voltage to external monitoring devices. The output impedance is set at 50 ohms resistive and the instrument is not damaged by sustained short circuits.

BATT. CHG. This connector is provided for the attachment of a battery charger. The charger will operate when connected regardless of the other instrument settings. The instrument will operate continuously with the battery charger attached.

REF. SEL. This switch is normally set to INT. (internal) position, but must be switched to the EXT. (external) whenever both an external reference sensor and an embedded sensor are connected to the SIGNAL INPUTS connectors.

B. Front Panel (Figure 3-2)

OFF, BATTERY TEST, ON This is the power switch. When in the OFF mode the unit is inoperative. When in the BATTERY TEST mode the meter should indicate in the green. The ON position is used when measurements are being made with the sensors.

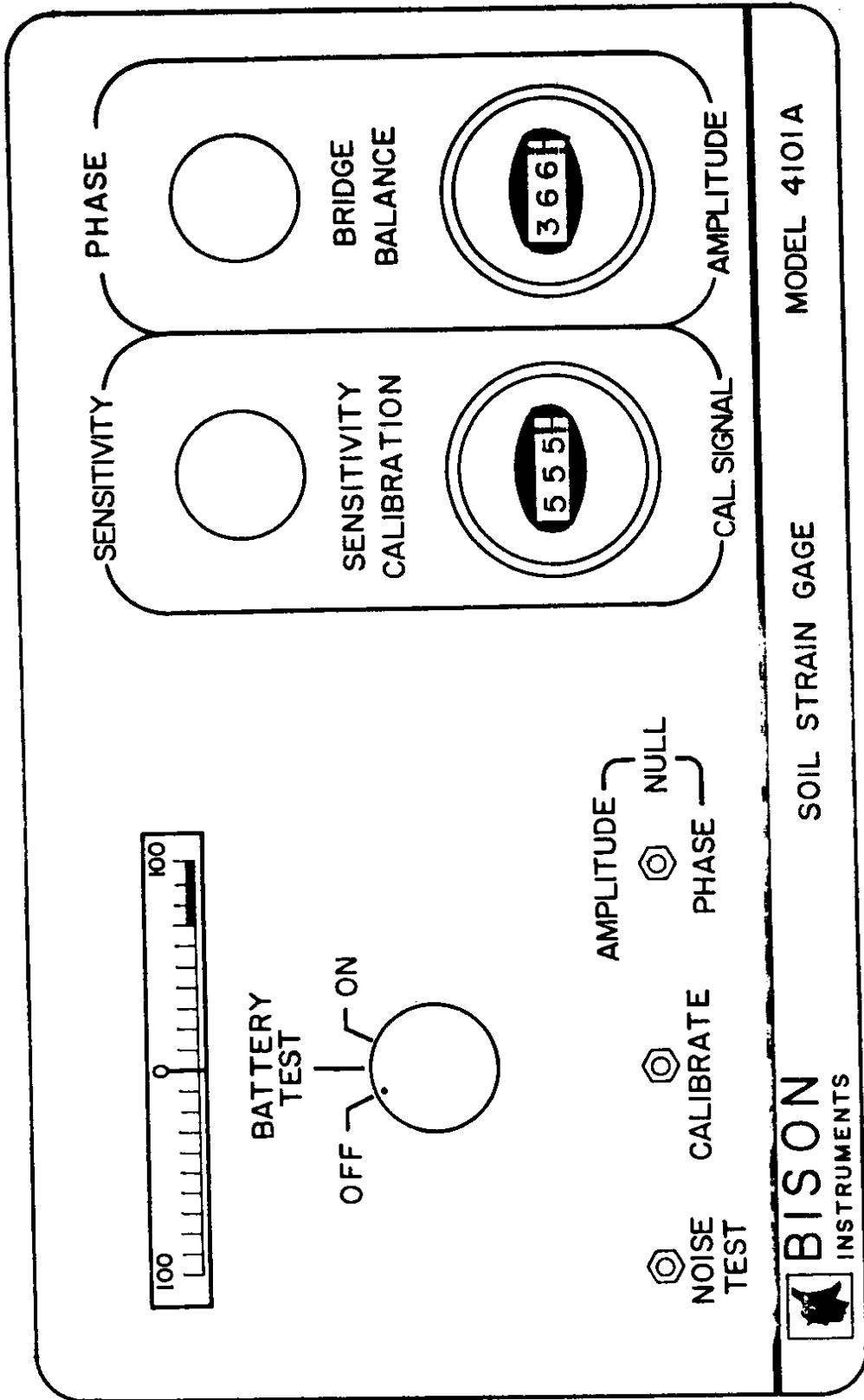

Figure 3-2. Front Panel

AMPLITUDE-PHASE (NULL) When depressed to the PHASE position, this switch allows the meter and/or RECORD OUTPUT to indicate the unwanted quadrature signal component so that a phase balance can be established. When in the AMPLITUDE position, the meter and RECORD OUTPUT respond to the desired in-phase signal and can be used to establish amplitude balance. The AMPLITUDE position is the normal position. The switch returns to this position when it is released.

SENSITIVITY This control establishes the sensitivity to soil strain by changing the instrument gain. Sensitivity increases with clockwise rotation.

CALIBRATE This switch operates in conjunction with the calibrate pot and when depressed introduces a signal that simulates a change in spacing of the embedded sensor. When this switch is released, it automatically returns to the measurement position.

CAL. SIGNAL This together with the CALIBRATE switch allows the operator to simulate a change in sensor spacing so that a desired sensitivity can be obtained. Its dial is used in conjunction with established calibration curves, or to precisely reset sensitivity.

PHASE (BRIDGE BALANCE) This control introduces a signal to balance out the unwanted quadrature signal component. It is operative only when the REF. SEL. switch on the rear panel is in the INT. position.

AMPLITUDE (BRIDGE BALANCE)

This control introduces a signal to balance out the desired in-phase signal component. Its dial reading is directly related to embedded sensor spacing. Increasing values correspond to increased spacing for a given range setting (COIL SEPARATION setting on rear panel). This control is operative only when the REF. SEL. switch on the rear panel is in the INT. position.

NOISE

The relative signal component due to extraneous noise is indicated when this switch is depressed. This function determines if and when the extraneous noise is of a level to preclude accurate strain readings. Noise level indications of less than full scale meter deflection are allowable.

IV. PRELIMINARY STEPS AND SYSTEM CHECK OUT

The following steps should be followed in preparing for making measurements with the Model 4101A soil strain gage:

1. Battery Check

Rotate power switch to BATTERY TEST position. For satisfactory results the meter should read in the green. If it does not, the battery must be recharged before use.

2. Zero Check

Rotate power switch to ON. With all cables disconnected, switch REF. SEL. switch on back panel to EXT. The OSC. SELECT switch should be on INT. Turn SENSITIVITY control to minimum (counterclockwise to limit of movement). Adjust meter to zero, if necessary, by rotating the ZERO ADJUST screw on rear panel. Lock screw. When the zero adjustment is correct, the meter will not deflect from a null position as the SENSITIVITY control is changed after balancing. (Step 7).

3. Oscillator Mode

If the internal oscillator is to be used set rear panel OSC. SEL. switch to INT. If not, set switch to EXT. and connect a 20 khz, 15 volt peak-peak external signal to one of the EXT. OSC. input terminals.

4. Reference Sensor Mode

The normal operating mode for this instrument used the internal simulator to balance against a pair of embedded sensors. If this mode is to be used set the REF. SEL. switch to INT. and follow Steps 5

through 10 below. If an external pair of sensors are to be used for balancing, set REF. SEL. to EXT. and follow Steps 11 through 13.

5. Connect Sensors

Set up a pair of sensors on the calibration fixture (Figure 4-1). Attach one sensor to one of the OSC. OUT. connectors and one to one of the SIGNAL INPUT connectors. If both sensors are identical, either one can be used in either position.

6. Mounting

Set the SENSITIVITY control to its mid-scale value (5 turns clockwise). Rotate power switch to ON with the AMPLITUDE dial in the middle of its range (around 500), hold sensors at a spacing within the range for the COIL SEPARATION setting on the rear panel. Move sensors apart and together to determine if the meter passes through null. (If the sensors are marked on one face, the proper orientation should be for the marked faces of each pair to be in the same direction along their common axis). If not, reverse one sensor relative to the other. The side facing away from second sensor should now face toward second sensor. Meter should then pass through null as sensor spacing is changed. Mount on calibration fixture with this final orientation. Be sure COIL SEPARATION setting roughly corresponds to spacing of sensors on calibration fixture.

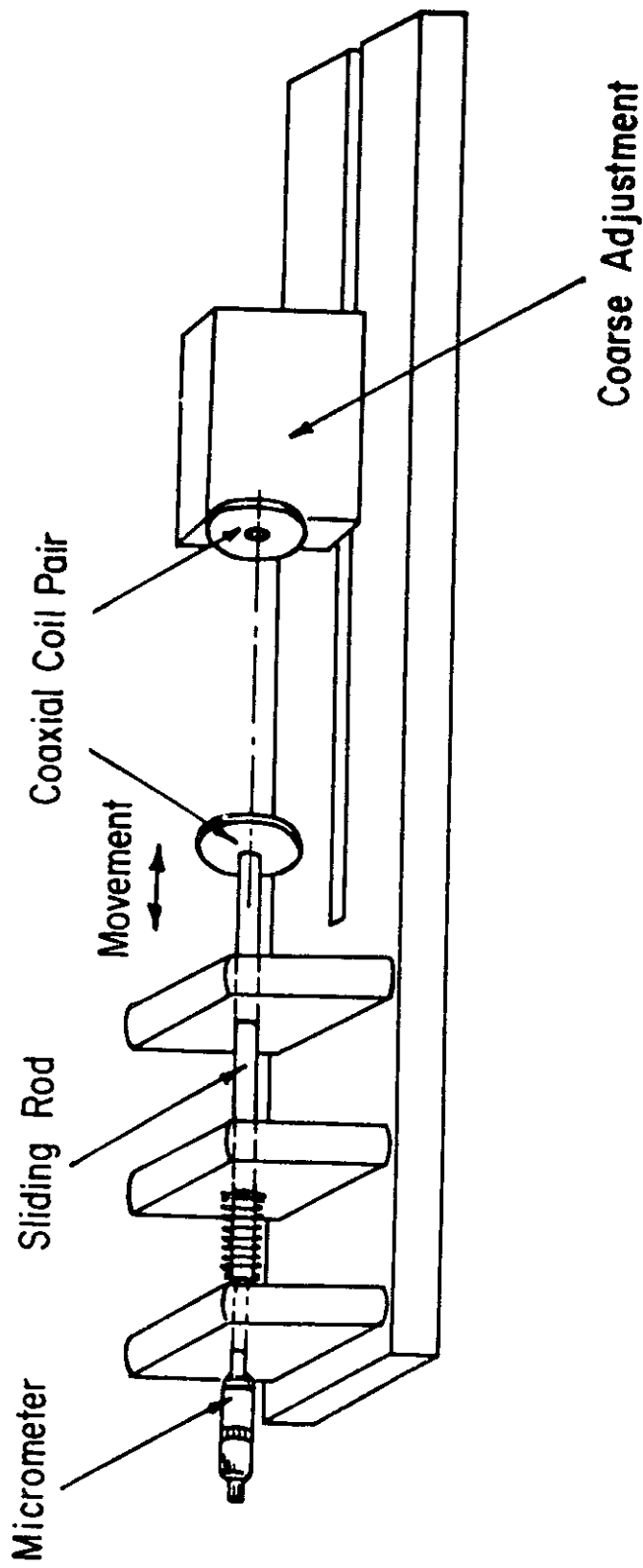

Figure 4-1. Calibration Fixture for Sensors

7. Balancing Procedure

Set the SENSITIVITY control to a low level (1 or 2 turns clockwise from limit of travel). Adjust AMPLITUDE control to null meter (meter reads zero). If this can not be done within limits of the dial compare sensor spacing with COIL SEPARATION setting. If these do not correspond, correct one or the other. If amplitude still can not be balanced, depress PHASE switch and adjust PHASE control to null meter. Release switch and null amplitude. Check phase balance again and adjust control to null, if necessary. Continue until both phase and amplitude are balanced (nulled). Then increase sensitivity in steps until either the desired or the maximum sensitivity is reached, each time repeating the phase and amplitude balancing procedure.

With practice, the phase and amplitude balance can be obtained without starting at low sensitivities. Experience shows that this can be done most easily by alternating between PHASE and AMPLITUDE just partially nulling meter each time until finally complete null is achieved. Complete nulling of each in one step at high sensitivities results in over correction.

8. System Check

With phase and amplitude in null, note AMPLITUDE dial reading. From a calibration curve like that in Fig. 5-1, determine sensor spacing (center to center distance). If system is performing properly, this should correspond to actual spacing. Depress and hold noise switch. Deflection of meter indicates magnitude of internal noise present. Very little meter movement (less than 5 divisions) should be observed. If full scale deflection is exceeded, the source of the extraneous noise should be identified and corrected. A reduction in sensitivity

may be required to obtain satisfactory noise levels.

9. Calibration Check

Set CAL SIGNAL dial at 1000. Check phase and amplitude balance, adjusting if necessary. Adjust sensitivity so that meter deflects full scale (100 to the left of null position) when CALIBRATE switch is depressed. Release CALIBRATE switch. Move micrometer to increase sensor spacing so that meter moves 80% full scale to the left. Record initial and final micrometer readings and compute change in spacing of sensors. This change divided by initial center to center spacing of sensors (gage length) should correspond to 0.8 times the calibration strain indicated on the calibration chart, like that in Figure 5-5.

10. Standard Sensor Check

An alternate procedure to Steps 8 and 9 for obtaining a system check is to use the standard sensor set. This sensor set is extremely stable and will not change spacing due to changes in ambient temperature and moisture. Attach one cable from the standard sensor to the OSC. OUT. connector and one cable to the SIGNAL INPUT connector. Set the COIL SEPARATION switch to its proper position and obtain a balance with the PHASE and AMPLITUDE controls. Note AMPLITUDE dial reading. It should approximately correspond to nominal value given on sensor (exact value will vary with each instrument). During subsequent testing this actual AMPLITUDE reading will provide a basis for determining changes in the instrumentation or the presence of environmental effects.

11. Set up External Reference

When external reference sensors are used to balance the embedded sensors, the system may be checked by mounting the two sets of sensors at approximately the same spacing on two calibration fixtures or one set on a fixture and the other on a non-conductor spacer block.

Note: The two sensor sets should be physically separated by at least ten sensor diameters to minimize interaction between the magnetic fields of the sensor sets. Connect one cable from each set to OSC. OUT. and the other cables to SIGNAL INPUTS. With one of the pair of sensors stationary, move the other pair apart and together to see if the meter goes through null. If not, reverse the orientation of one of the sensors. If the sensors are marked on one face, the proper orientation should be for the marked faces of one pair to be in the same direction along their common axis, and the marked faces of the other pair to be either both toward each other or away from each other. Normally, the reference pair should have this latter orientation.

12. Balancing Procedure

Insert a ganged variable resistor in series with the input leads on each sensor of the reference pair. A potentiometer range of zero to 100 ohm will probably be adequate. Set both pair of sensors at the same spacing and balance the phase by depressing the PHASE switch and adjusting the series potentiometers to bring the meter to null. Release the PHASE switch. If meter is not nulled, adjust the spacing of the reference sensors with the micrometer. Recheck phase null and repeat the process until both phase and amplitude are nulled.

13. System Check

The system may be checked by separating the sensors at various distances and comparing the spacing of the two pairs at null balance. They should be approximately the same at any spacing selected.

V. CALIBRATION CHARACTERISTICS

To calibrate the sensor a fixture (Figure 4-1) is used on which the sensors can be mounted and displaced axially with a 0.0001-in. micrometer. Although there are some deviations from instrument to instrument and from sensor to sensor, the relationships presented are representative of the system characteristics.

The unique relationship between the null balance AMPLITUDE dial reading and the 2-in. diameter sensor spacing (center-to-center distance) is shown in Figure 5-1. Note the overlap between the three coarse balance ranges. This shows that the sensors can be balanced anywhere from the minimum position of range 1 to the maximum position of range 3. For large differential sensor movements these curves may be used to determine strain by subtracting the initial and final spacings represented by the corresponding AMPLITUDE dial readings.

Figure 5-1 shows that the inductance coupling of the sensors is basically nonlinear since a change in amplitude balance is directly proportional to a change in output voltage of the bridge circuit. The greater the sensor spacing in a given range, the smaller the change in voltage per unit change in spacing.

For small differential movements or where a recorder is to be used the instrument is balanced initially (Figure 5-1 will give the corresponding initial spacing) and the voltage produced by a subsequent change in spacing is detected either on the meter or on the attached recorder. The

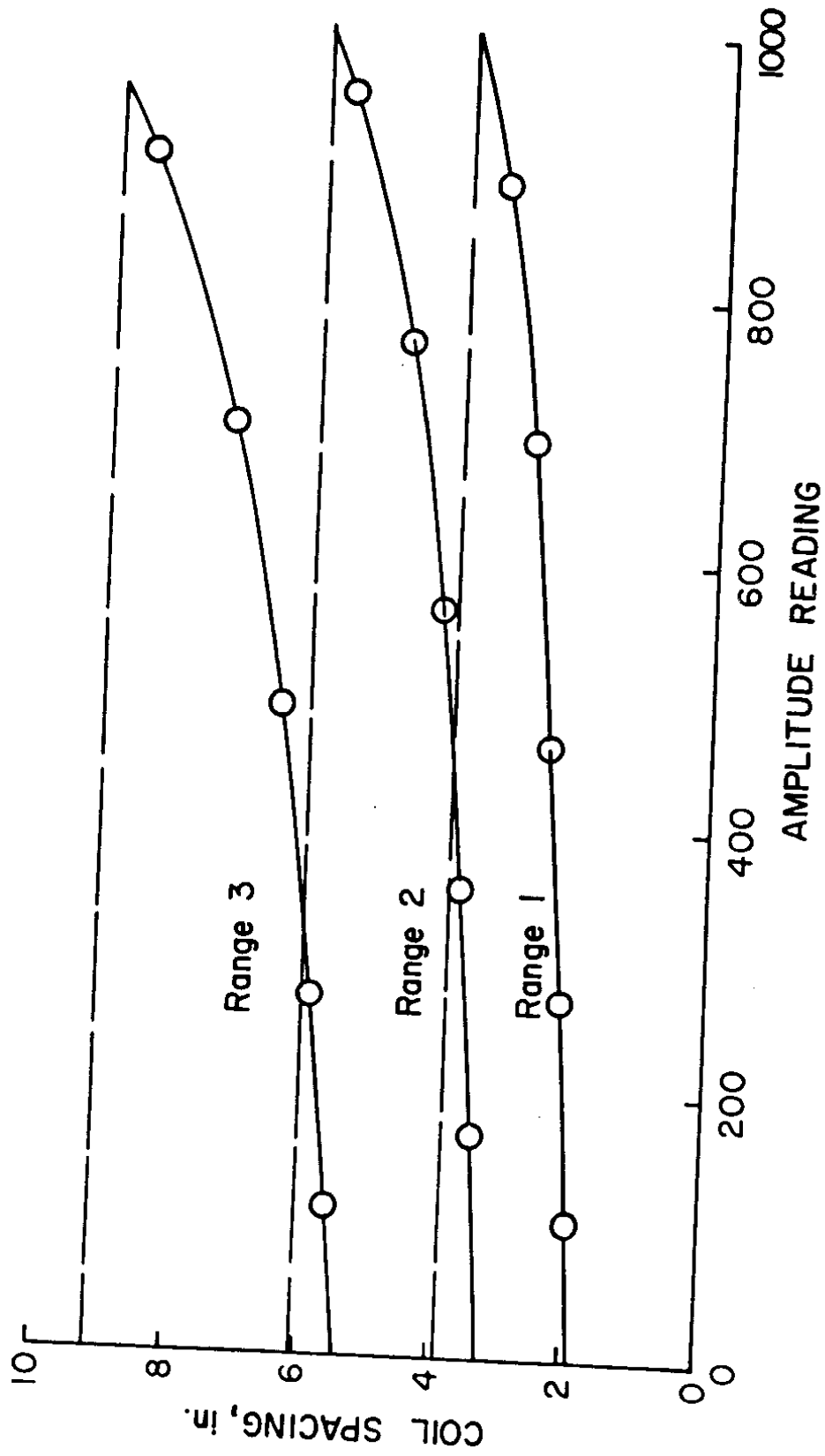

Figure 5-1. Sensor Spacing Calibration Curves for Dynamic Instrument

output voltage is basically a nonlinear function of strain (percent change in spacing); therefore, the error which would be created if a linear relationship is assumed depends upon the magnitude of strain. In addition, since the sensitivity of the instrument decreases with increasing initial spacing the calibration factor will vary with spacing. These nonlinearities may be readily accommodated in the data reduction process to any degree of accuracy desired. Thus they do not represent a significant limitation in the use of this technique.

Examples of meter deflection (full scale represents a recorder output of about 5 volts) versus differential sensor displacement are shown in Figure 5-2, 5-3, and 5-4 covering a range from small to large strains. The strain required to produce full scale deflection in extension is equal to or greater than that required in compression. Thus the meter or voltage calibration curves are different for extension and compression strains. If the meter calibration is defined as the strain required to obtain full scale deflection, then the maximum error due to the nonlinearity will occur at about 50% of full scale. Based on the data of the type given in Figures 5-2, 5-3 and 5-4 this error will be less than 10% of full scale strain if these strains are less than 12% in extension and less than 4% in compression. The errors will be minimized with a linear assumption if the meter calibration is based on a meter deflection between half and full scale (approximately 80% rather than 100% full scale) such that the maximum positive error is equal to the maximum negative error.

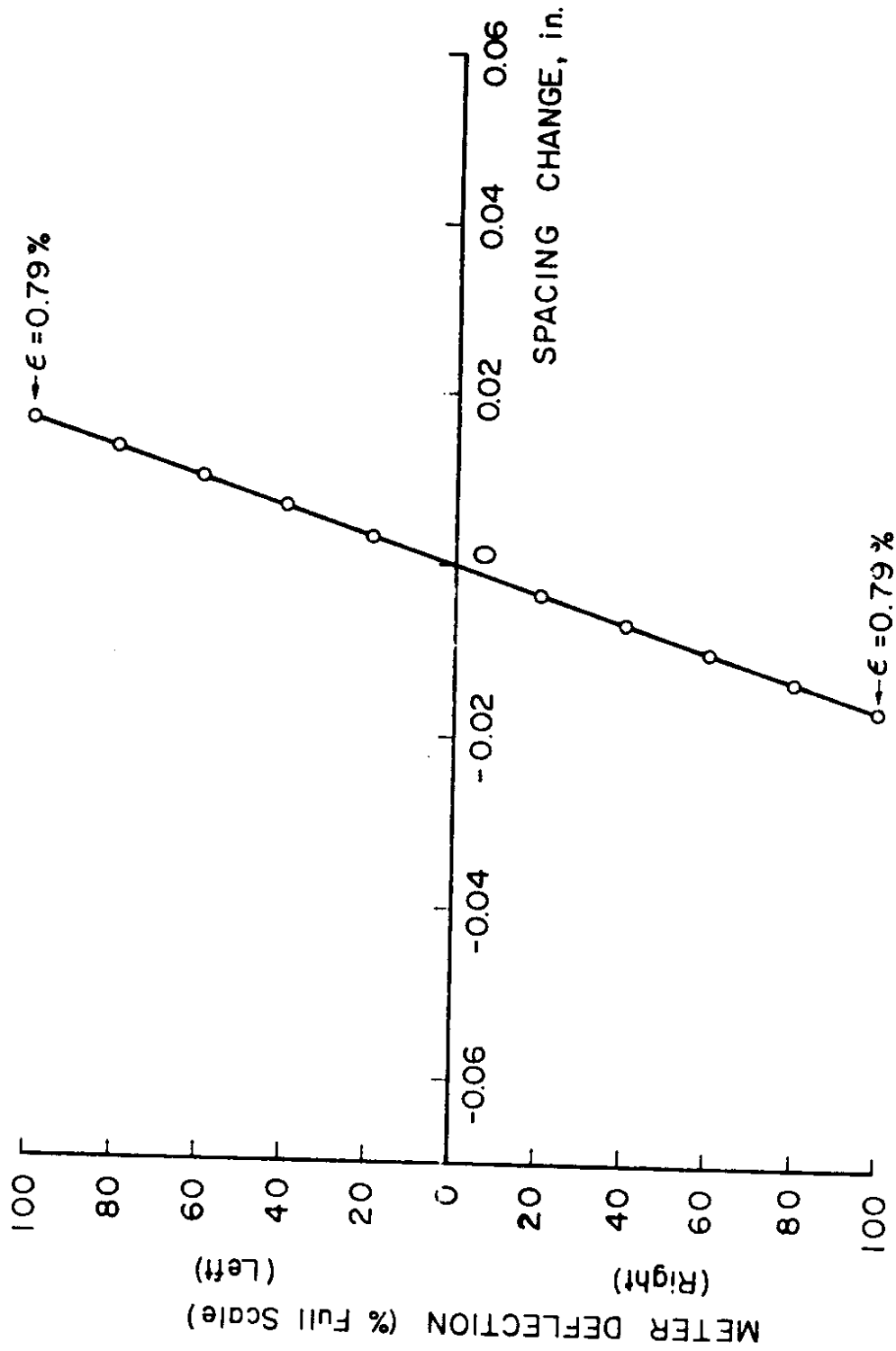

Figure 5-2. Meter Deflection in Response to Spacing Change (Range = 1, Amp Dial = 200, Initial Spacing = 2.06 in., Standard Sensitivity, Sensors = 2-in. diam)

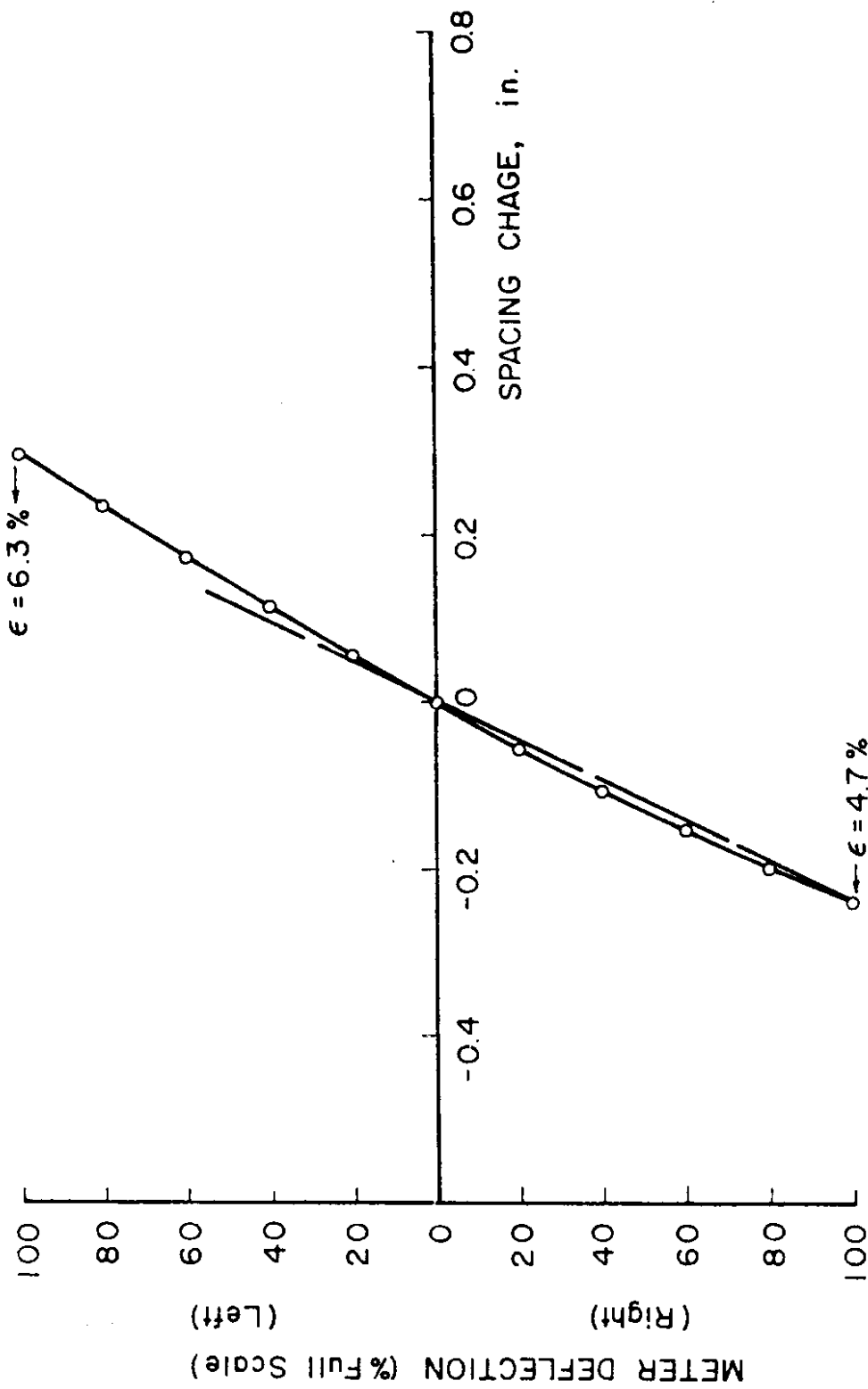

Figure 5-3. Meter Deflection in Response to Spacing Change (Range = 2, Amp Dial = 800, Initial Spacing = 4.80 in., Standard Sensitivity, Sensors = 2-in. diam)

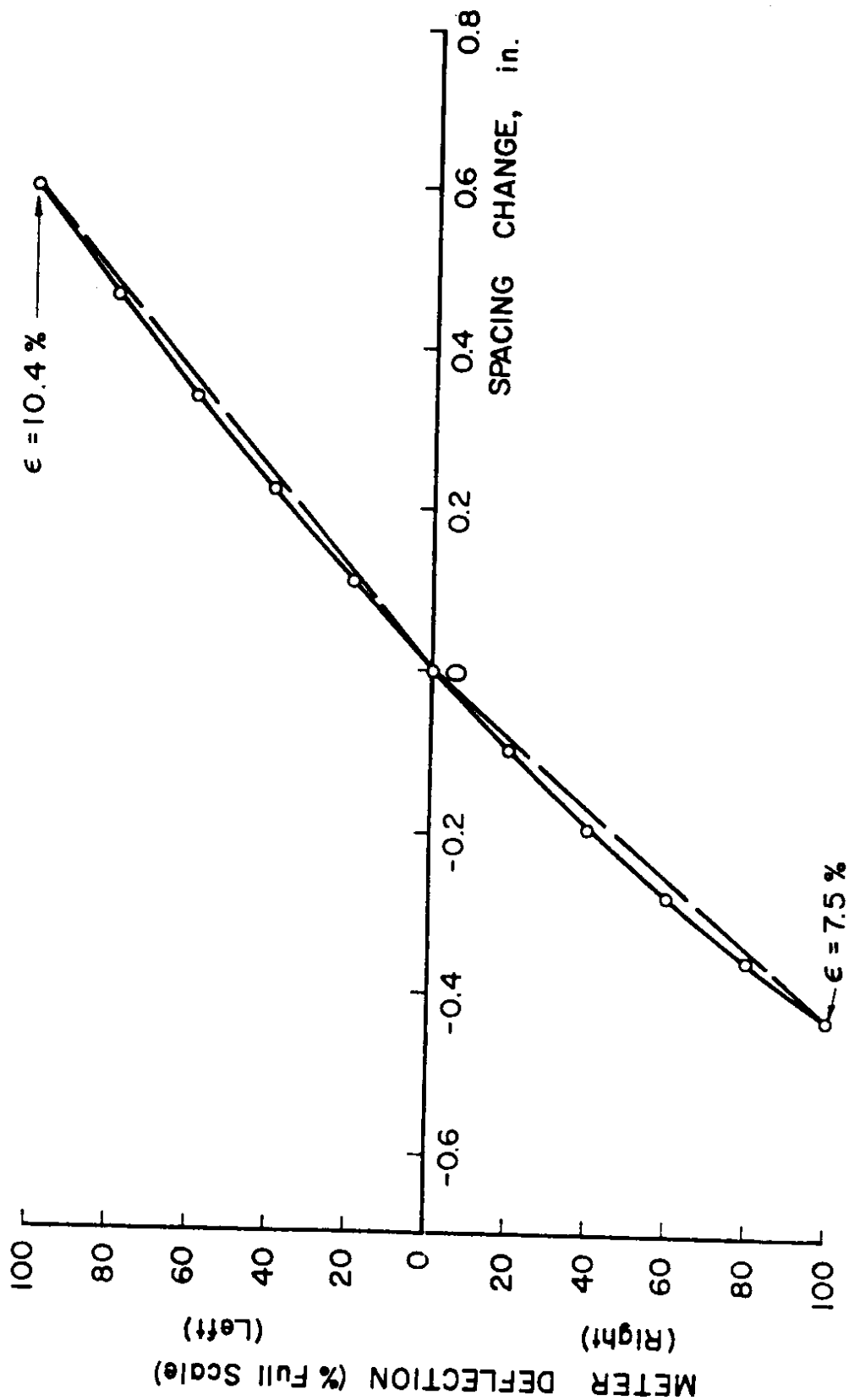

Figure 5-4. Meter Deflection in Response to Spacing Change (Range = 3, Amp Dial = 200, Initial Spacing = 5.69 in., Standard Sensitivity, Sensors = 2-in. diam.)

The instrument calibration dial permits setting sensitivity to provide a wide range of desired full scale strain. Standard sensitivity is defined as the sensitivity which produces full scale meter deflection for the calibration signal corresponding to a calibration dial reading of 1000. A different meter calibration curve, of course, will be obtained for each sensitivity selected. As an example, the calibration strain curves for standard sensitivity are shown in Figure 5-5. It is evident that the calibration strain increases rapidly with initial sensor spacing since an increase in amplitude reading and range represents an increase in spacing (Figure 5-1). Calibration strains can be made much lower by decreasing the calibration dial setting and increasing sensitivity.

The relationship between calibration strains at standard sensitivity (calibration dial 1000) and at other sensitivities are shown in Figures 5-6, 5-7 and 5-8 for ranges 1, 2 and 3 respectively at an AMPLITUDE setting of 500. The calibration ratio K represents the ratio of the full scale strain at the calibration setting indicated to the full scale strain at a setting of 1000. Since the maximum calibration dial setting is 1000, larger full scale strains are obtained by adjusting the sensitivity to produce meter deflections of less than full scale with the calibration dial set at 1000. Figures 5-6 and 5-7 show that the calibration dial setting is proportional to the full scale strain for ranges 1 and 2. This may be expected since the calibration strain at a setting of 1000 is less than 4% in both cases (Figure 5-5). The errors introduced for strains larger than a setting of 1000 are significant, however, especially in range 3. In range 3 the predicted strains would be less than actual strains in extension and too high in compression.

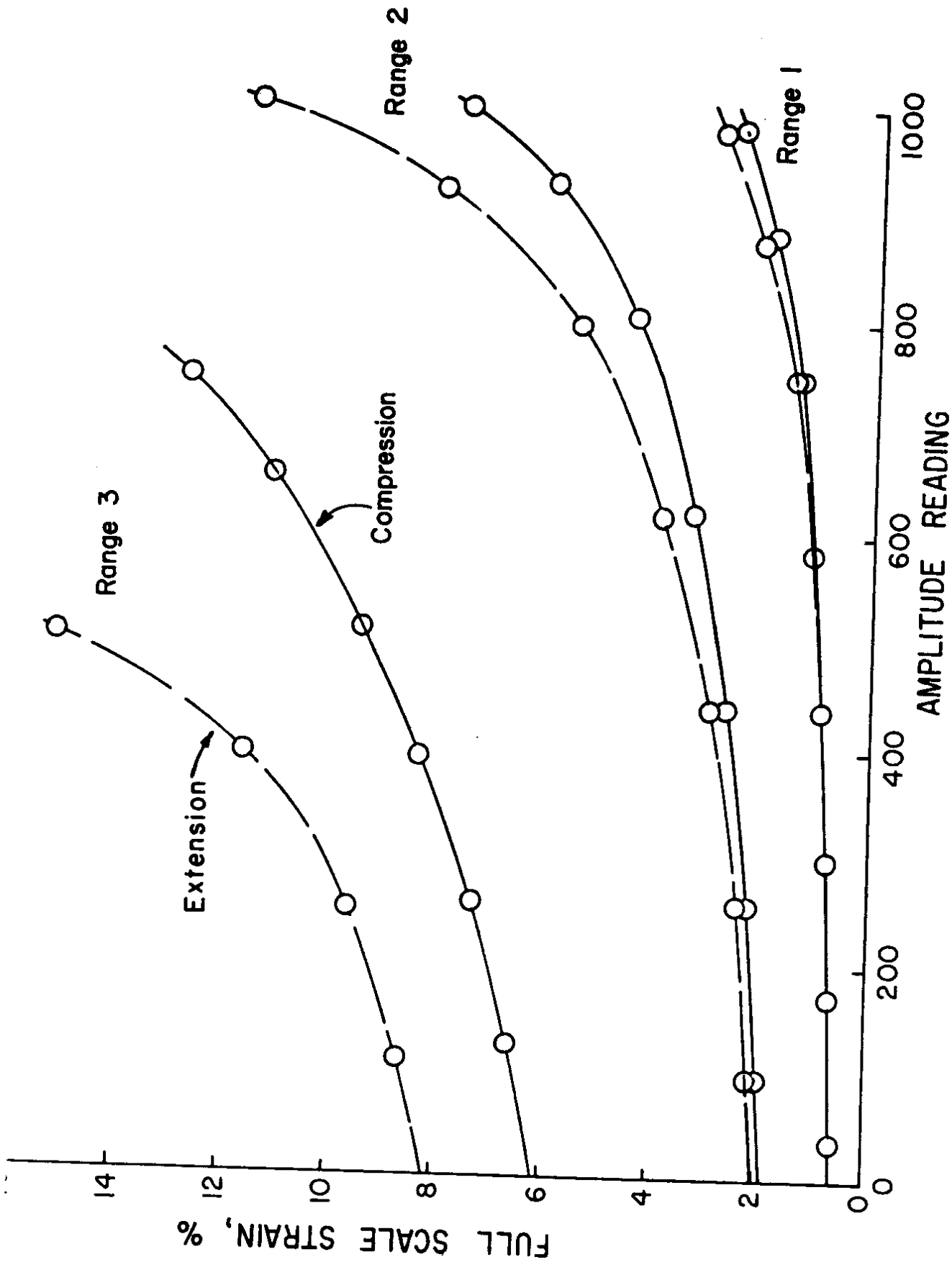

Figure 5-5. Meter Calibration Curves for Dynamic Instrument (Sensors = 2-in. diameter, Calibration Setting = 1000)

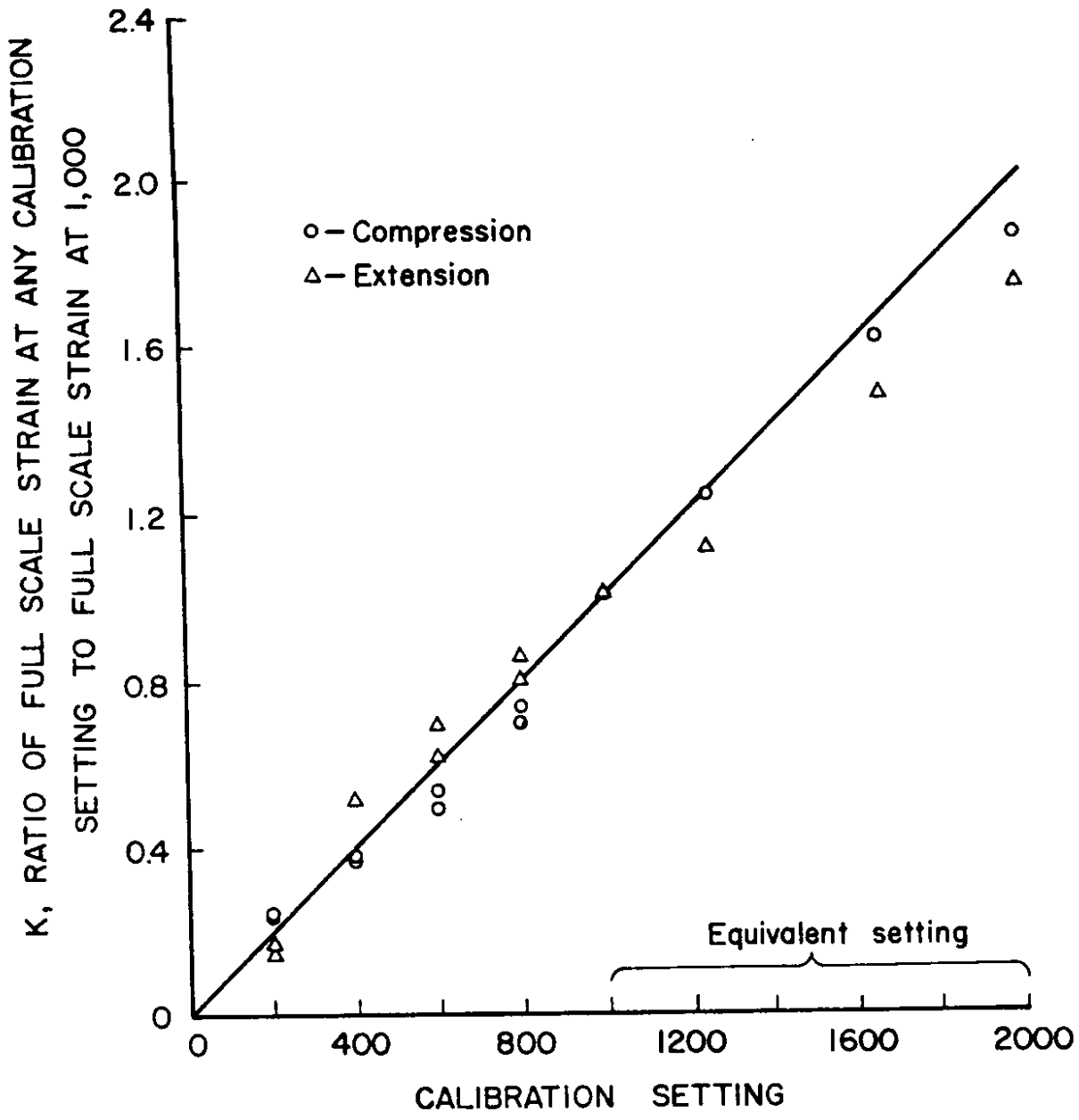

Figure 5-6. Variation of Calibration Strain with Calibration Setting (Range 1, Amp Dial = 500, Sensors = 2-in. diam)

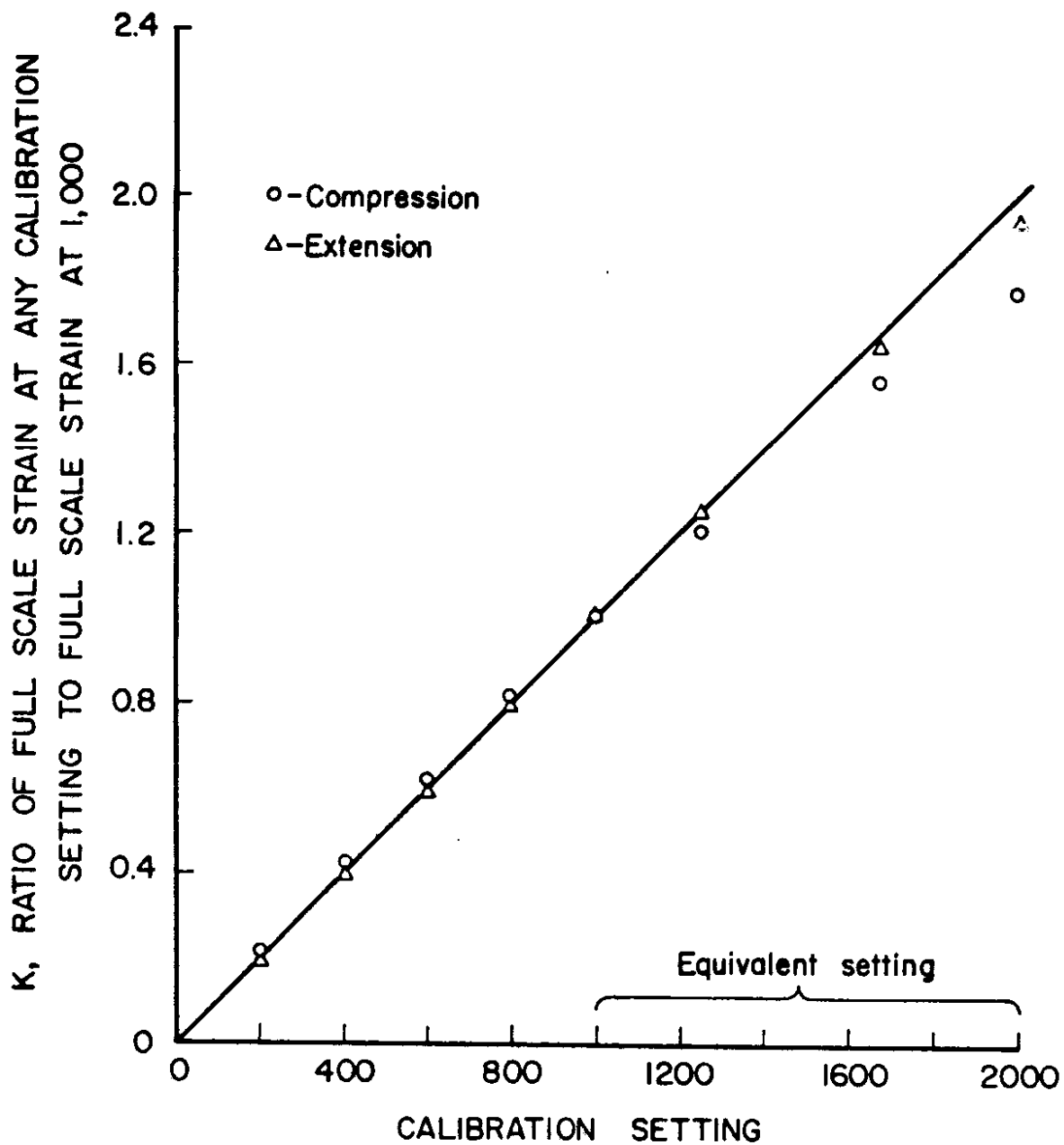

Figure 5-7. Variation of Calibration Strain with Calibration Setting (Range 2, Amp Dial = 500, Sensors = 2-in. diam)

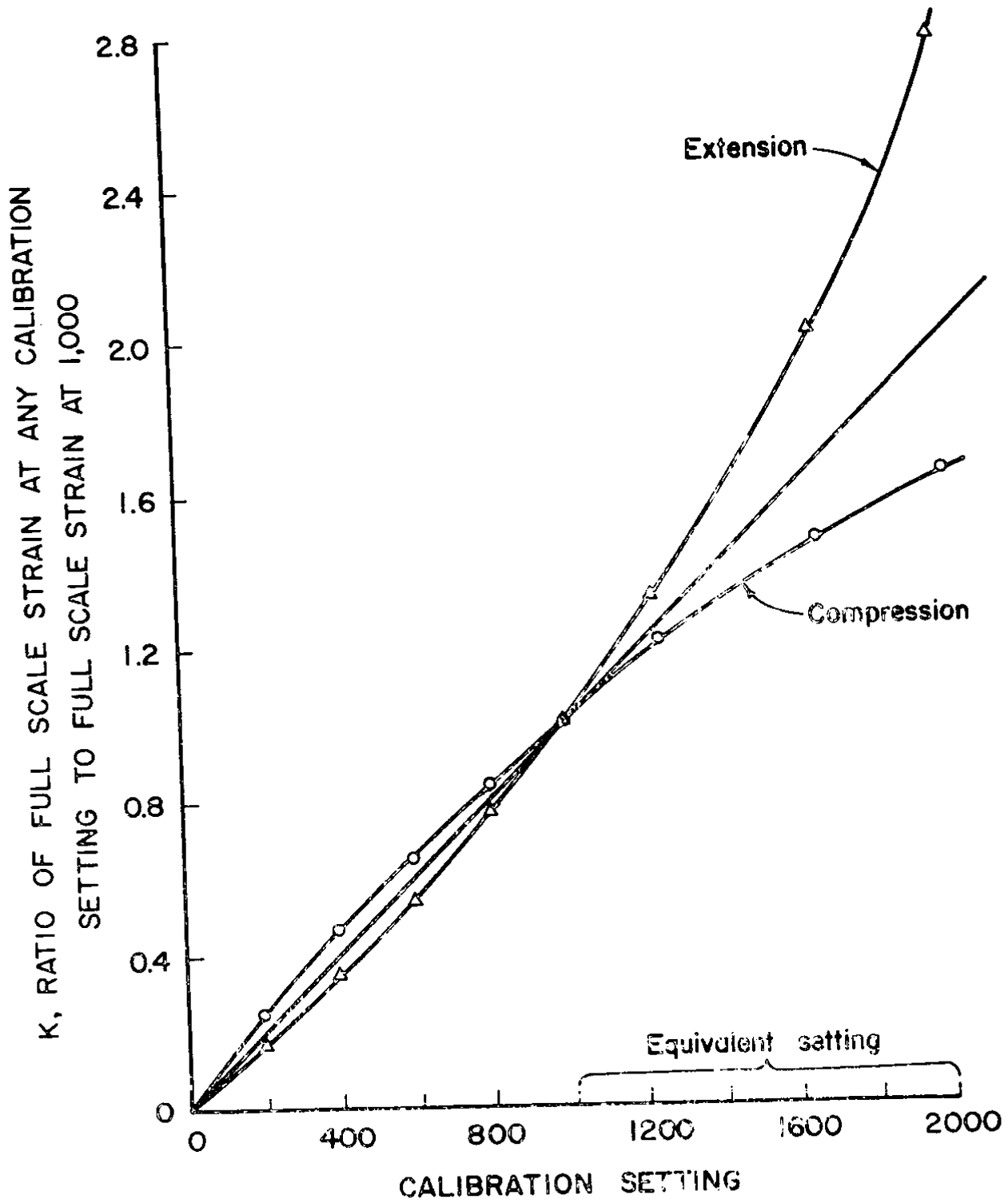

Figure 5-8. Variation of Calibration Strain with Calibration Setting (Range 3, Amp Dial = 500, Sensors = 2-in. diam)

Because of the nonlinearities of the type shown in Figure 5-2 through 5-4 and also of the type shown in Figure 5-6 through 5-8, it is evident that the calibration system is useful for data reduction only when strains are small. In such cases the availability of general curves such as given in Figure 5-5 is all that is necessary to compute strains.

For larger strain measurement accurate results can only be obtained if each combination of initial spacing and sensitivity is calibrated to provide a nonlinear voltage versus deflection curve. However, the calibration signal is used in these cases to reproduce the same sensitivity in the test as existed in obtaining the calibration curve. Even for large strains, the meter calibration curves in Figure 5-5 are useful for setting the sensitivity in advance of the test based upon an estimate of maximum strains expected when the exact calibration curves are not available.

When the instrument is operated in the null balance mode for measuring small strains a much better resolution is obtained if the calibration is represented in the form shown in Figure 5-9. The percent strain in relation to the initial spacing is determined by multiplying the change in amplitude dial readings with respect to the initial null amplitude reading by the factor obtained from Figure 5-9. Tests showed that within approximately $\pm 5\%$ strain no correction for nonlinearity is necessary.

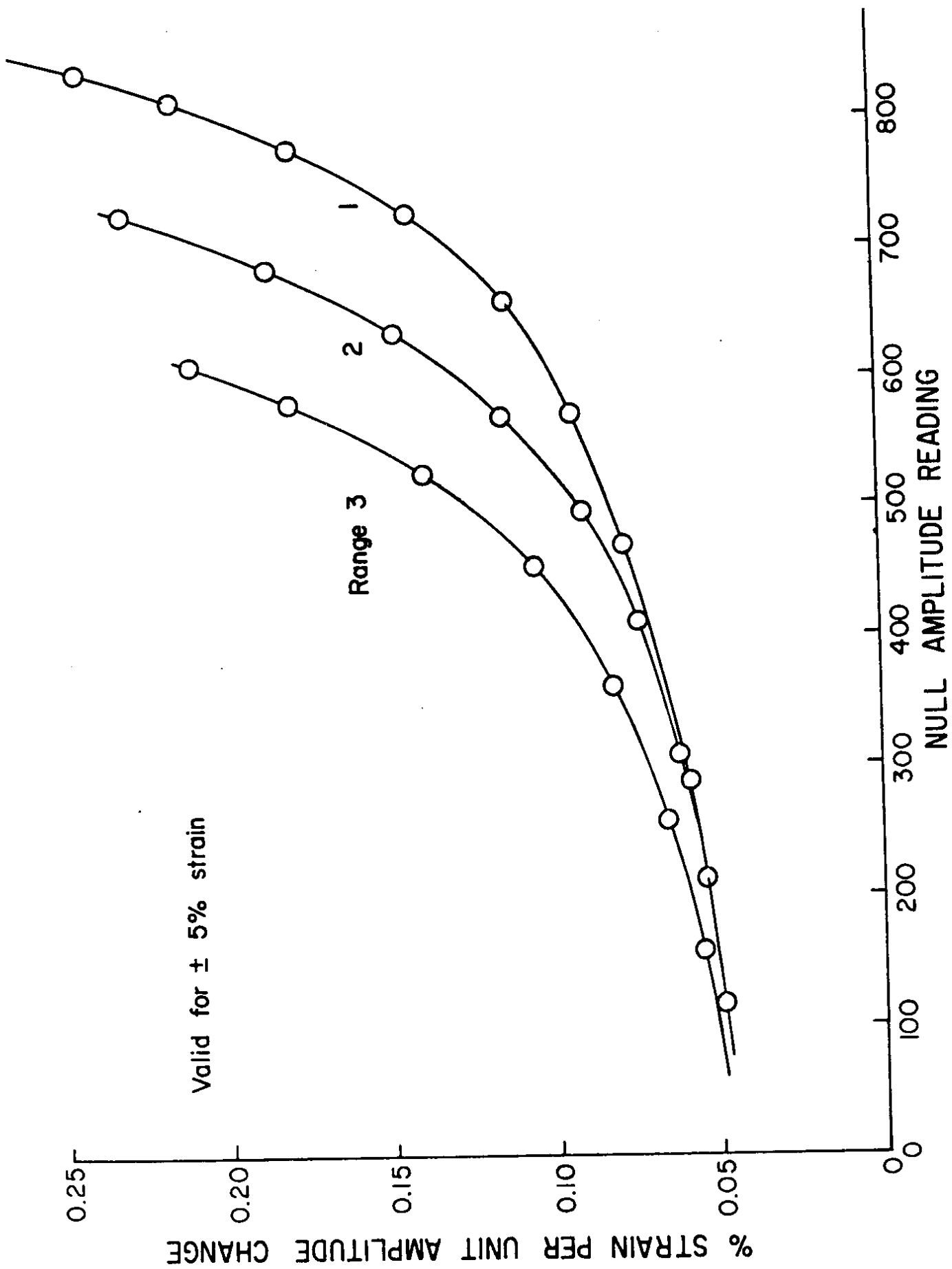

Figure 5-9. Strain Calibration of Amplitude Dial

VI. CALIBRATION PROCEDURES

A variety of calibration procedures are possible; the most satisfactory method will usually depend upon the specific application of the sensors. In many cases the easiest approach to data reduction is to recreate the measured AMPLITUDE or meter readings with a pair of sensors on the calibration fixture. The corresponding spacings and strains can be directly determined from the micrometer movements.

A procedure for obtaining each of the basic calibration curves for the 4101A instrument (Figs. 5-1, 5-5 and 5-9) will be outlined below. The principal purpose of these procedures is to provide a general understanding of the performance characteristics of the instrument. Deviations from these procedures are permissible for the experienced operator who may wish to simplify, extend or otherwise modify the calibration data to fit his particular purpose.

A. Spacing Calibration

The basic calibration curve for the strain gage is a plot of sensor spacing versus AMPLITUDE dial reading, one for each COIL SEPARATION range (Fig. 5-1). Although this relationship is quite consistent from instrument to instrument and from sensor to sensor, in general it is best to calibrate each pair of sensors with the cables and instruments to be used in order to get maximum accuracy. However when a number of sensors are to be used with similar cable lengths and the same instrument, calibration of one pair of sensors of each

size will be sufficient. The procedure for obtaining this calibration curve follows. A suggested data sheet is shown in Fig. 6-1.

1. Set up a pair of sensors on calibration fixture at about 3-1/2 diameters separation. Check system as in Steps 1 through 7 of Section IV. Be sure OSC. SELECT and REF. SELECT switches on rear panel are in INT. position and COIL SEPARATION is in position 3.

2. This calibration can be done at any instrument sensitivity. The higher the sensitivity, the greater the precision, but the nulling procedure is more difficult. A good compromise is to set sensitivity using the standard calibration signal as follows: Be sure phase and amplitude are nulled. Set CAL SIGNAL dial at 1000. Deflect CALIBRATE switch and adjust SENSITIVITY control until meter deflects 100 units left of the null position. Release CALIBRATE switch. If meter does not return to null, repeat zero check (Step 2 of Section IV). This sensitivity will be termed standard sensitivity.

3. Set AMPLITUDE dial at 1000. Retract micrometer to minimum position. Move sliding sensor mount until the meter is at or to the left of center (null). Using micrometer and PHASE balance control obtain amplitude and phase balance respectively. If amplitude balance requires retracting the micrometer beyond its range, reposition sliding sensor mount. If simultaneous phase and amplitude balance can not be achieved decrease AMPLITUDE setting until null is possible.

FIGURE 6-1

DATA SHEET FOR SOIL STRAIN GAGE SPACING CALIBRATION



Name _____ Date _____

Instrument No. _____

Coil Size _____ Cable Length _____

CAL SIGNAL _____ Meter Deflection _____

COIL SEPARATION _____ 1, _____ 2, _____ 3 Initial Spacing _____

<u>AMPLITUDE</u>	<u>Micrometer Reading, in.</u>	<u>Micrometer Adjustment*, in.</u>	<u>Micrometer Change, in.</u>	<u>Sensor Spacing, in.</u>
------------------	--------------------------------	------------------------------------	-------------------------------	----------------------------

* Used when sliding mount must be moved to permit reset of micrometer.

4. Measure sensor spacing (center to center or inside to outside distance) as accurately as possible. It is generally best to measure spacing at several points on circumference and average them. This value represents the maximum spacing for which null balance can be achieved in this range position.

5. Set AMPLITUDE dial at a smaller value, say about 900. Advance micrometer to decrease sensor spacing until approximate amplitude null is achieved. Adjust phase and amplitude balance so that both are nulled. Record micrometer setting and AMPLITUDE dial reading.

6. Repeat Step 5 for AMPLITUDE settings of about 800, 700, 600, 500, 400, 300, 200, 100, and 000. If range of micrometer is exceeded, establish a phase and amplitude balance at the end of the range and record micrometer reading and AMPLITUDE dial. Without changing instrument, retract micrometer and advance sliding mount until meter is approximately nulled. Adjust micrometer to obtain exact null and record new micrometer reading. The difference in these two micrometer readings must be subtracted from each subsequent micrometer reading to get the corrected readings.

7. Switch COIL SEPARATION to position 2 and repeat Steps 3 through 6. Repeat procedure again for COIL SEPARATION position 1.

8. Compute spacings at each AMPLITUDE reading by subtracting the corresponding micrometer readings from the initial spacing for each range. Plot results in a form such as given in Fig. 5-1.

Note the range of sensor spacings within which phase and amplitude balance can be obtained for each range. There is overlap of the ranges so that the sensors can be balanced at any spacing from the minimum of range 1 through the maximum of range 3.

The calibration curve in Fig. 5-1 serves two functions. The first is to give the initial spacing for a pair of sensors embedded in low magnetic susceptibility soil. This value is obtained by balancing the instrument and then reading the sensor spacing on Fig. 5-1 corresponding to the AMPLITUDE reading and COIL SEPARATION range. The second function of Fig. 5-1 is to determine change in spacing which when divided by the initial spacing (gage length) gives strain. After strain has occurred, the instrument may be rebalanced and the new spacing determined from Fig. 5-1. The change is obtained by subtracting this value from the initial spacing. This procedure for determining strain is only accurate for large strains, however.

B. Meter Calibration

In situations such as when strains are small or when changes are fast enough so that rebalancing is not possible between readings or when rebalancing is not desired to save time in reading, the meter deflection or external recorder may be used for measuring strains. The calibration switch is used to convert voltage to strain in these cases. It is helpful in setting sensitivity to have a calibration curve relating full scale meter deflection to the corresponding strain (Fig. 5-5). The procedure for this calibration can be most conveniently

accomplished at the same time as the spacing calibration. A suggested data sheet is given in Figure 6-2.

1. Set up a pair of sensors on calibration fixture at about 3-1/2 diameters separation. Check system as in Steps 1 through 7 of Section IV. Be sure OSC. SELECT and REF. SELECT switches on rear panel are in INT. position and COIL SEPARATION is in position 3.
2. Be sure phase and amplitude are nulled. Set CAL SIGNAL dial at 1000. Deflect CALIBRATE switch and adjust SENSITIVITY control until meter deflects to 100 units to the left of null. Release CALIBRATE switch. If meter does not return to null, repeat zero check (Step 2 of Section IV).
3. Measure sensor spacing (center to center or inside to outside distance) as accurately as possible. It is generally best to measure spacing at several points on the sensor circumference and average the values. Record sensor spacing.
4. With phase and amplitude balance achieved, record AMPLITUDE dial reading and micrometer setting.
5. Advance micrometer to decrease sensor spacing until meter deflects to 80 to the right of null. Record micrometer setting.
6. Retract micrometer to increase sensor spacing until meter deflects to 80 to the left of null. Record micrometer setting.
7. Repeat Steps 3 through 5 for other sensor spacings in COIL SEPARATION ranges 1, 2 and 3.

Figure 6-2

DATA SHEET FOR SOIL STRAIN GAGE METER CALIBRATION

Name _____ Date _____
 Instrument No. _____ Sensor Size _____
 Cable Length _____ COIL SEPARATION 1, _____ 2, _____ 3 _____
 CAL SIGNAL _____ Meter Deflection _____

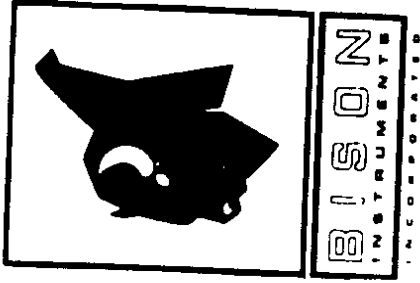

Null Balance Conditions

Sensor Spacing(s), in. AMPLITUDE Micrometer(M_i), in. _____

80% Full Scale
 Micrometer(M_f), in. _____ Left _____ Right _____

Micrometer
 Change ($M_f - M_i$), in. _____ Left _____ Right _____

Strain (ϵ), %
 Compression _____ Extension _____

8. Compute change in sensor spacing for 80% full scale meter deflection right and left. Compute percent strain (ϵ) by the relationships:

$$\epsilon = \frac{M_f - M_i}{s} \left(\frac{100}{0.8} \right)$$

where

ϵ = percent strain (positive = extension,
negative = compression),

M_f = micrometer reading at 80% full scale deflection,

M_i = micrometer reading at null balance, and

s = initial sensor spacing.

9. Plot results as in Fig. 5-5. A separate set of curves will be obtained for compression strains and extension strains.

As an approximate guide, the meter deflection may be considered a linear function of strain for full scale strains less than 12% in extension and 5% in compression with at most 10% error in strain. For example a meter reading of 50 for a full scale calibration strain of 12% would represent 6% strain accurate to $\pm 0.6\%$ strain or better. For larger strains a nonlinear calibration may be obtained using the calibration fixture. Examples of meter deflection as a function of strain are given in Figs. 5-2, 5-3 and 5-4.

The meter may be calibrated in the manner described above for other sensitivities (CAL SIGNAL values). However, for lower sensitivities than used with CAL SIGNAL = 1000, the full scale strain will be

approximately proportional to the ratio of CAL SIGNAL values. For larger sensitivities nonlinearities generally require recalibration.

The calibration curves in Fig. 5-5 are particularly useful for setting sensitivity in advance of a test. This procedure is as follows:

1. Balance instrument (phase and amplitude) with sensors installed in the soil. Determine the compression strain corresponding to full scale meter deflection from Fig. 5-5 based upon the existing AMPLITUDE reading and COIL SEPARATION range at this balance point (the procedure for extension strains is identical, only the calibration values change).
2. To establish this full scale sensitivity set the CAL SIGNAL dial at 1000 and adjust the SENSITIVITY control to give full scale deflection from null when the CALIBRATE switch is depressed.
3. If the expected maximum compression strain is considerably less than given in Fig. 5-5, the desired sensitivity is established by proportionately reducing the CAL SIGNAL dial reading and adjusting the SENSITIVITY control (rotate clockwise) to obtain full scale meter deflection for this new setting. For example, assume that the calibration strain read from Fig. 5-5 is 4%. If a full scale strain of 2% is desired, set the CAL SIGNAL dial to 500 and increase the sensitivity to give full scale deflection when the CALIBRATE switch is depressed. This new meter calibration will be accurate for COIL SEPARATION ranges 1 and 2, and approximate for range 3.

4. If the expected maximum compression strain is greater than the calibration strain in Fig. 5-5, the sensitivity is adjusted so that the meter deflection is proportionately less than full scale when a CAL SIGNAL of 1000 is used. For example, assume that the calibration from Fig. 5-5 is 4%. If a full scale strain of 8% is desired set the CAL SIGNAL dial to 1000 and decrease the sensitivity to give a meter deflection of 50. This new calibration generally will be low for extension strains and high for compression strains in COIL SEPARATION range 3, and too low in both cases for ranges 1 and 2. The error increases as the magnitude of calibration strain increases, therefore the calibration values should be checked using the calibration fixture, if accurate results are desired. Whether or not the calibration values are used, the CAL SIGNAL provides a means of precisely resetting the instrument sensitivity if the controls are changed for any reason.

When a recorder is attached to the 4101A instrument a deflection of the recorded trace is produced when the CALIBRATE switch is depressed. This deflection corresponds to the strain given in Fig. 5-5 when the CAL SIGNAL dial is set at 1000. Values for other dial settings are proportionately less in most cases as indicated in the discussion of meter calibration. The determination of strain at any time on a recorded trace is simply a matter of multiplying the ratio of sensor trace deflection to calibrate deflection by the calibrate strain as long as the strains are not so large that the

nonlinear characteristics of the system produce unacceptable error.

C. Dial Calibration

When strains are small and the instrument can be rebalanced the calibration values can be most accurately presented in the form shown in Fig. 5-9. A suggested data sheet is given in Fig. 6-3.

The procedure is as follows:

1. Set up a pair of sensors on the calibration fixture at about 3-1/2 diameters separation. Check system as in steps 1 through 7 of Section IV.
2. Using standard sensitivity, null phase and amplitude.
3. Measure sensor spacing (center to center or inside to outside distance) as accurately as possible.
4. Record AMPLITUDE dial reading and micrometer setting.
5. Adjust micrometer to increase sensor spacing by 4% (80% of 5%) of the initial spacing.
6. Record new AMPLITUDE dial reading and micrometer setting.

The operator may choose to adjust or not adjust the phase before taking this new reading. If the phase control is disturbed between readings, as, for example when the instrument is used for other sensors and then returned, then phase must be rebalanced for each reading.

Whichever choice is made should also be followed in making strain measurements in the soil. However, the difference will be small if the calibration strains are 4 per cent.

Figure 6-3

DATA SHEET FOR SOIL STRAIN GAGE DIAL CALIBRATION

Name _____ Date _____
 Instrument No. _____ Sensor Size _____
 Cable Length _____ COIL SEPARATION _____ 1, _____ 2, _____ 3
 Phase Rebalance _____ Yes, _____ No Calibration Strain _____ %

Null Balance Conditions			Extension			
Sensor Spacing, in.	AMPLITUDE A_i	Micrometer (M_i) , in.	Micrometer Change, ΔM_i	New Micrometer $(M_i + \Delta M_i)$, in.	AMPLITUDE A_e	Change $A_e - A_i$

Compression			Average AMPLITUDE Change	Ratio, Calibration Strain to AMPLITUDE Change
New Micrometer $(M_i - \Delta M_i)$, in.	AMPLITUDE A_c	Change $A_i - A_c$		

7. Adjust micrometer to decrease sensor spacing by 4 per cent from the initial spacing. Record AMPLITUDE dial readings and micrometer setting.
8. Compute change in AMPLITUDE dial reading for both extension and compression. Divide the calibration strain by each of these values and the average of these values.
9. Repeat steps 2 through 8 for other sensor spacings in COIL SEPARATION ranges 1, 2 and 3.
10. Plot the results as indicated in Fig. 5-9.

Previous tests show that the relationship between strain and change in AMPLITUDE is essentially linear with a range of $\pm 5\%$ strain with a maximum error of 10% for all sensor spacings. The choice of 4 per cent for the calibration strain is based on taking 80% of 5 per cent to split the error. This procedure also permits the same calibration constants to be used for both extension and compression. Separate dial calibration curves can be plotted for extension and compression in the manner indicated for the meter calibration in Fig. 5-5. This will permit the calibration range to be extended with the same accuracy. The selection of suitable calibration strains and the associated errors due to nonlinearity can be readily determined by plotting strain versus AMPLITUDE change for any particular sensor spacing.

The procedure for using the dial calibration curve is as follows:

1. Balance PHASE and AMPLITUDE with sensors installed in the soil prior to any strain to be measured. Record AMPLITUDE and COIL SEPARATION range.

2. Obtain value of percent strain per unit amplitude change from Fig. 5-9 corresponding to this AMPLITUDE and range.
3. To obtain a strain measurement rebalance instrument (omit phase if appropriate for calibration curve) and record AMPLITUDE.
4. Multiply change in AMPLITUDE from step 1 and 3 by the calibration factor in step 2. Note whether the strain is extension or compression.

D. Rapid Calibration

The spacing and dial calibration methods in Sections A, B and C are time consuming to carry out if the entire range of spacing is considered. However, the curves may be obtained very rapidly using a special calibration fixture called a calibration comb. The micrometer fixture is more versatile than the comb, but not more accurate.

The calibration comb (Fig. 6-4) consists of a plastic plate with slots in it at precisely determined spacings. The values for the 4-in. sensor size are given in Fig. 6-4. The odd numbered slots are exactly 4% closer to the center slot than the succeeding even numbered slots. As a consequence the required calibration values are obtained by nulling the instrument in each of the comb positions. The procedure is as follows:

1. Attach one sensor to one of the support blocks and insert it in the center slot flush with the numbered edge of the slot.

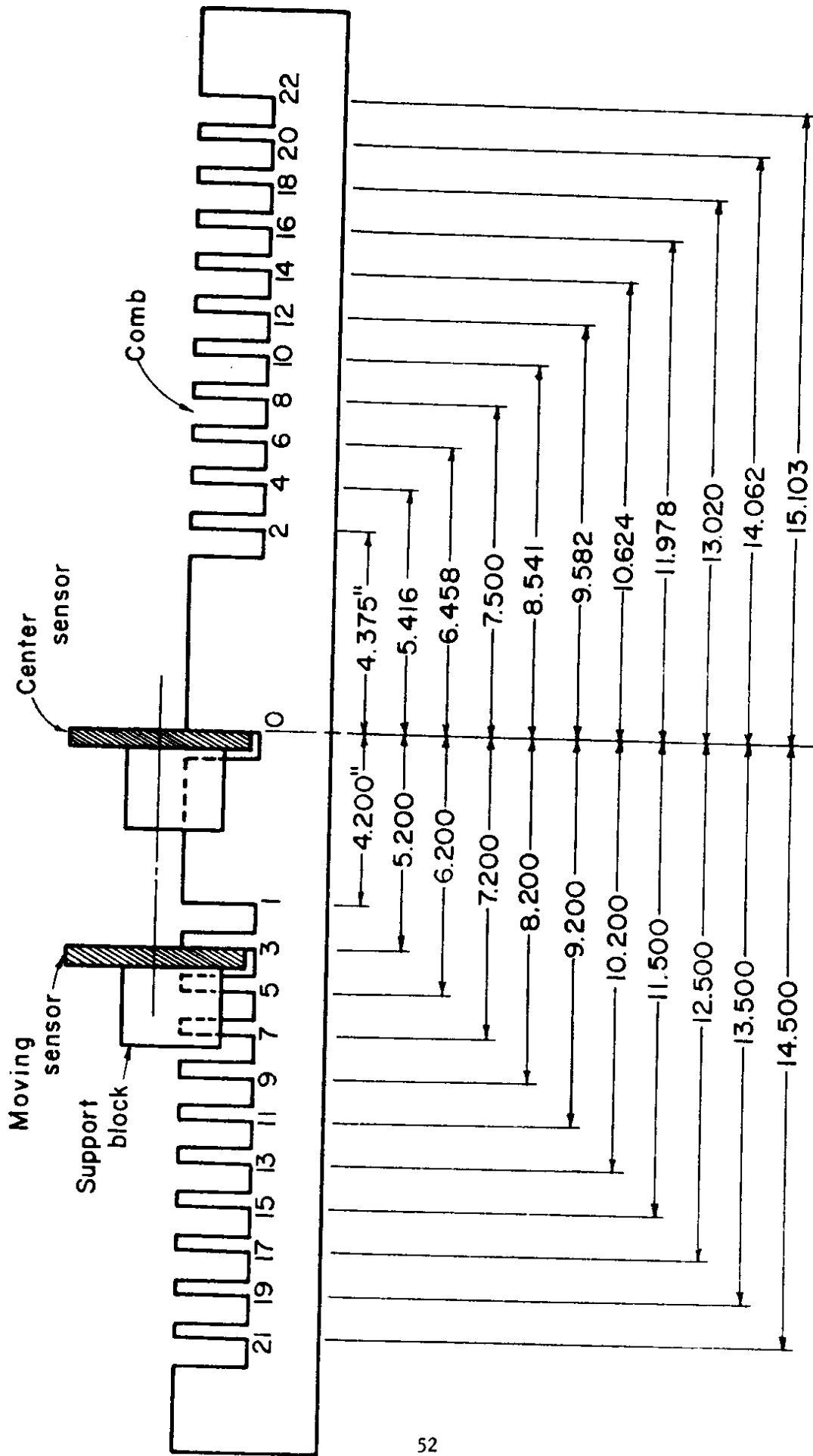

Figure 6-4. Calibration Comb Dimensions for 4-in. Sensor

2. Attach the second sensor to the other support block and insert it in slot number 1 flush with the numbered edge of the slot. Be sure the polarity is correct.

3. Set rear panel to range 1 and obtain AMPLITUDE and PHASE null. Record AMPLITUDE dial value on data sheet (Fig. 6-5).

4. Move sensor from position 1 to position 2 and obtain null. Record AMPLITUDE value.

5. Continue this process by nulling instrument in each of the remaining slots. Where the course balance ranges overlap, readings should be taken in both ranges. Sensors should always be flush with numbered side of slot.

6. Compute difference in AMPLITUDE values between positions 1 and 2, 3 and 4, 5 and 6, etc. Compute dial calibration factors for extension, compression and average by dividing the amplitude change into 4.16, 4.00 and 4.08 respectively as shown in Fig. 6-5. For convenience a curve as in Fig. 6-6 may be used to determine the factors without calculation.

7. Plot the results as shown in Figs. 6-7 and 6-8. These are the same curves as Figs. 5-1 and 5-9 except that they have been put in semilog form.

Figure 6-5

COMB CALIBRATION DATA SHEET
(4-in. Sensors)



Date _____ Operator _____ Instrument _____

Comb Position	Spacing, in.	Amplitude	Range	Δ Amp (Even-Odd)	% Strain/ Δ Amp*		
					Comp	Ext	Avg
1	4.20			-			
2	4.38			-			
3	5.20			-			
4	5.42			-			
5	6.20			-			
6	6.46			-			
7	7.20			-			
8	7.50			-			
9	8.20			-			
10	8.54			-			
11	9.20			-			
12	9.58			-			
13	10.20			-			
14	10.62			-			
15	11.50			-			
16	11.98			-			
17	12.50			-			
18	13.02			-			
19	13.50			-			
20	14.06			-			
21	14.50			-			
22	15.10			-			

* Comp = $\frac{4}{\Delta \text{ Amp}}$, Ext = $\frac{4.16}{\Delta \text{ Amp}}$, Avg. = $\frac{4.08}{\Delta \text{ Amp}}$

Plot Comp vs even Amp, plot Ext vs odd Amp, plot Avg vs Avg Amp.

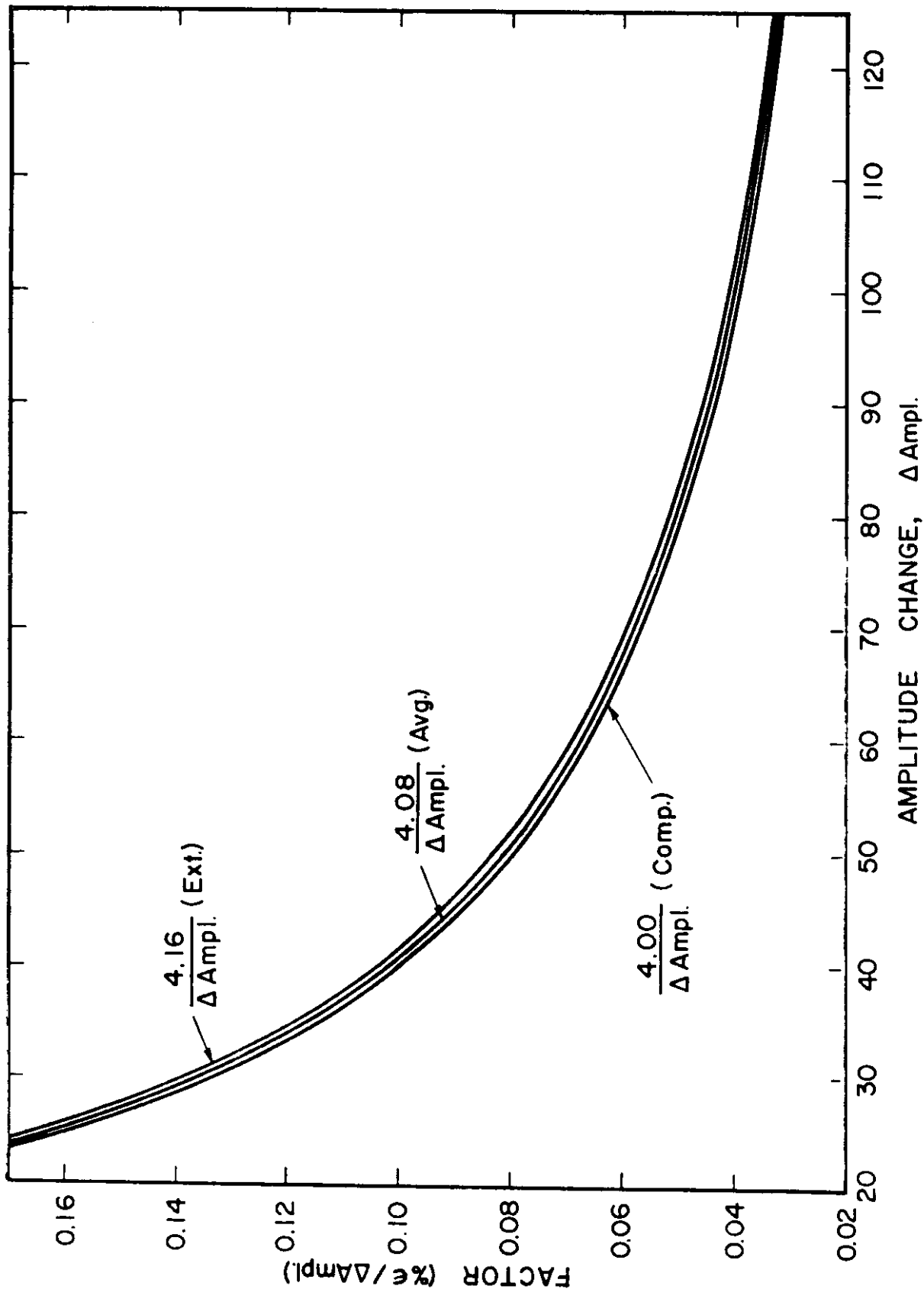

Figure 6-6. Factor Determination Curves

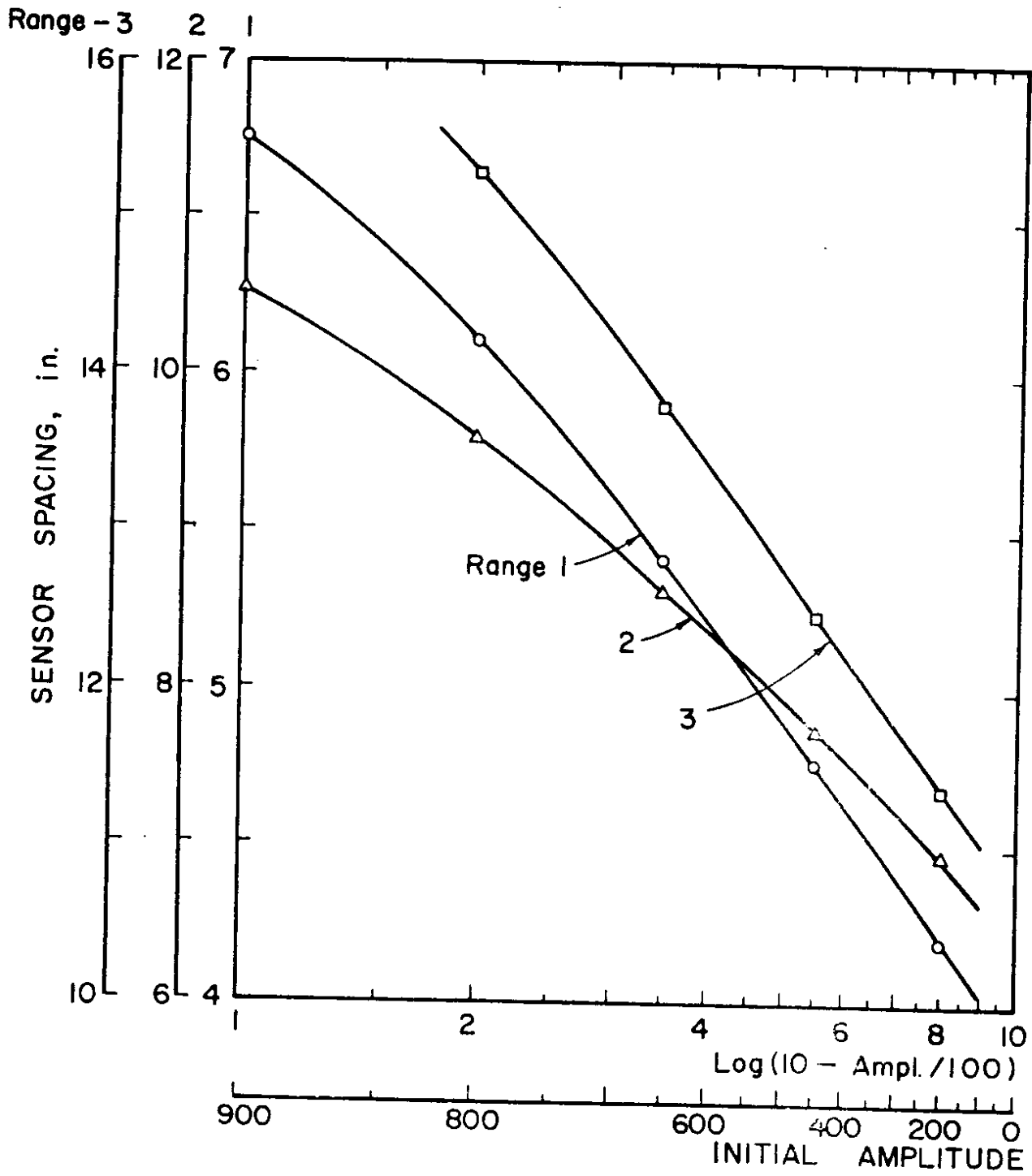

Figure 6-7. Spacing Calibration Curves for 4101A (4" Sensors, 50' Cable)

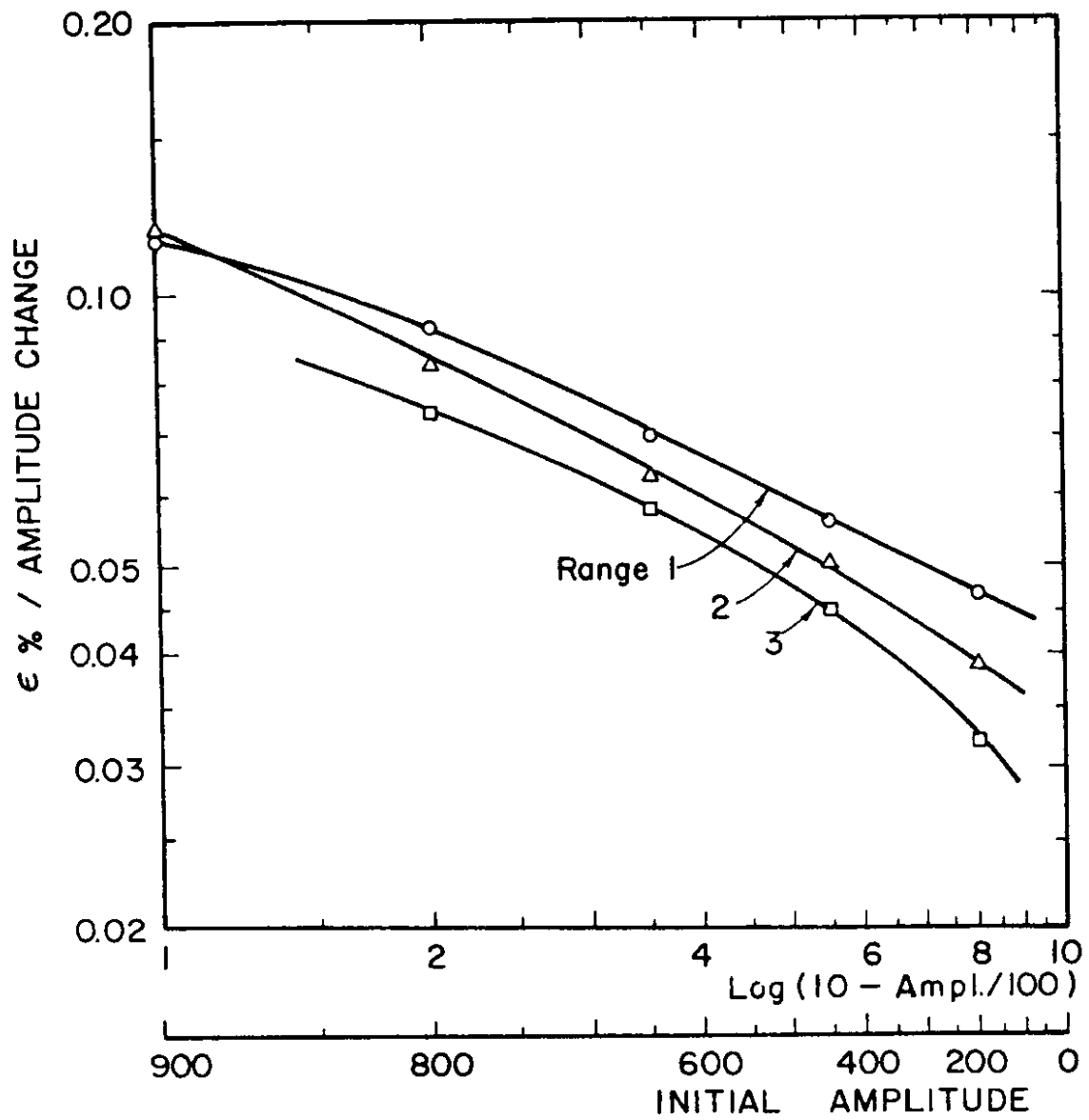

Figure 6-8. Strain Factor Calibration Curves for 4101A (4" Sensors, 50' Cables)

VII. SENSOR INSTALLATION

The method of sensor installation in the soil will depend upon the specific application. Techniques must be developed by each operator through experience. Several general procedures will be described which will aid in this task.

One of the conditions which has a major influence on placement technique is whether the soil is undisturbed or compacted. Except at exposed surfaces, when the sensors are applied to natural soil they must usually be placed in prepared holes which are subsequently backfilled. The soil in the vicinity of the sensors may be somewhat different in behavior as a result than the undisturbed parent soil. On the other hand in the case of compacted soil the sensors can be placed as the soil is deposited so that the soil around the sensors does not differ from the rest of the fill.

As an example consider the measurement of vertical strain in a fill consisting of 10-in. thick compacted layers (Fig. 7-1). Four-inch-diameter sensors would be required to span the entire thickness. The first sensor (A) would be placed flat on the prepared surface of layer 1. A hand level is desirable to insure horizontal sensor orientation. Layer 2 is then added to the fill and compacted making a layer about 10-in. thick. A second sensor (B) is placed horizontally on the surface of layer 2 and roughly over the lower sensor (A). Phase and amplitude are then nulled. The exact

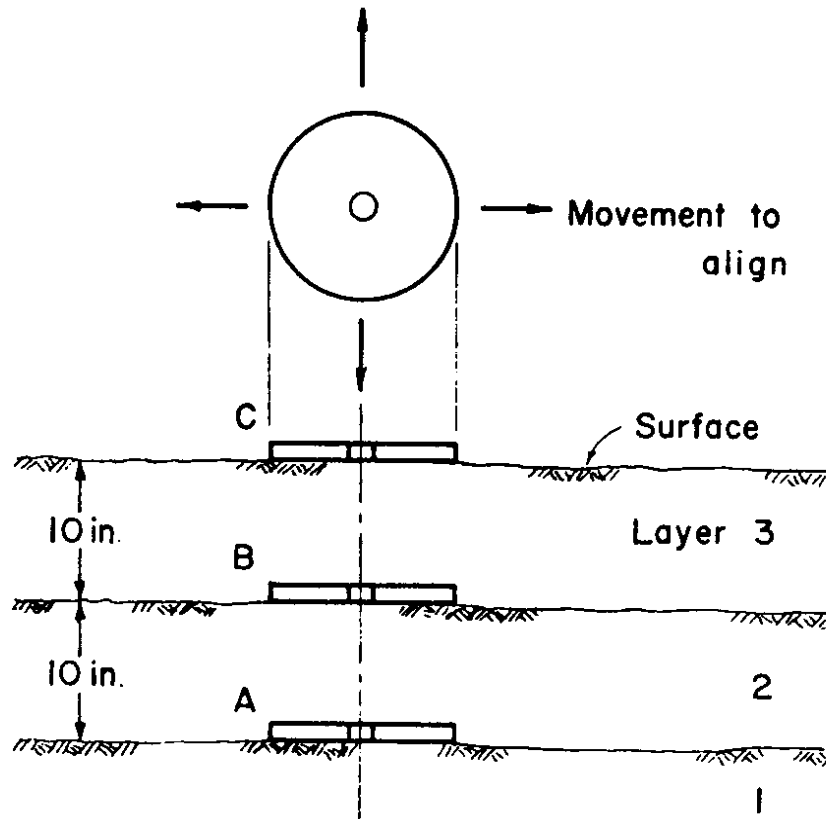

Figure 7-1. Electrical Centering of Sensors

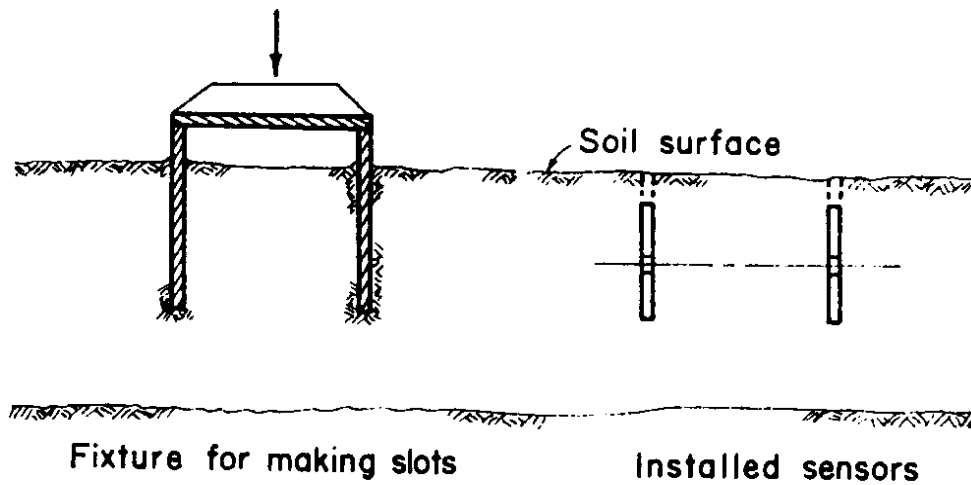

Figure 7-2. Installation for Horizontal Strain

coaxial alignment of the pair is obtained electrically using the meter on the instrument package. As the upper sensor (B) is moved horizontally across the surface the meter deflection will change. The maximum meter reading (deflection to the right) obtained after moving the upper sensor in two directions at right angles will correspond to coaxial alignment. The sensor (B) is then held in this position by placing additional loose soil above it. A final null balance is then obtained. The separation of sensors A and B can be obtained from the calibration curves rising the null AMPLITUDE dial reading.

It is evident that in this example the soil around the sensors has the same characteristics as that throughout each layer. Furthermore this procedure can be repeated at the top of each compacted layer so that the entire fill thickness can be included giving strain distribution as well as change in thickness. For example, in Fig. 7-1, the change in thickness between sensors A and C would be obtained by adding the measured change between A and B to that between B and C.

Horizontal strains can be measured in either of two ways. The first is to install the sensors with their axis horizontal. A simple fixture can be used for making two parallel vertical slots with the desired spacing (Fig. 7-2). The second method is to place both sensors in a coplainer configuration on the soil surface. This arrangement is shown in Fig. 8-6 with the corresponding spacing calibration curve. It is analogous in every respect to the parallel and coaxial arrangement. This coplainer approach is particularly useful in crushed stone and gravel materials in which slots can not be made.

VIII. SENSOR CONFIGURATION AND ALIGNMENT EFFECTS

A. Multiple Channel Use

This operations manual is primarily based on single channel operation. However, multiple channel situations are more likely to occur. Therefore some comments on the system capabilities in this regard are necessary.

If sufficient time is permitted between readings to allow rebalancing of the instrument then no limit exists on the closeness of spacing between sensor pairs. Any number of sensors can be monitored with the same readout by connecting each pair of sensors in turn to the instrument. A switch box is a convenient way to accomplish this task if more than one reading is to be obtained from each pair of sensors.

If each pair of sensors is attached to a separate instrument which is isolated electrically from the others and if an external recorder is not used, then the sensor pairs can be placed as close to each other as the spacing between the sensors in a given pair without a significant interaction.

When an external recorder is required for several channels simultaneously a beating effect between oscillator signals will produce noise which is unsatisfactory if the sensor sets are separated less than about 10 diameters. This noise problem can be eliminated by driving all instruments with the same oscillator. A provision for this exists on

each instrument. In this case, however, the separation of 10 diameters between pairs is still needed because with all of the sets interconnected their magnetic fields will overlap and produce output on adjacent channels. The magnitude of this effect can be determined easily by setting up several pairs of sensors and instruments and noting the change in output when one pair of sensors is moved relative to the others.

B. Offset and Rotation Effects

An important question concerns the effect of misalignment caused by sensor offset or rotation on the measurement of axial strains. Sensor spacing calibration curves were obtained for 2-in. sensors in range 2 with the sensors in coaxial alignment and also offset at 0.5 and 1.0 in. (Fig. 8-1). It is evident that the effect is not linear with offset. Over most of the range the effect of offset is essentially a parallel shift so that offset during placement would effect the estimate of gage length, but not the sensitivity used to compute change in spacing.

Fig. 8-2 compares the meter deflection for corresponding axial and parallel (offset) movements at a selected initial sensor spacing. The effect of offset increases rapidly with increasing misalignment, but for the same axial displacement as misalignment a signal at least an order of magnitude greater is obtained for the axial movement.

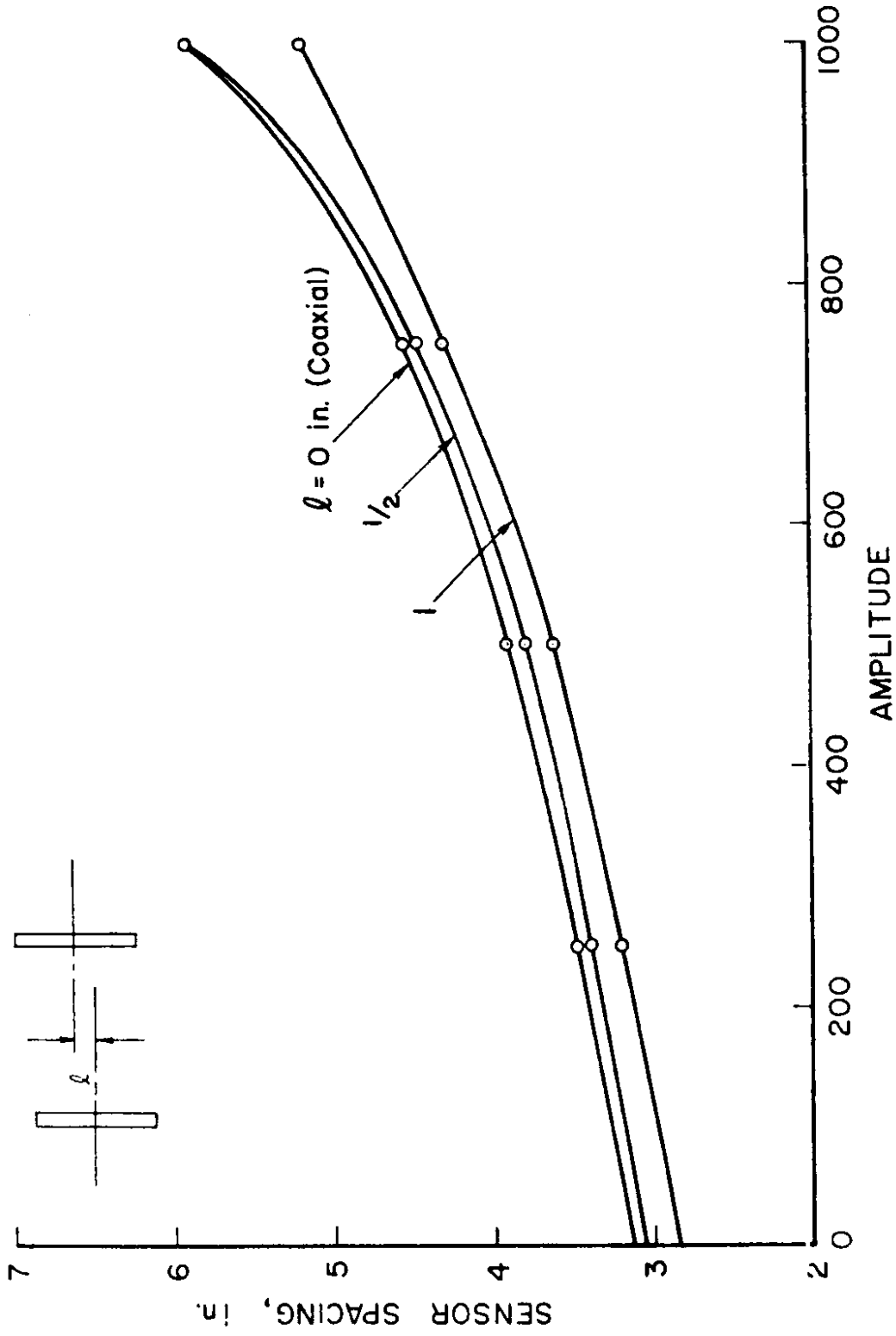

Figure 8-1. Effect of Lateral Misalignment on Sensor Spacing Calibration Curves
 (Range = 2, Standard Sensitivity, Sensors = 2-in. diam)

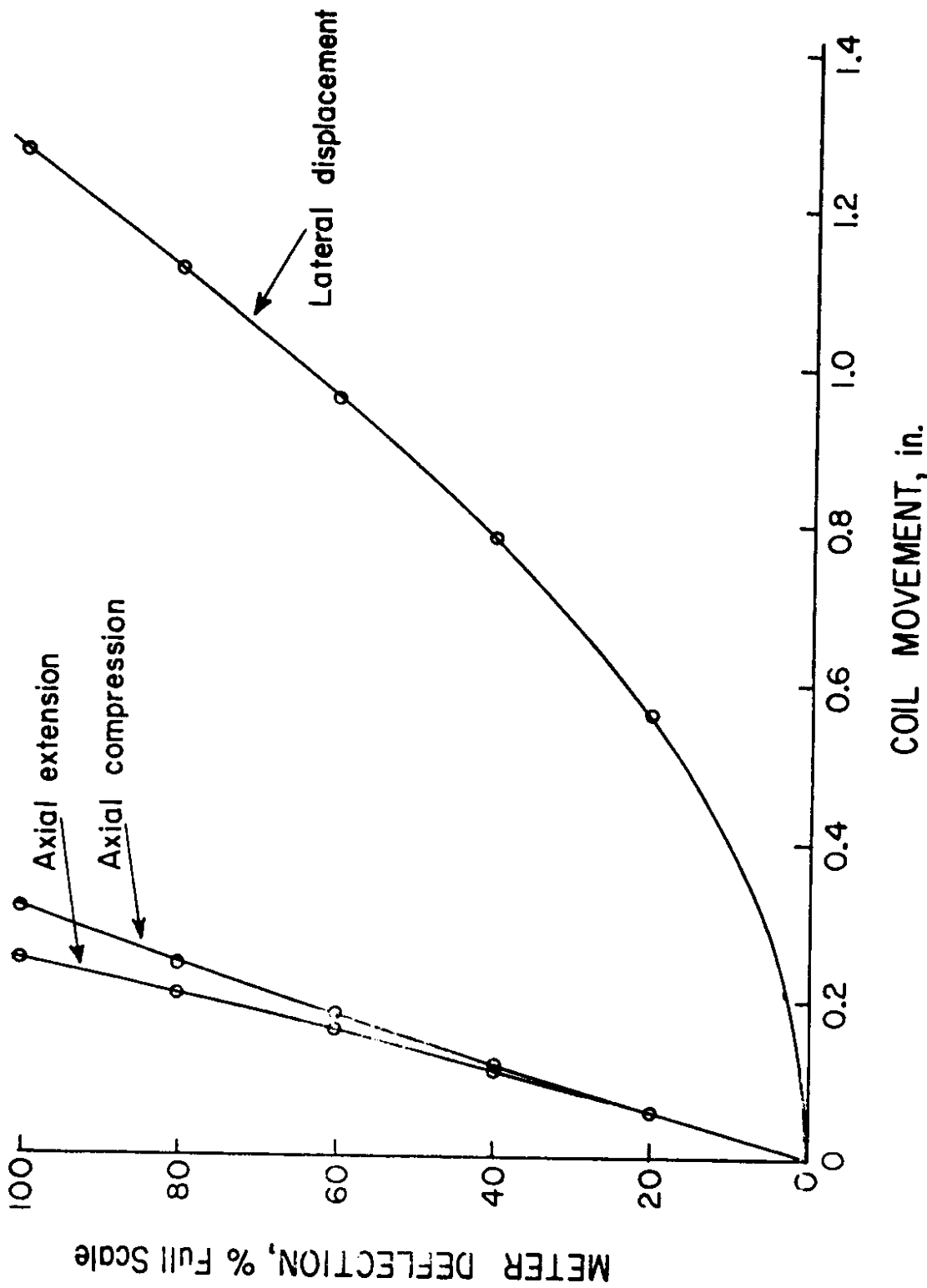

Figure 8-2. Effect of Lateral Misalignment Compared to Axial Displacement (Sensors = 2-in. diam, Initial Spacing = 5 in., Range = 2, Amp dial = 829, Standard Sensitivity)

Rotational effects are harder to evaluate because of the difficulty in producing rotation without axial movement. However some information is available from previous studies.* For angular rotation less than ± 10 deg the effect was not significant. For rotation less than ± 20 deg the error in strain sensitivity was generally less than 10%. These comparisons, of course, depend upon the amount of axial movement used as a reference.

C. Possible Configurations

The discussion thus far has only dealt with coaxial changes between a pair of sensors in parallel orientation. However, the instrument will also operate with the sensors in other configurations. A knowledge of these other situations is helpful in understanding the effects of selective sensor movements as well as in examining additional applications of the system.

First consider the cases in which sensors remain parallel but are laterally displaced out of coaxial alignment. There exist paths along which one of the sensors can be moved while the other is stationary such that no change in the instrument readings will be produced. These lines of "equal potential" are shown in Fig. 8-3. Maximum change in the readings will occur if the sensor is moved normally to these lines while maintaining parallel orientation.

* Truesdale, W.B. and R.B. Schwab, "Soil Strain Gage Instrumentation", Final Report for Air Force Weapons Laboratory, New Mexico, June 1965.

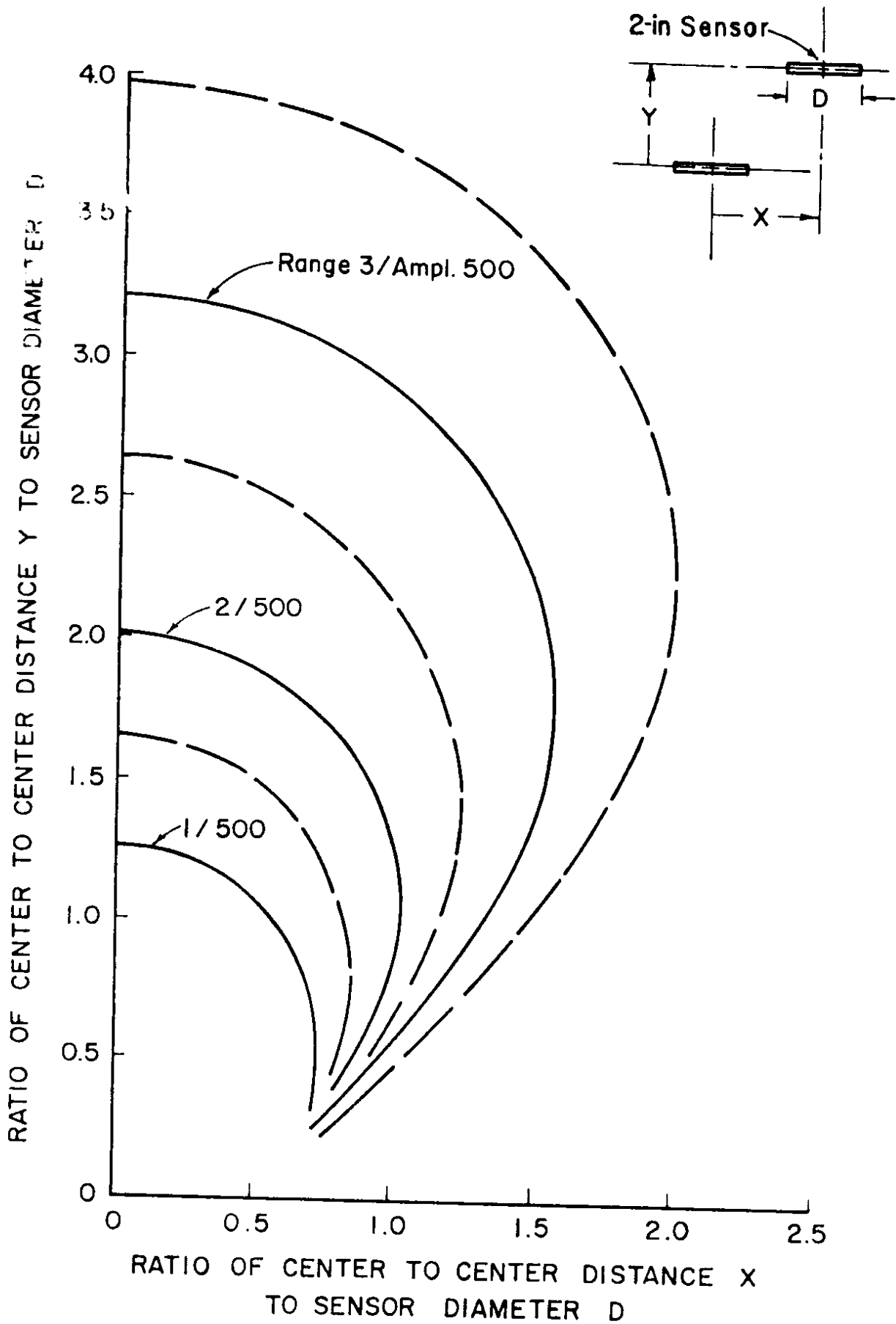

Figure 8-3. Lines of Equal Potential for Parallel Coil Configuration

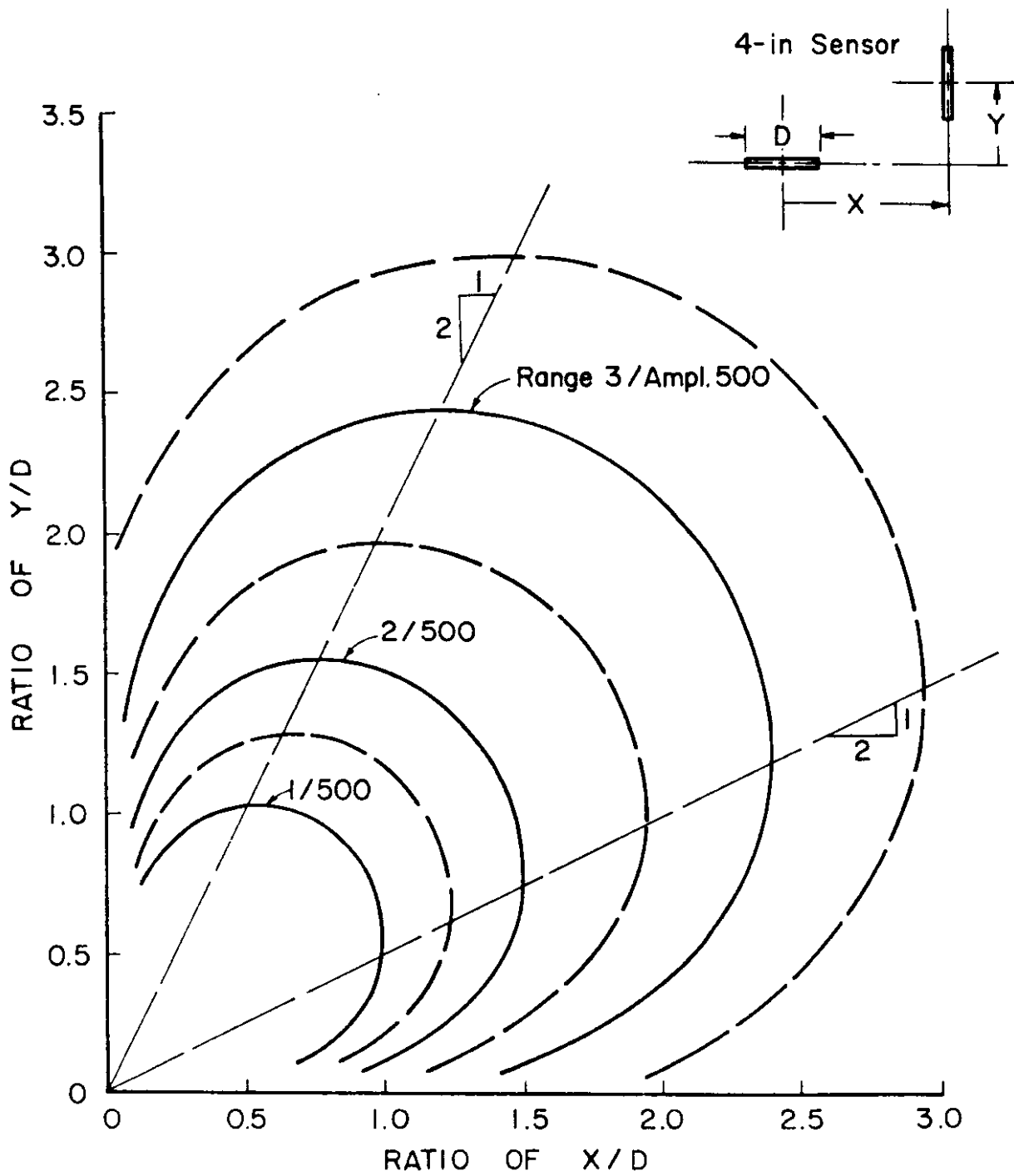

Figure 8-4. Lines of Equal Potential for Perpendicular Coil Configuration

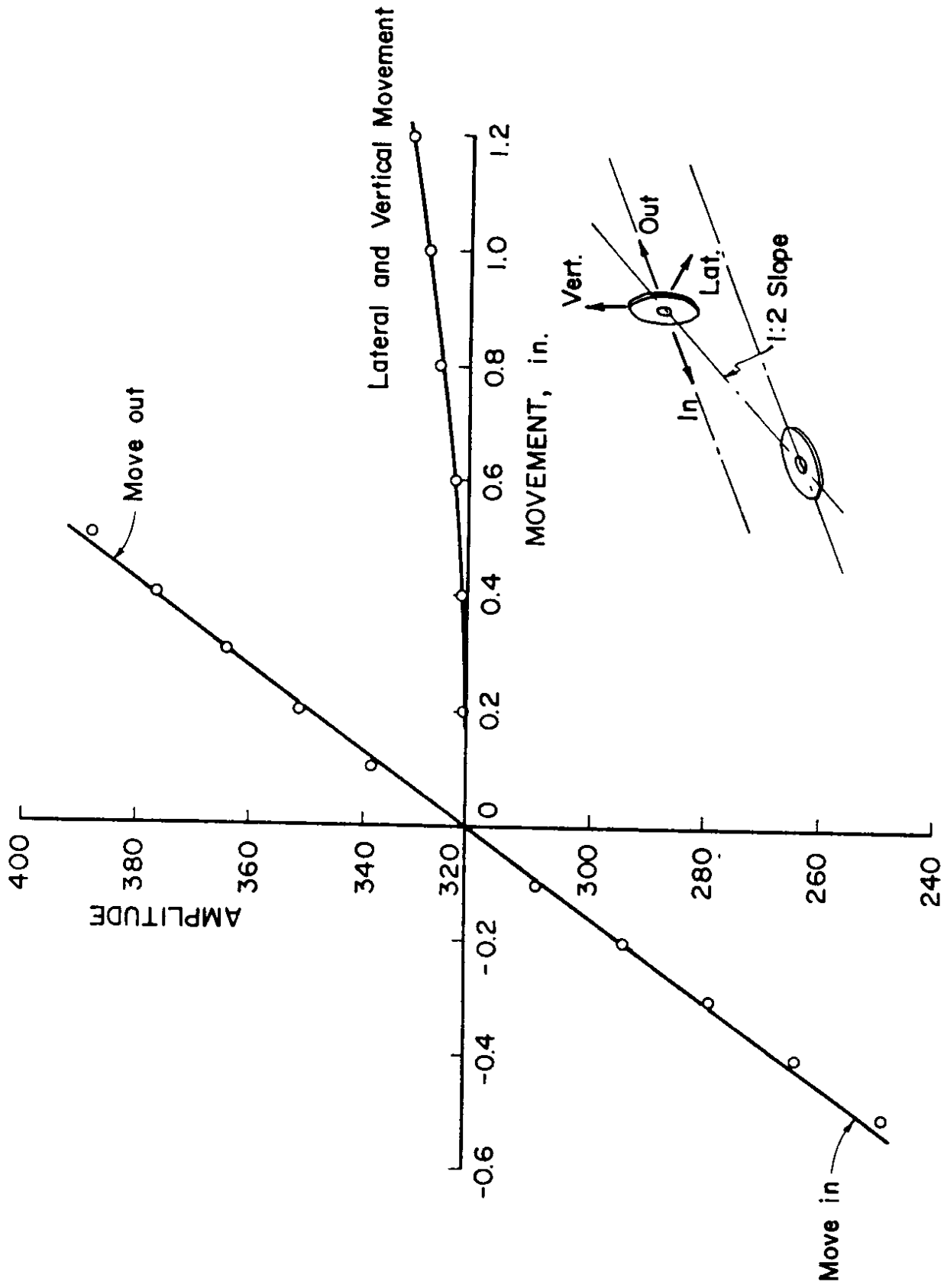

Fig. 8-5. Response of Sensors in Perpendicular Configuration

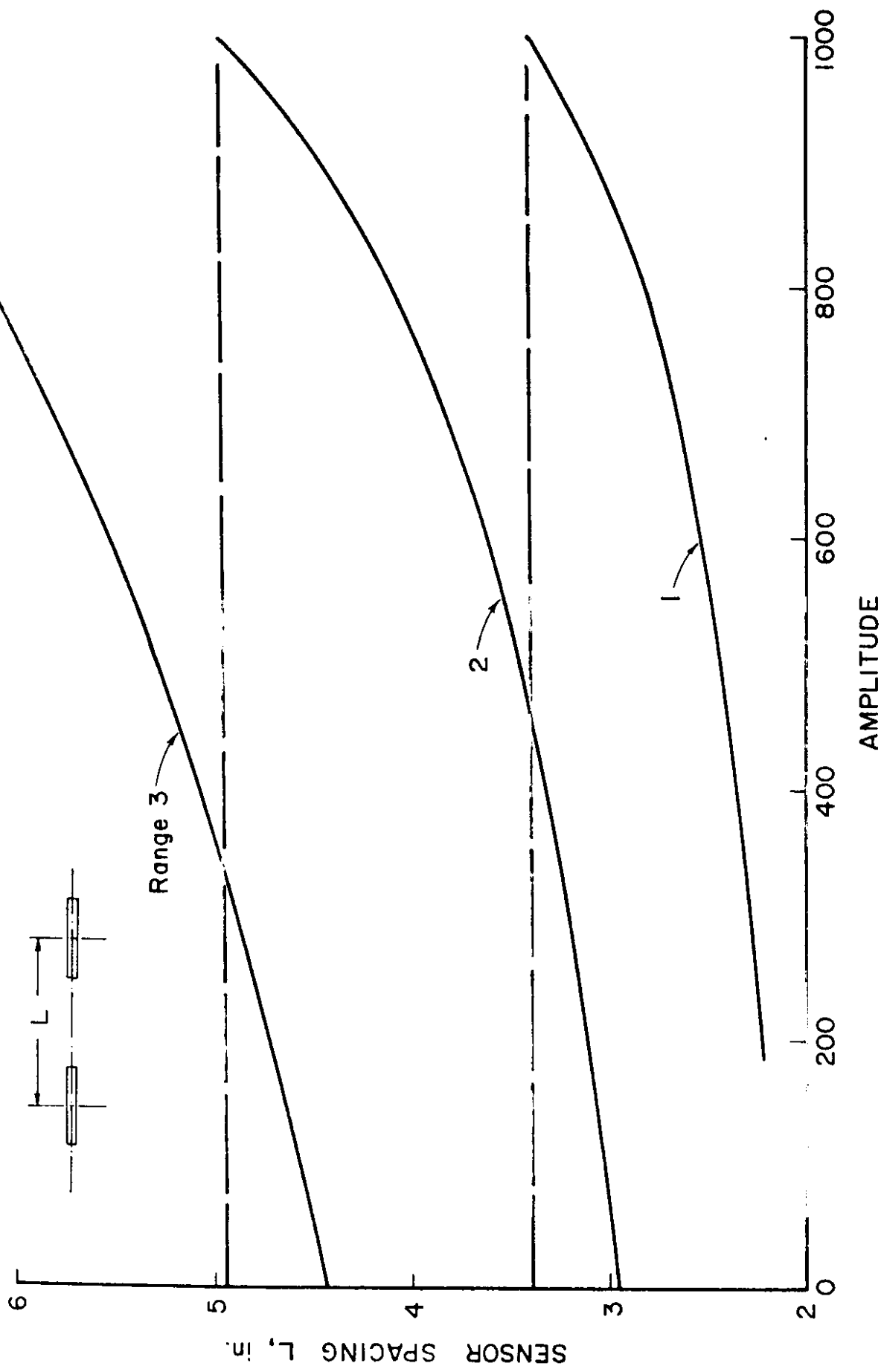

Figure 8-6. Sensor Spacing Calibration Curves in Coplaner Configuration

It is evident that coaxial changes of parallel sensors represents one situation which is normal to equal potential lines, therefore explaining the earlier observation (Fig. 8-2) that lateral movements produce changes which are secondary compared to axial changes.

The sensors will also balance when in a perpendicular configuration. Lines of equal potential in these cases are shown in Fig. 8-4. It may be seen that sensors placed at right angles with their centers on a line with approximately a 1:2 slope will be primarily responsive to movements of a shearing nature. Such a situation is represented in Fig. 8-5 which shows that movements defined as vertical and lateral produce negligible effects compared to in and out movements, i.e., normal to the equal potential lines.

The last example to be presented is the parallel and coplanar configuration. This situation is analogous to the parallel and coaxial one in the sense that the readings are affected primarily by changes in separation distance, but not by transverse and rotational changes. The corresponding spacing calibration curves in Fig. 8-6 are similar to those in Fig. 5-1 for the coaxial arrangement.

IX. APPLICATION

One of the first applications of this strain gage was to investigate the variation in strain in triaxial specimens.* Recorded strains in a conventional specimen were very nonuniform (Fig. 9-1a) while those in a short specimen having lubricated ends were found to be similar throughout the specimen (Fig. 9-1b).

The motivation for development of the strain gage came from a need to measure strains associated with shock propagation in soils. In one series of laboratory experiments the sensors were installed at various stations in long columns of confined clay together with stress gages and subjected to air shock loading.** From records of stress and strain as a function of time (Fig. 9-2) it was possible to construct and examine stress-strain relationships for soil accompanying wave propagation.

In another study vertical strains were measured in a laterally confined sample of soil subjected to several load cycles. Change in density was computed from the volumetric strains. The results (Fig. 9-3) show that density variations as small as 0.05 lb per cu ft could be detected. This is much better resolution than with any conventional method.

* Januskevicius, C.K. and E. Vey, "Stresses and Strains in Triaxial Specimens", ASTM Special Technical Publication 392, Instruments and Apparatus for Soil and Rock Mechanics, pp. 37-54, 1965.

** Hampton, D.H. and P.J. Huck, "Study of Wave Propagation in Confined Soils", Contract Report S-69-2 for Waterways Experiment Station, Vicksburg, Miss., June 1968.

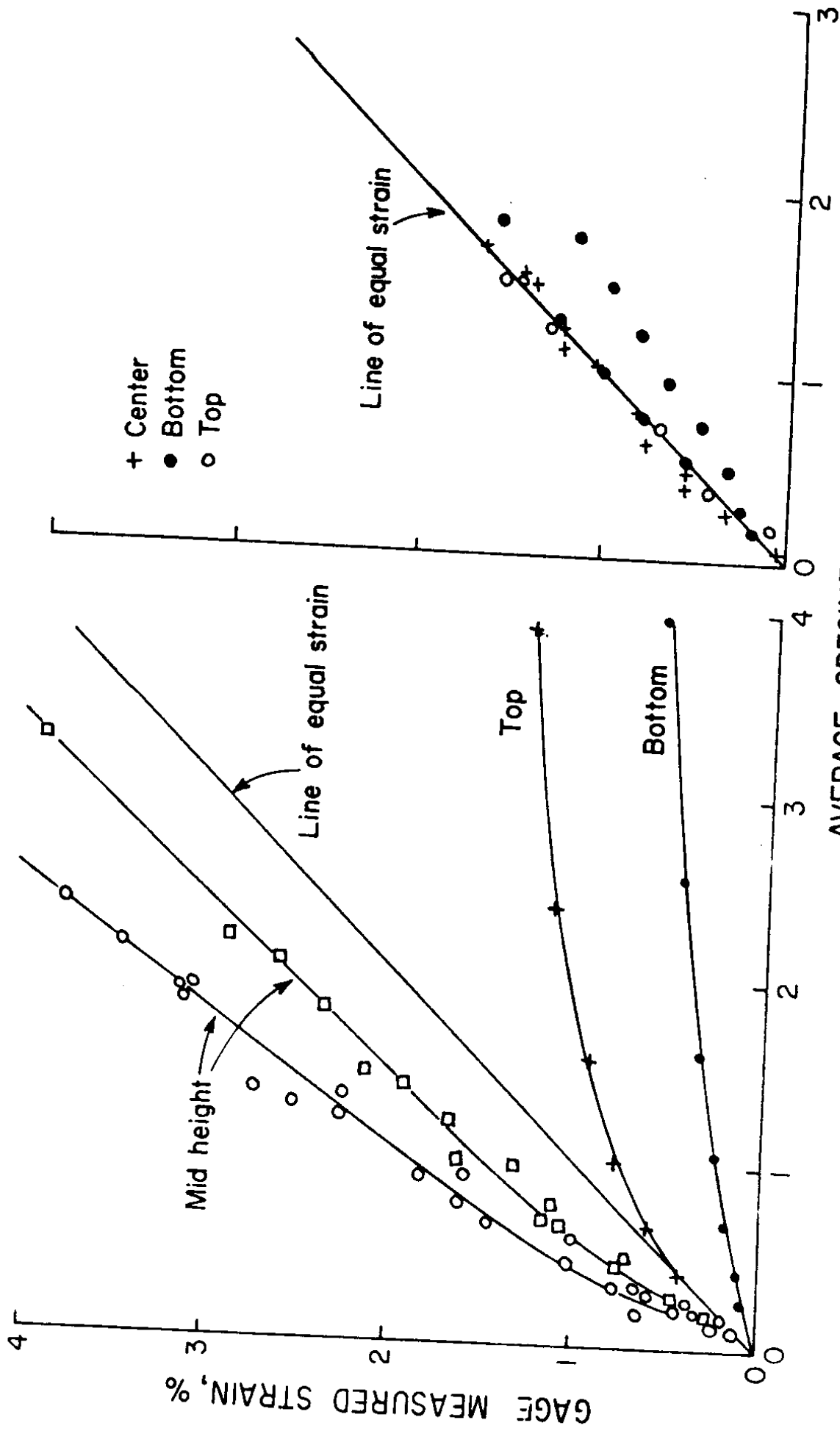

A) Specimen 6" diameter by 12" high with standard ends.

B) Specimen 6" diameter by 6" high with lubricated ends.

Figure 9-1. Axial Strains in Triaxial Specimens

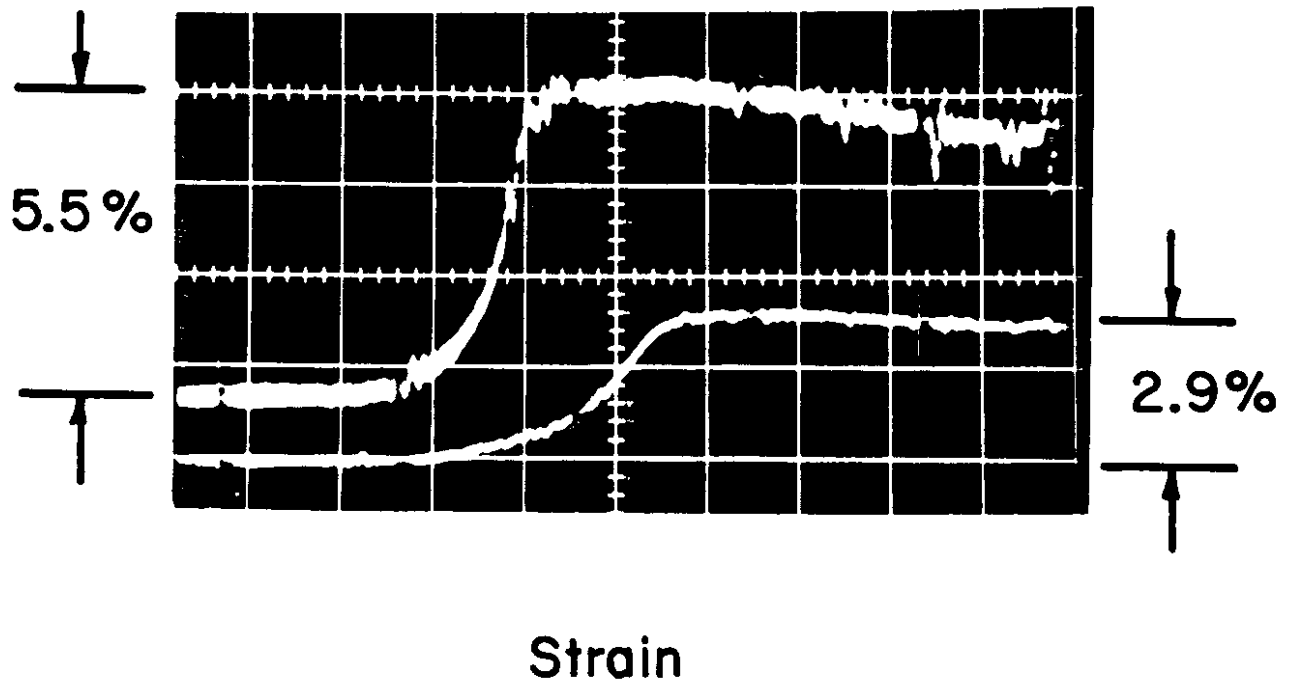
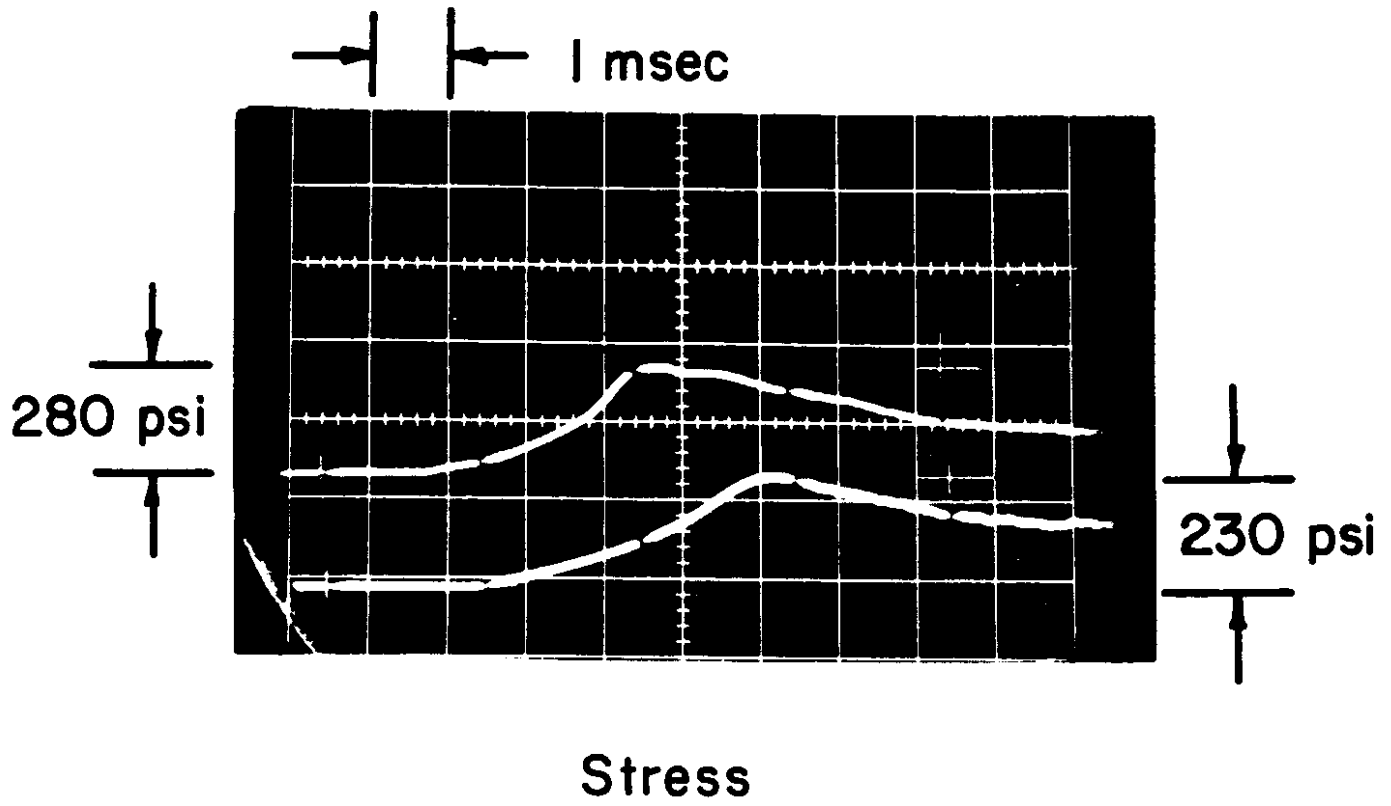

Figure 9-2. Stress and Strain Measurements During Shock Propagation

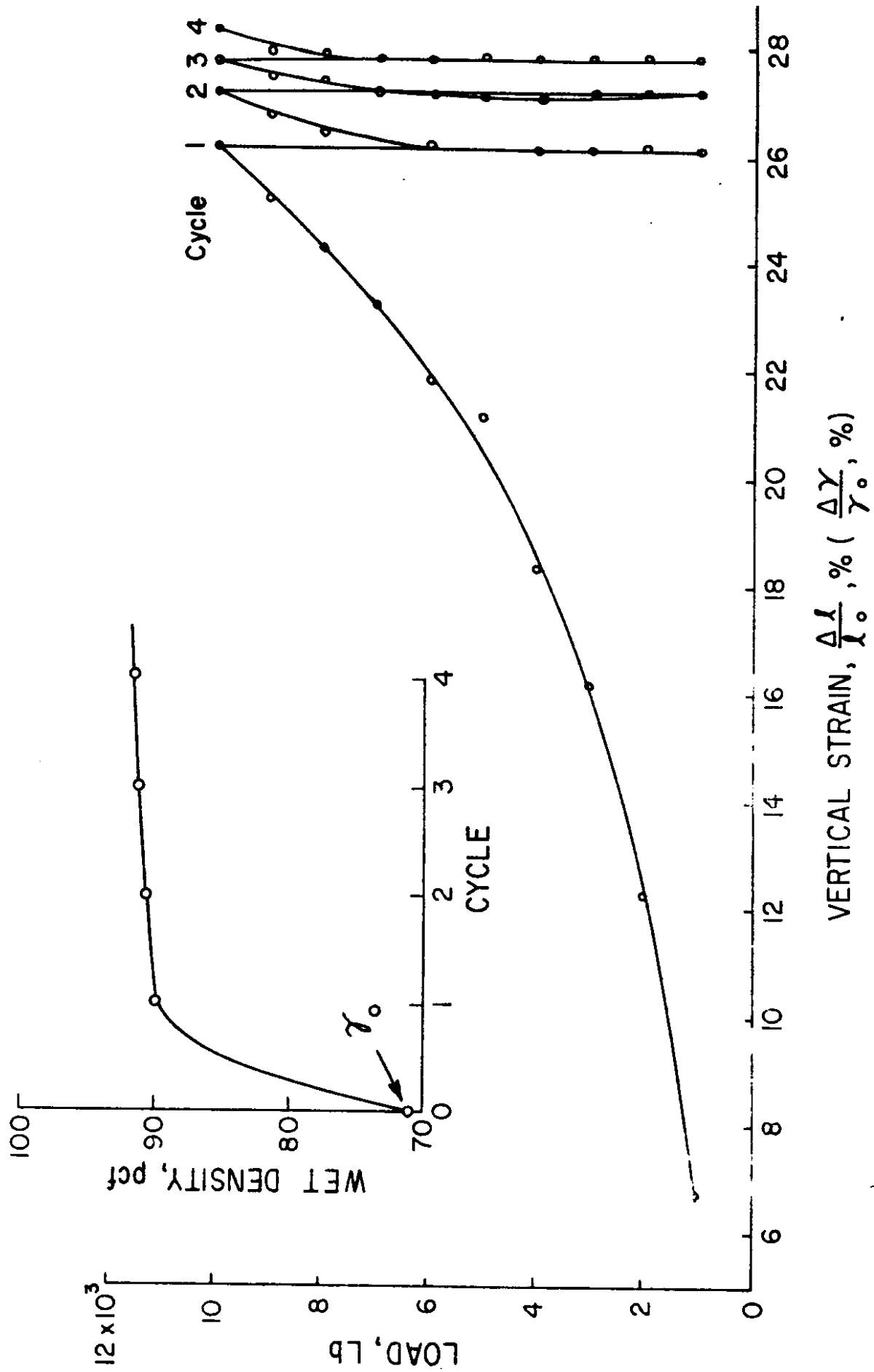

Figure 9-3. Strain Measurements During Compaction of Laterally Confined Soil

The following is a partial list of applications where soil strain measurements are considered useful (some of these are illustrated in Fig. 9-4):

1. Consolidation strains.
2. Backfill strains during wall yielding.
3. Swelling and shrinking volume changes.
4. Compaction during rolling.
5. Strains under pavements due to traffic loads.
6. Strains under structural foundations.
7. Soil arching around buried structures.
8. Shock propagation in soil.
9. Observation of the cratering process.
10. Snow pack changes.

A sensor like this which is sensitive to spacing and changes in spacing has many other useful applications. Examples are (see Fig. 9-5 for some illustrations):

1. Axial and lateral strains in soil strength tests (triaxial tests).
2. Wall movement.
3. Pavement thickness.
4. Strains in concrete structures.
5. Foundation vibrations.
6. Extensometer readout.
7. Soil stress measurement.
8. Load cells construction.
9. Field fabrication of simple devices for measuring loads and deformations.

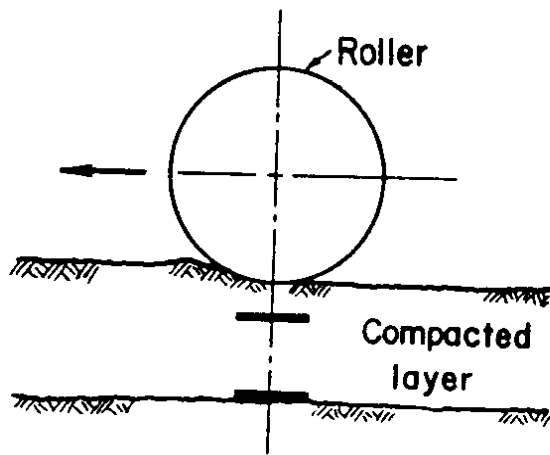

a) Compaction

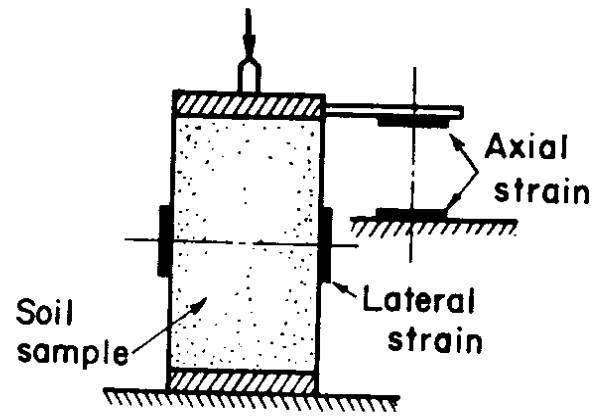

b) Triaxial Tests

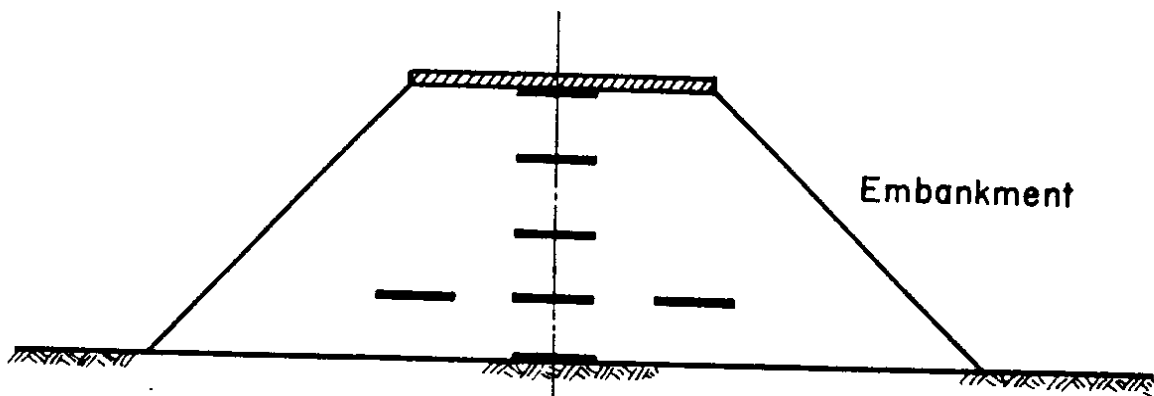

Sensors indicate consolidation, swelling and shrinkage.

c) Embankment Strains

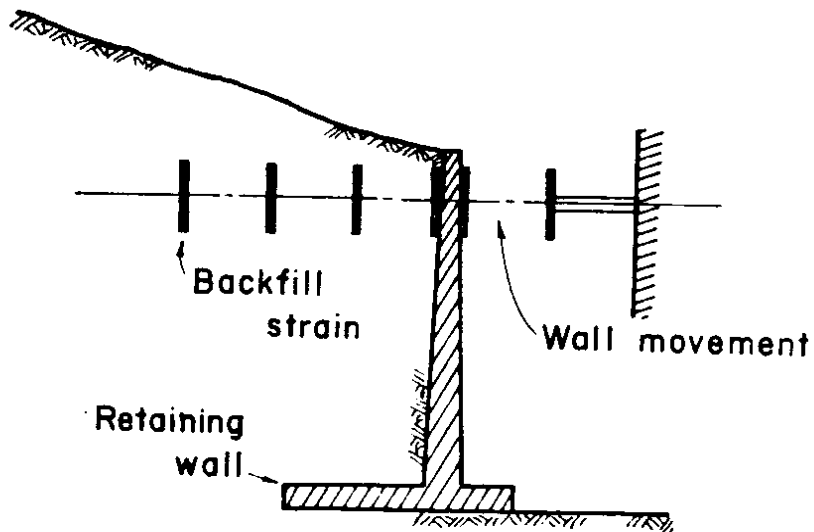

d) Backfill movements

Figure 9-4. Applications for Strain Gage Embedded in Soil

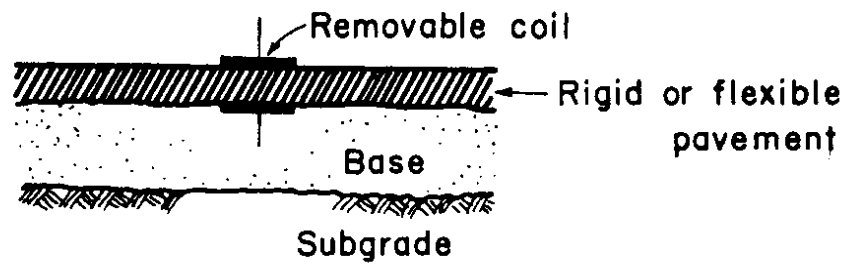

a) Pavement thickness measurement

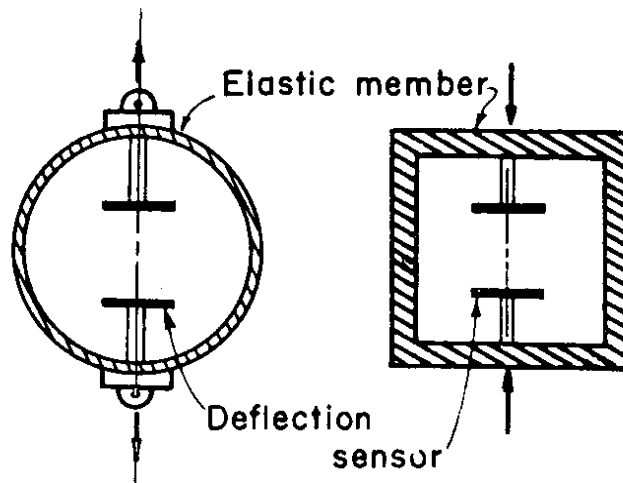

b) Load cells

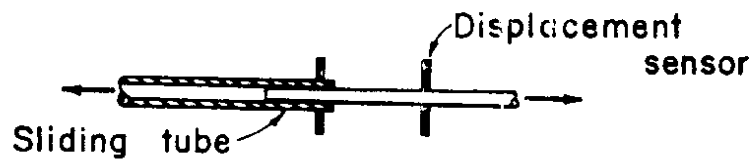

c) Extensometer readout

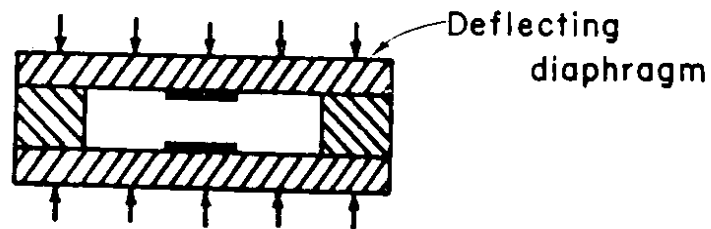

d) Stress or pressure gauge

Figure 9-5. Applications for Strain Gage Other Than in Soil

APPENDIX D

NICOLET INSTRUMENT MANUALS

(Available with Instrumentation Package)

The Nicolet 4094 Digital Oscilloscope



*For those who demand
the ultimate in performance.*

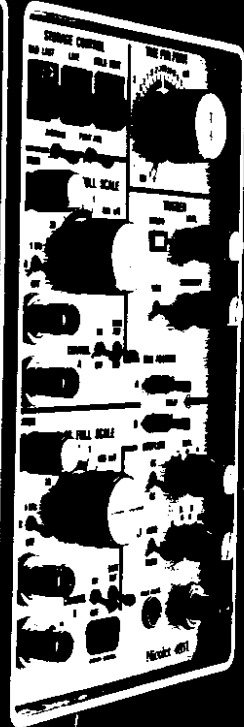
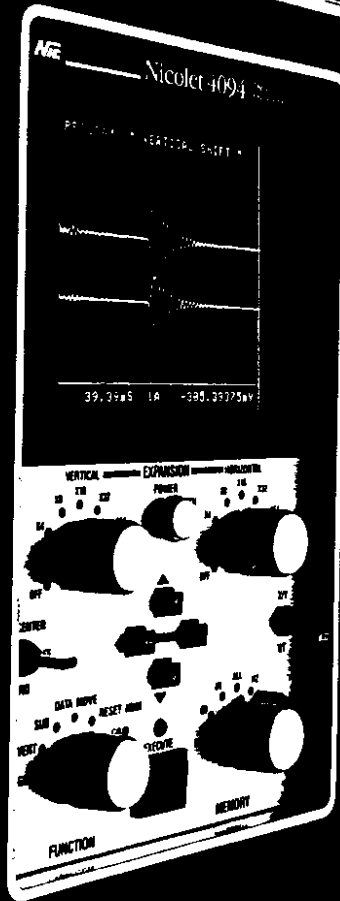
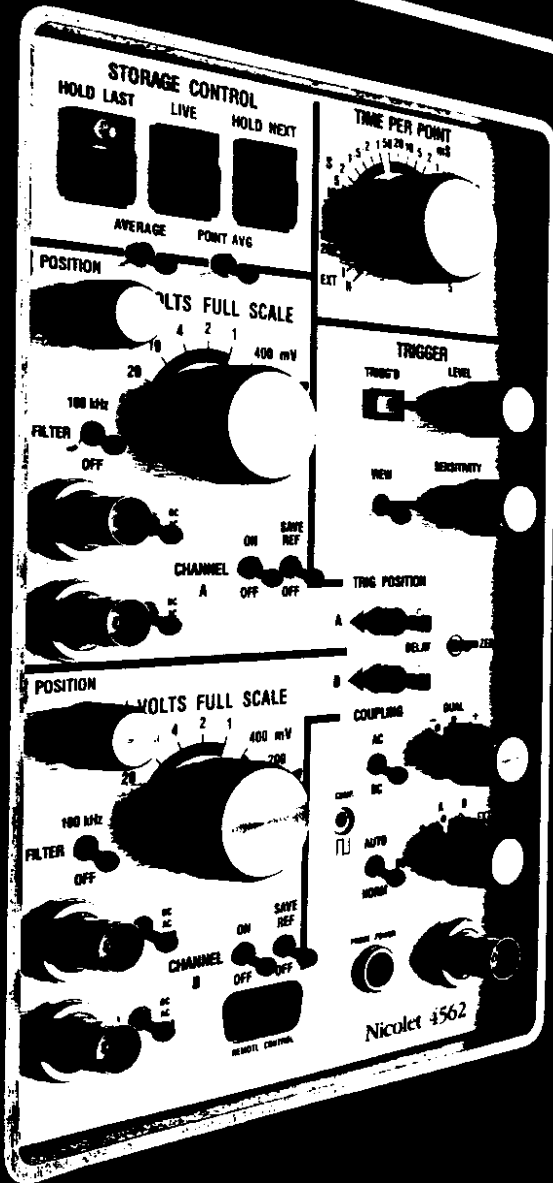

Nicolet 4094: All of our l

Ultra High Resolution and Dynamic Range

The 4094 digital oscilloscope introduces a new standard of digital precision to the measurement of analog signals. With the 15-bit 4851 plug-in, signals with a dynamic range as high as 32,000:1 can be captured and analyzed. Even the faster, 12-bit 4562 plug-in offers a resolution of 4,000:1; about one hundred times better than the best analog oscilloscope! This resolution, coupled with the powerful 16K word, 16-bit mainframe memory and display expansion capability up to X256, allows even the smallest signal features to be examined in detail.

Another benefit of the large data memory is the ability to store and display multiple waveforms. Using the "retain reference" feature, live signals can be compared with stored references. Figure 6, and up to 32 stored waveforms can be displayed simultaneously.

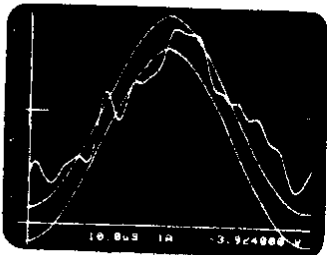

Fig. 6. Comparison of a live signal with two stored references

Four Channel Capability

The 4094 can accept two plug-in units simultaneously. These plug-ins can be slaved together for normal four channel operation, or operated asynchronously on different timebases and with separate triggers; effectively two dual channel oscilloscopes in one!

Pre-Trigger and Post-Trigger Delay

In addition to normal trigger operation, both plug-ins offer pre- and post-trigger sweep delay, independently selectable for each channel. Figure 7. The delay setting is displayed upon the screen and, for pre-trigger operation, the trigger point or "time zero" is visually indicated by the small plug-in controlled "cross-hair" cursor seen in Figure 1.

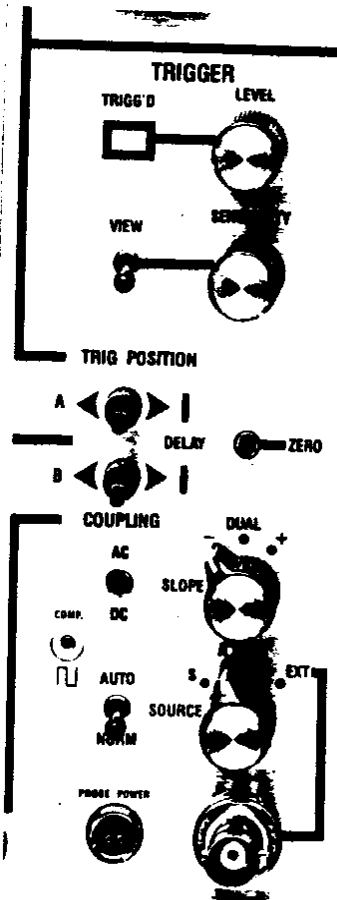

Fig. 7

Sweep and Point Averaging

For repetitive noisy signals, the 4094 offers a normalized sweep averaging mode for signal-to-noise enhancement. Figure 8.

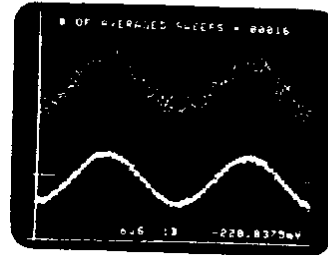

Fig. 8. SIN improvement after 16 sweep averages of noisy signal.

A further unique feature of the 4094 is its ability to reduce noise on slow, single shot, signals via a technique called point averaging. This feature effectively smooths incoming data at sweep speeds slower than 500 microseconds per point by averaging within the assigned time per point. Figure 9 shows noise sampled at 5 milliseconds per point with and without point averaging.

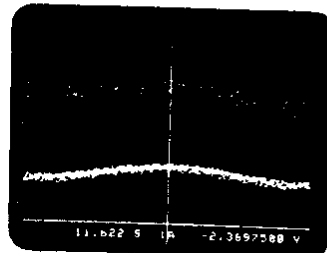

Fig. 9. Effect of point averaging on noise at a 5 millisecond sample rate

Trigger Monitoring

Visual setting of the trigger level and sensitivity is easily accomplished using the "Trigger View" mode, Figure 3. The relative position of the horizontal lines indicates the slope and sensitivity. For unpredictable signals, dual slope triggering is provided. Figure 10.

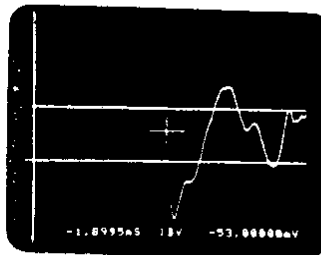

Fig. 10. Trigger View Mode

Cursor Interactive Alphanumeric Display

In both live and stored mode the large mainframe cursor can be used to read the time and voltage co-ordinates of any selected point and to select the required region for expansion. The small "cross-hair" cursor indicates the time and voltage zero point for the waveform intersected by the large cursor, and the channel number is displayed between the numerics, Figure 11.

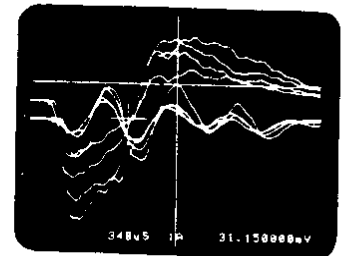

Fig. 11. Cursor-interactive alphanumeric with channel identifier

Relative Measurements

For relative measurements between signal features, a "reset numerics" mode is provided which utilizes both the "cross-hair" and mainframe cursors. In this mode, the letters "RN" are displayed to indicate that numerics are relative, Figure 12.

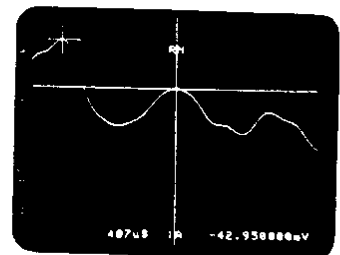

Fig. 12. Delta V, Delta T measurements using large and small cursors.

Grid Display

For photographs of measurements not requiring high accuracy, an electronic

Best ideas in one package.

grid can be displayed, Figure 13. In this mode the numerics indicate time and voltage per grid mark.

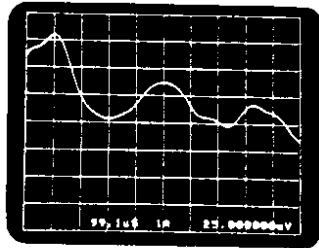

Fig. 13. Selectable grid display.

Disk Storage and Recall

Using the optional built-in or free-standing disk recorders, Figures 14 and 15, data can be stored permanently on 5¼" floppy diskettes. Up to twenty 16K, forty 8K or eighty 4K records can be stored on each diskette, ready for instant recall and display.

An auticycle mode is included which allows completely unattended capture and store of up to 80 individual signals.

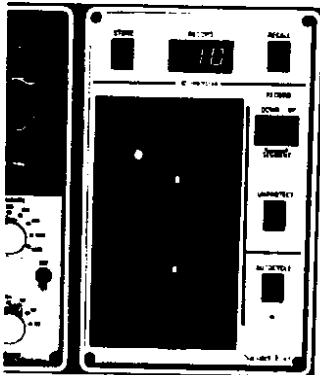

Fig. 14

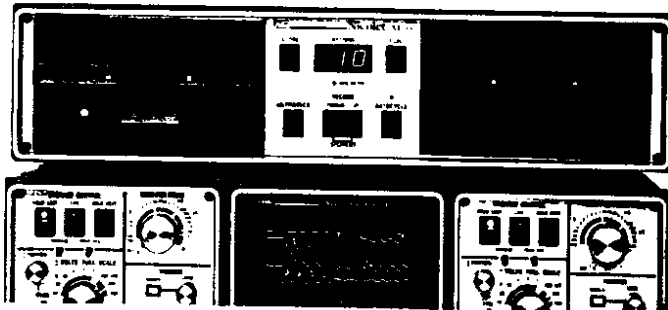

Fig. 15

Pushbutton Data Manipulation

Stored waveforms can be subtracted from, or added to each other, level-shifted for superimposition or inverted via front panel control.

For users with the disk option, further data manipulation functions are available on diskette. These disk programs guide the user with displayed instructions and are executed via a single pushbutton. Figures 16 and 17 show a waveform before

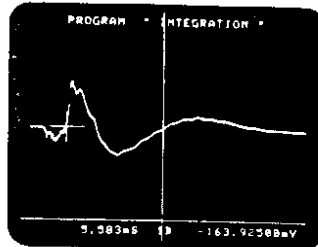

Fig. 16

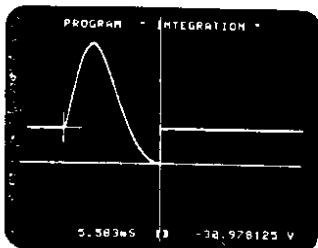

Fig. 17. Integration of cursor-indicated section of waveform in Figure 16.

and after integration of the area between the cursors. Waveforms can even be titled for easy identification on photographs, digital plots, or

when recalled from disk, Figure 18.

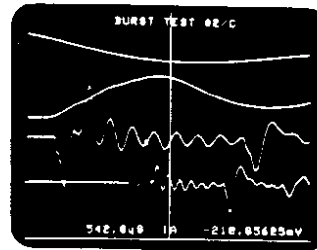

Fig. 18. Waveform identification via user-input title.

A standard set of disk programs is provided with the purchase of the disk recorder option, including:

- Addition and Subtraction
- Multiplication
- Area Calculation
- Integration and Differentiation
- Maximum or Minimum Value
- Horizontal Shift
- RMS Calculation
- Rise Time Calculation
- Three Point Smoothing
- Scaling
- Number of Sweeps (averaging mode)
- Waveform Tiling
- Diskette Copy (Dual Disk Only)

Digital I/O

The 4094 can be easily interfaced to other computers or calculators via the digital I/O option. This

option includes bi-directional IEEE-488 (GPIB) and RS-232C industry standard interfaces, Figure 19.

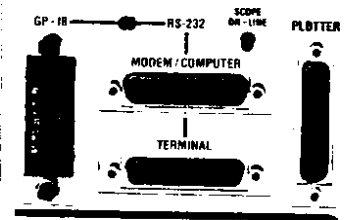

Fig. 19

Using the RS-232C, data is output (or input) in serial binary or ASCII code at speeds up to 19,200 baud. For users requiring higher speed the IEEE-488 interface transfers a full 16K record in as little as 1.5 seconds.

The digital I/O option also includes the disk recorder and digital plotter controller and is a necessary requirement for these options.

Hardcopy Output

All 4094 systems include analog outputs for standard XY or YT pen recorders. For users with the digital I/O option, a digital plotter is available providing report-ready hardcopy recording of up to four waveforms, together with automatic alphanumeric legend, Figure 20.

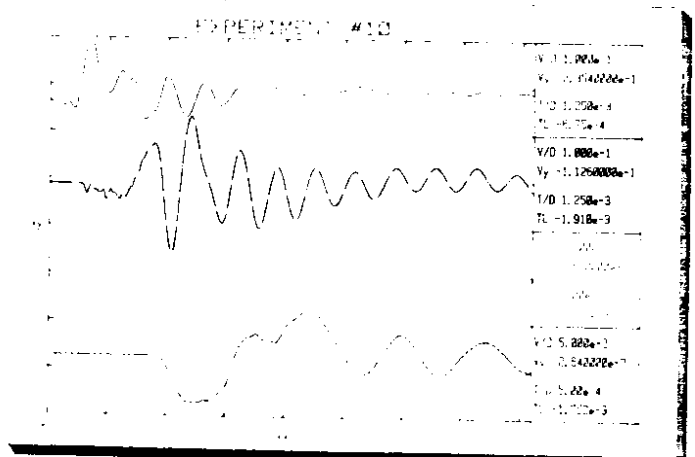

Fig. 20. Report-ready digital plot.



At the touch of a button, capture, store and display up to four signals simultaneously with pre- and post-trigger information,

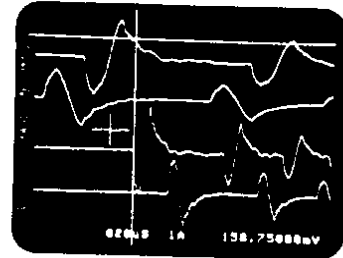

Fig. 1

Figure 1. Extract signals from noise using sweep and point averaging. Expand any selected waveform feature up to X256 on both axes and identify the exact time and voltage coordinate via the alphanumeric display, Figure 2.

Avoid losing data: visually check and measure your trigger level and sensitivity with "trigger view" mode, Figure 3.

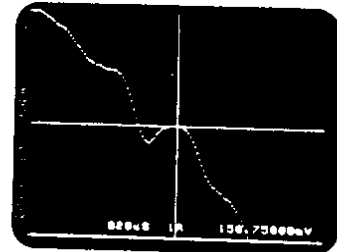

Fig. 2

Compare live waveforms with stored references or display live or stored waveforms as functions of each other in XY mode, Figure 4.

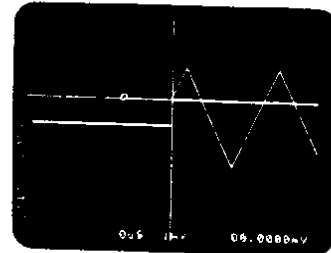

Fig. 3

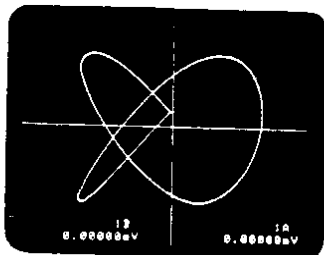

Fig. 4

Obtain hardcopy records on XY, YT or digital plotters or store data permanently on floppy disk ready for instant recall. Manipulate waveforms via built-in or disk-loaded programs and communicate directly with more powerful computers via industry standard interfaces, Figure 5.

These are just some of the features, which, combined with simplicity of operation, make the 4094 a truly outstanding instrument.

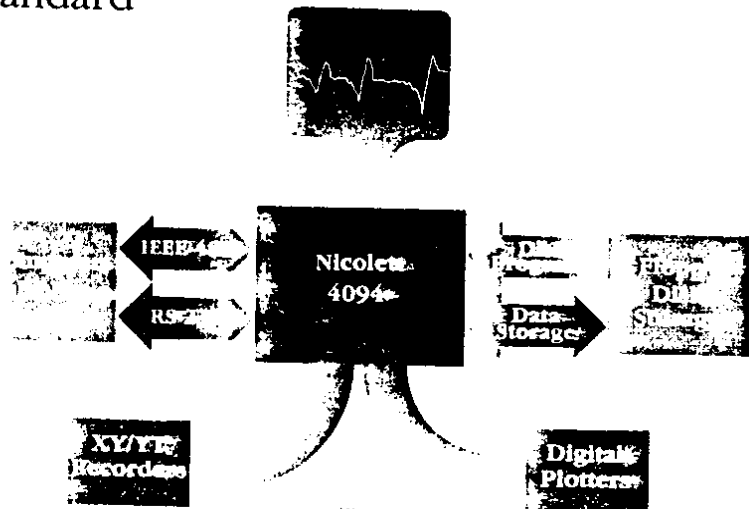

Fig. 5

4094 Specifications

Mainframe

Addressable Subgroups: Halves (8K), quarters (4K)
Data Memory: 31/32 of Memory Size
Storage Capacity: Up to 32 Waveforms
Display: 6-inch, high definition
Expansion: Up to X256, both axes, cursor-interactive
Numerics: Time and voltage plus channel number (YT)
 Voltage and voltage plus channel number (XY)
Numeric Displays (Y or XY): Normal (Absolute numerics)
 Reset Numerics (Relative numerics)
 Grid (Numeric scale per grid mark)
Arithmetic Functions: Subtract, Invert, Data Move
Optional Functions: Disk Expandable

Other Standard Functions:

Autocenter: Automatic lock of cursor to data (unexpanded)
 Automatic data centering (expanded)
Zero (Spring Loaded): Automatic check of analog zero
Pen: Analog output to XY or YT pen recorder
 Output to digital plotter (if connected)

Disk Recorder

Disk Recorder Type: 5 1/4" Floppy, double sided, double density, soft-sectored. Storage capacity/diskette: twenty 16K, forty 8K or eighty 4K records.
Record Identification: 3-digit L.E.D.
Write Protection: Automatic, manual unprotect
Autocycle: Automatic consecutive capture and store of up to 80 records.

Digital I/O

Interfaces Included: IEEE-488 (GPIB), RS-232C, Disk Controller, digital plotter controller.
IEEE-488 (GPIB): Bi-directional up to 20K bytes/second, ASCII or binary
RS-232C: Bi-directional, up to 19,200 baud, ASCII or printable binary
Minimum Transfer Times (16K): GPIB ASCII, 4.5 seconds. GPIB binary, 1.5 seconds. RS-232C ASCII, 55 seconds. RS-232C binary, 18 seconds.

Overall Dimensions

Mainframe:
 43.1 cm (W) × 25.1 cm (H) × 47.2 cm (D)
XF-44 Disk Recorder:
 43.1 cm (W) × 12.1 cm (H) × 47.6 cm (D)

Approximate Weights

Mainframe Only: 30 lbs
4562 Plug-In: 7 lbs
4851 Plug-In: 7 lbs
F-43 Recorder: 3 lbs
XF-44/1 Recorder: 17 lbs
XF-44/2 Recorder: 20 lbs

Power Requirement

120 or 240 VAC, +8% to -20%, Single Phase.

PLUG-INS

	4562	4851
<i>Inputs:</i>	Two, differential	Two, differential
<i>Input Coupling:</i>	AC/DC/GND	AC/DC/GND
<i>Input Impedance:</i>	1MΩ/47pF	1MΩ/47pF
<i>Input Filter (Switchable):</i>	100kHz, RC	1kHz, RC
<i>Input Range (Full Scale):</i>	±100mV to ±40V	±100mV to ±40V
<i>Zero Position Control:</i>	10% 90% FS	10% 90% FS
<i>Safe Overload:</i>		
±10V to ±40V Range:	400V	150V
±1V to ±4V Range:	300V	40V
±100mV to ±400mV Range:	300V	40V
<i>Analog Bandwidth:</i>		
±1V to ±40V Range:	1MHz	50kHz
±100mV to ±400mV Range:	400kHz	50kHz
<i>Common Mode Rejection Ratio:</i>	90dB	90dB
<i>Common Mode Voltage Range:</i>	200% FS	200% FS
<i>Maximum Digitizing Rate:</i>	2MHz (500ns/pt)	100kHz (10μs/pt)
<i>Minimum Digitizing Rate:</i>	200sec/pt	200sec/pt
<i>Vertical Resolution:</i>	12-bits (0.025%)	15-bits (0.005%)
<i>Horizontal Resolution (Max):</i>	15,872:1	15,872:1
<i>Buffer Memory Size:</i>	16K × 16 bits	16K × 16 bits
<i>Accuracy:</i>	0.2% FS	0.15% FS
<i>Linearity:</i>	0.1% FS	0.08% FS
<i>Noise, RMS:</i>	0.02% FS	0.007% FS
<i>Sample Time Uncertainty:</i>	±1ns	±1ns
<i>Single Sweep Drift (°C):</i>	0.04% FS	0.04% FS
<i>Sweep to Sweep Drift:</i>	Negligible	Negligible
<i>Ground Reference Accuracy:</i>	0.1% FS	0.05% FS
<i>Trigger Range, External:</i>	±10V	±10V
<i>Trigger Sensitivity, External:</i>	0.5V	0.5V
<i>Trigger Range, Internal:</i>	80% FS	80% FS
<i>Trigger Sensitivity, Internal:</i>	2% FS	2% FS
<i>Trigger Modes:</i>	Auto/Normal	Auto/Normal
<i>Max Pre-Trigger Delay Range:</i>	99.9% sweep time	99.9% sweep time
<i>Max Post-Trigger Delay Range:</i>	2 ²⁴ × time/pt	2 ²⁴ × time/pt

Other Features:

- The ability to retain a reference signal on each channel.
- Sweep averaging at all speeds.
- Point averaging (inter-sample averaging) at speeds slower than 500μs/pt.
- Trigger view mode for trigger set-up.



**NICOLET
 INSTRUMENT
 CORPORATION**
 OSCILLOSCOPE DIVISION

5225 Verona Road/Madison, WI 53711/608/271-3333