



Transmittal Number PT 06-040	Date August 2006
Publication Distribution To: All holders of the Sign Fabrication Manual	
Publication Title Sign Fabrication Manual	Publication Number M 55-05
Originating Organization Maintenance and Operations- Traffic Operations Office	

Remarks and Instructions:

Instructions:

Following is a list of revised signs included in this transmittal. **Signs shown in bold text are new additions to the manual.** Revision dates are shown just below the sign number at the top of the page. Signs that have not been revised and that are on the opposite side of the revised page, are included and indicated by (). Please remove the obsolete pages and insert pages as follows.

FORWARD

NUMERICAL INDEX – All pages.

ALPHABETICAL INDEX – All pages.

D-SERIES: D1-601, D1-701, D1-801, (D3-101), D3-102, (D3-103), D3-104, **D3-2, D3-2A**, D3-201, D3-301, D3-302, D3-401, (D4-1), (D4-2), (D4-301), D4-401, (D5-101), D5-102), (D5-103), D5-201, (D5-202), (D5-203), D5-204, (D5-301), (D5-901), **D6-1, D6-2, D6-3**, D5-902 through **D5-908 & D7-401** through **D7-1001**, D7-1101 through D7-2204, (D7-7701), D8-301, (D9-1), **D9-11A, D9-11B**, (D9-13), **D9-13A, D9-13B, D9-13C**, (D9-1301), **D9-14**, (D9-15), D9-1601, (D10-1 through D10-3), D10-101 through D10-301, D13-1, **D13-2, D13-3**.

E-SERIES: E1-1, (E1-4), (E2-1A), E3-101, (E4-301), E4-501, (E5-1), E5-1A, **E5-3, E5-4**, E6-101, E6-2, E7-1, E8-1, E8-2, E9-1, E11-1, (E12-101, -201), (E13-1), E13-2.

G-SERIES: G28-201

I-SERIES: 18-301, (18-401), I8-708, (I8-709), I25-101, (I25-102), I25-201, I35-101, (I35-102).

L-SERIES: LG-M1, **LG-M1A**, (LG-M2), LG-M3, **LG-M3A**, (LG-M4), LG-M5, **LG-M5A**, (LG-M6), (LG-M7), (LG-M8), LG-M9, **LG-M9A**, (LG-M10), LG-R1, (LG-R2), (LG-R3), **LG-R4**.

M-SERIES: (M1-3), M1-4, M1-601, M1-602, (M1-7), M1-701, (M1-8), **M4-7A & B**, (M4-8), M4-9L/R, **M4-9A, M4-9B, M4-9C**, (M4-10L&R), M5-1 through M5-2B, (M6-1 through M6-2BR), M8-101, M8-201.

R-SERIES: **R1-5L&R, R1-6A,** (R2-4A), (R2-501), R3-1102L&R, **R3-1103L&R,** R3-1104L&R, (R3-14), R3-1401, R3-17, **R3-17B, R3-17C, R3-18,** R4-7, (R4-901), **R4-10, R5-1B,** R6-1L&R, (R6-2L&R), **R7-203,** R7-9, (R7-9A), **R8-3C, R8-3D,** (R9-3B L&R), **R9-3C,** (R9-4), (R10-6A), R10-601L&R, (R10-8), (R10-10L&R), **R10-11,** (R10-11A), (R10-11B), **R10-15, R10-16, R10-17A, R10-18, R10-19, R10-20A, R10-20B, R10-21, R10-22,** (R12-5), R12-501, (R14-1), R14-2, R14-3, (R14-4).

S-SERIES: **S4-5 & S4-5A.**

W-SERIES: **W1-10L&R, W1-15, W3-5,** (W3-501), (W4-1L&R), W4-2L&R, **W4-5, W4-6,** (W5-3), W7-4, **W7-4A, W7-4B, W4-7C through W7-4E,** (W8-3), (W10-1), **W10-1A,** (W10-101), **W10-12, W10-13,** W12-301, (W12-302L&R), (W16-101 & W16-102), (W16-5PR through W16-6PL), (W16-7PL&R), (W16-9P), **W16-10,** W21-1701.

APPENDICES: A-7, (A-8), **B-1 (for W7 – 4B),** B-4A, (B-4B), (B-6A), **B-7, D-26A.**

Following is a list of signs that can be removed entirely from the Manual. Please remove the obsolete pages as follows:

L-SERIES: Business Logos.

R-SERIES: R2-5A, R2-5B, R2-5C, R3-16, R3-16A, R3-17A, R10-11C, R10-11D.

W-SERIES: W5-2A, W8-3A.

Distributed By Directional Documents and Engineering Publications	Phone Number (360) 705-7430 FAX: 705-6861	Signature <i>Stephanie Williams</i>
---	---	--

Foreword

This edition of the Sign Fabrication Manual has been prepared to assist sign fabricators, both public and private, in maintaining a uniform appearance of official highway signs.

The highway signs illustrated herein represent the signs currently in use in Washington State. Included are the signs contained in the Federal Standard Highway Signs Book and additional signs approved for use within the state. A section has also been included, for use in conjunction with the Manual on Uniform Traffic Control Devices, to assist designers with sign layouts.

Warning signs that are utilized for temporary traffic control shall have an orange (retroreflective) background with black (non-reflective) legend, borders, and/or symbols.

In this edition, most signs are drawn without horizontal dimensioning for layouts. Fabricators are to optically center layouts to achieve a balanced sign.

Letter fonts and colors are to be in accordance with the Manual on Uniform Traffic Control Devices. Standard Color Tolerance Charts are \$60 per color chart; or \$300 for a set of 6 color charts. Contact: Hale Color Charts, Inc., 3709 Ocean View Avenue, Los Angeles, CA 90066. Telephone: 800-777-1225. On the Web at: www.halecolorcharts.com.

Updating the manual is a continuing process and revisions are issued periodically. Address orders, questions, and suggestions to the Engineering Publications Branch.

D SERIES

- D1-101 1 DESTINATION W/ARROW*
 - D1-201 2 DESTINATIONS W/ARROWS*
 - D1-301 3 DESTINATIONS W/ARROWS*
 - D1-401 ADVANCE DESTINATION*
 - D1-501 ADVANCE DESTINATION W/ROUTE MARKER*
 - D1-601 MULTILANE DESTINATION W/ARROW*
 - D1-602 MULTILANE DESTINATIONS W/ARROWS*
 - D1-603 MULTILANE DESTINATIONS W/ARROWS*
 - D1-701 DIRECTIONAL W/ROUTE MARKER*
 - D1-801 APPROACH DIRECTIONAL SIGN - 2 DESTINATIONS*
 - D1-901 APPROACH DIRECTIONAL SIGN - 1 DESTINATION*
 - D3-101 STREET NAME SIGN*
 - D3-102 CROSSROADS NAME SIGN
 - D3-104 PRIVATE ROAD NAME SIGN
 - D3-2 ADVANCE STREET NAME SIGN W/ARROW
 - D3-2A ADVANCE STREET NAME SIGN NEXT INTERSECTION
 - D3-201 CROSSROADS NAME SIGN*
 - D3-301 CROSSROADS NAME SIGN*
 - D3-302 CROSSROADS NAME SIGN W/CHEVRON*
 - D3-401 STREET NAME SIGN W/GEORGE SHIELD*
 - D4-1 URBAN PUBLIC PARKING SIGN
 - D4-2 PARK & RIDE*
 - D4-301 PARK & RIDE _____*
 - D4-401 REST AREA PARKING*
 - D5-101 REST AREA _____ MILES
 - D5-102 NEXT REST AREA _____ MILES
 - D5-103 REST AREA NEXT RIGHT
 - D5-201 REST AREA (ARROW _____ DEGREES) (MAJOR)
 - D5-202 REST AREA VISITOR INFORMATION CENTER _____ MILES
 - D5-203 REST AREA VISITOR INFORMATION CENTER NEXT RIGHT
 - D5-204 REST AREA VISITOR INFO CENTER (ARROW _____ DEGREES)
 - D5-301 TIRED? REST AREA _____ MILES
 - D5-601 REST AREA ADVANCE (MINOR)
 - D5-602 _____ MILE
 - D5-701 REST AREA (ARROW _____ DEGREES) (MINOR)
 - D5-801 PET AREA DIRECTIONAL
 - D5-901 PET AREA KEEP PETS ON LEASH
 - D5-902 SYMBOL - RANGER STATION
 - D5-903 SYMBOL - LIGHTHOUSE
 - D5-904 SYMBOL - INFORMATION
 - D5-905 SYMBOL - VIEWPOINT
 - D5-906 SYMBOL - PET AREA KEEP PETS ON LEASH
 - D5-907 SYMBOL - WATCHABLE WILDLIFE (BINOCULAR)
 - D5-908 SYMBOL - REST ROOM
 - D6-1 SCENIC AREA W/ARROW
 - D6-2 SCENIC AREA ADVANCE SIGN
 - D6-3 SCENIC AREA EXIT DIRECTION
- * denotes variable message sign

D7-101	RECREATIONAL AREA ADVANCE SIGN	
D7-201	RECREATIONAL AREA DIRECTIONAL SIGN	
D7-301	MOUNTAIN PEAK - VIEW STRAIGHT AHEAD	
D7-301L	MOUNTAIN PEAK - VIEW LEFT	
D7-301R	MOUNTAIN PEAK - VIEW RIGHT	
D7-301P	IN THE DISTANCE PLAQUE	
D7-401	SYMBOL - BICYCLE TRAIL	
D7-501	SYMBOL - TRAIL	
D7-601	SYMBOL - BRIDLE TRAIL	
D7-701	SYMBOL - GOLFING	
D7-801	SYMBOL - CLIMBING	
D7-901	SYMBOL - TRAIL (INTERPRETIVE PED)	
D7-1000	MARINE RECREATION AREA	
D7-1001	SYMBOL - BOATING	
D7-1101	SYMBOL - BOAT LAUNCH	
D7-1201	SYMBOL - BOAT MOORAGE	
D7-1301	SYMBOL - FISHING	
D7-1401	SYMBOL - SWIMMING	
D7-1402	BEACH	
D7-1501	SYMBOL - WATER SKIING	
D7-1601	SYMBOL - CANOEING	
D7-1701	SYMBOL - ROWBOATING	
D7-2001	SYMBOL - SNOW SKIING	
D7-2002	SYMBOL - CROSS COUNTRY SKIING	
D7-2101	SYMBOL - SNOWMOBILE AREA	
D7-2103	SYMBOL - WINTER SPORTS	
D7-2104	SYMBOL - SNOWSHOEING	
D7-2201	SYMBOL - PICNICKING	
D7-2202	NO CAMPING	
D7-2203	SYMBOL - PLAYGROUND	
D7-2204	SYMBOL - CAMPFIRE	
D7-7701	REC AREA NEXT RIGHT	
D8-1	WEIGH STATION ____ MILE	
D8-101	EMERGENCY CALL BOX	
D8-201	WEIGH STATION RIGHT LANE	
D8-202	OPEN - CLOSED PANEL	
D8-301	WEIGH STATION EXIT (ARROW _____ DEGREES)	
D9-1	PHONE SYMBOL (Informational)	
D9-1A	SYMBOL PHONE (ARROW _____ DEGREES)	
D9-1B	SYMBOL ADVANCE PHONE _____ MILE	
D9-101	FOOD - PHONE - GAS - LODGING, ETC.*	
D9-102	FOOD - PHONE - GAS - LODGING NEXT RIGHT*	
D9-103	FOOD - GAS - LODGING NEXT RIGHT*	
D9-1	PHONE SYMBOL (Recreational)	
D9-3	SYMBOL - TENT CAMPING	

* denotes variable message sign

D9-3A	SYMBOL - TRAILER CAMPING	
D9-3B	SYMBOL - TRAILER AND TENT CAMPING	
D9-4	SYMBOL - RESTROOM MEN	
D9-5	SYMBOL - RESTROOM WOMEN	
D9-6	SYMBOL - HANDICAPPED	
D9-7	SYMBOL - RESTROOM WOMEN AND MEN	
D9-8	SYMBOL - FOOD	
D9-9	SYMBOL - LODGING	
D9-10	SYMBOL - SHOWERS	
D9-11	SYMBOL - FUEL, GASOLINE	
D9-11A	SYMBOL - FUEL, COMPRESSED NATURAL GAS	
D9-11B	SYMBOL - FUEL, ETHANOL	
D9-1101	SYMBOL - FUEL, DIESEL	
D9-12	SYMBOL - RECREATIONAL VEHICLE SANITARY STATION	
D9-2	SYMBOL - HOSPITAL	
D9-301	RV PARK SIGN	
D9-401	ARROW SIGN	
D9-501	DIRECTIONAL ARROW DETAILS (HORIZONTAL)	
D9-502	DIRECTIONAL ARROW DETAILS (VERTICAL)	
D9-13	SYMBOL - EMERGENCY MEDICAL SERVICES	
D9-13A	HOSPITAL	
D9-13B	AMBULANCE STATION	
D9-13C	EMERGENCY MEDICAL CARE	
D9-1301	SYMBOL - QUESTION MARK	
D9-14	POLICE	
D9-15	SYMBOL - LP GAS	
D9-1601	NEXT SERVICES _____ MILES	
D10-1	MILE _____ (SINGLE FACED)	
D10-2	MILE _____ (SINGLE FACED)	
D10-3	MILE _____ (SINGLE FACED)	
D10-101	MILE _____ (BACK TO BACK)	
D10-201	MILE _____ (BACK TO BACK)	
D10-301	MILE _____ (BACK TO BACK)	
D10-401	BACK EQ. PLAQUE	
D10-501	SPUR ROUTE PLAQUE	
D11-1	BIKE ROUTE	
D12-201	CAR POOL INFO _____	
D12-202	CAR POOL INFO W/SYMBOL _____	
D13-1	FREE COFFEE	
D13-2	CROSSOVER W/ARROW	
D13-3	CROSSOVER 1/4 MILE	

E SERIES

E1-1	ADVANCE GUIDE SIGN*	
E1-4	DIAGRAMMATIC*	
E1-5	EXIT PANEL*	
E2-1	NEXT EXIT _____ MILES	

* denotes variable message sign

E2-1A	NEXT EXIT _____ MILES
E3-101	DOUBLE EXIT OR NEXT RIGHT SECOND LEFT*
E4-301	NEXT RIGHT GUIDE SIGN*
E4-501	EXIT ONLY GUIDE SIGN W/ARROW*
E5-1	EXIT (ARROW _____ DEGREES)
E5-1A	EXIT GORE SIGN WITH EXIT NUMBER AND ARROW*
E5-2	EXIT ONLY
E5-2A	EXIT OPEN
E5-2B	EXIT CLOSED
E5-3	EXIT NUMBER PLAQUE FOR EXIT GORE SIGN
E5-4	ADVISORY SPEED PLAQUE FOR EXIT GORE SIGN
E6-101	EXIT DIRECTION*
E6-2	PULL THRU SIGN (OVERHEAD)*
E7-1	MILEAGE SIGN*
E8-1	INTERCHANGE SEQUENCE SIGN*
E8-2	CITY INTERCHANGE SEQUENCE*
E9-1	CITY NEXT _____ EXITS*
E11-1	EXIT ONLY PANELS
E12-101	HIGHWAY ENTRANCE
E12-201	FREEWAY ENTRANCE
E13-1	PARK AND RIDE NEXT RIGHT*
E13-2	PARK AND RIDE W/EXIT NUMBER*

G-SERIES

G20-1	ROAD WORK NEXT _____ MILES
G20-2A	END ROAD WORK
G20-4	PILOT CAR FOLLOW ME
G20-601	END LANE CLOSURE
G24-101	USE ALL LANES
G24-201	USE LEFT LANE
G24-301	USE RIGHT LANE
G24-501	FOR PROJECT INFORMATION _____
G28-101	WORK ZONE AHEAD; GIVE'EM A BRAKE
G28-201	THANK YOU – WSDOT & (CONTRACTOR'S NAME)

I SERIES

I1-1	SIGNALS SET FOR _____ MPH
I1-2	USE YOUR ASHTRAY
I1-201	SYMBOL - FOREST FIRE PREVENTION
I1-301	VEGETATION MANAGEMENT APPLICATION
I2-101	WELCOME TO WASHINGTON
I2-201	COUNTY ENTRANCE SIGN*
I2-301	CITY ENTRANCE SIGN*
I2-401	RANGE AREA WATCH OUT FOR LIVESTOCK
I2-501	LEAVING RANGE AREA
I2-601	ENTERING LIMITED ACCESS AREA
I2-701	LEAVING LIMITED ACCESS AREA

* denotes variable message sign

- I3-101 STREAM NAME SIGN*
- I3-201 SUMMIT ELEVATION SIGN*
- I4-301 LEWIS-CLARK TRAIL MARKER
- I4-401 SCENIC AND RECREATIONAL HIGHWAY MARKER
- I5-103 HERITAGE MARKER _____ MILE
- I5-104 HERITAGE MARKER W/ARROW
- I5-5 AIRPORT (SYMBOL)
- I5-6 BUS STATION (SYMBOL)
- I5-7 TRAIN STATION (SYMBOL)
- I5-801 FERRY (SYMBOL/CAR BOARDING FERRY)
- I5-801A FERRY (SYMBOL/FERRY)
- I6-101 DEPOSIT LITTER _____ MILE(S)
- I6-102 LITTER AND IT WILL HURT
- I6-201 LITTER SYMBOL SIGN
- I6-301 THROWING AWAY BURNING MATERIAL PROHIBITED
- I6-801 AUTOMOBILE LITTER ONLY
- I6-901 ADOPT-A-HIGHWAY (SMALL)
- I6-902 ADOPT-A-HIGHWAY "GROUP'S NAME (HERE)"(SMALL)
ADOPT-A-HIGHWAY "THIS AREA AVAILABLE"/PHONE NUMBER
(SMALL)
- I6-903 (SMALL)
- I6-901A ADOPT-A-HIGHWAY (LARGE)
- I6-902A ADOPT-A-HIGHWAY "GROUP'S NAME (HERE)"(LARGE)
ADOPT-A-HIGHWAY "THIS AREA AVAILABLE"/PHONE NUMBER
(LARGE)
- I6-903A (LARGE)
- I6-904 ADOPT-A-HIGHWAY LITTER CONTROL
- I6-905A ADOPT-A-HIGHWAY MEDIAN NEXT _____ MILES
- I7-301 BRIDGE NUMBER
- I7-401 FIRE HYDRANT MARKER
- I7-501 TURN ON LIGHTS
- I7-601 LIGHTS ?
- I7-7 CAUTION-NO WARNING SIGNS
- I7-701 PRIMITIVE ROAD NO WARNING SIGNS
- I7-702 NEXT _____ MILES
- I7-901 HITCHHIKING PERMITTED
- I8-101 SLOW VEHICLES USE TURNOUTS NEXT _____ MILES
- I8-201 DELAY OF 5 VEHICLES ILLEGAL MUST USE TURNOUTS
- I8-301 SLOW VEHICLE TURNOUT (ARROW _____ DEGREES)
- I8-401 SLOW VEHICLE TURNOUT _____
- I8-501 SLOW VEHICLES MAY USE SHOULDER
- I8-601 END SHOULDER DRIVING
- I8-701 DAYLIGHT HOURS ONLY
- I8-702 PLEASE LIMIT YOUR STAY TO 8 HOURS NO TENTS OR CAMPS
- I8-703 NOTICE-PARKING/COMMUTERS ONLY
- I8-704 COMMERCIAL VEHICLE USE PROHIBITED
- I8-705 LEAN WATER ARROW DIRECTIONAL
- I8-706 CLEAN WATER - USE FOR FILLING DOMESTIC TANKS ONLY
- I8-708 DUMP STATION INSTRUCTIONS
- I8-709 WATER UNSAFE TO DRINK

* denotes variable message sign

I8-801	MOWING TEST AREA	
I8-804	ENTERING FIRE DISTRICT NO. _____	
I8-901	STATE LAW ALL VEHICLES MUST KEEP TO RIGHT EXCEPT TO PASS	
I8-1001	STATE LAW-MOTORCYCLISTS MUST WEAR HELMETS	
I9-101	PLAYGROUND	
I20-101	REPORT DRUNK DRIVING	
I20-201	PLEASE DON'T DRINK AND DRIVE	
I20-203	IN MEMORY OF _____	
I20-204	SPONSORED BY THE _____ FAMILY	
I20-301	TRAFFIC FINES DOUBLE IN WORK ZONES	
I25-101	TSUNAMI EVACUATION ROUTE	
I25-102	TSUNAMI WARNING	
I25-201	VOLCANO EVACUATION ROUTE	
I30-101	SPEEDOMETER CHECK SECTION AHEAD	
I30-301	END CHECK MILE _____	
I30-301A	BEGIN CHECK MILE _____	
I30-401	MILE _____	
	TRAVELER INFO TUNE _____ AM TRAFFIC ADVISORY WHEN	
I35-101	FLASHING	
I35-102	TRAVELER INFO DIAL 511	

L SERIES

LG-C1	GAS, FOOD, LODGING NEXT RIGHT/LEFT (CONVENTIONAL ROADS)*	
LG-C2	TOURIST ACTIVITIES (CONVENTIONAL ROADS)*	
LG-C3	RECREATION (CONVENTIONAL ROADS)*	
LG-M1	GAS EXIT XXX, HORIZONTAL PANEL (FREEWAY)*	
LG-M1A	GAS EXIT XXX, VERTICAL PANEL (FREEWAY)*	
LG-M2	GAS (FREEWAY DOUBLE EXITS)*	
LG-M3	FOOD EXIT XXX (FREEWAY)*	
LG-M3A	FOOD EXIT XXX, VERTICAL PANEL (FREEWAY)*	
LG-M4	FOOD (FREEWAY DOUBLE EXIT)*	
LG-M5	LODGING EXIT XXX (FREEWAY)*	
LG-M5A	LODGING EXIT XXX, VERTICAL PANEL (FREEWAY)*	
LG-M6	LODGING (FREEWAY DOUBLE EXIT)*	
LG-M7	RECREATION NEXT RIGHT (FREEWAY)*	
LG-M8	RECREATION (FREEWAY DOUBLE EXIT)*	
LG-M9	TOURIST ACTIVITIES EXIT XXX (FREEWAY)*	
LG-M9A	TOURIST ACTIVITIES EXIT XXX, VERTICAL PANEL (FREEWAY)*	
LG-M10	TOURIST ACTIVITIES (FREEWAY DOUBLE EXIT)*	
LG-R1	GAS FOOD LODGING (RAMPS)*	
LG-R2	RECREATION (RAMPS)*	
LG-R3	TOURIST ACTIVITIES (RAMP)*	
LG-R4	GAS, FOOD (RAMPS WITH ROUNDABOUTS)*	

* denotes variable message sign

M SERIES

M1-1	INTERSTATE _____	
M1-2	INTERSTATE BUSINESS LOOP _____	
M1-3	INTERSTATE BUSINESS SPUR _____	
M1-4	U.S. _____	
M1-4A	U.S. _____ (GUIDE SIGN USE)	
M1-401	U.S. _____ (DIRECTIONAL)	
M1-601	STATE ROUTE _____	
M1-602	STATE ROUTE _____ (GUIDE SIGN USE)	
M1-7	_____ NATIONAL FOREST (FOREST SERVICE ROUTE MARKER)	
M1-701	STATE ROUTE _____ (DIRECTIONAL)	
M1-8	BIKE SYMBOL ____ (BICYCLE ROUTE MARKER)	
M1-9	_____ BIKE SYMBOL (INTERSTATE BIKE ROUTE MARKER)	
M2-1	JCT	
M2-2	JUNCTION _____	
M3-1	NORTH	
M3-1B	NORTH	
M3-2	EAST	
M3-2B	EAST	
M3-3	SOUTH	
M3-3B	SOUTH	
M3-4	WEST	
M3-4B	WEST	
M4-1	ALTERNATE PLAQUE	
M4-101	ALT PLAQUE	
M4-2	BYPASS	
M4-3	BUSINESS	
M4-4	TRUCK	
M4-5	TO	
M4-5B	TO	
M4-6	END	
M4-7	TEMPORARY	
M4-7A	TEMPORARY, BLACK ON WHITE	
M4-7B	TEMPORARY, WHITE ON BLUE	
M4-8	DETOUR	
M4-9L/R	LEFT/RIGHT DETOUR (ARROW _____ DEGREES)	
M4-9A	BICYCLE/PEDESTRIAN DETOUR	
M4-9B	PEDESTRIAN DETOUR	
M4-9C	BICYCLE DETOUR	
M4-10	L/R LEFT/RIGHT DETOUR (ARROW)	
M4-11	BEGIN	
M4-12	END	
M4-13	TO	
M4-1101	BEGIN (BICYCLE ROUTE)	
M4-1201	END (BICYCLE ROUTE)	
M4-1301	TO (BICYCLE ROUTE)	
M5-1	ADVANCE TURN ARROW 90 DEGREES	

* denotes variable message sign

M5-1B	ADVANCE TURN ARROW 90 DEGREES	
M5-2	ADVANCE TURN ARROW 45 DEGREES	
M5-2B	ADVANCE TURN ARROW 45 DEGREES	
M6-1	DIRECTIONAL ARROW 90 DEGREE	
M6-1B	DIRECTIONAL ARROW 90 DEGREE	
M6-2	DIRECTIONAL ARROW 45 DEGREES	
M6-2B	DIRECTIONAL ARROW 45 DEGREES	
M6-3	DIRECTIONAL ARROW 360 DEGREES	
M6-3B	DIRECTIONAL ARROW 360 DEGREES	
M6-4	DIRECTIONAL ARROW 2 HEADS 90 DEGREES/270 DEGREES	
M6-4B	DIRECTIONAL ARROW 2 HEADS 90 DEGREES/270 DEGREES	
M6-5	DIRECTIONAL ARROW 2 HEADS 45 DEGREES/225 DEGREES	
M6-5B	DIRECTIONAL ARROW 2 HEADS 45 DEGREES/225 DEGREES	
M6-6	DIRECTIONAL ARROW 2 HEADS 360 DEGREES/90 DEGREES	
M6-6B	DIRECTIONAL ARROW 2 HEADS 360 DEGREES/90 DEGREES	
M6-7	DIRECTIONAL ARROW 2 HEADS 360 DEGREES/45 DEGREES	
M6-7B	DIRECTIONAL ARROW 2 HEADS 360 DEGREES/45 DEGREES	
M7-1	BICYCLE DIRECTIONAL ARROW 90 DEGREES	
M7-2	BICYCLE DIRECTIONAL ARROW 360 DEGREES	
M7-3	BICYCLE DIRECTIONAL ARROW 2 HEADS 45 DEGREES/225 DEGREES	
M7-4	BICYCLE DIRECTIONAL ARROW 45 DEGREES	
M7-5	BICYCLE DIRECTIONAL ARROW 2 HEADS 90 DEGREES/270 DEGREES	
M7-6	BICYCLE DIRECTIONAL ARROW 2 HEADS 360 DEGREES/90 DEGREES	
M7-7	BICYCLE DIRECTIONAL ARROW 2 HEADS 360 DEGREES/45 DEGREES	
M8-101	ROUTE MARKER ASSEMBLY W/ARROW*	
M8-201	ROUTE MARKER ASSEMBLY W/ARROWS*	
M8-301	ROUTE MARKER ASSEMBLY W/ARROWS*	
M8-401	ROUTE MARKER ASSEMBLY W/TWO SHIELDS*	

P SERIES

P-1	BEGINNING OF PROJECT
P-2	END OF PROJECT
P-3	STOCKPILE
P-4	PIT SITE
P-5	STOCK PILE _____ MILES
P-6	PIT SIZE/MILES*

R SERIES

R1-1	STOP	
R1-2	YIELD	
R1-2A	TO ONCOMING TRAFFIC	
R1-3	4-WAY*	
R1-4	ALL WAY	
R1-5L&R	YIELD HERE TO PEDESTRIANS	
R1-6A	IN-STREET PEDESTRIAN CROSSING	
R2-1	SPEED LIMIT _____	
R2-2	TRUCKS _____	

* denotes variable message sign

R2-3	NIGHT _____	
R2-4	MINIMUM SPEED _____	
R2-4A	SPEED LIMIT _____ MINIMUM _____	
R2-501	_____ MPH	
R3-1	NO RIGHT TURN SYMBOL	
R3-2	NO LEFT TURN SYMBOL	
R3-3	NO TURNS	
R3-4	NO U TURN SYMBOL	
R3-5	LEFT ONLY ARROW	
R3-5A	DOUBLE (LEFT ARROW) ONLY	
R3-501	(ARROW 360 DEGREES) STRAIGHT ONLY	
R3-6	LEFT TURN, STRAIGHT ARROWS	
R3-7L	LEFT LANE MUST TURN LEFT	
R3-7R	RIGHT LANE MUST TURN RIGHT	
R3-701	RIGHT LANE MUST EXIT	
R3-702	RIGHT TURN PERMITTED WITHOUT STOPPING	
R3-703	USE RIGHT LANE TO EXIT	
R3-8	(LEFT ARROW) ONLY (LEFT STRAIGHT ARROWS) (LEFT ARROW) ONLY (LEFT STRAIGHT ARROWS) (RIGHT ARROW)	
R3-8A	ONLY	
R3-801	(LEFT ARROW) ONLY (STRAIGHT ARROW) ONLY	
R3-802	(LEFT ARROW) ONLY (LEFT RIGHT ARROWS)	
R3-9A	(TWO WAY LEFT TURN)ONLY (OVERHEAD MOUNTED)	
R3-9B	CENTER LANE (TWO WAY LEFT TURN) ONLY (POST MOUNTED)	
R3-10	RESTRICTED LANE AHEAD	
R3-102	LEFT LANE RESTRICTION 1/4 MI. AHEAD	
R3-103	LEFT LANE RESTRICTION AHEAD	
R3-11	_____ BUSES AND CAR POOLS ONLY _____	
R3-1102L	LT LANE (BUS & _____ CARPOOL SYMBOLS) ONLY ____ AM - ____ PM MOTORCYCLES OK	
R3-1102R	RT LANE (BUS & _____ CARPOOL SYMBOLS) ONLY ____ AM - ____ PM MOTORCYCLES OK	
R3-1103L	LEFT LANE (BUS & _____ CARPOOL SYMBOLS) ONLY, MOTORCYCLES OK	
R3-1103R	RIGHT LANE (BUS & _____ CARPOOL SYMBOLS) ONLY, MOTORCYCLES OK	
R3-1104L	LEFT LANE (BUS & _____ PERSON CARPOOL SYMBOLS) ARROW	
R3-1104R	RIGHT LANE (BUS & _____ PERSON CARPOOL SYMBOLS) ARROW	
R3-12	RESTRICTED LANE ENDS	
R3-1201	LEFT LANE RESTRICTION ENDS	
R3-1202	LEFT LANE RESTRICTION ENDS 1/4 MI.	
R3-1203	RESTRICTED LANE EXIT ONLY	
R3-1204	LEFT LANE OPEN TO ALL TRAFFIC	
R3-13	RESTRICTED LANE AHEAD	
R3-14	BUSES AND _____ PERSON CAR POOLS ONLY _____ ARROW 180 _____	

* denotes variable message sign

R3-1401	(BUS & ____ PERSON CARPOOL SYMBOLS) ONLY ARROW 180 (BUS & ____ PERSON CARPOOL SYMBOLS) ____ AM - ____ PM ONLY	
R3-1402	ARROW 180	
R3-15	RESTRICTED LANE ENDS	
R3-1502	TRANSIT LANE ENDS	
R3-1503	TRANSIT LANE ENDS ____ MILES	
R3-17	(BIKE SYMBOL) ONLY	
R3-17A	LEFT (BIKE SYMBOL) RIGHT (PARKING ALLOWED SYMBOL) ONLY	
R3-17B	AHEAD	
R3-17C	ENDS	
R3-18	COMBINED U-TURN & LEFT TURN PROHIBITION	
R3-2001	RIGHT LANE BUSES ONLY	
R3-2002	TRANSIT (BUS SYMBOL) ONLY	
R3-2003	TRANSIT ONLY ARROW 315	
R3-2004	RIGHT LANE TRANSIT ONLY EXCEPT RIGHT TURNS RIGHT LANE (BUS & ____ PERSON CARPOOL SYMBOL) EXCEPT	
R3-2005	RIGHT TURNS	
R4-1	DO NOT PASS	
R4-2	PASS WITH CARE	
R4-3	SLOWER TRAFFIC KEEP RIGHT	
R4-301	KEEP RIGHT EXCEPT TO PASS VEHICLES WITH TRAILERS OR OVER 10,000 LBS PROHIBITED IN LEFT	
R4-302	LANE	
R4-302A	TRUCKS OVER 10,000 LBS USE RIGHT ____ LANES ONLY VEHICLES WITH TRAILERS OR OVER 10,000 LBS USE	
R4-302B	RIGHT ____ LANES ONLY	
R4-4	BEGIN RIGHT TURN LANE-YIELD TO BIKES	
R4-5	TRUCKS USE RIGHT LANE	
R4-6	TRUCK LANE ____ FEET	
R4-601	PASSING LANE _____ MILES	
R4-602	NEXT PASSING LANE _____ MILES	
R4-604	USE OF COMPRESSION BRAKES PROHIBITED	
R4-605	UNMUFFLED COMPRESSION BRAKES PROHIBITED	
R4-7	KEEP RIGHT SYMBOL	
R4-7A	KEEP RIGHT HORIZONTAL ARROW	
R4-7B	KEEP RIGHT 30 DEGREE ARROW	
R4-8	KEEP LEFT SYMBOL	
R4-9	STAY IN LANE	
R4-901	NO PASSING ON BRIDGE	
R4-10	RUNAWAY VEHICLES ONLY	
R5-1	DO NOT ENTER	
R5-1A	WRONG WAY	
R5-1B	BICYCLES WRONG WAY	
R5-2	NO TRUCKS SYMBOL	
R5-3	NO MOTOR VEHICLES	
R5-4	COMMERCIAL VEHICLES EXCLUDED	
R5-5	VEHICLES WITH LUGS PROHIBITED	

* denotes variable message sign

R5-6	NO BICYCLES SYMBOL	
R5-601	BICYCLES MUST EXIT	
R5-602	BICYCLES AND MOTORIZED FOOT SCOOTERS MUST EXIT ____ MILE	
R5-10A	PEDS, BICYCLES, MOTOR-DRIVEN CYCLES PROHIBITED	
R5-10B	PEDESTRIANS AND BICYCLES PROHIBITED	
R5-10C	PEDESTRIANS PROHIBITED	
R5-1001	PEDESTRIANS, HITCHHIKERS, PROHIBITED	
R5-1002	PEDESTRIANS, HITCHHIKERS, BICYCLES PROHIBITED	
R5-1003	BICYCLES AND MOTORIZED FOOT SCOOTERS PROHIBITED	
	PEDESTRIANS, HITCHHIKERS, BICYCLES, AND MOTORIZED	
R3-1004	FOOT SCOOTERS PROHIBITED	
R5-1201	MOTORCYCLES ONLY	
R5-1301	COMPACT CARS ONLY	
R6-1 L	ONE WAY (LEFT)	
R6-1 R	ONE WAY (RIGHT)	
R6-2 L	ONE WAY (LEFT)	
R6-2 R	ONE WAY (RIGHT)	
R6-3	DIVIDED HIGHWAY	
R6-3A	DIVIDED HIGHWAY	
R7-1	NO PARKING ANYTIME (ARROW)	
R7-101	NO PARKING ANYTIME	
R7-102	NO PARKING ANYTIME (DOUBLE HEADED ARROW)	
R7-107	NO PARKING BUS STOP (ARROW)	
R7-107A	NO PARKING BUS STOP SYMBOL WITH TRANSIT LOGO	
R7-108	RESTRICTED PARKING XXXX TO XXXX *	
R7-2	NO PARKING XXXX TO XXXX *	
R7-2A	NO PARKING SYMBOL (TIME) TO (TIME)*	
R7-201	TOW-AWAY ZONE	
R7-201A	TOW-AWAY ZONE SYMBOL	
R7-202	NO PARKING (TIME) TO (TIME)*	
R7-203	EMERGENCY SNOW ROUTE, NO PARKING IF OVER TWO INCHES	
R7-3	NO PARKING EXCEPT SUNDAYS AND HOLIDAYS (ARROW)	
R7-301	NO PARKING EXCEPT SUNDAYS	
R7-4	NO STANDING ANYTIME _____ ARROW	
R7-401	NO STOPPING OR STANDING W / ARROW	
R7-402	NO STOPPING OR STANDING	
R7-5	ONE HOUR PARKING (TIME) TO (TIME)*	
R7-6	NO PARKING LOADING ZONE (DOUBLE ARROW)	
R7-601	NO PARKING LOADING ZONE	
R7-7	NO PARKING BUS STOP _____ ARROW	
R7-701	NO PARKING BUS STOP	
R7-801	RESERVED PARKING (DISABLED LOGO)	
R7-801A	VAN ACCESSIBLE	
R7-801P	STATE DISABLED PARKING PERMIT REQUIRED	
R7-9	NO PARKING BIKE LANE	
R7-9A	NO PARKING SYMBOL BIKE LANE	
R7-10801	15 MINUTE PARKING*	

* denotes variable message sign

R7-10802	PARALLEL PARKING ONLY
R8-1	NO PARKING ON PAVEMENT
R8-2	NO PARKING EXCEPT ON SHOULDER
R8-3	NO PARKING
R8-3A	NO PARKING SYMBOL
R8-3AP	EXCEPTION PLAQUE*
R8-3C	ON PAVEMENT
R8-3D	ON BRIDGE
R8-301	NO PARKING BEYOND THIS POINT
R8-4	EMERGENCY PARKING ONLY
R8-5	NO STOPPING ON PAVEMENT
R8-6	NO STOPPING EXCEPT ON SHOULDERS
R8-7	EMERGENCY STOPPING ONLY
R8-8	NO STOPPING ON TRACKS
R8-9	TRACKS OUT OF SERVICE
R8-1201	48 HOURS MAXIMUM PARKING
R9-1	WALK ON LEFT FACING TRAFFIC
R9-2	CROSS ONLY AT CROSSWALKS
R9-3	NO PEDESTRIAN CROSSING
R9-3A	NO PEDESTRIAN CROSSING SYMBOL
R9-3BL	USE CROSSWALK (ARROW LEFT)
R9-3BR	USE CROSSWALK (ARROW RIGHT)
R9-3C	RIDE WITH TRAFFIC
R9-4	NO HITCHHIKING
R9-4A	NO HITCHHIKING SYMBOL
R9-5	BIKE (SYMBOL) USE PEDESTRIAN SIGNAL
R9-6	BIKE (SYMBOL) YIELD TO PEDS
R9-7	KEEP LEFT/RIGHT (PED & BIKE SYMBOLS)*
R9-8	PEDESTRIAN CROSSWALK
R9-9	SIDEWALK CLOSED
R9-10	SIDEWALK CLOSED (DOUBLE HEADED ARROW) USE OTHER SIDE
R9-11	SIDEWALK CLOSED AHEAD (SINGLE HEAD ARROW) CROSS HERE
R9-11A	SIDEWALK CLOSED (SINGLE HEAD ARROW) CROSS HERE
R10-1	CROSS ON GREEN LIGHT ONLY
R10-2	CROSS ON WALK SIGNAL ONLY
R10-2A	CROSS ON WALK SIGNAL ONLY WITH MAN SYMBOL
R10-3	PUSH BUTTON FOR GREEN LIGHT
R10-3A	TO CROSS STREET PUSH BUTTON - WAIT FOR GREEN LIGHT
R10-4	PUSH BUTTON FOR WALK SIGNAL
R10-4A	TO CROSS STREET PUSH BUTTON WAIT FOR WALK SIGNAL
R10-4001	PUSH BUTTON FOR WALK SIGNAL-DIRECTIONAL ARROW LEFT
R10-4002	PUSH BUTTON FOR WALK SIGNAL-DIRECTIONAL ARROW RIGHT
R10-5	LEFT ON ARROW ONLY
R10-6L	STOP HERE ON RED DIRECTIONAL ARROW
R10-6R	STOP HERE ON RED DIRECTIONAL ARROW
R10-6A	STOP HERE ON RED CURVED ARROW

* denotes variable message sign

R10-601L&R	STOP HERE ON RED DIRECTIONAL ARROW 1 CAR PER GREEN	
R10-7	DO NOT BLOCK INTERSECTION	
R10-701	ONE VEHICLE IN MEDIAN AT A TIME	
R10-8	USE LANE WITH GREEN ARROW	
R10-10L	LEFT TURN SIGNAL	
R10-10R	RIGHT TURN SIGNAL	
R10-11	NO TURN ON RED BALL	
R10-11A	NO TURN ON RED	
R10-11B	NO TURN ON RED	
R10-11C	(NO RIGHT TURN SYMBOL) ON RED	
R10-11D	(NO LEFT TURN SYMBOL) ON RED	
R10-12	LEFT TURN YIELD ON GREEN BALL	
R10-1201	LEFT TURN MUST YIELD	
R10-13	EMERGENCY SIGNAL	
R10-1401	TWO CARS PER GREEN	
R10-1402	1 CAR PER GREEN THIS LANE	
R10-1403	1 CAR PER GREEN EACH LANE	
R10-1404	ONE CAR PER GREEN	
R10-1405	ONE CAR PER GREEN EACH LANE	
R10-15	TURNING TRAFFIC MUST YIELD TO PEDESTRIANS	
R10-16	U-TURN YIELD TO RIGHT TURN	
R10-17A	RIGHT ON RED ARROW AFTER STOP	
R10-18	TRAFFIC LAWS PHOTO ENFORCED	
R10-19	PHOTO ENFORCED	
R10-20A	MON-FRI ___ AM ___ PM	
R10-20B	SUNDAY ___ AM	
R10-21	LEFT TURN SIGNAL - YIELD ON GREEN BALL	
R10-22	TO REQUEST GREEN WAIT ON BICYCLIST SYMBOL	
R11-1	KEEP OFF MEDIAN	
R11-2	ROAD CLOSED	
R11-201	RAMP CLOSED	
R11-3	ROAD CLOSED _____ MILES AHEAD LOCAL TRAFFIC ONLY	
R11-3A	BRIDGE OUT _____ MILES AHEAD LOCAL TRAFFIC ONLY	
R11-3(MOD.)	MILITARY ROAD CLOSED _____ MILES AHEAD LOCAL TRAFFIC ONLY	
R11-4	ROAD CLOSED TO THRU TRAFFIC	
R11-501	DO NOT DRIVE ON SHOULDER	
R11-1501	RAMP WILL BE CLOSED _____ EXIT WILL BE CLOSED _____	
R12-1	WEIGHT LIMIT ___ TONS	
R12-2	AXLE WEIGHT LIMIT _____ TONS	
R12-3	NO TRUCKS OVER _____ LBS. EMPTY WEIGHT	
R12-4	WEIGHT LIMIT _____ TONS PER AXLE _____ TONS GROSS	
R12-5	WEIGHT LIMIT TRUCK SYMBOLS W/WEIGHT*	
R12-501	WEIGHT RESTRICTIONS IN FORCE	
R12-502	EMERGENCY RESTRICTIONS IN FORCE	
R12-503	EMERGENCY RESTRICTIONS _____ MILES AHEAD ON HWY	
R12-1001	_____ ALL TRUCKS STOP BEFORE MOVING ON BRIDGE	

* denotes variable message sign

- R12-1101 ONE TRUCK AT A TIME ON BRIDGE
- R13-1 ALL TRUCKS COMMERCIAL VEHICLES NEXT RIGHT
- R13-201 TRUCKS OVER 10, 000 GVWR STOP AT SCALES WHEN OPEN
- R13-301 TRUCKS STOP AT SCALES/WEIGH STATION CLOSED
- R13-302 TRUCKS OVER 10,000 GVWR STOP AT SCALES/WEIGH STATION CLOSED
- R13-401 LIVESTOCK INSPECTION REQUIRED STOP AT WEIGH STATION
- R14-1 TRUCK ROUTE
- R14-2 HC SYMBOL
- R14-3 HC PROHIBITED SYMBOL
- R14-4 TRUCK SYMBOL
- R14-5 TRUCK PROHIBITED SYMBOL
- R15-1 R/R CROSSING(CROSS BUCK)
- R15-2 _____ TRACKS
- R15-3 EXEMPT
- R16-101 USE RIGHT SHOULDER TO INSTALL CHAINS
- R16-102 USE RIGHT SHOULDER TO REMOVE CHAINS
- R16-203 NOV 1 TO APR 1/EXCEPT ALL-WHEEL DRIVE
- R16-2100 ALL VEHICLES CARRY CHAINS
- R16-2101 VEHICLES OVER 10,000 GVWR CHAINS REQUIRED
- R16-2102 ALL VEHICLES CHAINS REQUIRED
- R16-2103 TRACTION ADVISORY OVERSIZED VEHICLES PROHIBITED
- R16-301 CHAIN ENFORCEMENT ENDS HERE
- R16-501 VEHICLES OVER 10,000 LBS GROSS MUST USE CHAINS
- R16-501A VEHICLES OVER 10,000 GVW USE CHAINS WHEN TRAC. TIRES REQ.
- R16-601 CHAIN-UP PARKING ONLY
- R16-701 CHAIN-OFF PARKING ONLY
- R17-101 KEEP OFF WET PAINT
- R17-2 NO TRESPASSING
- R18-101 NO FISHING FROM BRIDGE
- R18-201 DO NOT ROLL ROCKS ENDANGERS PEOPLE BELOW
- R18-301 NO DUMPING ALLOWED

S SERIES

- S1-1 SCHOOL ADVANCE SIGN
- S3-1 SCHOOL BUS STOP AHEAD
- S3-201 SCHOOL BUS TURNAROUND
- S4-1 _____ TO _____
- S4-2 WHEN CHILDREN ARE PRESENT
- S4-3 SCHOOL
- S4-4 WHEN FLASHING
- S4-5 & 5A SCHOOL DAYS ____AM - ____PM or (5A) ____AM - ____AM & ____PM - ____PM
- S4-501 WHEN FLAGGED
- S5-1 SCHOOL SPEED LIMIT 20 WHEN FLASHING
- S5-101 SCHOOL SPEED LIMIT 20 WHEN CHILDREN ARE PRESENT
- S5-2 END SCHOOL ZONE

W SERIES

W1-1L	LEFT TURN	
W1-1R	RIGHT TURN	
W1-2L	CURVE LEFT	
W1-2R	CURVE RIGHT	
W1-3L	REVERSE TURN LEFT	
W1-3R	REVERSE TURN RIGHT	
W1-4L	REVERSE CURVE LEFT	
W1-4R	REVERSE CURVE RIGHT	
W1-4BR	2 CURVE RIGHT ARROWS	
W1-4CR	3 CURVE RIGHT ARROWS	
W1-5L	WINDING ROAD LEFT	
W1-5R	WINDING ROAD RIGHT	
W1-6	LARGE ARROW _____	
W1-7	LARGE ARROW (2-HEADS)	
W1-8	CHEVRON ALIGNMENT SIGN	
W1-901L	180 DEGREE CURVE LEFT	
W1-901R	180 DEGREE CURVE RIGHT	
W1-101L/R	HORIZONTAL ALIGNMENT	
W1-15	270 DEGREE LOOP	
W2-1	CROSS ROAD SYMBOL	
W2-2	SIDE ROAD SYMBOL	
W2-3	SIDE ROAD SYMBOL 45 DEGREES	
W2-4	T (SYMBOL)	
W2-401	ARROW (315 DEGREES)	
W2-5	Y (SYMBOL)	
W2-6	ROUNDAABOUT AHEAD (SYMBOL)	
W2-6P	ROUNDAABOUT AHEAD PLAQUE	
W2-601	LEFT TURNS AHEAD	
W3-1	STOP AHEAD	
W3-1A	STOP AHEAD (SYMBOL)	
W3-2A	YIELD AHEAD (SYMBOL)	
W3-3	SIGNAL AHEAD (SYMBOL)	
W3-401	EMERGENCY SIGNAL AHEAD	
W3-5	SPEED LIMIT REDUCTION AHEAD	
W3-501	RAMP METERING AHEAD WHEN FLASHING	
W4-1L	MERGING FROM LEFT	
W4-1R	MERGING FROM RIGHT	
W4-2L	PAVEMENT WIDTH TRANSITION LEFT	
W4-2R	PAVEMENT WIDTH TRANSITION RIGHT	
W4-3L	ADDED LANE SYMBOL LEFT	
W4-3R	ADDED LANE SYMBOL RIGHT	
W4-4P	CROSS TRAFFIC DOES NOT STOP	
W4-5	ENTERING ROADWAY MERGE	
W4-6	ENTERING ROADWAY ADDED LANE	
W5-1	ROAD NARROWS	
W5-2	NARROW BRIDGE	
W5-3	ONE LANE BRIDGE	
W5-4	BIKEWAY NARROWS	
W6-1	DIVIDED HIGHWAY	

W6-2	DIVIDED HIGHWAY ENDS
W6-3	TWO WAY TRAFFIC (SYMBOL)
W6-401	FREEWAY ENDS _____ MILE
W7-1	HILL SYMBOL
W7-101	HILL
W7-2B	TRUCKS USE LOWER GEAR
W7-3	_____ % GRADE
W7-3A	NEXT _____ MILES
W7-3B	_____ % GRADE _____ MILES
W7-4	RUNAWAY TRUCK RAMP _____ MILE
W7-4A	RUNAWAY TRUCK RAMP ARROW _____ DEGREES
W7-4B	TRUCK ESCAPE RAMP
W7-4C,D,&E	TRUCK ESCAPE RAMP PLAQUES, SAND, GRAVEL, & PAVED
W7-5	HILL (BICYCLE SYMBOL)
W8-1	BUMP
W8-2	DIP
W8-3	PAVEMENT ENDS
W8-4	SOFT SHOULDER
W8-5	SLIPPERY WHEN WET SYMBOL
W8-6	TRUCK CROSSING
W8-7	LOOSE GRAVEL
W8-8	ROUGH ROAD
W8-10	SLIPPERY WHEN WET (BICYCLE SYMBOL)
W8-11	UNEVEN LANES
W8-12	NO CENTER STRIPE
W8-1501	WATER OVER ROADWAY
W8-1601	WATCH FOR ICE
W8-1701	ROCKS
W8-1801	NO SHOULDER
W8-1901	SLIDE AREA
W8-2001	GROOVED PAVEMENT
W8-2101	GRATED BRIDGE DECK
W8-2201	PAVEMENT RUTS
W9-1L	LEFT LANE ENDS
W9-1R	RIGHT LANE ENDS
W9-2L	LANE ENDS MERGE LEFT
W9-2R	LANE ENDS MERGE RIGHT
W10-1	RAILROAD ADVANCE SIGN
W10-101	EXEMPT PLAQUE
W10-1A	EXEMPT PLAQUE
W10-101P	BICYCLES USE CAUTION PLAQUE
W10-2	CROSSROADS RAILROAD SIGN
W10-3	SIDE ROAD RAILROAD SIGN _____
W10-4	T SYMBOL RAILROAD SIGN
W10-9	NO TRAIN HORN
W10-10	NO SIGNAL
W10-11A	_____ FEET BETWEEN TRACKS AND HIGHWAY
W10-12	SKEWED CROSSING
W10-13	NO GATES OR LIGHTS
W11A-301	CROSSWALK (OVERHEAD)

W11A-501	PEDESTRIANS/BICYCLES
W11-1	BICYCLE CROSSING
W11-2	ADVANCE PEDESTRIAN CROSSING
W11-3	DEER CROSSING
W11-4	CATTLE CROSSING
W11-5	FARM MACHINERY
W11-6	SNOWMOBILE CROSSING
W11-7	EQUESTRIAN CROSSING
W11-8	FIRE STATION
W11-9	HANDICAPPED CROSSING
W11-10	TRUCK CROSSING (SYMBOL)
W11-101	BIKES ON ROAD
W11-12P	EMERGENCY SIGNAL AHEAD
W11-1301	CEMETERY ENTRANCE
W12-1	DOUBLE ARROW
W12-2	LOW CLEARANCE SYMBOL _____ FT _____ INCH
W12-301	LOW CLEARANCE _____ FT _____ INCH
W12-302	L/R LOW CLEARANCE MARKER LT./RT.*
W12-401L	LATERAL CLEARANCE MARKER (LEFT)
W12-401R	LATERAL CLEARANCE MARKER (RIGHT)
W12-501	IMPACT ATTENUATOR MARKING
W12-502	IMPACT ATTENUATOR MARKING
W13-1	_____ MPH
W13-2	EXIT _____ MPH
W13-3	RAMP _____ MPH
W13-4	ON RAMP
W13-401	FOR _____ MI.
W13-501	_____ MILES
W14-1	DEAD END
W14-1P	DEAD END WITH ARROW
W14-2	NO OUTLET
W14-2P	NO OUTLET WITH ARROW
W14-3	NO PASSING ZONE
W14-501	TUNNEL
W14-601	SLOW MOVING VEHICLE
W14-701	LOW FLYING AIRCRAFT
W14-801	SEVERE SIDE WIND AHEAD
W14-901	SLOW MOVING VEHICLE (SYMBOL)
W14-1001	DRAW BRIDGE
W14-1002	DRAW BRIDGE AHEAD
W14-1101	TRANSIT STOP AHEAD (SYMBOL)
W14-1601	MOUNTAIN PASS AHEAD DRIVE CAREFULLY
W14-2202	CONGESTED AREA
W14-2203	CONGESTION AHEAD
W15-1	PLAYGROUND (SYMBOL)
W15-201	FIRE STATION AHEAD
W15-301	HOSPITAL

* denotes variable message sign

W16-101	END OF ROAD MARKER (REFL)
W16-102	END OF ROAD MARKER (NON-REFL)
W16-5PL	SUPPLEMENTAL ARROW 90 PLAQUE (LEFT)
W16-5PR	SUPPLEMENTAL ARROW 270 PLAQUE (RIGHT)
W16-6PL	ADVANCE SUPPLEMENTAL ARROW 90 PLAQUE (LEFT)
W16-6PR	ADVANCE SUPPLEMENTAL ARROW 270 PLAQUE (RIGHT)
W16-7L	DIAGONAL DOWNWARD ARROW 135 PLAQUE (LEFT)
W16-7R	DIAGONAL DOWNWARD ARROW 215 PLAQUE (RIGHT)
W16-9P	AHEAD
W16-10	PHOTO ENFORCED
W17-1	SPEED HUMP
W20-1	ROAD WORK AHEAD
W20-2	DETOUR AHEAD
W20-3	ROAD/STREET/RAMP CLOSED AHEAD*
W20-301	SHOULDER CLOSED
W20-303	RIGHT SHOULDER CLOSED
W20-4	ONE LANE ROAD AHEAD
W20-5	RIGHT/LEFT LANE CLOSED AHEAD*
W20-501	RIGHT TWO LANES CLOSED AHEAD
W20-7A	FLAGGER (SYMBOL)
W20-7B	BE PREPARED TO STOP
W20-901	TRAFFIC REVISION AHEAD
W20-902	NEW SIGNAL AHEAD
W20-903	SIGNAL REVISION AHEAD
W21-1A	WORK CREW (SYMBOL)
W21-2	FRESH OIL/TAR
W21-3	ROAD MACHINERY AHEAD
W21-30	TRUCKS ENTERING HIGHWAY
W21-30A	TRUCKS LEAVING HIGHWAY
W21-5	SHOULDER WORK
W21-6	SURVEY CREW
W21-701	SHOULDER DROP-OFF
W21-801	ABRUPT LANE EDGE
W21-901	BRIDGE REPAIR AHEAD
W21-1001	BRIDGE PAINTING AHEAD
W21-1201	FLAGGER'S PADDLE
W21-1202	HANDLE AND STAFF FOR FLAG PADDLE
W21-1601	FLYING ROCK
W21-1701	MOTORCYCLES USE EXTREME CAUTION
W22-1	BLASTING ZONE AHEAD
W22-2	TURN OFF 2-WAY RADIO AND CELLULAR PHONES
W22-3	END BLASTING ZONE
W24-101	TRAFFIC SURVEY AHEAD

* denotes variable message sign

APPENDICES

Appendix A Sign Sizing, Layout, and Spacing	
Appendix B Guide Sign Arrows	
Appendix C Letter Spacing for Upper and Lower Case	
Appendix D Graphics Templates	
Appendix E Express Lane Gate Arm	

W21-801	ABRUPT LANE EDGE
W4-3L	ADDED LANE SYMBOL LEFT
W4-3R	ADDED LANE SYMBOL RIGHT
I6-901A	ADOPT-A-HIGHWAY (LARGE)
I6-901	ADOPT-A-HIGHWAY (SMALL)
I6-902	ADOPT-A-HIGHWAY "GROUP'S NAME (HERE)"(SMALL)
I6-903A	ADOPT-A-HIGHWAY "THIS AREA AVAILABLE"/PHONE NUMBER (LARGE)
I6-903	ADOPT-A-HIGHWAY "THIS AREA AVAILABLE"/PHONE NUMBER (SMALL)
I6-902A	ADOPT-A-HIGHWAY "GROUP'S NAME (HERE)"(LARGE)
I6-904	ADOPT-A-HIGHWAY LITTER CONTROL
I6-905A	ADOPT-A-HIGHWAY MEDIAN NEXT _____MILES
D1-501	ADVANCE DESTINATION W/ROUTE MARKER*
D1-401	ADVANCE DESTINATION*
E1-1	ADVANCE GUIDE SIGN*
W11-2	ADVANCE PEDESTRIAN CROSSING
D3-2A	ADVANCE STREET NAME SIGN NEXT INTERSECTION
D3-2	ADVANCE STREET NAME SIGN W/ARROW
W16-6PR	ADVANCE SUPPLEMENTAL ARROW 270 PLAQUE (RIGHT)
W16-6PL	ADVANCE SUPPLEMENTAL ARROW 90 PLAQUE (LEFT)
M5-2	ADVANCE TURN ARROW 45 DEGREES
M5-2B	ADVANCE TURN ARROW 45 DEGREES
M5-1	ADVANCE TURN ARROW 90 DEGREES
M5-1B	ADVANCE TURN ARROW 90 DEGREES
E5-4	ADVISORY SPEED PLAQUE FOR EXIT GORE SIGN
R3-17B	AHEAD
W16-9P	AHEAD
I5-5	AIRPORT (SYMBOL)
R13-1	ALL TRUCKS COMMERCIAL VEHICLES NEXT RIGHT
R12-1001	ALL TRUCKS STOP BEFORE MOVING ON BRIDGE
R16-2100	ALL VEHICLES CARRY CHAINS
R16-2102	ALL VEHICLES CHAINS REQUIRED
R1-4	ALL WAY
M4-101	ALT PLAQUE
M4-1	ALTERNATE PLAQUE
D9-13B	AMBULANCE STATION
D1-901	APPROACH DIRECTIONAL SIGN - 1 DESTINATION*
D1-801	APPROACH DIRECTIONAL SIGN - 2 DESTINATIONS*
W2-401	ARROW (315 DEGREES)
R3-501	(ARROW 360 DEGREES) STRAIGHT ONLY
D9-401	ARROW SIGN
I6-801	AUTOMOBILE LITTER ONLY
R12-2	AXLE WEIGHT LIMIT _____ TONS
D10-401	BACK EQ. PLAQUE
W20-7B	BE PREPARED TO STOP
D7-1402	BEACH
M4-11	BEGIN
M4-1101	BEGIN (BICYCLE ROUTE)
I30-301A	BEGIN CHECK MILE _____

* denotes variable message sign

R4-4	BEGIN RIGHT TURN LANE-YIELD TO BIKES
P-1	BEGINNING OF PROJECT
W11-1	BICYCLE CROSSING
M4-9C	BICYCLE DETOUR
M7-7	BICYCLE DIRECTIONAL ARROW 2 HEADS 360 DEGREES/45 DEGREES
M7-6	BICYCLE DIRECTIONAL ARROW 2 HEADS 360 DEGREES/90 DEGREES
M7-3	BICYCLE DIRECTIONAL ARROW 2 HEADS 45 DEGREES/225 DEGREES
M7-5	BICYCLE DIRECTIONAL ARROW 2 HEADS 90 DEGREES/270 DEGREES
M7-2	BICYCLE DIRECTIONAL ARROW 360 DEGREES
M7-4	BICYCLE DIRECTIONAL ARROW 45 DEGREES
M7-1	BICYCLE DIRECTIONAL ARROW 90 DEGREES
M4-9A	BICYCLE/PEDESTRIAN DETOUR
R5-602	BICYCLES AND MOTORIZED FOOT SCOOTERS MUST EXIT ____ MILE
R5-1003	BICYCLES AND MOTORIZED FOOT SCOOTERS PROHIBITED
R5-601	BICYCLES MUST EXIT
W10-101P	BICYCLES USE CAUTION PLAQUE
R5-1B	BICYCLES WRONG WAY
M1-9	____ BIKE SYMBOL (INTERSTATE BIKE ROUTE MARKER)
R9-5	BIKE (SYMBOL) USE PEDESTRIAN SIGNAL
R9-6	BIKE (SYMBOL) YIELD TO PEDS
D11-1	BIKE ROUTE
M1-8	BIKE SYMBOL ____ (BICYCLE ROUTE MARKER)
W11-101	BIKES ON ROAD
W5-4	BIKEWAY NARROWS
W22-1	BLASTING ZONE AHEAD
I7-301	BRIDGE NUMBER
R11-3A	BRIDGE OUT ____ MILES AHEAD LOCAL TRAFFIC ONLY
W21-1001	BRIDGE PAINTING AHEAD
W21-901	BRIDGE REPAIR AHEAD
W8-1	BUMP
I5-6	BUS STATION (SYMBOL)
R3-11	____ BUSES AND CAR POOLS ONLY _____ (BUS & ____ PERSON CARPOOL SYMBOLS) ____ AM - ____ PM ONLY
R3-1402	ARROW 180
R3-1401	(BUS & ____ PERSON CARPOOL SYMBOLS) ONLY ARROW 180
R3-14	BUSES AND ____ PERSON CAR POOLS ONLY ____ ARROW 180 ____
M4-3	BUSINESS
M4-2	BYPASS
D12-201	CAR POOL INFO _____
D12-202	CAR POOL INFO W/SYMBOL _____
W11-4	CATTLE CROSSING
I7-7	CAUTION-NO WARNING SIGNS
W11-1301	CEMETERY ENTRANCE
R3-9B	CENTER LANE (TWO WAY LEFT TURN) ONLY (POST MOUNTED)
R16-301	CHAIN ENFORCEMENT ENDS HERE
R16-701	CHAIN-OFF PARKING ONLY
R16-601	CHAIN-UP PARKING ONLY

W1-8	CHEVRON ALIGNMENT SIGN
I2-301	CITY ENTRANCE SIGN*
E8-2	CITY INTERCHANGE SEQUENCE*
E9-1	CITY NEXT _____ EXITS*
I8-706	CLEAN WATER - USE FOR FILLING DOMESTIC TANKS ONLY
R3-18	COMBINED U-TURN & LEFT TURN PROHIBITION
I8-704	COMMERCIAL VEHICLE USE PROHIBITED
R5-4	COMMERCIAL VEHICLES EXCLUDED
R5-1301	COMPACT CARS ONLY
W14-2202	CONGESTED AREA
W14-2203	CONGESTION AHEAD
I2-201	COUNTY ENTRANCE SIGN*
R10-1	CROSS ON GREEN LIGHT ONLY
R10-2	CROSS ON WALK SIGNAL ONLY
R10-2A	CROSS ON WALK SIGNAL ONLY WITH MAN SYMBOL
R9-2	CROSS ONLY AT CROSSWALKS
W2-1	CROSS ROAD SYMBOL
W4-4P	CROSS TRAFFIC DOES NOT STOP
D13-3	CROSSOVER 1/4 MILE
D13-2	CROSSOVER W/ARROW
D3-102	CROSSROADS NAME SIGN
D3-302	CROSSROADS NAME SIGN W/CHEVRON*
D3-201	CROSSROADS NAME SIGN*
D3-301	CROSSROADS NAME SIGN*
W10-2	CROSSROADS RAILROAD SIGN
W11A-301	CROSSWALK (OVERHEAD)
W1-2L	CURVE LEFT
W1-2R	CURVE RIGHT
I8-701	DAYLIGHT HOURS ONLY
W14-1	DEAD END
W14-1P	DEAD END WITH ARROW
W11-3	DEER CROSSING
I8-201	DELAY OF 5 VEHICLES ILLEGAL MUST USE TURNOUTS
I6-101	DEPOSIT LITTER _____ MILE(S)
M4-8	DETOUR
W20-2	DETOUR AHEAD
W16-7L	DIAGONAL DOWNWARD ARROW 135 PLAQUE (LEFT)
W16-7R	DIAGONAL DOWNWARD ARROW 215 PLAQUE (RIGHT)
E1-4	DIAGRAMMATIC*
W8-2	DIP
M6-7	DIRECTIONAL ARROW 2 HEADS 360 DEGREES/45 DEGREES
M6-7B	DIRECTIONAL ARROW 2 HEADS 360 DEGREES/45 DEGREES
M6-6	DIRECTIONAL ARROW 2 HEADS 360 DEGREES/90 DEGREES
M6-6B	DIRECTIONAL ARROW 2 HEADS 360 DEGREES/90 DEGREES
M6-5	DIRECTIONAL ARROW 2 HEADS 45 DEGREES/225 DEGREES
M6-5B	DIRECTIONAL ARROW 2 HEADS 45 DEGREES/225 DEGREES
M6-4	DIRECTIONAL ARROW 2 HEADS 90 DEGREES/270 DEGREES

* denotes variable message sign

M6-4B	DIRECTIONAL ARROW 2 HEADS 90 DEGREES/270 DEGREES
M6-3	DIRECTIONAL ARROW 360 DEGREES
M6-3B	DIRECTIONAL ARROW 360 DEGREES
M6-2	DIRECTIONAL ARROW 45 DEGREES
M6-2B	DIRECTIONAL ARROW 45 DEGREES
M6-1	DIRECTIONAL ARROW 90 DEGREE
M6-1B	DIRECTIONAL ARROW 90 DEGREE
D9-501	DIRECTIONAL ARROW DETAILS (HORIZONTAL)
D9-502	DIRECTIONAL ARROW DETAILS (VERTICAL)
D1-701	DIRECTIONAL W/ROUTE MARKER*
R6-3	DIVIDED HIGHWAY
R6-3A	DIVIDED HIGHWAY
W6-1	DIVIDED HIGHWAY
W6-2	DIVIDED HIGHWAY ENDS
R10-7	DO NOT BLOCK INTERSECTION
R11-501	DO NOT DRIVE ON SHOULDER
R5-1	DO NOT ENTER
R4-1	DO NOT PASS
R18-201	DO NOT ROLL ROCKS ENDANGERS PEOPLE BELOW
R3-5A	DOUBLE (LEFT ARROW) ONLY
W12-1	DOUBLE ARROW
E3-101	DOUBLE EXIT OR NEXT RIGHT SECOND LEFT*
W14-1001	DRAW BRIDGE
W14-1002	DRAW BRIDGE AHEAD
I8-708	DUMP STATION INSTRUCTIONS
M3-2	EAST
M3-2B	EAST
D8-101	EMERGENCY CALL BOX
D9-13C	EMERGENCY MEDICAL CARE
R8-4	EMERGENCY PARKING ONLY
R12-503	EMERGENCY RESTRICTIONS _____ MILES AHEAD ON HWY _____
R12-502	EMERGENCY RESTRICTIONS IN FORCE
R10-13	EMERGENCY SIGNAL
W3-401	EMERGENCY SIGNAL AHEAD
W11-12P	EMERGENCY SIGNAL AHEAD
R7-203	EMERGENCY SNOW ROUTE, NO PARKING IF OVER TWO INCHES
R8-7	EMERGENCY STOPPING ONLY
M4-6	END
M4-12	END
M4-1201	END (BICYCLE ROUTE)
W22-3	END BLASTING ZONE
I30-301	END CHECK MILE _____
G20-601	END LANE CLOSURE
P-2	END OF PROJECT
W16-102	END OF ROAD MARKER (NON-REFL)
W16-101	END OF ROAD MARKER (REFL)
G20-2A	END ROAD WORK

* denotes variable message sign

S5-2	END SCHOOL ZONE
I8-601	END SHOULDER DRIVING
R3-17C	ENDS
I8-804	ENTERING FIRE DISTRICT NO. _____
I2-601	ENTERING LIMITED ACCESS AREA
W4-6	ENTERING ROADWAY ADDED LANE
W4-5	ENTERING ROADWAY MERGE
W11-7	EQUESTRIAN CROSSING
R8-3AP	EXCEPTION PLAQUE*
R15-3	EXEMPT
W10-101	EXEMPT PLAQUE
E5-1	EXIT (ARROW DEGREES)
W13-2	EXIT _____ MPH
E5-2B	EXIT CLOSED
E6-101	EXIT DIRECTION*
E5-1A	EXIT GORE SIGN WITH EXIT NUMBER AND ARROW*
E5-3	EXIT NUMBER PLAQUE FOR EXIT GORE SIGN
E5-2	EXIT ONLY
E4-501	EXIT ONLY GUIDE SIGN W/ARROW*
E11-1	EXIT ONLY PANELS
E5-2A	EXIT OPEN
E1-5	EXIT PANEL*
W11-5	FARM MACHINERY
W10-11A	_____ FEET BETWEEN TRACKS AND HIGHWAY
I5-801	FERRY (SYMBOL/CAR BOARDING FERRY)
I5-801A	FERRY (SYMBOL/FERRY)
R7-10801	15 MINUTE PARKING*
I7-401	FIRE HYDRANT MARKER
W11-8	FIRE STATION
W15-201	FIRE STATION AHEAD
W20-7A	FLAGGER (SYMBOL)
W21-1201	FLAGGER'S PADDLE
W21-1601	FLYING ROCK
D9-103	FOOD - GAS - LODGING NEXT RIGHT*
D9-102	FOOD - PHONE - GAS - LODGING NEXT RIGHT*
D9-101	FOOD - PHONE - GAS - LODGING, ETC.*
LG-M4	FOOD (FREEWAY DOUBLE EXIT)*
LG-M3	FOOD EXIT XXX (FREEWAY)*
LG-M3A	FOOD EXIT XXX, VERTICAL PANEL (FREEWAY)*
W13-401	FOR _____ MI.
G24-501	FOR PROJECT INFORMATION _____
R8-1201	48 HOURS MAXIMUM PARKING
R1-3	4-WAY*
D13-1	FREE COFFEE
W6-401	FREEWAY ENDS _____ MILE
E12-201	FREEWAY ENTRANCE
W21-2	FRESH OIL/TAR

* denotes variable message sign

LG-M2	GAS (FREEWAY DOUBLE EXITS)*
LG-M1	GAS EXIT XXX, HORIZONTAL PANEL (FREEWAY)*
LG-M1A	GAS EXIT XXX, VERTICAL PANEL (FREEWAY)*
LG-R1	GAS FOOD LODGING (RAMPS)*
LG-R4	GAS, FOOD (RAMPS WITH ROUNDABOUTS)*
LG-CI	GAS, FOOD, LODGING NEXT RIGHT/LEFT (CONVENTIONAL ROADS)*
W8-2101	GRATED BRIDGE DECK
W8-2001	GROOVED PAVEMENT
W11-9	HANDICAPPED CROSSING
W21-1202	HANDLE AND STAFF FOR FLAG PADDLE
R14-3	HC PROHIBITED SYMBOL
R14-2	HC SYMBOL
I5-103	HERITAGE MARKER _____ MILE
I5-104	HERITAGE MARKER W/ARROW
E12-101	HIGHWAY ENTRANCE
W7-101	HILL
W7-5	HILL (BICYCLE SYMBOL)
W7-1	HILL SYMBOL
I7-901	HITCHHIKING PERMITTED
W1-10IL/R	HORIZONTAL ALIGNMENT
W15-301	HOSPITAL
D9-13A	HOSPITAL
W12-501	IMPACT ATTENUATOR MARKING
W12-502	IMPACT ATTENUATOR MARKING
I20-203	IN MEMORY OF _____
D7-301P	IN THE DISTANCE PLAQUE
R1-6A	IN-STREET PEDESTRIAN CROSSING
E8-1	INTERCHANGE SEQUENCE SIGN*
M1-1	INTERSTATE _____
M1-2	INTERSTATE BUSINESS LOOP _____
M1-3	INTERSTATE BUSINESS SPUR _____
M2-1	JCT
M2-2	JUNCTION _____
R4-8	KEEP LEFT SYMBOL
R9-7	KEEP LEFT/RIGHT (PED & BIKE SYMBOLS)*
R11-1	KEEP OFF MEDIAN
R17-101	KEEP OFF WET PAINT
R4-7B	KEEP RIGHT 30 DEGREE ARROW
R4-301	KEEP RIGHT EXCEPT TO PASS
R4-7A	KEEP RIGHT HORIZONTAL ARROW
R4-7	KEEP RIGHT SYMBOL
M4-10	L/R LEFT/RIGHT DETOUR (ARROW)
W12-302	L/R LOW CLEARANCE MARKER LT./RT.*
W9-2L	LANE ENDS MERGE LEFT
W9-2R	LANE ENDS MERGE RIGHT
W1-7	LARGE ARROW (2-HEADS)
W1-6	LARGE ARROW _____

* denotes variable message sign

W12-401L	LATERAL CLEARANCE MARKER (LEFT)
W12-401R	LATERAL CLEARANCE MARKER (RIGHT)
I8-705	LEAN WATER ARROW DIRECTIONAL
I2-701	LEAVING LIMITED ACCESS AREA
I2-501	LEAVING RANGE AREA
R3-802	(LEFT ARROW) ONLY (LEFT RIGHT ARROWS)
R3-8	(LEFT ARROW) ONLY (LEFT STRAIGHT ARROWS)
R3-8A	(LEFT ARROW) ONLY (LEFT STRAIGHT ARROWS) (RIGHT ARROW) ONLY
R3-801	(LEFT ARROW) ONLY (STRAIGHT ARROW) ONLY
R3-17A	LEFT (BIKE SYMBOL) RIGHT (PARKING ALLOWED SYMBOL) ONLY
R3-1104L	LEFT LANE (BUS & ____ PERSON CARPOOL SYMBOLS) ARROW
R3-1103L	LEFT LANE (BUS & ____ CARPOOL SYMBOLS) ONLY, MOTORCYCLES OK
W9-1L	LEFT LANE ENDS
R3-7L	LEFT LANE MUST TURN LEFT
R3-1204	LEFT LANE OPEN TO ALL TRAFFIC
R3-102	LEFT LANE RESTRICTION 1/4 MI. AHEAD
R3-103	LEFT LANE RESTRICTION AHEAD
R3-1201	LEFT LANE RESTRICTION ENDS
R3-1202	LEFT LANE RESTRICTION ENDS 1/4 MI.
R10-5	LEFT ON ARROW ONLY
R3-5	LEFT ONLY ARROW
W1-1L	LEFT TURN
R10-1201	LEFT TURN MUST YIELD
R10-10L	LEFT TURN SIGNAL
R10-21	LEFT TURN SIGNAL - YIELD ON GREEN BALL
R10-12	LEFT TURN YIELD ON GREEN BALL
R3-6	LEFT TURN, STRAIGHT ARROWS
W2-601	LEFT TURNS AHEAD
M4-9L/R	LEFT/RIGHT DETOUR (ARROW _____ DEGREES)
I4-301	LEWIS-CLARK TRAIL MARKER
I7-601	LIGHTS ?
I6-102	LITTER AND IT WILL HURT
I6-201	LITTER SYMBOL SIGN
R13-401	LIVESTOCK INSPECTION REQUIRED STOP AT WEIGH STATION
LG-M6	LODGING (FREEWAY DOUBLE EXIT)*
LG-M5	LODGING EXIT XXX (FREEWAY)*
LG-M5A	LODGING EXIT XXX, VERTICAL PANEL (FREEWAY)*
W8-7	LOOSE GRAVEL
W12-301	LOW CLEARANCE _____ FT _____ INCH
W12-2	LOW CLEARANCE SYMBOL _____ FT _____ INCH
W14-701	LOW FLYING AIRCRAFT
R3-1102L	LT LANE (BUS & ____ CARPOOL SYMBOLS) ONLY ____ AM - ____ PM
D7-1000	MOTORCYCLES OK
D7-1000	MARINE RECREATION AREA
W4-1L	MERGING FROM LEFT
W4-1R	MERGING FROM RIGHT
D5-602	_____ MILE

* denotes variable message sign

D10-101	MILE _____ (BACK TO BACK)
D10-201	MILE _____ (BACK TO BACK)
D10-301	MILE _____ (BACK TO BACK)
D10-1	MILE _____ (SINGLE FACED)
D10-2	MILE _____ (SINGLE FACED)
D10-3	MILE _____ (SINGLE FACED)
I30-401	MILE _____
W13-501	_____ MILES
R2-501	_____ MPH
W13-1	_____ MPH
E7-1	MILEAGE SIGN*
R11-3(MOD.)	MILITARY ROAD CLOSED _____ MILES AHEAD LOCAL TRAFFIC ONLY
R2-4	MINIMUM SPEED _____
R10-20A	MON-FRI ___ AM ___ PM
R5-1201	MOTORCYCLES ONLY
W21-1701	MOTORCYCLES USE EXTREME CAUTION
W14-1601	MOUNTAIN PASS AHEAD DRIVE CAREFULLY
D7-301L	MOUNTAIN PEAK - VIEW LEFT
D7-301R	MOUNTAIN PEAK - VIEW RIGHT
D7-301	MOUNTAIN PEAK - VIEW STRAIGHT AHEAD
I8-801	MOWING TEST AREA
D1-601	MULTILANE DESTINATION W/ARROW*
D1-602	MULTILANE DESTINATIONS W/ARROWS*
D1-603	MULTILANE DESTINATIONS W/ARROWS*
W5-2	NARROW BRIDGE
M1-7	_____ NATIONAL FOREST (FOREST SERVICE ROUTE MARKER)
W20-902	NEW SIGNAL AHEAD
W7-3A	NEXT ___ MILES
I7-702	NEXT _____ MILES
E2-1	NEXT EXIT _____ MILES
E2-1A	NEXT EXIT _____ MILES
R4-602	NEXT PASSING LANE _____ MILES
D5-102	NEXT REST AREA ___ MILES
E4-301	NEXT RIGHT GUIDE SIGN*
D9-1601	NEXT SERVICES _____ MILES
R2-3	NIGHT _____
R5-6	NO BICYCLES SYMBOL
D7-2202	NO CAMPING
W8-12	NO CENTER STRIPE
R18-301	NO DUMPING ALLOWED
R18-101	NO FISHING FROM BRIDGE
W10-13	NO GATES OR LIGHTS
R9-4	NO HITCHHIKING
R9-4A	NO HITCHHIKING SYMBOL
R3-2	NO LEFT TURN SYMBOL
R10-11D	(NO LEFT TURN SYMBOL) ON RED

* denotes variable message sign

R5-3	NO MOTOR VEHICLES
W14-2	NO OUTLET
W14-2P	NO OUTLET WITH ARROW
R8-3	NO PARKING
R7-202	NO PARKING (TIME) TO (TIME)*
R7-101	NO PARKING ANYTIME
R7-1	NO PARKING ANYTIME (ARROW)
R7-102	NO PARKING ANYTIME (DOUBLE HEADED ARROW)
R8-301	NO PARKING BEYOND THIS POINT
R7-9	NO PARKING BIKE LANE
R7-701	NO PARKING BUS STOP
R7-107	NO PARKING BUS STOP (ARROW)
R7-7	NO PARKING BUS STOP _____ ARROW
R7-107A	NO PARKING BUS STOP SYMBOL WITH TRANSIT LOGO
R8-2	NO PARKING EXCEPT ON SHOULDER
R7-301	NO PARKING EXCEPT SUNDAYS
R7-3	NO PARKING EXCEPT SUNDAYS AND HOLIDAYS (ARROW)
R7-601	NO PARKING LOADING ZONE
R7-6	NO PARKING LOADING ZONE (DOUBLE ARROW)
R8-1	NO PARKING ON PAVEMENT
R8-3A	NO PARKING SYMBOL
R7-2A	NO PARKING SYMBOL (TIME) TO (TIME)*
R7-9A	NO PARKING SYMBOL BIKE LANE
R7-2	NO PARKING XXXX TO XXXX *
R4-901	NO PASSING ON BRIDGE
W14-3	NO PASSING ZONE
R9-3	NO PEDESTRIAN CROSSING
R9-3A	NO PEDESTRIAN CROSSING SYMBOL
R3-1	NO RIGHT TURN SYMBOL
R10-11C	(NO RIGHT TURN SYMBOL) ON RED
W8-1801	NO SHOULDER
W10-10	NO SIGNAL
R7-4	NO STANDING ANYTIME _____ ARROW
R8-6	NO STOPPING EXCEPT ON SHOULDERS
R8-5	NO STOPPING ON PAVEMENT
R8-8	NO STOPPING ON TRACKS
R7-402	NO STOPPING OR STANDING
R7-401	NO STOPPING OR STANDING W / ARROW
W10-9	NO TRAIN HORN
R17-2	NO TRESPASSING
R12-3	NO TRUCKS OVER _____ LBS. EMPTY WEIGHT
R5-2	NO TRUCKS SYMBOL
R10-11A	NO TURN ON RED
R10-11B	NO TURN ON RED
R10-11	NO TURN ON RED BALL
R3-3	NO TURNS
R3-4	NO U TURN SYMBOL

* denotes variable message sign

M3-1	NORTH
M3-1B	NORTH
I8-703	NOTICE-PARKING/COMMUTERS ONLY
R16-203	NOV 1 TO APR 1/EXCEPT ALL-WHEEL DRIVE
R8-3D	ON BRIDGE
R8-3C	ON PAVEMENT
W13-4	ON RAMP
R10-1404	ONE CAR PER GREEN
R10-1403	1 CAR PER GREEN EACH LANE
R10-1405	ONE CAR PER GREEN EACH LANE
R10-1402	1 CAR PER GREEN THIS LANE
D1-101	1 DESTINATION W/ARROW*
R7-5	ONE HOUR PARKING (TIME) TO (TIME)*
W1-901L	180 DEGREE CURVE LEFT
W1-901R	180 DEGREE CURVE RIGHT
W5-3	ONE LANE BRIDGE
W20-4	ONE LANE ROAD AHEAD
R12-1101	ONE TRUCK AT A TIME ON BRIDGE
R10-701	ONE VEHICLE IN MEDIAN AT A TIME
R6-1 L	ONE WAY (LEFT)
R6-2 L	ONE WAY (LEFT)
R6-1 R	ONE WAY (RIGHT)
R6-2 R	ONE WAY (RIGHT)
D8-202	OPEN - CLOSED PANEL
R7-10802	PARALLEL PARKING ONLY
D4-301	PARK & RIDE _____*
D4-2	PARK & RIDE*
E13-1	PARK AND RIDE NEXT RIGHT*
E13-2	PARK AND RIDE W/EXIT NUMBER*
R4-2	PASS WITH CARE
R4-601	PASSING LANE _____ MILES
W8-3	PAVEMENT ENDS
W8-2201	PAVEMENT RUTS
W4-2L	PAVEMENT WIDTH TRANSITION LEFT
W4-2R	PAVEMENT WIDTH TRANSITION RIGHT
R9-8	PEDESTRIAN CROSSWALK
M4-9B	PEDESTRIAN DETOUR
R5-10B	PEDESTRIANS AND BICYCLES PROHIBITED
R5-10C	PEDESTRIANS PROHIBITED
R5-1002	PEDESTRIANS, HITCHHIKERS, BICYCLES PROHIBITED
	PEDESTRIANS, HITCHHIKERS, BICYCLES, AND MOTORIZED FOOT
R3-1004	SCOOTERS PROHIBITED
R5-1001	PEDESTRIANS, HITCHHIKERS, PROHIBITED
W11A-501	PEDESTRIANS/BICYCLES
R5-10A	PEDS, BICYCLES, MOTOR-DRIVEN CYCLES PROHIBITED
W7-3	_____ % GRADE
W7-3B	_____ % GRADE _____ MILES

* denotes variable message sign

D5-801	PET AREA DIRECTIONAL
D5-901	PET AREA KEEP PETS ON LEASH
D9-1	PHONE SYMBOL (Informational)
D9-1	PHONE SYMBOL (Recreational)
R10-19	PHOTO ENFORCED
W16-10	PHOTO ENFORCED
G20-4	PILOT CAR FOLLOW ME
P-4	PIT SITE
P-6	PIT SIZE/MILES*
I9-101	PLAYGROUND
W15-1	PLAYGROUND (SYMBOL)
I20-201	PLEASE DON'T DRINK AND DRIVE
I8-702	PLEASE LIMIT YOUR STAY TO 8 HOURS NO TENTS OR CAMPS
D9-14	POLICE
I7-701	PRIMITIVE ROAD NO WARNING SIGNS
D3-104	PRIVATE ROAD NAME SIGN
E6-2	PULL THRU SIGN (OVERHEAD)*
R10-3	PUSH BUTTON FOR GREEN LIGHT
R10-4	PUSH BUTTON FOR WALK SIGNAL
R10-4001	PUSH BUTTON FOR WALK SIGNAL-DIRECTIONAL ARROW LEFT
R10-4002	PUSH BUTTON FOR WALK SIGNAL-DIRECTIONAL ARROW RIGHT
R15-1	R/R CROSSING(CROSS BUCK)
W10-1	RAILROAD ADVANCE SIGN
W13-3	RAMP _____ MPH
R11-201	RAMP CLOSED
W3-501	RAMP METERING AHEAD WHEN FLASHING
R11-1501	RAMP WILL BE CLOSED _____ EXIT WILL BE CLOSED _____
I2-401	RANGE AREA WATCH OUT FOR LIVESTOCK
D7-7701	REC AREA NEXT RIGHT
LG-C3	RECREATION (CONVENTIONAL ROADS)*
LG-M8	RECREATION (FREEWAY DOUBLE EXIT)*
LG-R2	RECREATION (RAMPS)*
LG-M7	RECREATION NEXT RIGHT (FREEWAY)*
D7-101	RECREATIONAL AREA ADVANCE SIGN
D7-201	RECREATIONAL AREA DIRECTIONAL SIGN
I20-101	REPORT DRUNK DRIVING
R7-801	RESERVED PARKING (DISABLED LOGO)
D5-201	REST AREA (ARROW _____ DEGREES) (MAJOR)
D5-701	REST AREA (ARROW _____ DEGREES) (MINOR)
D5-101	REST AREA ____ MILES
D5-601	REST AREA ADVANCE (MINOR)
D5-103	REST AREA NEXT RIGHT
D4-401	REST AREA PARKING*
D5-204	REST AREA VISITOR INFO CENTER (ARROW _____ DEGREES)
D5-202	REST AREA VISITOR INFORMATION CENTER ____ MILES
D5-203	REST AREA VISITOR INFORMATION CENTER NEXT RIGHT
R3-10	RESTRICTED LANE AHEAD

* denotes variable message sign

R3-13	RESTRICTED LANE AHEAD
R3-12	RESTRICTED LANE ENDS
R3-15	RESTRICTED LANE ENDS
R3-1203	RESTRICTED LANE EXIT ONLY
R7-108	RESTRICTED PARKING XXXX TO XXXXX *
W1-4L	REVERSE CURVE LEFT
W1-4R	REVERSE CURVE RIGHT
W1-3L	REVERSE TURN LEFT
W1-3R	REVERSE TURN RIGHT
R9-3C	RIDE WITH TRAFFIC
R3-17	RIGHT LANE (BIKE SYMBOL) ONLY
R3-1103R	RIGHT LANE (BUS & ____ CARPOOL SYMBOLS) ONLY, MOTORCYCLES OK
R3-2005	RIGHT LANE (BUS & ____ PERSON CARPOOL SYMBOL) EXCEPT RIGHT TURNS
R3-1104R	RIGHT LANE (BUS & ____ PERSON CARPOOL SYMBOLS) ARROW
R3-2001	RIGHT LANE BUSES ONLY
W9-1R	RIGHT LANE ENDS
R3-701	RIGHT LANE MUST EXIT
R3-7R	RIGHT LANE MUST TURN RIGHT
R3-2004	RIGHT LANE TRANSIT ONLY EXCEPT RIGHT TURNS
R10-17A	RIGHT ON RED ARROW AFTER STOP
W20-303	RIGHT SHOULDER CLOSED
W1-1R	RIGHT TURN
R3-702	RIGHT TURN PERMITTED WITHOUT STOPPING
R10-10R	RIGHT TURN SIGNAL
W20-501	RIGHT TWO LANES CLOSED AHEAD
W20-5	RIGHT/LEFT LANE CLOSED AHEAD*
R11-2	ROAD CLOSED
R11-3	ROAD CLOSED _____ MILES AHEAD LOCAL TRAFFIC ONLY
R11-4	ROAD CLOSED TO THRU TRAFFIC
W21-3	ROAD MACHINERY AHEAD
W5-1	ROAD NARROWS
W20-1	ROAD WORK AHEAD
G20-1	ROAD WORK NEXT _____ MILES
W20-3	ROAD/STREET/RAMP CLOSED AHEAD*
W8-1701	ROCKS
W8-8	ROUGH ROAD
W2-6	ROUNDAABOUT AHEAD (SYMBOL)
W2-6P	ROUNDAABOUT AHEAD PLAQUE
M8-101	ROUTE MARKER ASSEMBLY W/ARROW*
M8-201	ROUTE MARKER ASSEMBLY W/ARROWS*
M8-301	ROUTE MARKER ASSEMBLY W/ARROWS*
M8-401	ROUTE MARKER ASSEMBLY W/TWO SHIELDS*
R3-1102R	RT LANE (BUS & ____ CARPOOL SYMBOLS) ONLY ____ AM - ____ PM
W7-4	MOTORCYCLES OK
W7-4A	RUNAWAY TRUCK RAMP _____ MILE
R4-10	RUNAWAY TRUCK RAMP ARROW _____ DEGREES
	RUNAWAY VEHICLES ONLY

* denotes variable message sign

D9-301	RV PARK SIGN
I4-401	SCENIC AND RECREATIONAL HIGHWAY MARKER
D6-2	SCENIC AREA ADVANCE SIGN
D6-3	SCENIC AREA EXIT DIRECTION
D6-1	SCENIC AREA W/ARROW
S4-3	SCHOOL
S1-1	SCHOOL ADVANCE SIGN
S3-1	SCHOOL BUS STOP AHEAD
S3-201	SCHOOL BUS TURNAROUND
	SCHOOL DAYS ____AM - ____PM or (5A) ____AM - ____AM & ____PM -
S4-5 & 5A	____PM
S5-101	SCHOOL SPEED LIMIT 20 WHEN CHILDREN ARE PRESENT
S5-1	SCHOOL SPEED LIMIT 20 WHEN FLASHING
W14-801	SEVERE SIDE WIND AHEAD
W20-301	SHOULDER CLOSED
W21-701	SHOULDER DROP-OFF
W21-5	SHOULDER WORK
W10-3	SIDE ROAD RAILROAD SIGN _____
W2-2	SIDE ROAD SYMBOL
W2-3	SIDE ROAD SYMBOL 45 DEGREES
R9-9	SIDEWALK CLOSED
R9-10	SIDEWALK CLOSED (DOUBLE HEADED ARROW) USE OTHER SIDE
R9-11A	SIDEWALK CLOSED (SINGLE HEAD ARROW) CROSS HERE
R9-11	SIDEWALK CLOSED AHEAD (SINGLE HEAD ARROW) CROSS HERE
W3-3	SIGNAL AHEAD (SYMBOL)
W20-903	SIGNAL REVISION AHEAD
I1-1	SIGNALS SET FOR ____ MPH
W10-12	SKewed CROSSING
W8-1901	SLIDE AREA
W8-10	SLIPPERY WHEN WET (BICYCLE SYMBOL)
W8-5	SLIPPERY WHEN WET SYMBOL
W14-601	SLOW MOVING VEHICLE
W14-901	SLOW MOVING VEHICLE (SYMBOL)
I8-301	SLOW VEHICLE TURNOUT (ARROW _____ DEGREES)
I8-401	SLOW VEHICLE TURNOUT _____
I8-501	SLOW VEHICLES MAY USE SHOULDER
I8-101	SLOW VEHICLES USE TURNOUTS NEXT _____ MILES
R4-3	SLOWER TRAFFIC KEEP RIGHT
W11-6	SNOWMOBILE CROSSING
W8-4	SOFT SHOULDER
M3-3	SOUTH
M3-3B	SOUTH
W17-1	SPEED HUMP
R2-1	SPEED LIMIT _____
R2-4A	SPEED LIMIT _____ MINIMUM _____
W3-5	SPEED LIMIT REDUCTION AHEAD
I30-101	SPEEDOMETER CHECK SECTION AHEAD
I20-204	SPONSORED BY THE _____ FAMILY
D10-501	SPUR ROUTE PLAQUE

R7-801P	STATE DISABLED PARKING PERMIT REQUIRED
I8-901	STATE LAW ALL VEHICLES MUST KEEP TO RIGHT EXCEPT TO PASS
I8-1001	STATE LAW-MOTORCYCLISTS MUST WEAR HELMETS
M1-601	STATE ROUTE _____
M1-701	STATE ROUTE _____ (DIRECTIONAL)
M1-602	STATE ROUTE _____ (GUIDE SIGN USE)
R4-9	STAY IN LANE
P-5	STOCK PILE _____ MILES
P-3	STOCKPILE
R1-1	STOP
W3-1	STOP AHEAD
W3-1A	STOP AHEAD (SYMBOL)
R10-6A	STOP HERE ON RED CURVED ARROW
R10-6L	STOP HERE ON RED DIRECTIONAL ARROW
R10-6R	STOP HERE ON RED DIRECTIONAL ARROW
R10-601L&R	STOP HERE ON RED DIRECTIONAL ARROW 1 CAR PER GREEN
I3-101	STREAM NAME SIGN*
D3-401	STREET NAME SIGN W/GEORGE SHIELD*
D3-101	STREET NAME SIGN*
I3-201	SUMMIT ELEVATION SIGN*
R10-20B	SUNDAY _____ AM
W16-5PR	SUPPLEMENTAL ARROW 270 PLAQUE (RIGHT)
W16-5PL	SUPPLEMENTAL ARROW 90 PLAQUE (LEFT)
W21-6	SURVEY CREW
D7-401	SYMBOL - BICYCLE TRAIL
D7-1101	SYMBOL - BOAT LAUNCH
D7-1201	SYMBOL - BOAT MOORAGE
D7-1001	SYMBOL - BOATING
D7-601	SYMBOL - BRIDLE TRAIL
D7-2204	SYMBOL - CAMPFIRE
D7-1601	SYMBOL - CANOEING
D7-801	SYMBOL - CLIMBING
D9-13	SYMBOL - EMERGENCY MEDICAL SERVICES
D7-1301	SYMBOL - FISHING
D9-8	SYMBOL - FOOD
I1-201	SYMBOL - FOREST FIRE PREVENTION
D9-11A	SYMBOL - FUEL, COMPRESSED NATURAL GAS
D9-1101	SYMBOL - FUEL, DIESEL
D9-11B	SYMBOL - FUEL, ETHANOL
D9-11	SYMBOL - FUEL, GASOLINE
D7-701	SYMBOL - GOLFING
D9-6	SYMBOL - HANDICAPPED
D9-2	SYMBOL - HOSPITAL
D5-904	SYMBOL - INFORMATION
D5-903	SYMBOL - LIGHTHOUSE
D9-9	SYMBOL - LODGING
D9-15	SYMBOL - LP GAS
D5-906	SYMBOL - PET AREA KEEP PETS ON LEASH

* denotes variable message sign

D7-2201	SYMBOL – PICNICKING
D7-2203	SYMBOL - PLAYGROUND
D9-1301	SYMBOL - QUESTION MARK
D5-902	SYMBOL - RANGER STATION
D9-12	SYMBOL - RECREATIONAL VEHICLE SANITARY STATION
D5-908	SYMBOL - REST ROOM
D9-4	SYMBOL - RESTROOM MEN
D9-5	SYMBOL - RESTROOM WOMEN
D9-7	SYMBOL - RESTROOM WOMEN AND MEN
D7-1701	SYMBOL - ROWBOATING
D9-10	SYMBOL - SHOWERS
D7-2001	SYMBOL - SNOW SKIING
D7-2101	SYMBOL - SNOWMOBILE AREA
D7-2104	SYMBOL - SNOWSHOEING
D7-1401	SYMBOL - SWIMMING
D9-3	SYMBOL - TENT CAMPING
D7-501	SYMBOL - TRAIL
D7-901	SYMBOL - TRAIL (INTERPRETIVE PED)
D9-3B	SYMBOL - TRAILER AND TENT CAMPING
D9-3A	SYMBOL - TRAILER CAMPING
D5-905	SYMBOL - VIEWPOINT
D5-907	SYMBOL - WATCHABLE WILDLIFE (BINCOULAR)
D7-1501	SYMBOL - WATER SKIING
D9-1B	SYMBOL ADVANCE PHONE _____ MILE
D7-2002	SYMBOL- CROSS COUNTRY SKIING
D9-1A	SYMBOL PHONE (ARROW _____ DEGREES)
D7-2103	SYMBOL- WINTER SPORTS
W2-4	T (SYMBOL)
W10-4	T SYMBOL RAILROAD SIGN
M4-7	TEMPORARY
M4-7A	TEMPORARY, BLACK ON WHITE
M4-7B	TEMPORARY, WHITE ON BLUE
G28-201	THANK YOU – WSDOT & (CONTRACTOR’S NAME)
D1-301	3 DESTINATIONS W/ARROWS*
I6-301	THROWING AWAY BURNING MATERIAL PROHIBITED
D5-301	TIRED? REST AREA _____ MILES
M4-5	TO
M4-5B	TO
M4-13	TO
S4-1	_____ TO _____
M4-1301	TO (BICYCLE ROUTE)
R10-3A	TO CROSS STREET PUSH BUTTON - WAIT FOR GREEN LIGHT
R10-4A	TO CROSS STREET PUSH BUTTON WAIT FOR WALK SIGNAL
R1-2A	TO ONCOMING TRAFFIC
R10-22	TO REQUEST GREEN WAIT ON BICYCLIST SYMBOL
LG-C2	TOURIST ACTIVITIES (CONVENTIONAL ROADS)*
LG-M10	TOURIST ACTIVITIES (FREEWAY DOUBLE EXIT)*

* denotes variable message sign

LG-R3	TOURIST ACTIVITIES (RAMP)*
LG-M9	TOURIST ACTIVITIES EXIT XXX (FREEWAY)*
LG-M9A	TOURIST ACTIVITIES EXIT XXX, VERTICAL PANEL (FREEWAY)*
R7-201	TOW-AWAY ZONE
R7-201A	TOW-AWAY ZONE SYMBOL
R15-2	_____ TRACKS
R8-9	TRACKS OUT OF SERVICE
R16-2103	TRACTION ADVISORY OVERSIZED VEHICLES PROHIBITED
I20-301	TRAFFIC FINES DOUBLE IN WORK ZONES
R10-18	TRAFFIC LAWS PHOTO ENFORCED
W20-901	TRAFFIC REVISION AHEAD
W24-101	TRAFFIC SURVEY AHEAD
I5-7	TRAIN STATION (SYMBOL)
R3-2002	TRANSIT (BUS SYMBOL) ONLY
R3-1502	TRANSIT LANE ENDS
R3-1503	TRANSIT LANE ENDS _____ MILES
R3-2003	TRANSIT ONLY ARROW 315
W14-1101	TRANSIT STOP AHEAD (SYMBOL)
I35-102	TRAVELER INFO DIAL 511
I35-101	TRAVELER INFO TUNE _____ AM TRAFFIC ADVISORY WHEN FLASHING
M4-4	TRUCK
W8-6	TRUCK CROSSING
W11-10	TRUCK CROSSING (SYMBOL)
W7-4B	TRUCK ESCAPE RAMP
W7-	
4C,D,&E	TRUCK ESCAPE RAMP PLAQUES, SAND, GRAVEL, & PAVED
R4-6	TRUCK LANE _____ FEET
R14-5	TRUCK PROHIBITED SYMBOL
R14-1	TRUCK ROUTE
R14-4	TRUCK SYMBOL
R2-2	TRUCKS _____
W21-30	TRUCKS ENTERING HIGHWAY
W21-30A	TRUCKS LEAVING HIGHWAY
R13-201	TRUCKS OVER 10, 000 GVWR STOP AT SCALES WHEN OPEN
R13-302	TRUCKS OVER 10,000 GVWR STOP AT SCALES/WEIGH STATION CLOSED
R4-302A	TRUCKS OVER 10,000 LBS USE RIGHT _____ LANES ONLY
R13-301	TRUCKS STOP AT SCALES/WEIGH STATION CLOSED
W7-2B	TRUCKS USE LOWER GEAR
R4-5	TRUCKS USE RIGHT LANE
I25-101	TSUNAMI EVACUATION ROUTE
I25-102	TSUNAMI WARNING
W14-501	TUNNEL
W22-2	TURN OFF 2-WAY RADIO AND CELLULAR PHONES
I7-501	TURN ON LIGHTS
R10-15	TURNING TRAFFIC MUST YIELD TO PEDESTRIANS
R10-1401	TWO CARS PER GREEN
W1-4BR	2 CURVE RIGHT ARROWS

* denotes variable message sign

D1-201	2 DESTINATIONS W/ARROWS*
W1-15	270 DEGREE LOOP
W1-4CR	3 CURVE RIGHT ARROWS
R3-9A	(TWO WAY LEFT TURN)ONLY (OVERHEAD MOUNTED)
W6-3	TWO WAY TRAFFIC (SYMBOL)
M1-4	U.S. _____
M1-4A	U.S. _____ (GUIDE SIGN USE)
M1-401	U.S. _____ (DIRECTIONAL)
W8-11	UNEVEN LANES
R4-605	UNMUFFLED COMPRESSION BRAKES PROHIBITED
D4-1	URBAN PUBLIC PARKING SIGN
G24-101	USE ALL LANES
R9-3BL	USE CROSSWALK (ARROW LEFT)
R9-3BR	USE CROSSWALK (ARROW RIGHT)
R10-8	USE LANE WITH GREEN ARROW
G24-201	USE LEFT LANE
R4-604	USE OF COMPRESSION BRAKES PROHIBITED
G24-301	USE RIGHT LANE
R3-703	USE RIGHT LANE TO EXIT
R16-101	USE RIGHT SHOULDER TO INSTALL CHAINS
R16-102	USE RIGHT SHOULDER TO REMOVE CHAINS
I1-2	USE YOUR ASHTRAY
R10-16	U-TURN YIELD TO RIGHT TURN
R7-801A	VAN ACCESSIBLE
I1-301	VEGETATION MANAGEMENT APPLICATION
R16-501A	VEHICLES OVER 10,000 GVW USE CHAINS WHEN TRAC. TIRES REQ.
R16-2101	VEHICLES OVER 10,000 GVWR CHAINS REQUIRED
R16-501	VEHICLES OVER 10,000 LBS GROSS MUST USE CHAINS
R5-5	VEHICLES WITH LUGS PROHIBITED
R4-302	VEHICLES WITH TRAILERS OR OVER 10,000 LBS PROHIBITED IN LEFT LANE VEHICLES WITH TRAILERS OR OVER 10,000 LBS USE RIGHT ____ LANES
R4-302B	ONLY
I25-201	VOLCANO EVACUATION ROUTE
R9-1	WALK ON LEFT FACING TRAFFIC
W8-1601	WATCH FOR ICE
W8-1501	WATER OVER ROADWAY
I8-709	WATER UNSAFE TO DRINK
D8-1	WEIGH STATION ____ MILE
D8-301	WEIGH STATION EXIT (ARROW _____ DEGREES)
D8-201	WEIGH STATION RIGHT LANE
R12-1	WEIGHT LIMIT ____ TONS
R12-4	WEIGHT LIMIT _____ TONS PER AXLE _____ TONS GROSS
R12-5	WEIGHT LIMIT TRUCK SYMBOLS W/WEIGHT*
R12-501	WEIGHT RESTRICTIONS IN FORCE
I2-101	WELCOME TO WASHINGTON
M3-4	WEST
M3-4B	WEST

* denotes variable message sign

S4-2	WHEN CHILDREN ARE PRESENT
S4-501	WHEN FLAGGED
S4-4	WHEN FLASHING
W1-5L	WINDING ROAD LEFT
W1-5R	WINDING ROAD RIGHT
W21-1A	WORK CREW (SYMBOL)
G28-101	WORK ZONE AHEAD; GIVE'EM A BRAKE
R5-1A	WRONG WAY
W2-5	Y (SYMBOL)
R1-2	YIELD
W3-2A	YIELD AHEAD (SYMBOL)
R1-5L&R	YIELD HERE TO PEDESTRIANS

APPENDICES

- Appendix A Sign Sizing, Layout, and Spacing
- Appendix B Guide Sign Arrows
- Appendix C Letter Spacing for Upper and Lower Case
- Appendix D Graphics Templates
- Appendix E Express Lane Gate Arm

D1-601 & D1-602 & D1-603

1/06

D1-601



D1-602



D1-603



* SEE APPENDIX FOR STANDARD ARROW DETAILS

DIMENSIONS (MILLIMETERS)			
SIZE CODE	LETTER SIZE		BORDER WIDTH
	U.C.	L.C.	
A	200	150	38
B	265	200	38
C	333	250	50
D	400	300	50

DIMENSIONS (INCHES)			
SIZE CODE	LETTER SIZE		BORDER WIDTH
	U.C.	L.C.	
A	8	6	1 1/2
B	10.6	8	1 1/2
C	13.3	10	2
D	16	12	2

COLORS

LEGEND — WHITE (REFL)
 BACKGROUND — GREEN (REFL)
 BACKGROUND — BROWN (REFL)
 (Brown, National or State Parks Only)

D1-701

5/06



* SEE APPENDIX FOR STANDARD ARROW DETAILS

DIMENSIONS (MILLIMETERS)						
SIZE CODE	A	B	C	D	E	F
A	200EM	450	38	200E/150E	150EM	1 OR 2
B	265EM	600	38	250E/200E	200EM	3 OR 4
C	333EM	900	50	300E/250E	250EM	3 OR 4
D	400EM	900	50	375E/300E	300EM	5 OR 6

DIMENSIONS (INCHES)						
SIZE CODE	A	B	C	D	E	F
A	8EM	18	1 1/2	8E/6E	6EM	1 OR 2
B	10.6EM	24	1 1/2	10E/8E	8EM	3 OR 4
C	13.3EM	36	2	12E/10E	10EM	3 OR 4
D	16EM	36	2	15E/12E	12EM	5 OR 6

WHITE ON BROWN MAY BE SPECIFIED ON THE PLANS FOR RECREATIONAL SIGNING. HOWEVER, BROWN SHALL NOT BE USED WITH A NUMBERED HIGHWAY ROUTE DESIGNATION ON THE SIGN.

COLORS

LEGEND — WHITE (REFL)
BACKGROUND — GREEN (REFL)

D1-801 & D1-901

12/05

D1-801



D1-901



* SEE APPENDIX FOR STANDARD ARROW DETAILS

DIMENSIONS (MILLIMETERS)								
SIZE CODE	LETTER SIZE		CARDINAL DIRECTION	SHIELD SIZE	VERTICAL DIMENSION		BORDER WIDTH	ARROW SIZE
	U.C.	L.C.			D1-801	D1-901		
A	200	150	200E/150E	450	2400	1200	38	1
B	265	200	250E/200E	600	3000	1500	50	3

DIMENSIONS (INCHES)								
SIZE CODE	LETTER SIZE		CARDINAL DIRECTION	SHIELD SIZE	VERTICAL DIMENSION		BORDER WIDTH	ARROW SIZE
	U.C.	L.C.			D1-801	D1-901		
A	8	6	8E/6E	18	96	48	1 1/2	1
B	10.6	8	10E/8E	24	120	60	2	3

COLORS

LEGEND — WHITE (REFL)
BACKGROUND — GREEN (REFL)

D3-101

10/97



DIMENSIONS (MILLIMETERS)					
A	B	C	D	E	F
VA	200	16	75D	100D	38
VA	300	22	100D	150D	56
VA	400	31	150D	200D	75

DIMENSIONS (INCHES)					
A	B	C	D	E	F
VA	8	5/8	3D	4D	1 1/2
VA	12	7/8	4D	6D	2 1/4
VA	16	1 1/4	6D	8D	3

COLORS

LEGEND — WHITE (REFL)
 BACKGROUND — GREEN (REFL)

D3-102

12/05



DIMENSIONS (MILLIMETERS)			
A	B	C	D
VAR	150	100D	50D
VAR	225	150C	100C
VAR	300	200C	150C

DIMENSIONS (INCHES)			
A	B	C	D
VAR	6	4D	2D
VAR	9	6C	4C
VAR	12	8C	6C

COLORS

LEGEND — WHITE (REFL)
BACKGROUND — GREEN (REFL)

D3-103

10/00

DOUBLE FACED STREET NAME SIGN



NOTE: 4" MOUNTING AREA IS GREEN REFLECTIVE SHEETING

DIMENSIONS (MILLIMETERS)				
A	B	C	D	E
VAR	400	19	150D	38

DIMENSIONS (INCHES)				
A	B	C	D	E
VAR	16	3/4	6D	1 1/2

COLORS

LEGEND — WHITE (REFL)
BACKGROUND — GREEN (REFL)

D3-104

12/05

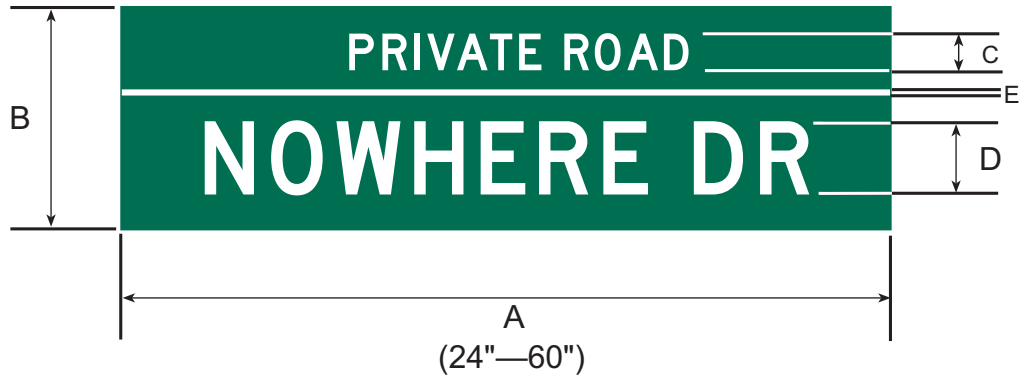

DIMENSIONS (MILLIMETERS)				
A	B	C	D	E
VAR	300	50D	150C	16

DIMENSIONS (INCHES)				
A	B	C	D	E
VAR	12	2D	6C*	5/8

* 6C PREFERRED, 6B ALLOWED IF NECESSARY

COLORS

LEGEND, SEPARATION BAR—WHITE (REFL)

BACKGROUND—GREEN (REFL)

D3-2

1/06

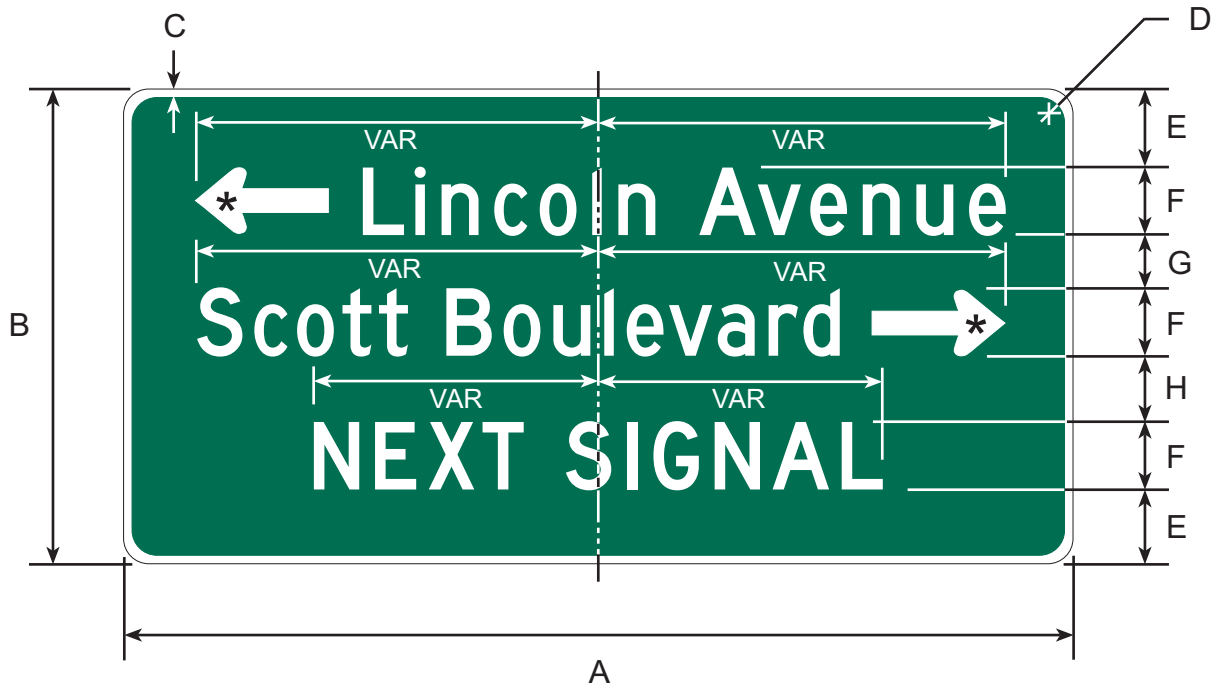

* SEE APPENDIX FOR STANDARD ARROW DETAILS

DIMENSIONS (MILLIMETERS)							
A	B	C	D	E	F	G	H
VAR	1050	19	56	175	150D	100	150
VAR	1350	25	75	163	150D	100	113

DIMENSIONS (INCHES)							
A	B	C	D	E	F	G	H
VAR	42	3/4	2 1/4	7	6D	4	6
VAR	54	1	3	6 1/2	6D	4	4 1/2

COLORS

LEGEND - WHITE (REFL)
BACKGROUND - GREEN (REFL)

D3-2A

1/06

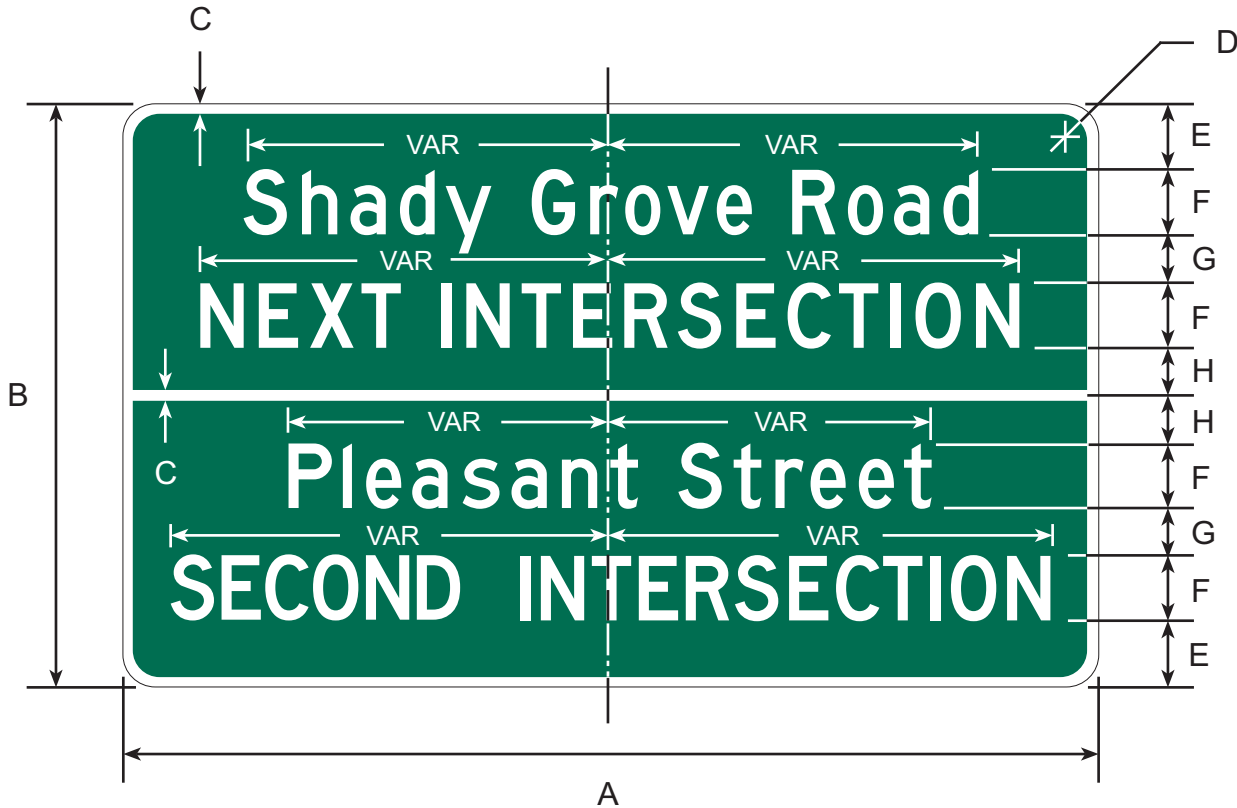

DIMENSIONS (MILLIMETERS)							
A	B	C	D	E	F	G	H
VAR	1350	25	75	150	150D	113	113

DIMENSIONS (INCHES)							
A	B	C	D	E	F	G	H
VAR	54	1	3	6	6D	4 1/2	4 1/2

COLORS

LEGEND - WHITE (REFL)
 BACKGROUND - GREEN (REFL)

D3-201

12/05



NOTE: SERIES C LETTERS MAY BE USED WHEN SPECIFIED ON THE PLANS

DIMENSIONS (MILLIMETERS)		
A	B	C
VAR	150	100D
VAR	225	125D
VAR	300	150D
VAR	400	200D

DIMENSIONS (INCHES)		
A	B	C
VAR	6	4D
VAR	9	5D
VAR	12	6D
VAR	16	8D

COLORS

LEGEND — BLACK (NON-REFL)
BACKGROUND — YELLOW (REFL)

D3-301

12/05

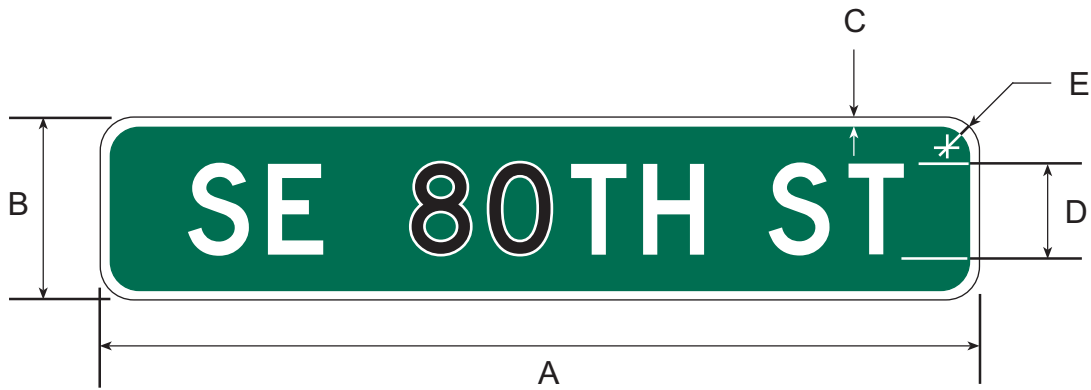

DIMENSIONS (MILLIMETERS)				
A	B	C	D	E
VAR	300	19	150D	38
VAR	400	19	200D	38

DIMENSIONS (INCHES)				
A	B	C	D	E
VAR	12	3/4	6D	1 1/2
VAR	16	3/4	8D	1 1/2

COLORS

LEGEND — WHITE (REFL)
BACKGROUND — GREEN (REFL)

D3-302

12/05



DIMENSIONS (MILLIMETERS)							
	A	B	C	D	E	F	G
1 LINE	VAR	300	19	150D	38	45°	150
1 LINE	VAR	400	19	200D	38	45°	200
2 LINES	VAR	600	19	150D	38	45°	200
2 LINES	VAR	750	19	200D	38	45°	200

DIMENSIONS (INCHES)							
	A	B	C	D	E	F	G
1 LINE	VAR	12	3/4	6D	1 1/2	45°	6
1 LINE	VAR	16	3/4	8D	1 1/2	45°	8
2 LINES	VAR	24	3/4	6D	1 1/2	45°	8
2 LINES	VAR	30	3/4	8D	1 1/2	45°	8

COLORS

LEGEND — WHITE (REFL)
BACKGROUND — GREEN (REFL)

D3-401

12/05



DIMENSIONS (MILLIMETERS)								
A	B	C	D	SHIELD SIZE	NUM. SIZE & SERIES			E
					1 DIGIT	2 DIGITS	3 DIGITS	
VAR	300	22	150D	181 X 200	150C	125C	100C	56
VAR	450	31	200D	272 X 300	125C	75C	63C	75

DIMENSIONS (INCHES)								
A	B	C	D	SHIELD SIZE	NUM. SIZE & SERIES			E
					1 DIGIT	2 DIGITS	3 DIGITS	
VAR	12	7/8	6D	7 1/4 X 8	6C	5C	4C	2 1/4
VAR	18	1 1/4	8D	10 7/8 X 12	5C	3C	2 1/2C	3

COLORS

LEGEND - WHITE (REFL)
 SHIELD NUMBERS - BLACK (NON-REFL)
 BACKGROUND - GREEN (REFL)

D4-1

10/97



* SEE APPENDIX FOR STANDARD ARROW DETAILS

DIMENSIONS (MILLIMETERS)											
A	B	C	D	E	F	G	H	J	K	L	M
750	600	9	16	375E	113	75E	253	63	225	38	181

DIMENSIONS (INCHES)											
A	B	C	D	E	F	G	H	J	K	L	M
30	24	3/8	5/8	15E	4 1/2	3E	10 1/8	2 1/2	9	1 1/2	7 1/4

COLORS

LEGEND - GREEN (NON REFL)
BACKGROUND - WHITE (REFL)

D4-2

10/97

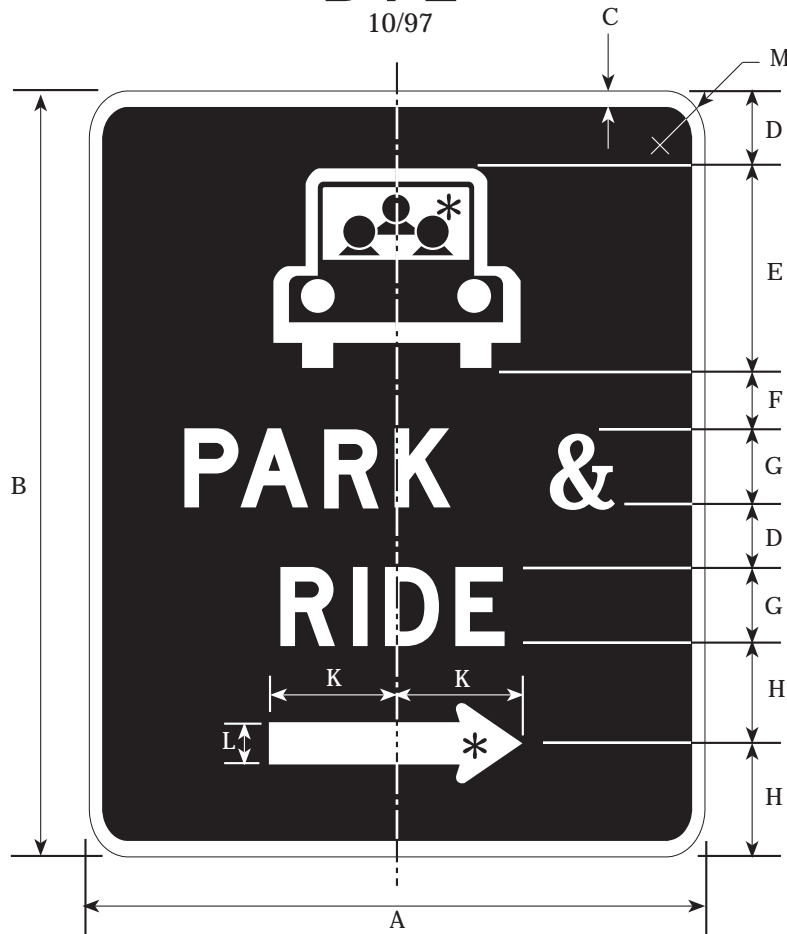

* SEE APPENDIX FOR SYMBOL DESIGN AND STANDARD ARROW DETAILS
CENTER CAR SYMBOL IF NO TRANSIT SYMBOL IS USED

DIMENSIONS (MILLIMETERS)										
A	B	C	D	E	F	G	H	K	L	M
600	750	16	50	200	75	75D	113	150	28	38
750	900	19	75	225	75	100D	125	175	38	47
900	1200	22	100	275	75	150D	175	225	56	56

DIMENSIONS (INCHES)										
A	B	C	D	E	F	G	H	K	L	M
24	30	5/8	2	8	3	3D	4 1/2	6	1 1/8	1 1/2
30	36	3/4	3	9	3	4D	5	7	1 1/2	1 7/8
36	48	7/8	4	11	3	6D	7	9	2 1/4	2 1/4

COLORS

LEGEND, ARROW, & BORDER - WHITE (REFL.)

SYMBOL - WHITE & GREEN (REFL.)

BACKGROUND - GREEN (REFL.)

D4-301

10/97

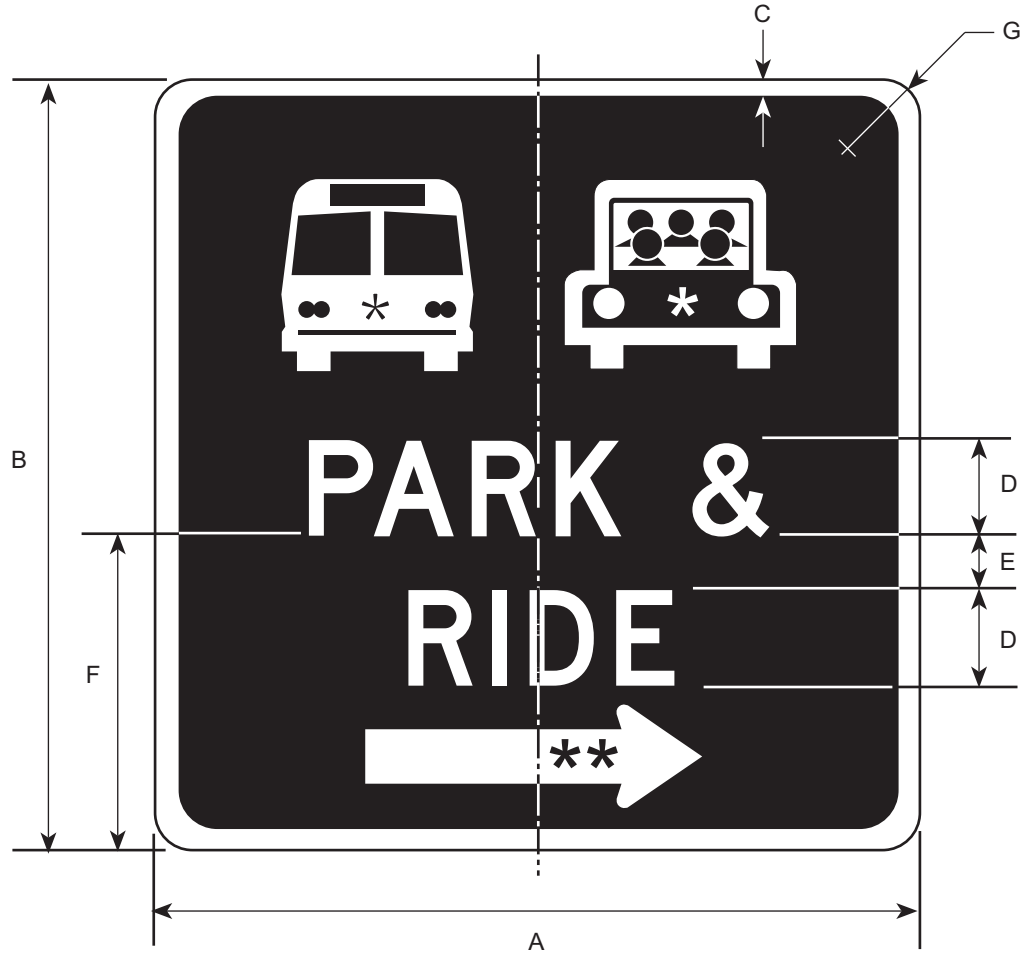

* SEE APPENDIX FOR SYMBOL DESIGN

** SEE APPENDIX FOR ARROW DETAILS

DIMENSIONS (MILLIMETERS)						
A	B	C	D	E	F	G
600	600	16	75D	50	300	38

DIMENSIONS (INCHES)						
A	B	C	D	E	F	G
24	24	5/8	3D	2	12	1 1/2

COLORS

LEGEND — WHITE (REFL)
 BACKGROUND — GREEN (REFL)

D4-401

12/05



* SEE APPENDIX FOR STANDARD ARROW DETAILS

DIMENSIONS (MILLIMETERS)					
A	B	C	ARROW	D	E
1500	1200	19	#2	150D	75
2400	1800	38	#4	200D	225

DIMENSIONS (INCHES)					
A	B	C	ARROW	D	E
60	48	3/4	#2	6D	3
96	72	1 1/2	#4	8D	9

COLORS

LEGEND — WHITE (REFL)
BACKGROUND — GREEN (REFL)

D5-101

10/97

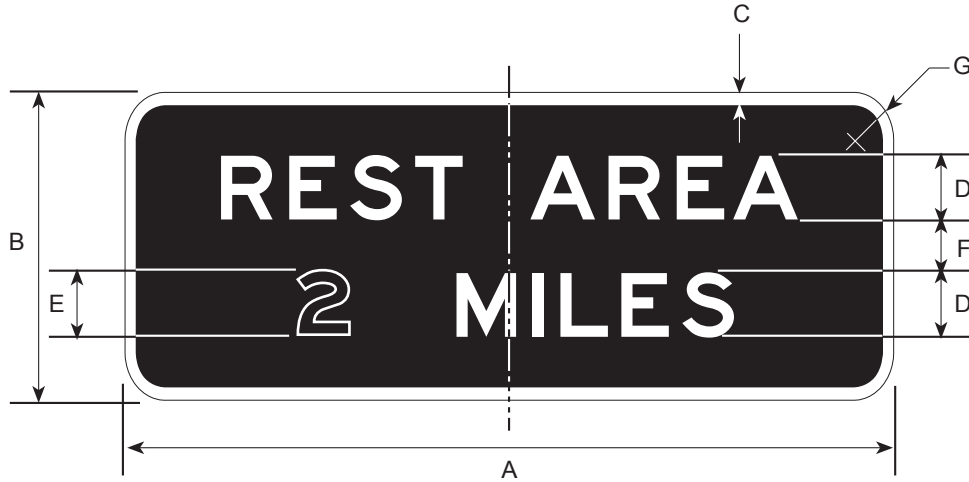

DIMENSIONS (MILLIMETERS)							
A	B	C	D	E	F	G	FRACTION SIZE
2400	900	38	200E	250	138	100	150
3000	1200	50	250E	300	200	150	200
3600	1500	50	300E	375	263	150	250

DIMENSIONS (INCHES)							
A	B	C	D	E	F	G	FRACTION SIZE
96	36	1 1/2	8E	10	5 1/2	4	6
120	48	2	10E	12	8	6	8
144	60	2	12E	15	10 1/2	6	10

COLORS

LEGEND - WHITE (REFL)
 BACKGROUND - BLUE (REFL)

D5-102

6/03



DIMENSIONS (MILLIMETERS)					
A	B	C	D	E	F
2400	600	19	150E	88	75
3000	900	38	200E	113	100

DIMENSIONS (INCHES)					
A	B	C	D	E	F
96	24	3/4	6E	3 1/2	3
120	36	1 1/2	8E	5 1/2	4

COLORS

LEGEND - WHITE (REFL)
 BACKGROUND - BLUE (REFL)

D5-103

10/97

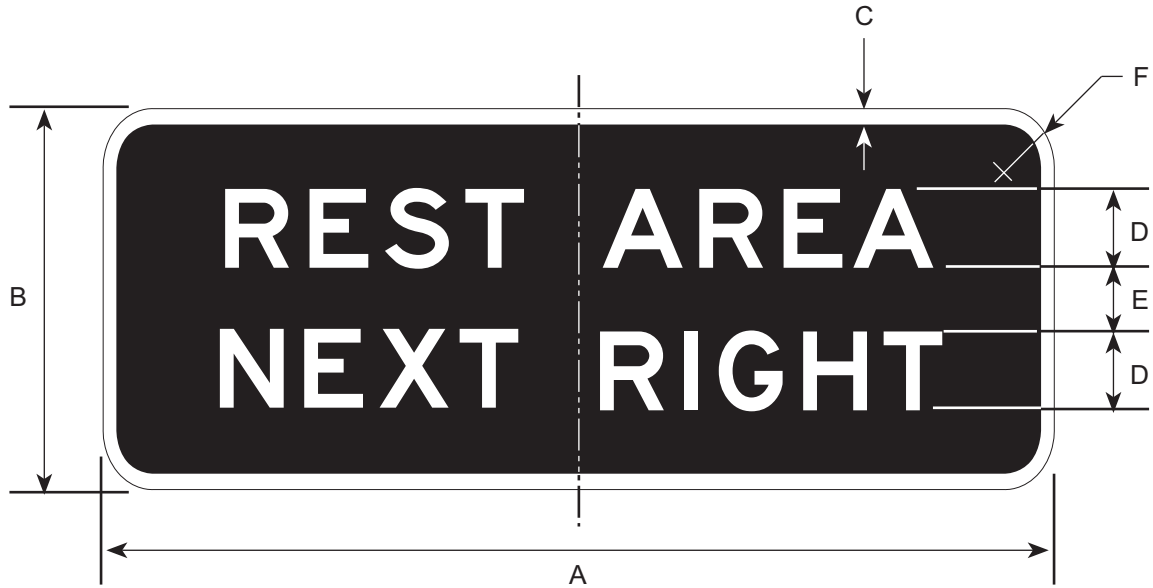

DIMENSIONS (MILLIMETERS)					
A	B	C	D	E	F
2400	900	38	200E	138	100
3000	1200	50	250E	200	150
3600	1500	50	300E	263	150

DIMENSIONS (INCHES)					
A	B	C	D	E	F
96	36	1 1/2	8E	5 1/2	4
120	48	2	10E	8	6
144	60	2	12E	10 1/2	6

COLORS

LEGEND — WHITE (REFL)
 BACKGROUND — BLUE (REFL)

D5-201

12/05

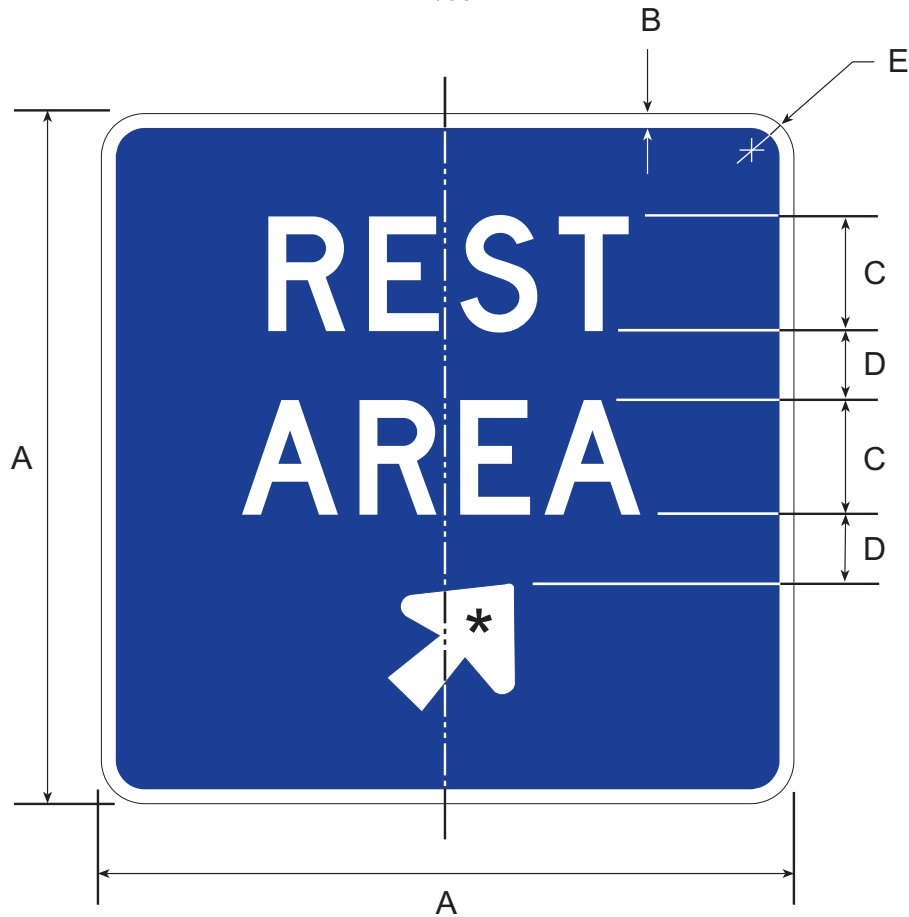

* SEE APPENDIX FOR STANDARD ARROW DETAILS

DIMENSIONS (MILLIMETERS)					
A	B	C	D	E	ARROW SIZE
1200	38	200D	100	100	1
1500	50	250D	125	150	3
1800	50	300D	150	150	5

DIMENSIONS (INCHES)					
A	B	C	D	E	ARROW SIZE
48	1 1/2	8D	4	4	1
60	2	10D	5	6	3
72	2	12D	6	6	5

COLORS

LEGEND — WHITE (REFL)
BACKGROUND — BLUE (REFL)

D5-202

10/97



DIMENSIONS (MILLIMETERS)								
A	B	C	D	E	F	G	H	J
3600	2550	50	300D	225	200	250	375E(M)	250

DIMENSIONS (INCHES)								
A	B	C	D	E	F	G	H	J
144	102	2	12D	9	8	10	15E(M)	10

COLORS

LEGEND - WHITE (REFL)
 BACKGROUND - BLUE (REFL)

D5-203

8/98



EXIT DIRECTION REST AREA - VISITOR
INFORMATION CENTER SIGN (ALTERNATE)

DIMENSIONS (MILLIMETERS)							
A	B	C	D	E	F	G	H
3600	2550	50	300D	225	200	250	250

DIMENSIONS (INCHES)							
A	B	C	D	E	F	G	H
144	102	2	12D	9	8	10	10

COLORS

LEGEND - WHITE (REFL)
BACKGROUND - BLUE (REFL)

D5-204

12/05

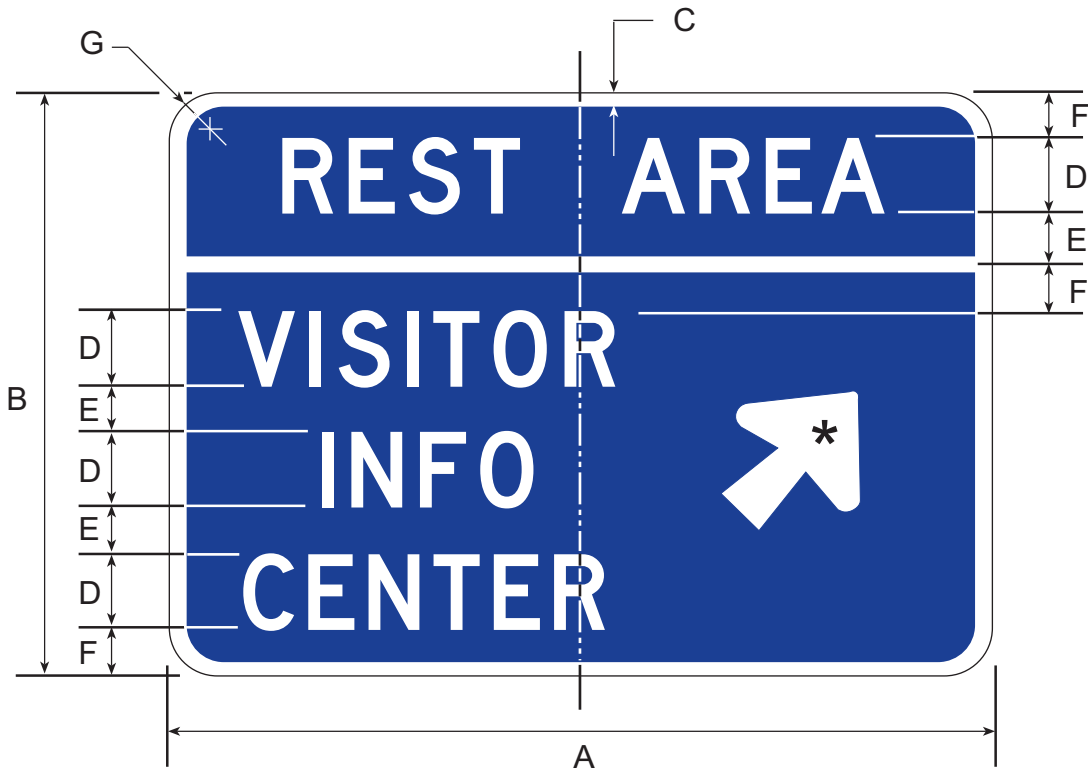

* SEE APPENDIX FOR STANDARD ARROW DETAILS

DIMENSIONS (MILLIMETERS)							
A	B	C	D	E	F	G	ARROW SIZE
3000	2550	50	300D	200	250	250	4

DIMENSIONS (INCHES)							
A	B	C	D	E	F	G	ARROW SIZE
120	102	2	12D	8	10	10	4

COLORS

SYMBOL, LEGEND — WHITE (REFL)
 BACKGROUND — BLUE (REFL)

D5-301

10/97



DIMENSIONS (MILLIMETERS)					
A	B	C	D	E	F
2700	1800	300E	250E	50	225

DIMENSIONS (INCHES)					
A	B	C	D	E	F
108	72	12E	10E	2	9

COLORS

LEGEND— WHITE (REFL)
 BACKGROUND— BLUE (REFL)

D5-901

10/97

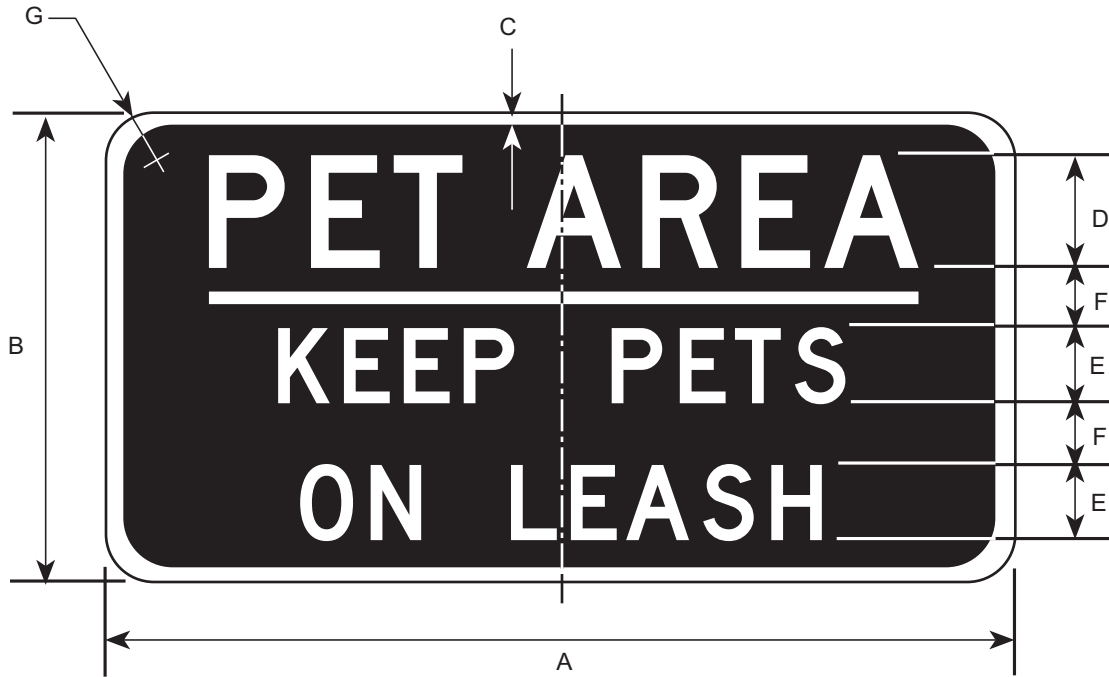

DIMENSIONS (MILLIMETERS)						
A	B	C	D	E	F	G
600	300	13	75D	50D	25	38

DIMENSIONS (INCHES)						
A	B	C	D	E	F	G
24	12	1/2	3D	2D	1	1 1/2

COLORS

LEGEND — WHITE (REFL)
 BACKGROUND — BROWN (REFL)

D6-1

12/05

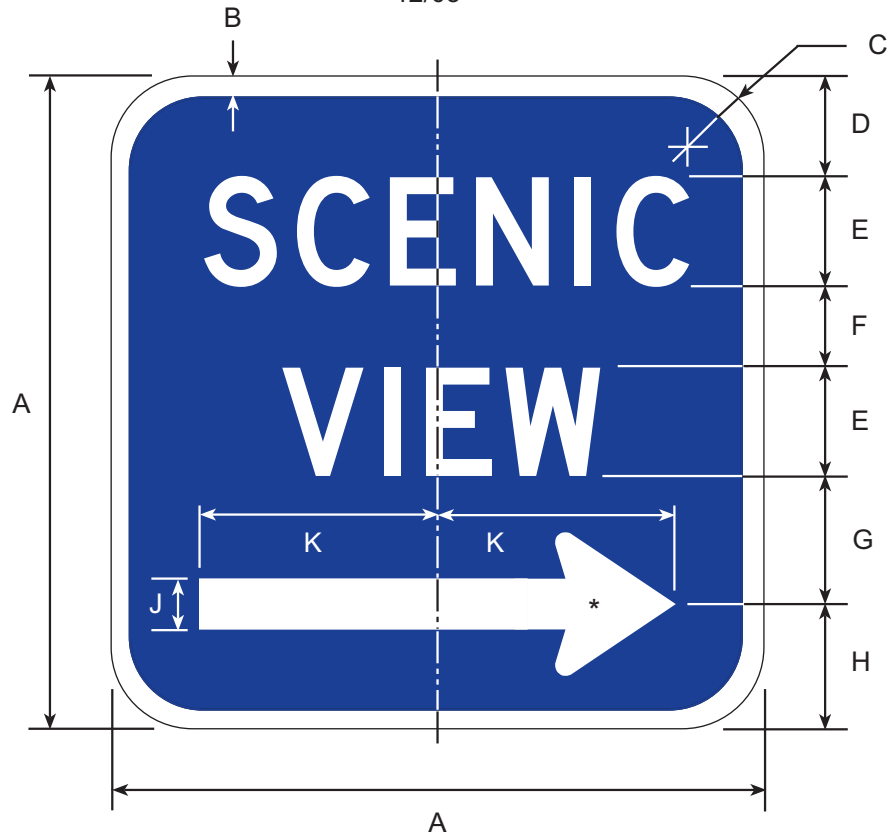

* SEE APPENDIX FOR ARROW DETAILS

DIMENSIONS (MILLIMETERS)									
A	B	C	D	E	F	G	H	J	K
900	25	100	125	150D	110	175	190	69	338
1200	38	150	175	200D	150	225	250	88	450
1500	50	150	200	250D	195	300	305	113	563
1800	50	200	250	300D	225	360	365	138	675

DIMENSIONS (INCHES)									
A	B	C	D	E	F	G	H	J	K
36	1	4	5	6D	4 1/2	7	7 1/2	2 3/4	13 1/2
48	1 1/2	6	7	8D	6	9	10	3 1/2	18
60	2	6	8	10D	7 3/4	12	12 1/4	4 1/2	22 1/2
72	2	8	10	12D	9	14	15	5 1/2	27

COLORS

LEGEND & ARROW - WHITE (REFL)
BACKGROUND - BLUE (REFL)

D6-2

12/05

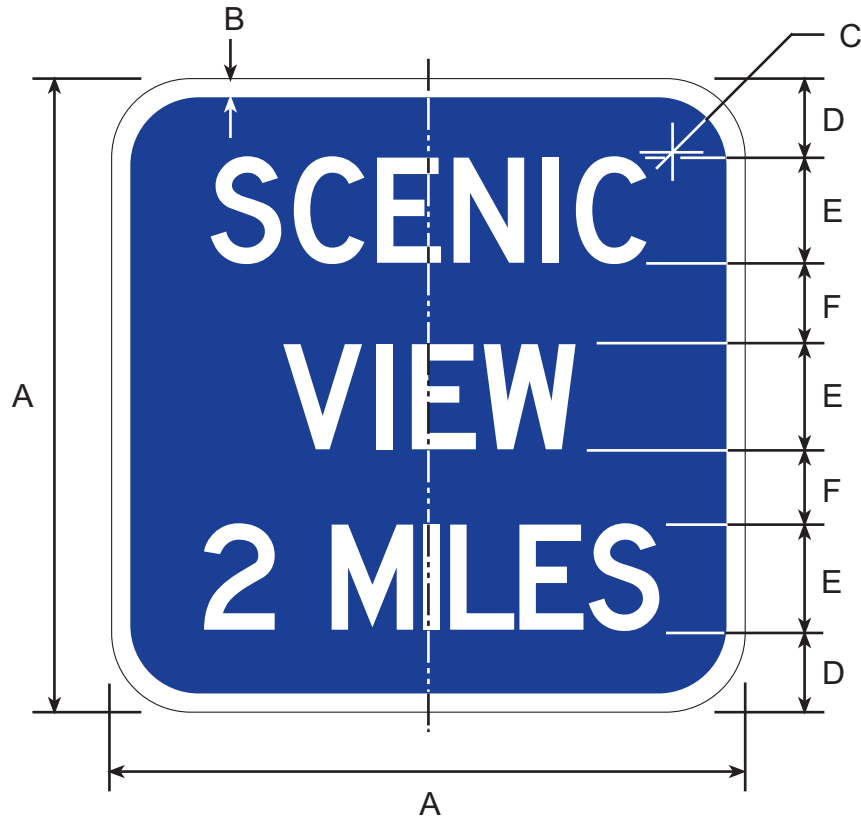

DIMENSIONS (MILLIMETERS)					
A	B	C	D	E	F
900	25	100	125	150D	100
1200	38	150	150	200D	150
1500	50	150	185	250D	190
1800	50	200	250	300D	200

DIMENSIONS (INCHES)					
A	B	C	D	E	F
36	1	4	5	6D	4
48	1 1/2	6	6	8D	6
60	2	6	7 1/2	10D	7 1/2
72	2	8	10	12D	8

COLORS

LEGEND - WHITE (REFL)
 BACKGROUND - BLUE (REFL)

D6-3

12/05

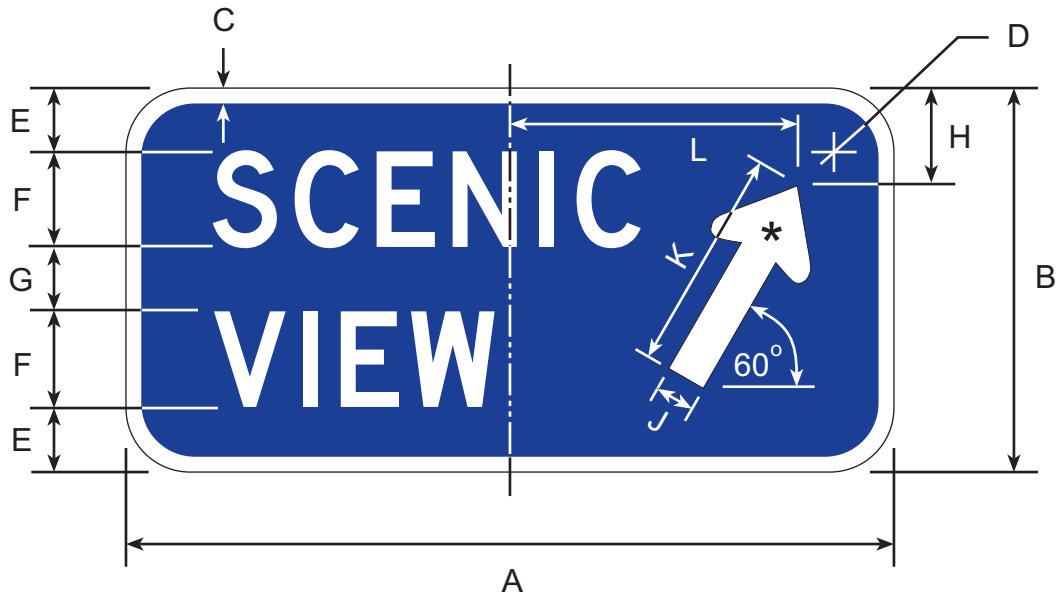

* SEE APPENDIX FOR ARROW DETAILS

DIMENSIONS (MILLIMETERS)										
A	B	C	D	E	F	G	H	J	K	L
1200	600	25	100	100	150D	100	150	69	350	500
1500	900	38	150	175	200D	150	200	88	500	600
1800	1200	50	150	250	250D	200	250	113	675	700
2400	1350	50	200	250	300D	250	300	138	775	950

DIMENSIONS (INCHES)										
A	B	C	D	E	F	G	H	J	K	L
48	24	1	4	4	6D	4	6	2 3/4	14	18
60	36	1 1/2	6	7	8D	6	8	3 1/2	20	24
72	48	2	6	10	10D	8	10	4 1/2	27	28
96	54	2	8	10	12D	10	12	5 1/2	31	38

COLORS

LEGEND & ARROW - WHITE (REFL)
BACKGROUND - BLUE (REFL)

RECREATIONAL FACILITY SYMBOL SIGNS

6/06

D5 SERIES

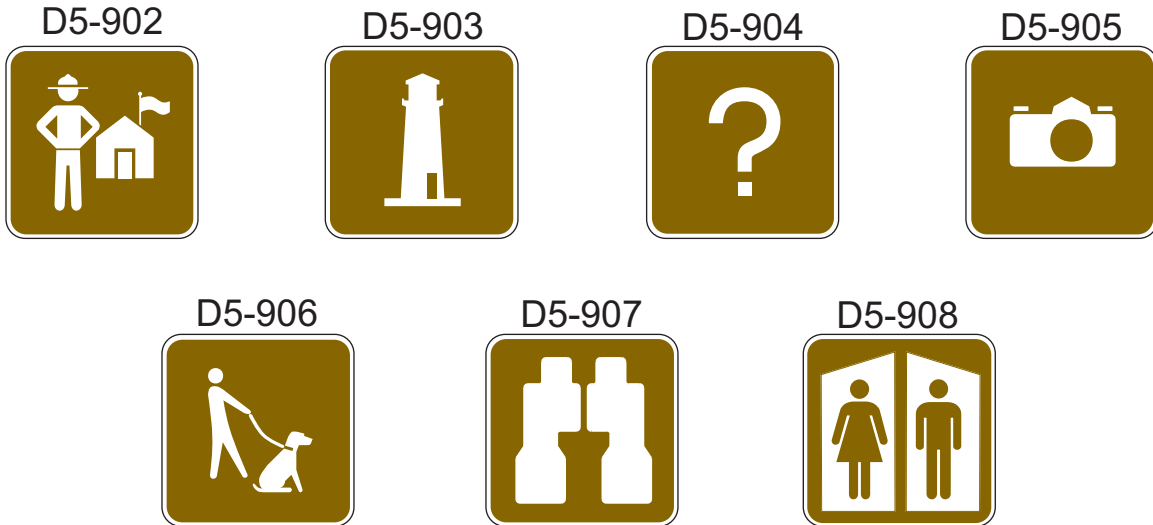

D7 SERIES



Note: All signs are 600 millimeters x 600 millimeters (24 inches x 24 inches), with a 13 millimeter (1/2 inch) border and a 38 millimeter (1 1/2 inch) corner radius

COLORS

SYMBOL — WHITE (REFL)
BACKGROUND — BROWN (REFL)

RECREATIONAL FACILITY SYMBOL SIGNS

6/06

D7 SERIES (CONT'D)



RECREATIONAL FACILITY LEGEND SIGNS



Note: All signs are 600 millimeters x 600 millimeters (24 inches x 24 inches), with a 13 millimeter (1/2 inch) border and a 38 millimeter (1 1/2 inch) corner radius

COLORS

SYMBOL & LEGEND — WHITE (REFL)
BACKGROUND — BROWN

D7-7701

10/97

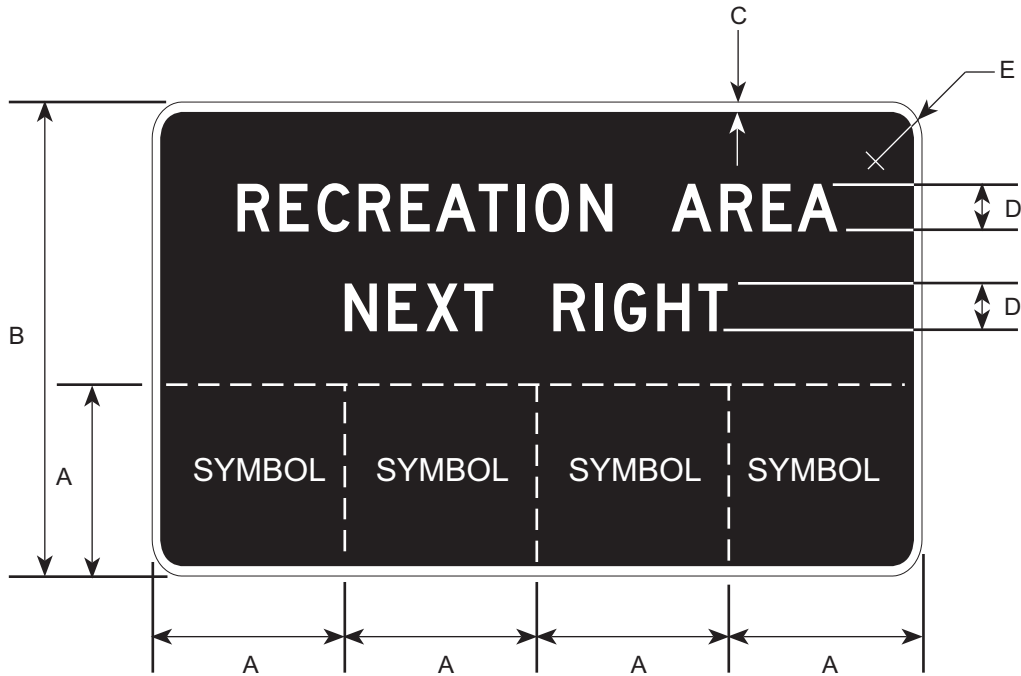

DIMENSIONS (MILLIMETERS)				
A	B	C	D	E
600	1500	16	150D	188

DIMENSIONS (INCHES)				
A	B	C	D	E
24	60	5/8	6D	7 1/2

COLORS

LEGEND - WHITE (REFL)
 BACKGROUND - BROWN (REFL)

D8-301

12/05

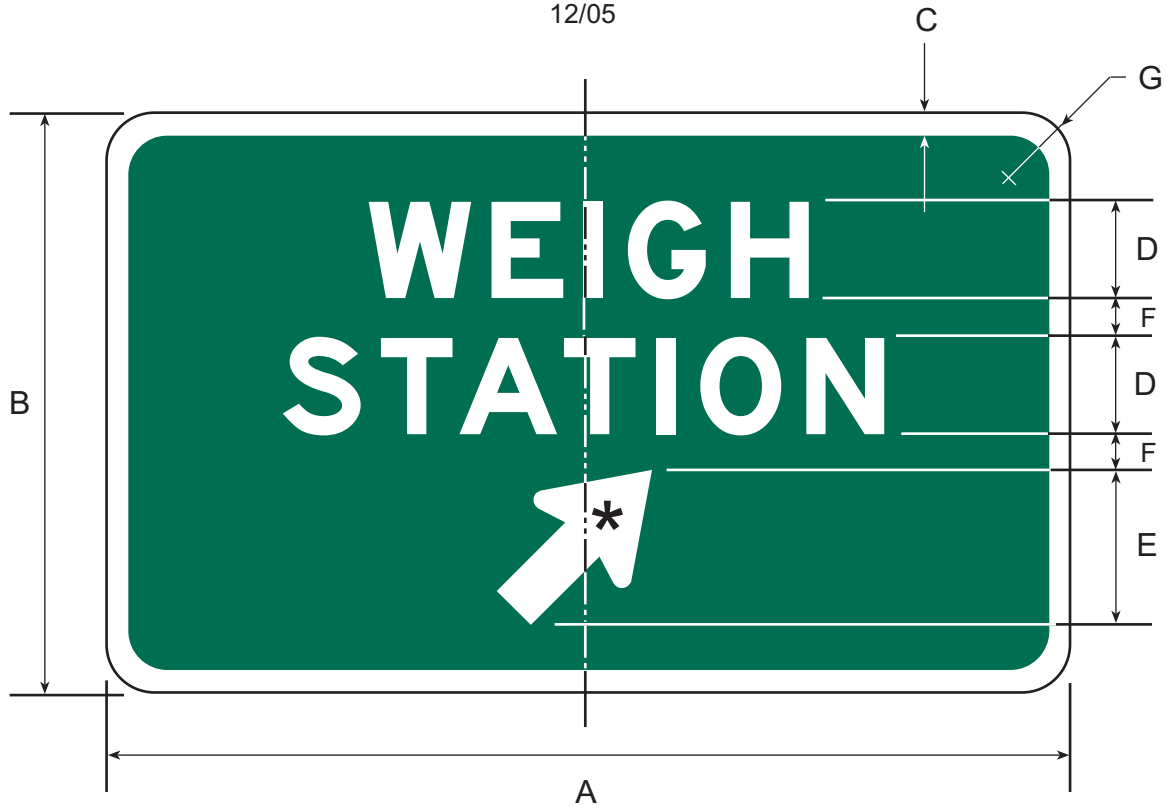

* SEE APPENDIX FOR STANDARD ARROW DETAILS

DIMENSIONS (MILLIMETERS)						
A	B	C	D	E	F	G
1200	1050	38	150E	NO.1	100	100
1500	1350	38	200E	NO.2	150	125
2100	1800	50	250E	NO.2	200	150

DIMENSIONS (INCHES)						
A	B	C	D	E	F	G
48	42	1 1/2	6E	NO.1	4	4
60	54	1 1/2	8E	NO.2	6	5
84	72	2	10E	NO.2	8	6

COLORS

LEGEND — WHITE (REFL)
 BACKGROUND — GREEN (REFL)

D9-1

10/97

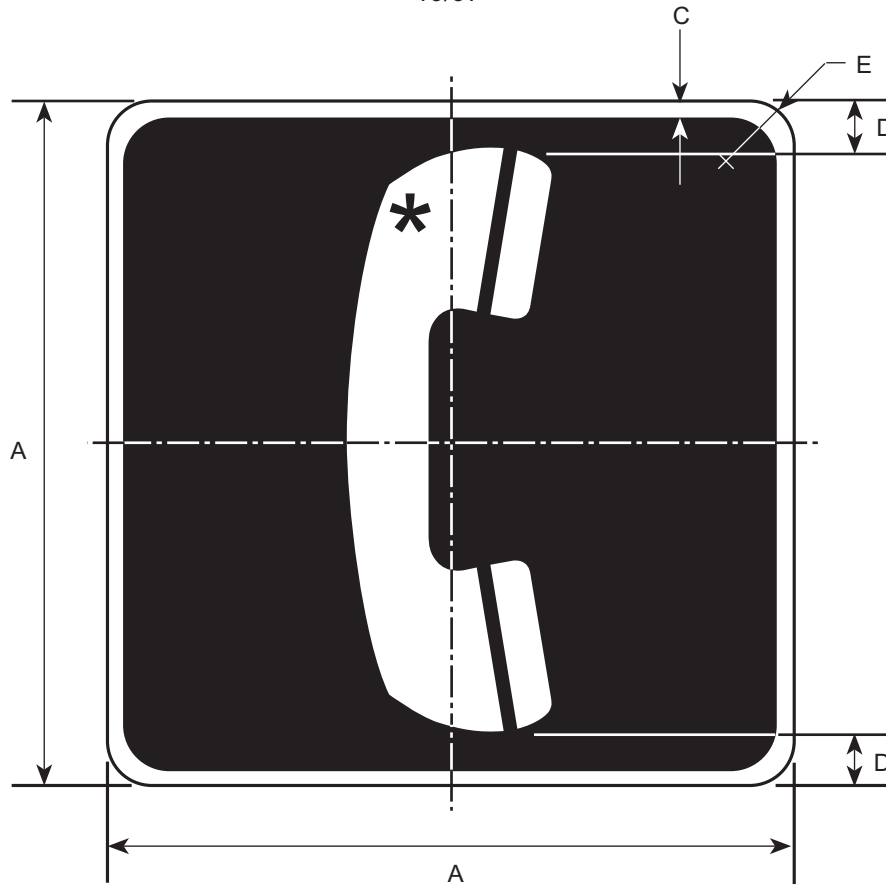

* SEE APPENDIX FOR SYMBOL DESIGN

DIMENSIONS (MILLIMETERS)			
A	C	D	E
450	13	25	38
600	13	38	38
750	19	50	47

DIMENSIONS (INCHES)			
A	C	D	E
18	1/2	1	1 1/2
24	1/2	1 1/2	1 1/2
30	3/4	2	1 7/8

COLORS

LEGEND — WHITE (REFL)
BACKGROUND — BLUE

D9-11A

1/06

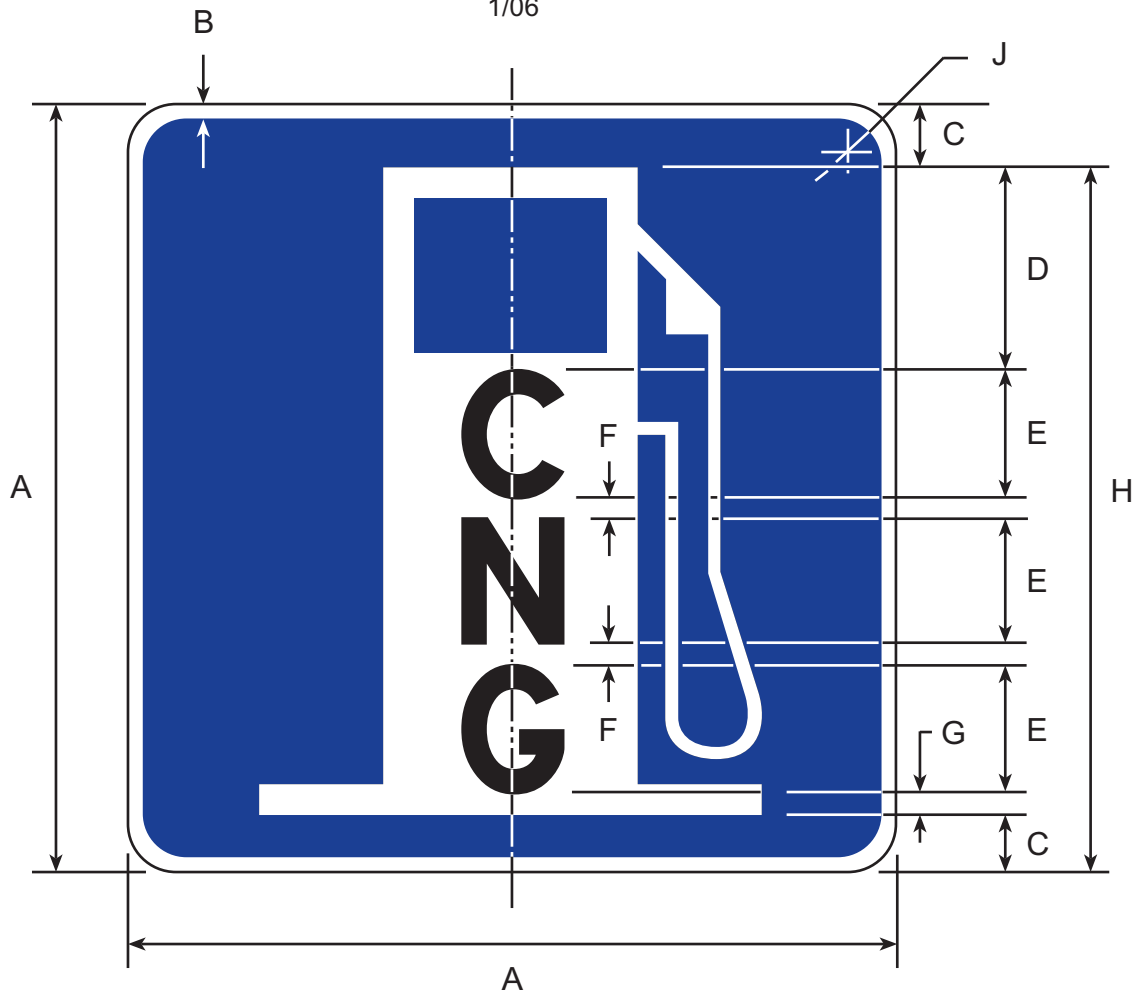

DIMENSIONS (MILLIMETERS)								
A	B	C	D	E	F	G	H	J
450	13	37.5	113	75EM	13	13	375	38
600	13	50	150	100EM	16	18	500	38
750	19	62.5	191	125EM	17	25	625	47

DIMENSIONS (INCHES)								
A	B	C	D	E	F	G	H	J
18	1/2	1 1/2	4 1/2	3EM	1/2	1/2	15	1 1/2
24	1/2	2	6	4EM	5/8	3/4	20	1 1/2
30	3/4	2 1/2	7 5/8	5EM	11/16	1	25	1 7/8

COLORS

LEGEND & BACKGROUND - BLUE (REFL)
 SYMBOL - WHITE (REFL)

D9-11B

1/06

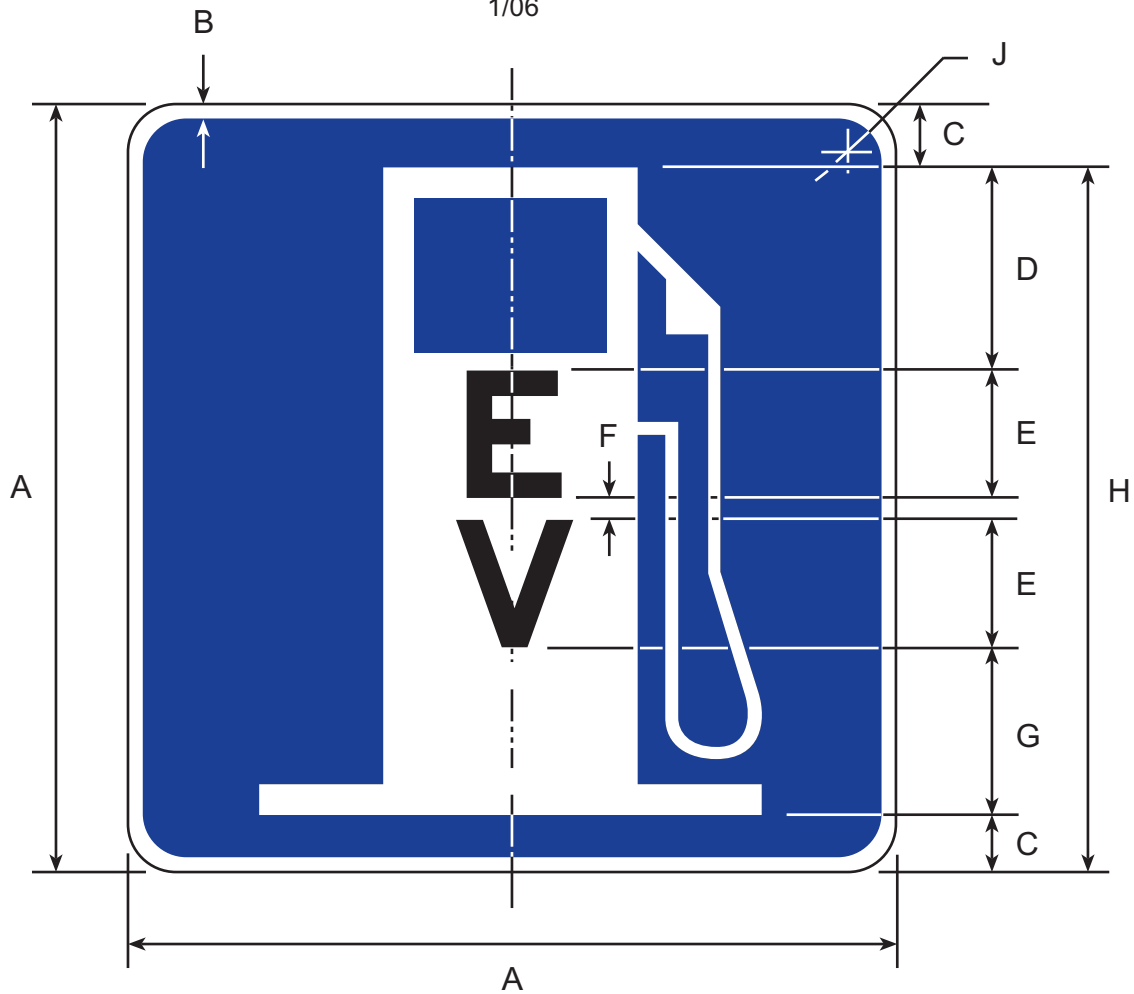

DIMENSIONS (MILLIMETERS)								
A	B	C	D	E	F	G	H	J
450	13	37.5	113	75EM	13	99	375	38
600	13	50	150	100EM	16	137	500	38
750	19	62.5	191	125EM	17	167	625	47

DIMENSIONS (INCHES)								
A	B	C	D	E	F	G	H	J
18	1/2	1 1/2	4 1/2	3EM	1/2	4	15	1 1/2
24	1/2	2	6	4EM	5/8	5 3/8	20	1 1/2
30	3/4	2 1/2	7 1/2	5EM	3/4	6 3/4	25	1 7/8

COLORS

LEGEND & BACKGROUND - BLUE (REFL)
 SYMBOL - WHITE (REFL)

D9-13

11/97



SIGN DIMENSIONS ARE 600 X 600mm. (24 X 24in)

COLORS

SYMBOL - WHITE (REFL)
BACKGROUND - BLUE (REFL)

D9-13A

12/05

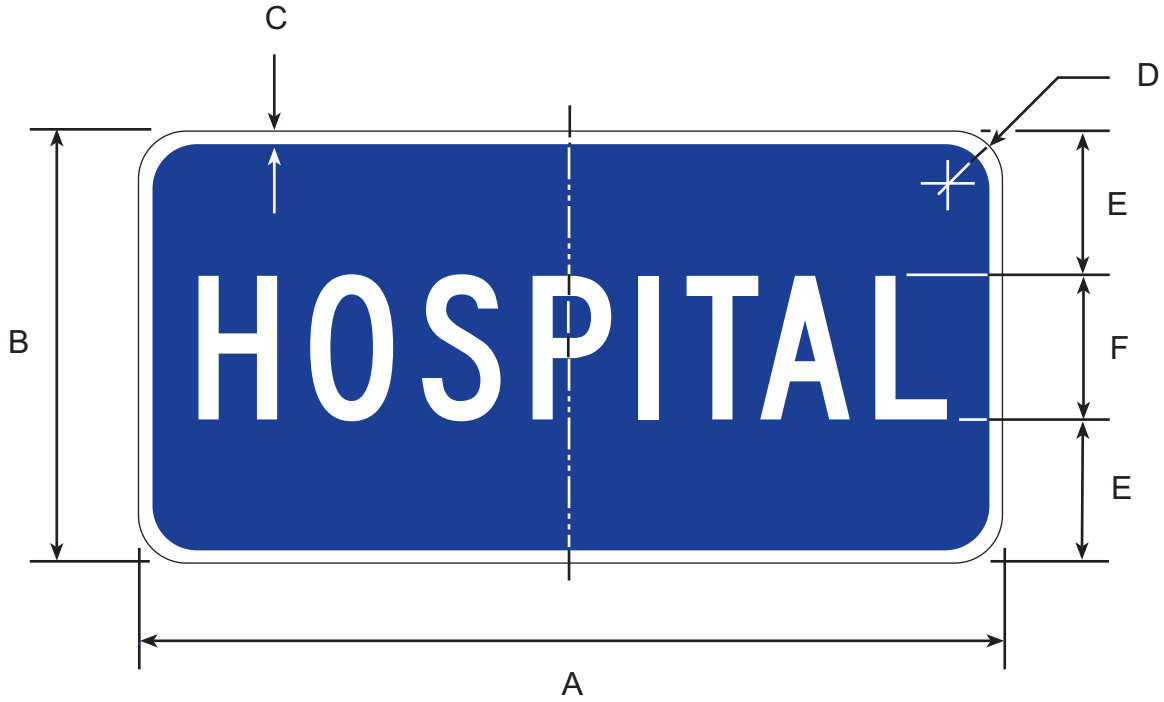

DIMENSIONS (MILLIMETERS)					
A	B	C	D	E	F
600	300	13	38	100	100C

DIMENSIONS (INCHES)					
A	B	C	D	E	F
24	12	1/2	1 1/2	4	4C

COLORS

LEGEND - WHITE (REFL)
BACKGROUND - BLUE (REFL)

D9-13B

12/05

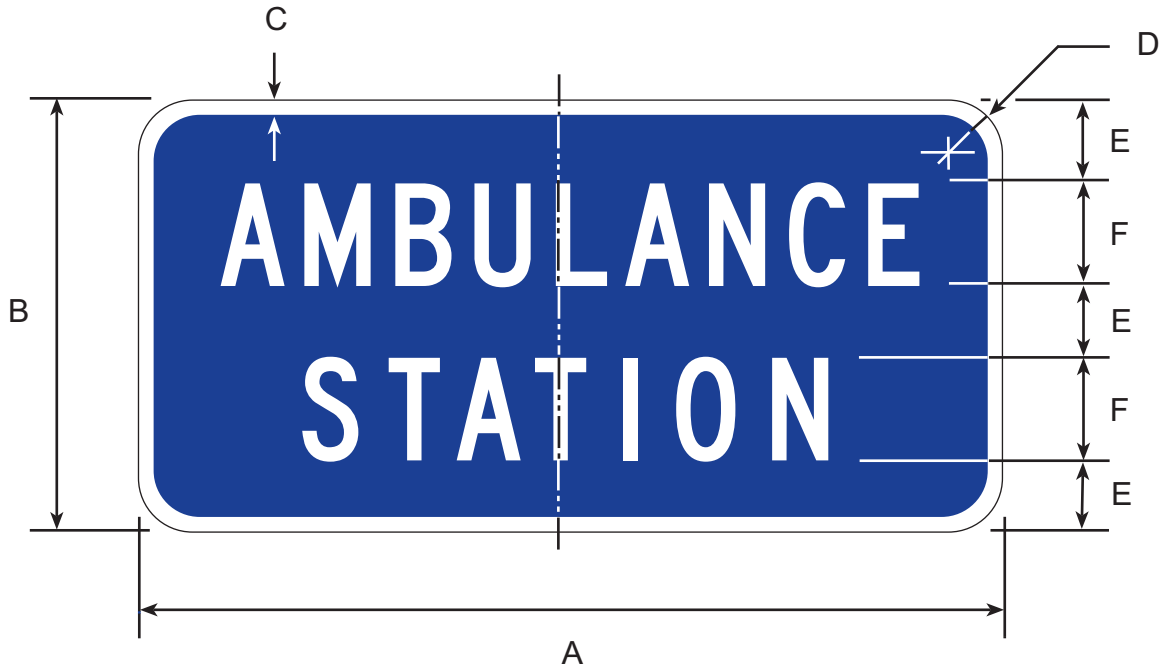

DIMENSIONS (MILLIMETERS)					
A	B	C	D	E	F
600	300	13	38	50	75C

DIMENSIONS (INCHES)					
A	B	C	D	E	F
24	12	1/2	1 1/2	2	3C

COLORS

LEGEND - WHITE (REFL)
 BACKGROUND - BLUE (REFL)

D9-13C

12/05

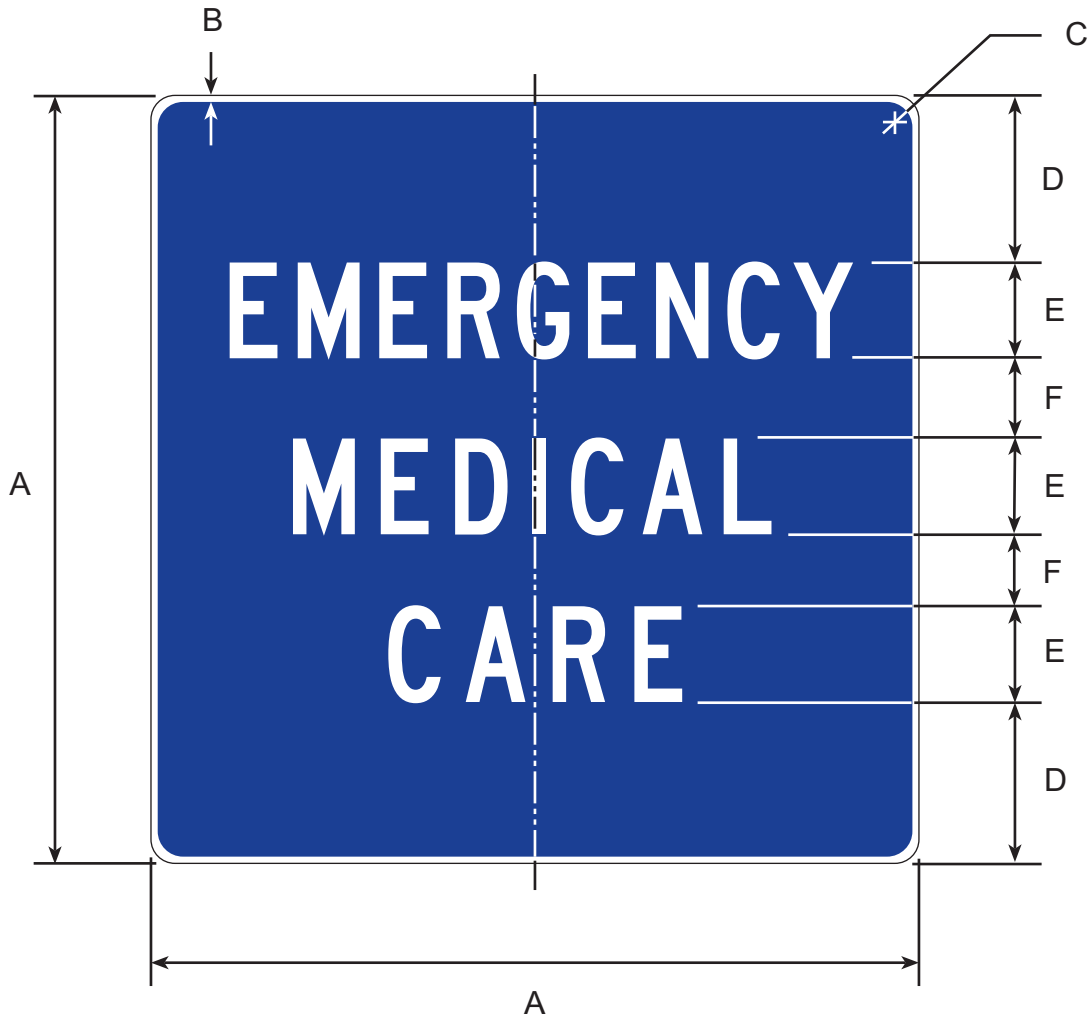

DIMENSIONS (MILLIMETERS)					
A	B	C	D	E	F
600	13	38	115	75C	72.5

DIMENSIONS (INCHES)					
A	B	C	D	E	F
24	1/2	1 1/2	4 3/4	3C	2 3/4

COLORS

LEGEND - WHITE (REFL)
BACKGROUND - BLUE (REFL)

D9-1301

11/97

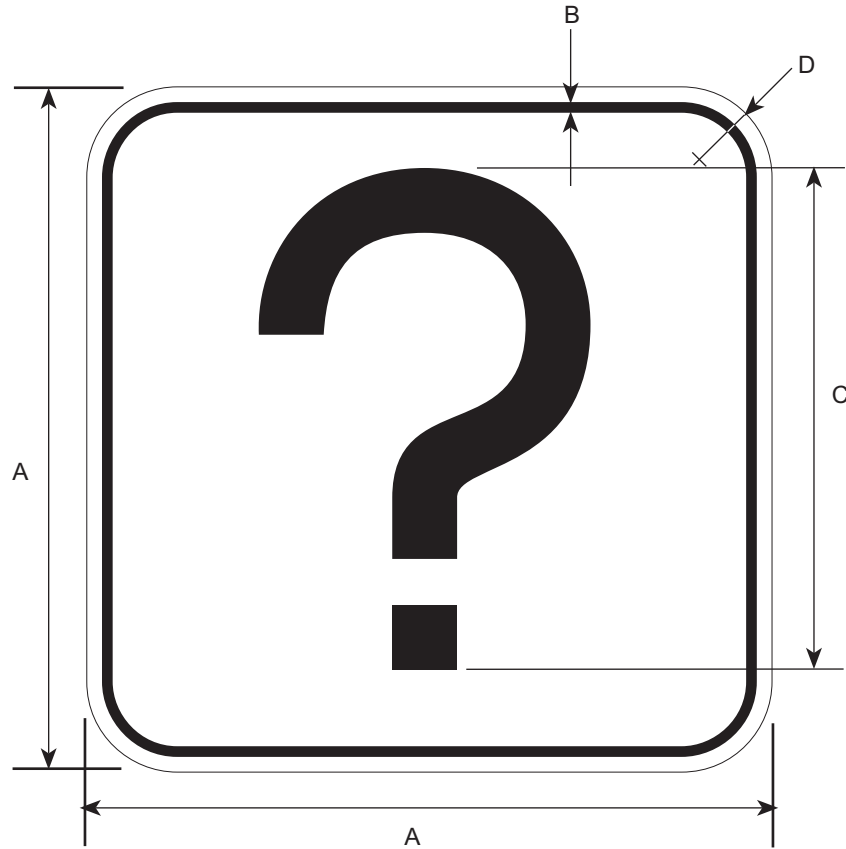

DIMENSIONS (MILLIMETERS)			
A	B	C	D
600	13	450	38

DIMENSIONS (INCHES)			
A	B	C	D
24	1/2	18	1 1/2

COLORS

LEGEND - WHITE (REFL.)
BACKGROUND - BLUE (REFL.)

D9-14

12/05



DIMENSIONS (MILLIMETERS)					
A	B	C	D	E	F
600	300	13	38	75	150C
750	450	13	38	125	200C

DIMENSIONS (INCHES)					
A	B	C	D	E	F
24	12	1/2	1 1/2	3	6C
30	18	1/2	1 1/2	5	8C

COLORS

LEGEND - WHITE (REFL)
BACKGROUND - BLUE (REFL)

D9-15

11/97

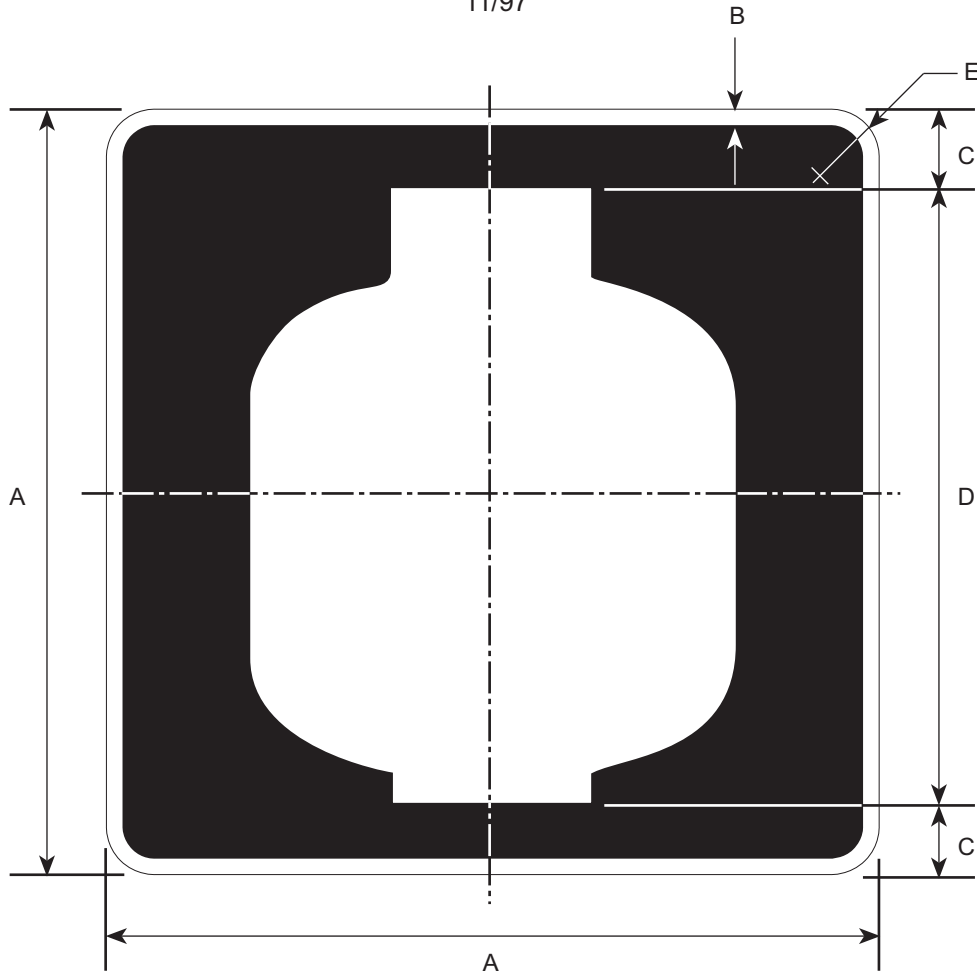

DIMENSIONS (MILLIMETERS)				
A	B	C	D	E
450	13	38	375	38
600	13	50	500	38
750	19	63	625	47

DIMENSIONS (INCHES)				
A	B	C	D	E
18	1/2	1 1/2	15	1 1/2
24	1/2	2	20	1 1/2
30	3/4	2 1/2	25	1 7/8

COLORS

SYMBOL - WHITE (REFL)
 BACKGROUND - BLUE (REFL)

D9-1601

1/06

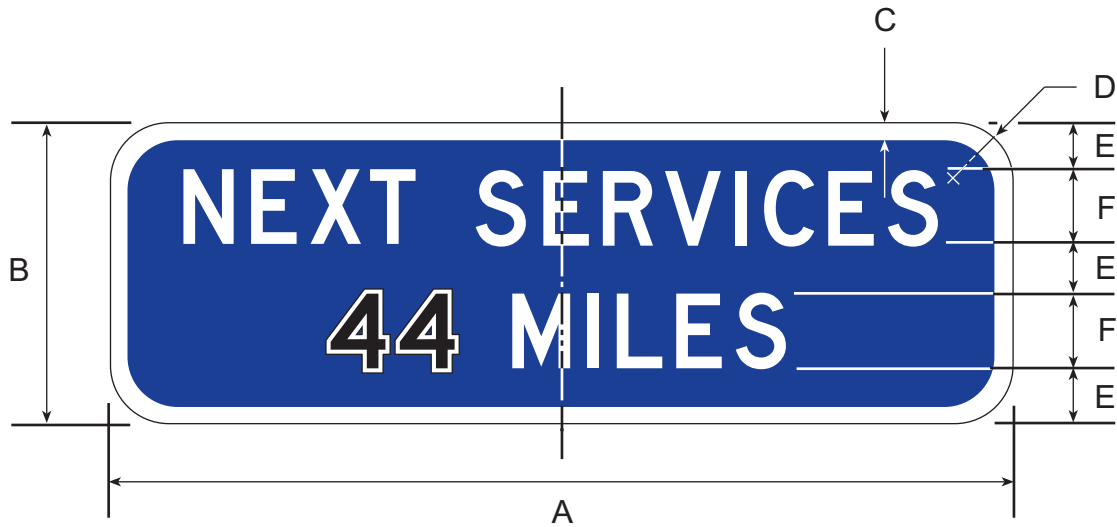

DIMENSIONS (MILLIMETERS)					
A	B	C	D	E	F
1800	600	38	100	100	150D
2400	900	38	150	165	200D

DIMENSIONS (INCHES)					
A	B	C	D	E	F
72	24	1 1/2	4	4	6D
96	36	1 1/2	6	6 1/2	8D

COLORS

LEGEND - WHITE (REFL.)
 BACKGROUND - BLUE (REFL.)

D10-1, D10-2 & D10-3

10/97

SINGLE FACED SIGNS

D10-3



SIGN	DIMENSIONS (MILLIMETERS)					
	SIGN SIZE	LETTER SIZE AND SERIES	NUM. SIZE AND SERIES	BORDER WIDTH	CORNER RADIUS	HOLE CTRS.
D10-1	250 X 450	100B	150D	13	25	375
	300 X 600	100C	250D	19	38	525
D10-2	250 X 675	100B	150D	13	25	600
	300 X 900	100C	250D	19	38	825
D10-3	250 X 900	100B	150D	13	25	825
	300 X 1200	100C	250D	19	38	110

SIGN	DIMENSIONS (INCHES)					
	SIGN SIZE	LETTER SIZE AND SERIES	NUM. SIZE AND SERIES	BORDER WIDTH	CORNER RADIUS	HOLE CTRS.
D10-1	10 X 18	4B	6D	1/2	1	15
	12 X 24	4C	10D	3/4	1 1/2	21
D10-2	10 X 27	4B	6D	1/2	1	24
	12 X 36	4C	10D	3/4	1 1/2	33
D10-3	10 X 36	4B	6D	1/2	1	33
	12 X 48	4C	10D	3/4	1 1/2	44

COLORS

LEGEND - WHITE (REFL.)
BACKGROUND - GREEN (REFL.)

D10-101, 201, 301

4/06

DOUBLE FACED SIGNS

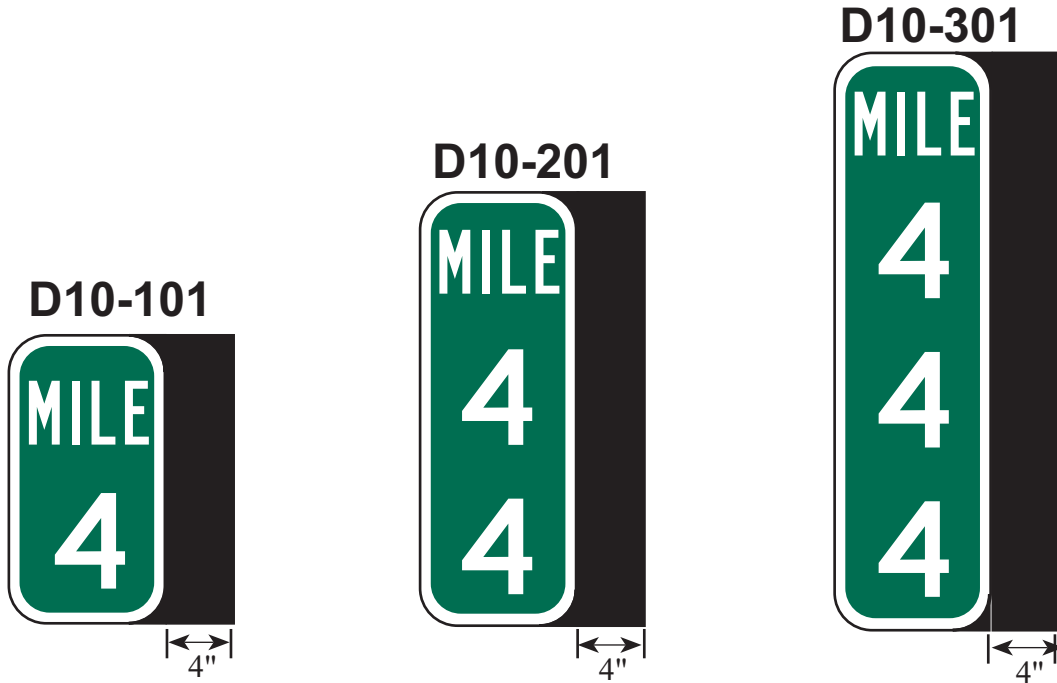

SIGN	DIMENSIONS (MILLIMETERS)					
	SIGN SIZE	LETTER SIZE AND SERIES	NUM. SIZE AND SERIES	BORDER WIDTH	CORNER RADIUS	HOLE CTRS.
D10-101	350 X 450	100B	150D	13	25	375
D10-201	350 X 675	100B	150D	13	25	600
D10-301	350 X 900	100B	150D	13	25	825

SIGN	DIMENSIONS (INCHES)					
	SIGN SIZE	LETTER SIZE AND SERIES	NUM. SIZE AND SERIES	BORDER WIDTH	CORNER RADIUS	HOLE CTRS.
D10-101	14 X 18	4B	6D	1/2	1	15
D10-201	14 X 27	4B	6D	1/2	1	24
D10-301	14 X 36	4B	6D	1/2	1	33

COLORS

LEGEND - WHITE (REFL.)
BACKGROUND - GREEN (REFL.)

D13-1

1/06



1 1/16" x 36" 1/2" x 0.45" PIANO
HINGE COVERED TO MATCH SIGN

DIMENSIONS (MILLIMETERS)						
A	B	C	D	E	F	G
900	750	9	125	200C	100	38

DIMENSIONS (INCHES)						
A	B	C	D	E	F	G
36	30	3/8	5	8C	4	1 1/2

COLORS

LEGEND - WHITE (REFL.)
BACKGROUND - BLUE (REFL.)

D13-2

1/06

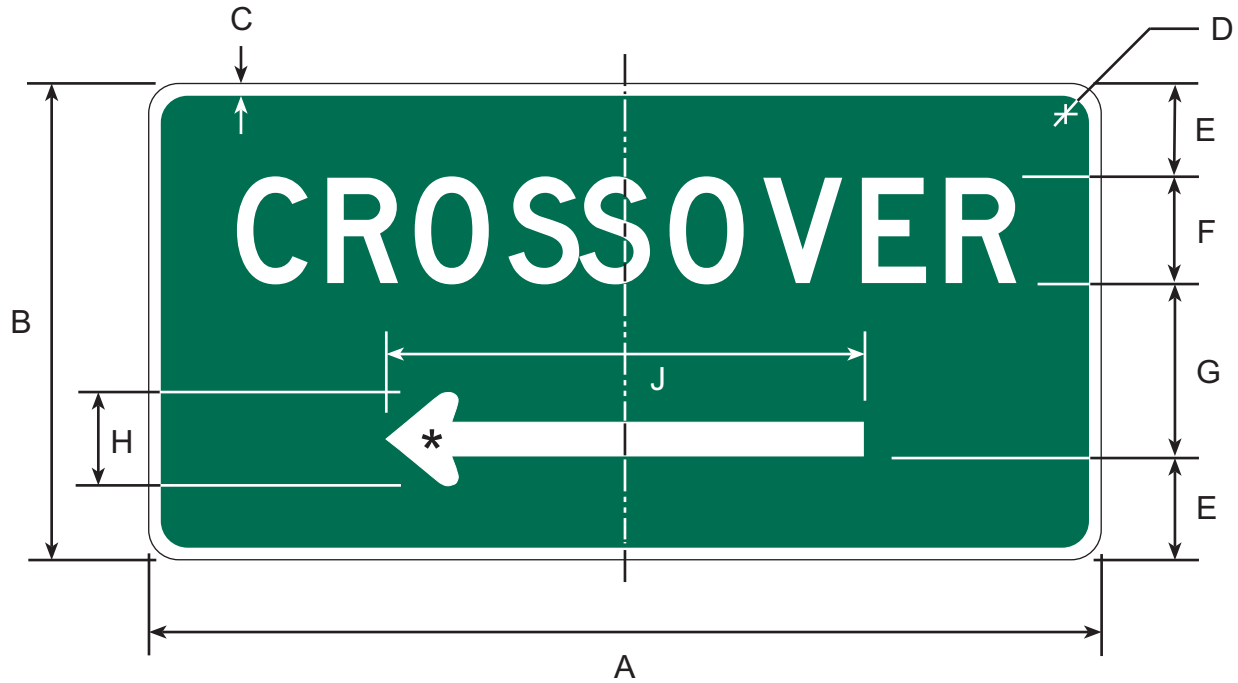

* SEE APPENDIX FOR ARROW DETAILS

DIMENSIONS (MILLIMETERS)								
A	B	C	D	E	F	G	H	J
1500	750	19	47	150	150D	300	150	750
1800	900	25	50	175	200D	350	200	900

DIMENSIONS (INCHES)								
A	B	C	D	E	F	G	H	J
60	30	3/4	1 7/8	6	6D	12	6	30
72	36	1	2	7	8D	14	8	36

COLORS

LEGEND - WHITE (REFL)
BACKGROUND - GREEN (REFL)

D13-3

12/05

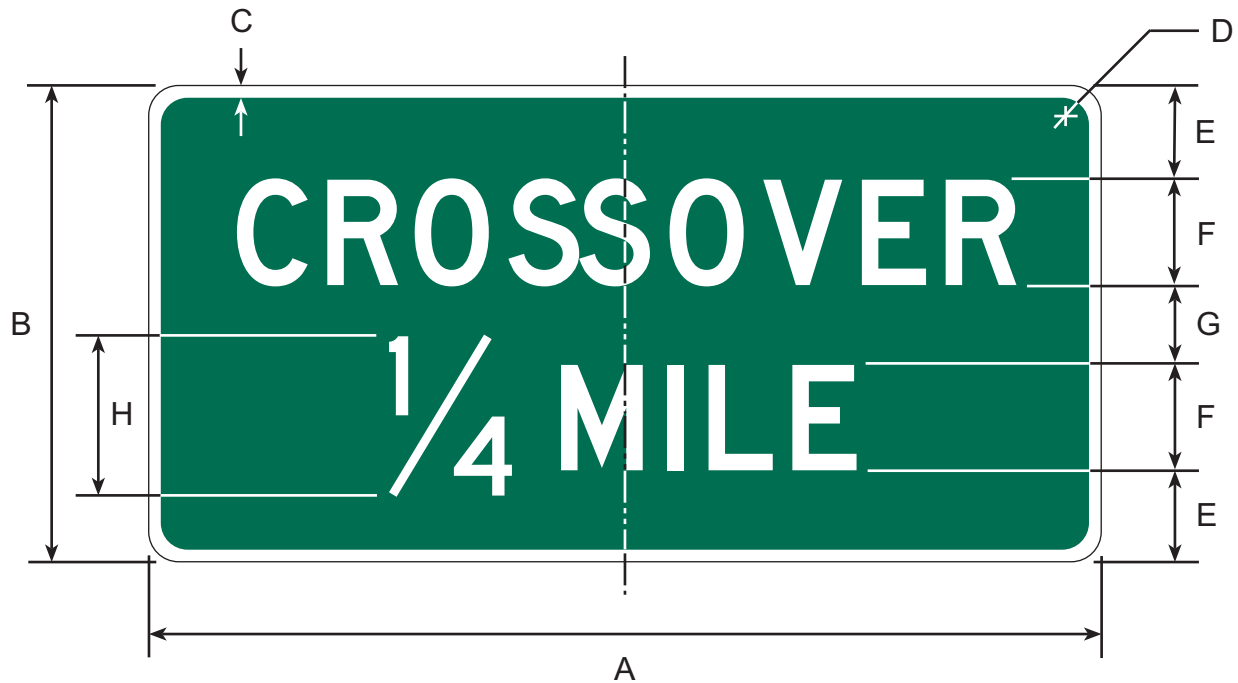

DIMENSIONS (MILLIMETERS)							
A	B	C	D	E	F	G	H
1500	750	19	47	150	150D	150	225
1800	900	25	50	175	200D	150	300

DIMENSIONS (INCHES)							
A	B	C	D	E	F	G	H
60	30	3/4	1 7/8	6	6D	6	9
72	36	1	2	7	8D	6	12

COLORS

LEGEND - WHITE (REFL)
BACKGROUND - GREEN (REFL)

E1-1

1/06

ADVANCE GUIDE SIGNS



SIZE CODE	DIMENSIONS (MILLIMETERS)									
	EXIT PANEL			ROUTE MARKER	CARDINAL DIRECTION	PLACE NAME	ACTION MESSAGE			BORDER WIDTH
	WORD	NUM.	LETTER				NUM.	FRACT.	WORD	
B	200E	300E	300E	600	250E/200E	265/200	250E	200E	200E	38
C	250E	375E	375E	900	300E/250E	332/250	300E	250E	250E	50
D	300E	450E	450E	900	375E/300E	400/300	375E	300E	300E	50
E	300E	450E	450E	900	375E/300E	400/300	375E	300E	300E	50

SIZE CODE	DIMENSIONS (INCHES)									
	EXIT PANEL			ROUTE MARKER	CARDINAL DIRECTION	PLACE NAME	ACTION MESSAGE			BORDER WIDTH
	WORD	NUM.	LETTER				NUM.	FRACT.	WORD	
B	8E	12E	12E	24	10E/8E	10.6/8	10E	8E	8E	1 1/2
C	10E	15E	15E	36	12E/10E	13.3/10	12E	10E	10E	2
D	10E	15E	15E	36	15E/12E	16/12	15E	12E	12E	2
E	12E	18E	18E	36	15E/12E	16/12	15E	12E	12E	2

COLORS

LEGEND — WHITE (REFL)
BACKGROUND — GREEN (REFL)

E1-4

8/03

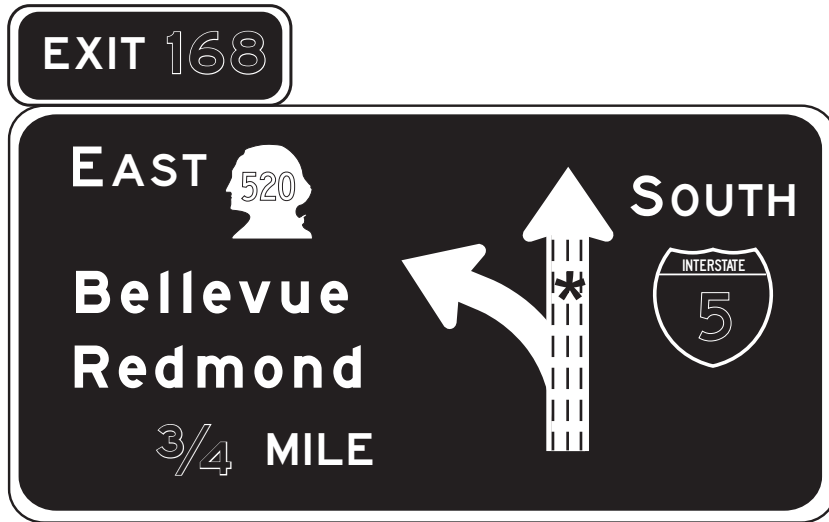

NOTE: SEE APPENDIX FOR TYPICAL ARROW DETAILS. SEE PLANS FOR SPECIFIC ARROW DETAILS.

* LANE STRIPE BLACK

SIZE CODE	DIMENSIONS (MILLIMETERS)				
	ROUTE MARKER	CARD. DIR.	PLACE NAME	ARROW DIMEN.	BORDER WIDTH
B	600	250E/200E	265/200	SEE PLANS	37.5
C	900	300E/250E	332/250		50
D	900	375E/300E	400/300		50

SIZE CODE	DIMENSIONS (INCHES)				
	ROUTE MARKER	CARDINAL DIRECTION	PLACE NAME	ARROW DIMEN.	BORDER WIDTH
B	24	10E/8E	10.6/8	SEE PLANS	1 1/2
C	36	12E/10E	13.3/10		2
D	36	15E/12E	16/12		2

GRAPHIC COMPONENT

Lane Width
 Lane Lines
 Space between Lane Lines
 Arrowheads
 Stem Height (to upper point of departure-minimum)
 Space between arrowheads and route shield and
 between route shield and cardinal direction

SIZE

5' (125 mm)
 1" x 6" (25 x 150 mm)
 6" (150 mm)
 Standard "up" Arrow
 30" (750 mm)
 12" (300 mm)

COLORS

LEGEND - WHITE (REFL)
 BACKGROUND - GREEN (REFL)

E2-1A

11/97



NOTE: WHITE ON BROWN MAY BE SPECIFIED ON THE PLANS FOR RECREATION SIGNING. SIZE CODE "E" SHOULD BE USED FOR OVERHEAD INSTALLATION.

SIZE CODE	DIMENSIONS (MILLIMETERS)					
	A	B	C	D	E	F
A	2100	900	38	200E	138	100
B	2700	1200	50	250E	200	150

SIZE CODE	DIMENSIONS (INCHES)					
	A	B	C	D	E	F
A	84	36	1 1/2	8E	5 1/2	4
B	108	48	2	10E	8	6

COLORS

LEGEND — WHITE (REFL)
BACKGROUND — GREEN (REFL)

E3-101

1/06



OPTIONAL

SIZE CODE	DIMENSIONS (MILLIMETERS)		
	PLACE NAME	ACTION MESS.	BORDER WIDTH
B	265/200	200E	38
C	325/250	250	50

SIZE CODE	DIMENSIONS (INCHES)		
	PLACE NAME	ACTION MESS.	BORDER WIDTH
B	10.6/8	8E	1 1/2
C	13/10	10E	2

COLORS

LEGEND — WHITE (REFL)
BACKGROUND — GREEN (REFL)

E4-301

4/03



SIZE CODE	DIMENSIONS (MILLIMETERS)							
	EXIT			ROUTE MARKER	CARDINAL DIRECTION	PLACE NAME	ACTION MESS.	BORDER WIDTH
	WORD	NUM.	LETTER					
B	200E	300E	300E	600	250E/200E	265/200	200E	38
C	250E	375E	375E	900	300E/250E	332/250	250E	50
D	250E	375E	375E	900	375E/300E	400/300	300E	50
E	300E	450E	450E	900	375E/300E	400/300	300E	50

SIZE CODE	DIMENSIONS (INCHES)							
	EXIT			ROUTE MARKER	CARDINAL DIRECTION	PLACE NAME	ACTION MESS.	BORDER WIDTH
	WORD	NUM.	LETTER					
B	8E	12E	12E	24	10E/8E	10.6/8	8E	1 1/2
C	10E	15E	15E	36	12E/10E	13.3/10	10E	2
D	10E	15E	15E	36	15E/12E	16/12	12E	2
E	12E	18E	18E	36	15E/12E	16/12	12E	2

COLORS

LEGEND — WHITE (REFL)
BACKGROUND — GREEN (REFL)

E4-501

1/06



THE EXIT ONLY PORTION SHALL BE NON-REFLECTIVE BLACK MESSAGE ON A REFLECTIVE YELLOW BACKGROUND. THE BORDER SHALL BE BLACK FOR THE YELLOW REFLECTIVE BACKGROUND PORTION OF THE SIGN AND WHITE FOR THE GREEN REFLECTIVE BACKGROUND PORTION OF THE SIGN. THE WHITE AND BLACK BORDER SHALL MATCH EVENLY.

SEE E11-I FOR PANEL DETAILS WHEN REVISING EXISTING GUIDE SIGN INSTALLATIONS.

* WHEN USED

** SEE APPENDIX FOR STANDARD ARROW DETAILS

SIZE CODE	DIMENSIONS (MILLIMETERS)								
	* EXIT PANEL			ROUTE MARKER	CARDINAL DIRECTION	PLACE NAME	ARROW SIZE	"EXIT ONLY"	BORDER WIDTH
	WORD	NUM.	LETTER						
B	250E	375E	375E	600	250E/200E	265/200	NO.7	200E	38
C	300E	450E	450E	900	300E/250E	332/250	NO.8	250E	50
E	300E	450E	450E	900	375E/300E	400/300	NO.8	300E	50

SIZE CODE	DIMENSIONS (INCHES)								
	* EXIT PANEL			ROUTE MARKER	CARDINAL DIRECTION	PLACE NAME	ARROW SIZE	"EXIT ONLY"	BORDER WIDTH
	WORD	NUM.	LETTER						
B	10E	15E	15E	24	10E/8E	10.6/8	NO.7	8E	1 1/2
C	12E	18E	18E	36	12E/10E	13.3/10	NO.8	10E	2
E	12E	18E	18E	36	15E/12E	16/12	NO.8	12E	2

COLORS

LEGEND — WHITE (REFL)
BACKGROUND — GREEN (REFL)

E5-1

10/03

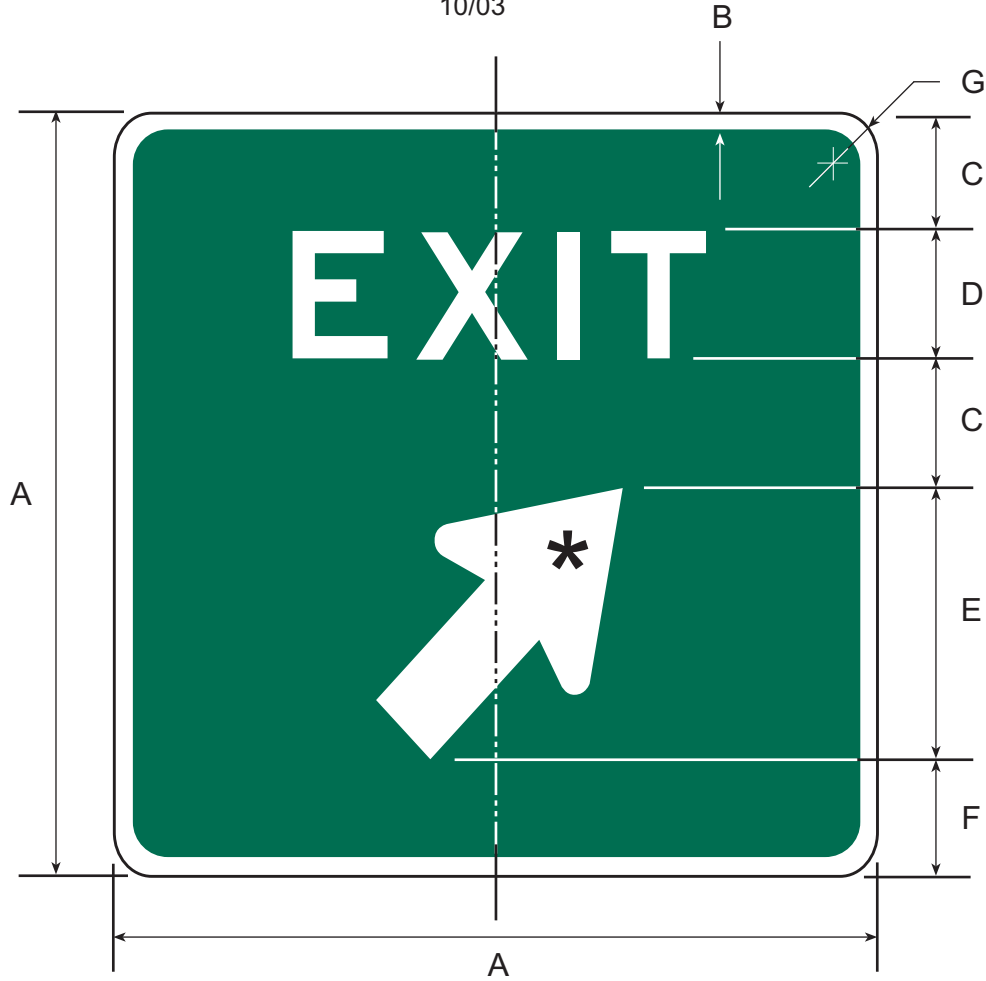

* SEE APPENDIX FOR STANDARD ARROW DETAILS

SIGN	DIMENSIONS (MILLIMETERS)							
	A	B	C	D	ARROW SIZE	E	F	G
A	1200	38	200	250E	NO.3	409	141	100
B	1500	50	250	300E	NO.4	591	109	150

SIGN	DIMENSIONS (INCHES)							
	A	B	C	D	ARROW SIZE	E	F	G
A	48	1 1/2	8	10E	NO.3	16 3/8	5 5/8	4
B	60	2	10	12E	NO.4	23 5/8	4 3/8	6

COLORS

LEGEND— WHITE (REFL)
BACKGROUND— GREEN (REFL)

E5-1A

1/06



* SEE APPENDIX FOR STANDARD ARROW DETAILS

SIGN	DIMENSIONS (MILLIMETERS)										
	A	B	C	D	E	F	G	ARROW SIZE	H	J	K
A	1200	38	200	250E	300E	250	369	NO.2	200	150	100
B	VAR	50	250	250E	375E	325	506	NO.5	250	188	150

SIGN	DIMENSIONS (INCHES)										
	A	B	C	D	E	F	G	ARROW SIZE	H	J	K
A	48	1 1/2	8	10E	12E	10	14 3/4	NO.2	8	6	4
B	VAR	2	10	12E	15E	13	20 1/4	NO.5	10	7 1/2	6

COLORS

LEGEND— WHITE (REFL)
BACKGROUND— GREEN (REFL)

E5-3

1/06

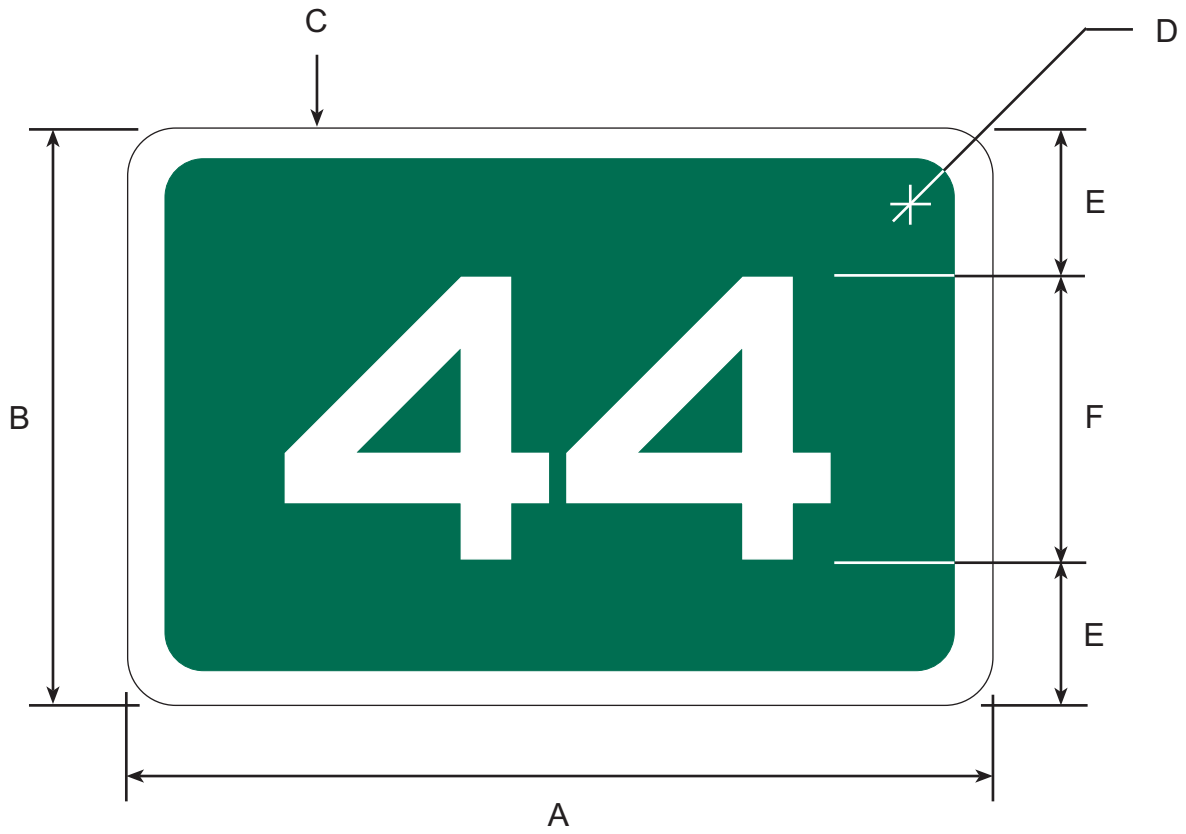

DIMENSIONS (MILLIMETERS)					
A	B	C	D	E	F
VAR	600	38	75	150	300E
VAR	600	38	75	113	375E

DIMENSIONS (INCHES)					
A	B	C	D	E	F
VAR	24	1 1/2	3	6	12E
VAR	24	1 1/2	3	4 1/2	15E

COLORS

LEGEND - WHITE (REFL)
 BACKGROUND - GREEN (REFL)

E5-4

1/06

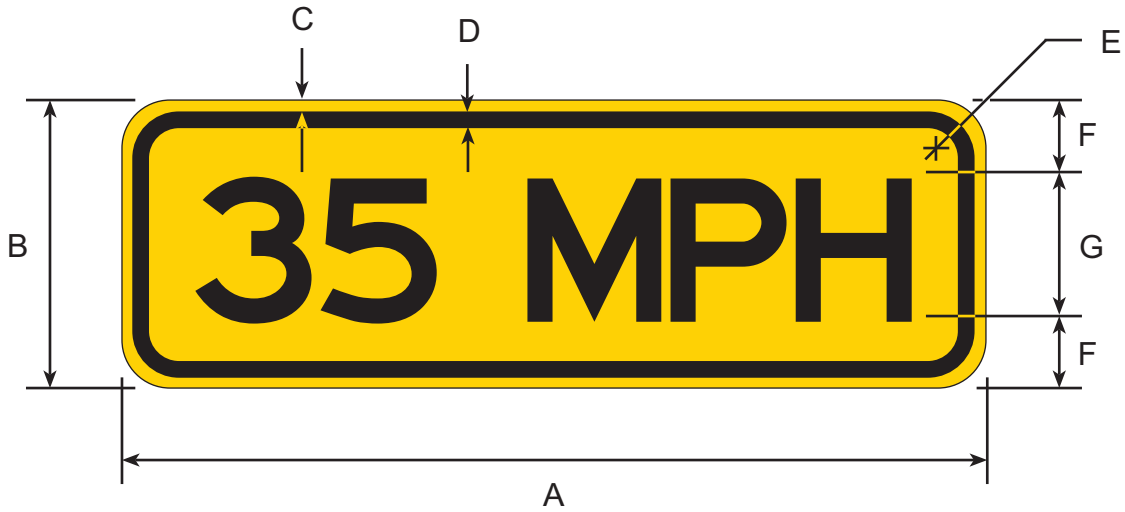

DIMENSIONS (MILLIMETERS)						
A	B	C	D	E	F	G
1800	600	25	31	75	150	300E

DIMENSIONS (INCHES)						
A	B	C	D	E	F	G
72	24	1	1 1/4	3	6	12E

COLORS

LEGEND - BLACK (NON-REFL)
 BACKGROUND - YELLOW (REFL)

E6-101

1/06



* SEE APPENDIX FOR STANDARD ARROW DETAILS

SIZE CODE	DIMENSIONS (MILLIMETERS)										
	EXIT PANEL			ROUTE MARKER	CARDINAL DIRECTION	PLACE NAME	ACTION MESSAGE			BORDER WIDTH	ARROW SIZE
	WORD	NUM	LETTER				NUM.	FRACT.	WORD		
B	200E	300E	300E	600	250E/200E	265/200	200E	250E	200E	37.5	3 OR 4
C	250E	375E	375E	900	300E/250E	332/250	300E	250E	250E	50	3 OR 4
D	250E	375E	375E	900	300E/250E	400/300	375E	300E	300E	50	5 OR 6
E	300E	450E	450E	900	375E/300E	400/300	375E	300E	300E	50	5 OR 6

SIZE CODE	DIMENSIONS (INCHES)										
	EXIT PANEL			ROUTE MARKER	CARDINAL DIRECTION	PLACE NAME	ACTION MESSAGE			BORDER WIDTH	ARROW SIZE
	WORD	NUM	LETTER				NUM.	FRACT.	WORD		
B	8E	12E	12E	24	10E/8E	10.6/8	10 E	8 E	8 E	1 1/2	3 OR 4
C	10E	15E	15E	36	12E/10E	13.3/10	12 E	10 E	10 E	2	3 OR 4
D	10E	15E	15E	36	15E/12E	16/12	15 E	12 E	12 E	2	5 OR 6
E	12E	18E	18E	36	15E/12E	16/12	15 E	12 E	12 E	2	5 OR 6

COLORS

LEGEND— WHITE (REFL)
BACKGROUND— GREEN (REFL)

E6-2

1/06



*** SEE APPENDIX FOR STANDARD ARROW DETAILS WITH OR WITHOUT DOWN ARROW

SIZE CODE	DIMENSIONS (MILLIMETERS)				
	ROUTE MARKER	CARDINAL DIRECTION	PLACE NAME	ARROW DIMEN.	BORDER WIDTH
B	600	250E/200E	265/200	NO. 7	38
C	900	300E/250E	332/250	NO. 8	50
D	900	375E/300E	400/300	NO. 8	50

SIZE CODE	DIMENSIONS (INCHES)				
	ROUTE MARKER	CARDINAL DIRECTION	PLACE NAME	ARROW DIMEN.	BORDER WIDTH
B	24	10E/8E	10.6/8	NO. 7	1 1/2
C	36	12E/10E	13.3/10	NO. 8	2
D	36	15E/12E	16/12	NO. 8	2

COLORS

LEGEND — WHITE (REFL)
BACKGROUND — GREEN (REFL)

E7-1

1/06



NOTE: USE 18" SHIELD WITH SIZE CODE A & B. USE 24" SHIELD WITH SIZE C. ADD 6" TO VERTICAL DIMENSION FOR EACH SHIELD USED.

SIZE CODE	DIMENSIONS (MILLIMETERS)								
	LETTER SIZE		VERT. DIMENSION			BORDER WIDTH	CORNER RADIUS		
	PLACE	NUM.	1 LINE	2 LINE	3 LINE		1 LINE	2 LINE	3 LINE
A	200/150	200	600	900	1200	38	75	150	150
B	265/200	265	750	1200	1650	38	75	150	225
C	332/250	332	900	1500	2100	50	150	225	300

SIZE CODE	DIMENSIONS (INCHES)								
	LETTER SIZE		VERT. DIMENSION			BORDER WIDTH	CORNER RADIUS		
	PLACE	NUM.	1 LINE	2 LINE	3 LINE		1 LINE	2 LINE	3 LINE
A	8/6	8	24	36	48	1 1/2	3	6	6
B	10.6/8	10.6	30	48	66	1 1/2	3	6	9
C	13.3/10	13.3	36	60	84	2	6	9	12

COLORS

LEGEND — WHITE (REFL)
BACKGROUND — GREEN (REFL)

E8-1

1/06



NOTE: SIZE CODE B IS INTENDED FOR USE ON EXPRESSWAYS

SIZE CODE	DIMENSIONS (MILLIMETERS)							
	LETTER SIZE			VERT. DIMENSION		BORDER WIDTH	CORNER RADIUS	
	PLACE	NUM.	FRACT	2 LINE	3 LINE		2 LINE	3 LINE
B	265/200	265	200	1200	1650	38	150	225
C	332/250	332	250	1500	2100	50	225	300

SIZE CODE	DIMENSIONS (INCHES)							
	LETTER SIZE			VERT. DIMENSION		BORDER WIDTH	CORNER RADIUS	
	PLACE	NUM.	FRACT	2 LINE	3 LINE		2 LINE	3 LINE
B	10.6/8	10.6	8	48	66	1 1/2	6	9
C	13.3/10	13.3	10	60	84	2	9	12

COLORS

LEGEND — WHITE (REFL)
BACKGROUND — GREEN (REFL)

E8-2

1/06

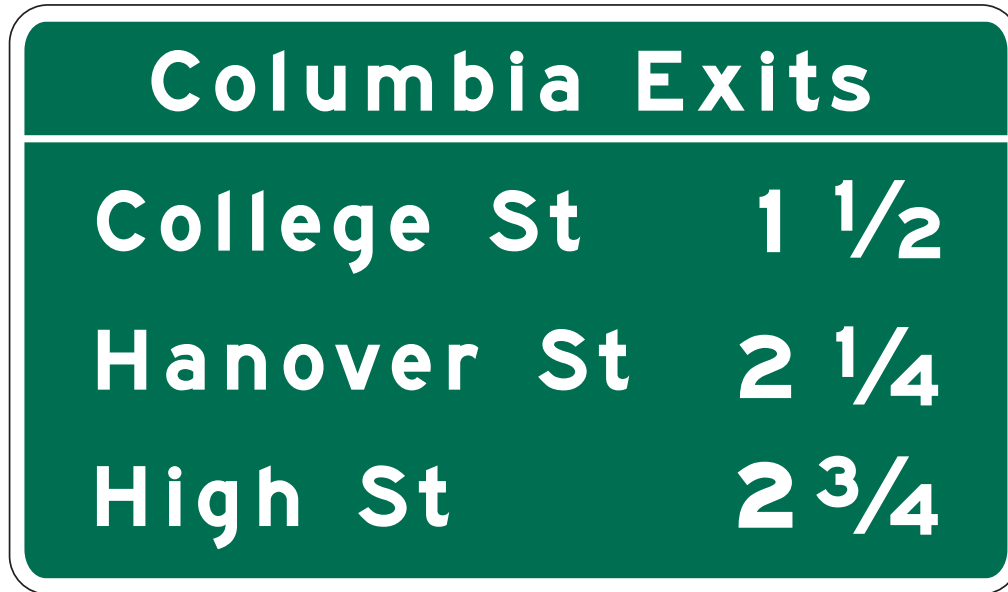

SIZE CODE B IS INTENDED FOR USE ON EXPRESSWAYS

SIZE CODE	DIMENSIONS (MILLIMETERS)							
	LETTER SIZE			VERT. DIMENSION		BORDER WIDTH	CORNER RADIUS	
	PLACE	NUM.	FRACT	3 LINE	4 LINE		2 LINE	3 LINE
B	265/200	265	200	1650	2100	38	150	300
C	332/250	332	250	2100	2700	50	225	300

SIZE CODE	DIMENSIONS (INCHES)							
	LETTER SIZE			VERT. DIMENSION		BORDER WIDTH	CORNER RADIUS	
	PLACE	NUM.	FRACT	3 LINE	4 LINE		3 LINE	4 LINE
B	10.6/8	10.6	8	66	84	1 1/2	6	12
C	13.3/10	13.3	10	84	108	2	9	12

COLORS

LEGEND — WHITE (REFL)
BACKGROUND — GREEN (REFL)

E9-1

1/06



SIZE CODE	DIMENSIONS (MILLIMETERS)							
	A	B	C	D	E	F	G	H
B	VA	1200	38	265	200	200E	237	150
C	VA	1500	50	332	250	250E	300	225

SIZE CODE	DIMENSIONS (INCHES)							
	A	B	C	D	E	F	G	H
B	VA	48	1 1/2	10.6	8	8E	9 1/2	6
C	VA	60	2	13.3	10	10E	12	9

COLORS

LEGEND — WHITE (REFL)
 BACKGROUND — GREEN (REFL)

E11-1

1/06

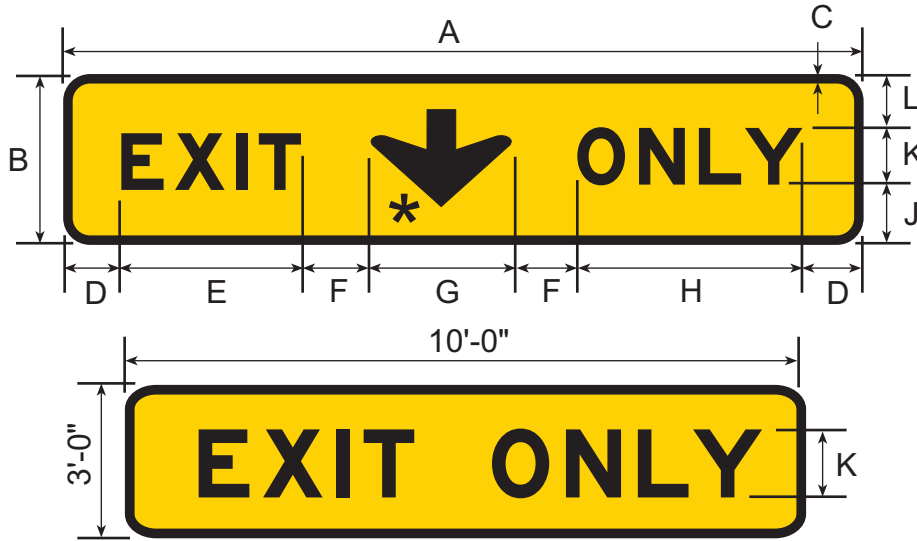

E11-1A

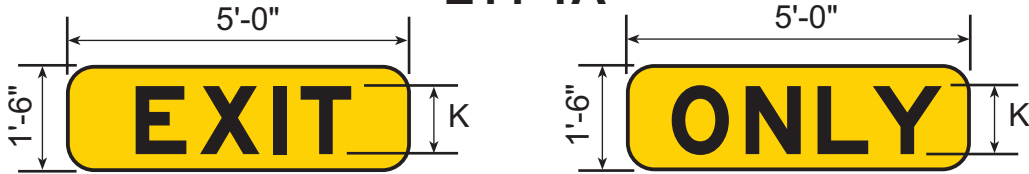

E11-1B

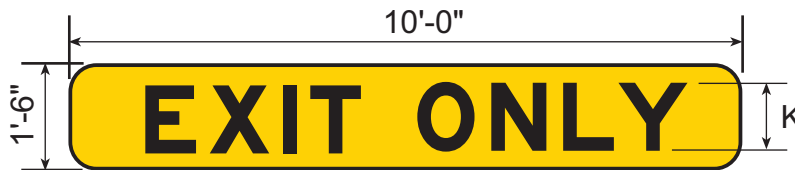

* SEE APPENDIX FOR STANDARD ARROW DETAILS

SIZE CODE	DIMENSIONS (MILLIMETERS)											ARROW NO.
	A	B	C	D	E	F	G	H	J	K	L	
VAR	4200	900	50	300	975	300	800	1225	350	300E	250	8

SIZE CODE	DIMENSIONS (INCHES)											ARROW NO.
	A	B	C	D	E	F	G	H	J	K	L	
VAR	168	36	2	12	39	12	32	49	14	12E	10	8

COLORS

LEGEND — BLACK (NON-REFL)
BACKGROUND — YELLOW (REFL)

E12-101

11/97



E12-201



NOTE: DIMENSIONS TYPICAL BOTH SIGNS

SIGN	DIMENSIONS (MILLIMETERS)					
	A	B	C	D	E	F
STD.	900	600	13	150C	88	56

SIGN	DIMENSIONS (INCHES)					
	A	B	C	D	E	F
STD.	36	24	1/2	6C	3 1/2	2 1/4

COLORS

LEGEND — WHITE (REFL)
BACKGROUND — GREEN (REFL.)

E13-1

11/97

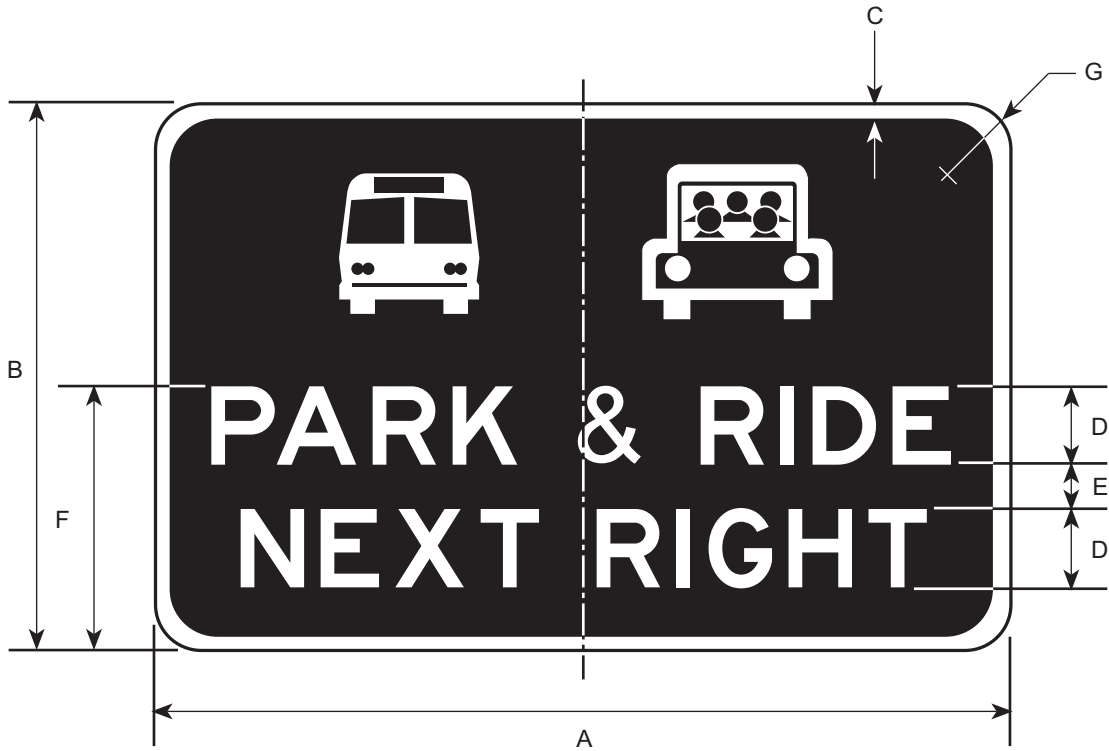

SIGN	DIMENSIONS (MILLIMETERS)						
	A	B	C	D	E	F	G
STD.	2100	1200	31	200E	138	700	75

SIGN	DIMENSIONS (INCHES)						
	A	B	C	D	E	F	G
STD.	84	48	1 1/4	8E	5 1/2	28	3

SEE PLANS FOR REQUIRED BUS AND CARPOOL SYMBOLS

BUS AND CARPOOL SIGNS ARE OPTIONAL. IF USED INDEPENDENTLY, SYMBOL WILL BE PLACED ON THE UPPER LEFT OF SIGN.

COLORS

LEGEND — WHITE (REFL)
BACKGROUND — GREEN (REFL.)

E13-2

1/06

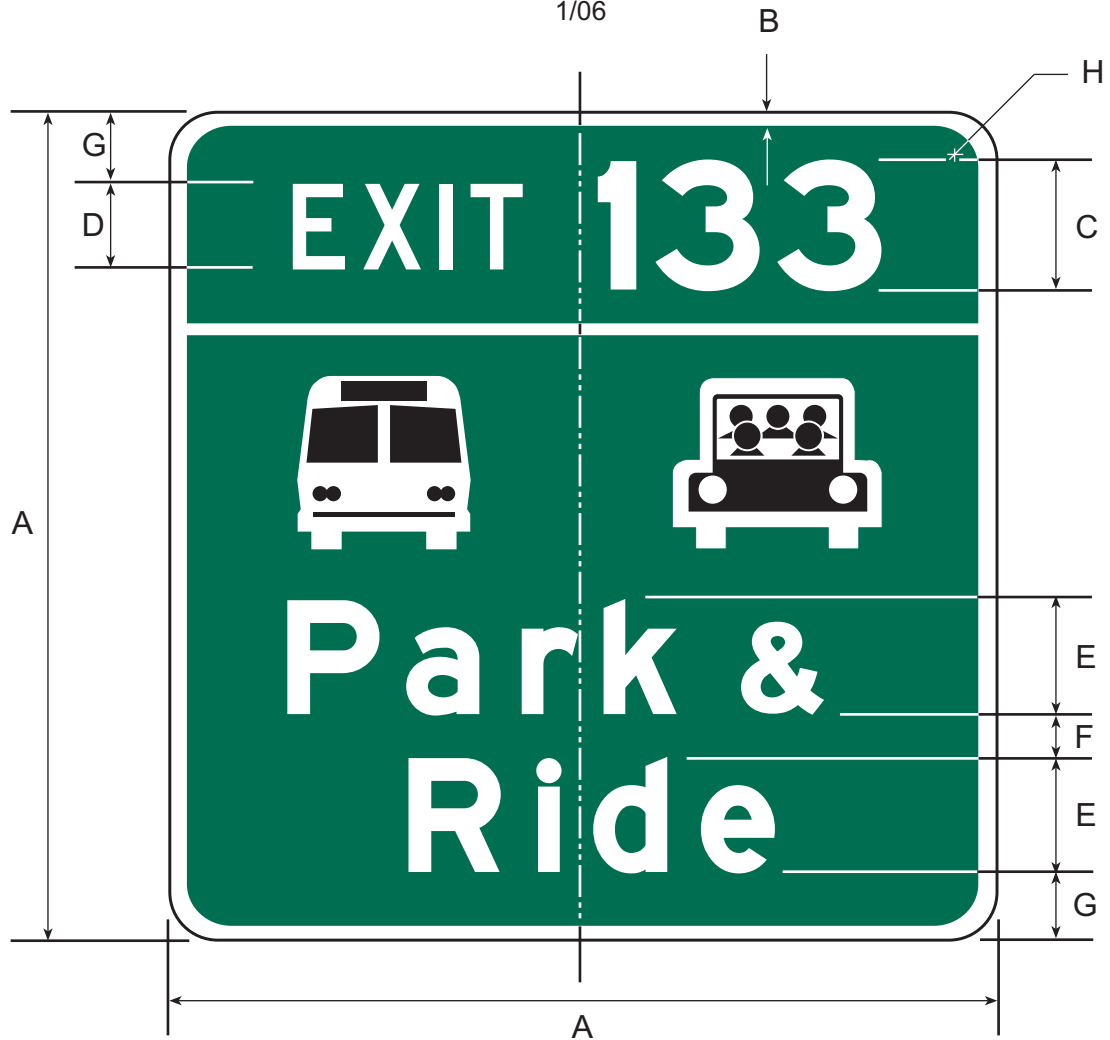

DIMENSIONS (MILLIMETERS)							
A	B	C	D	E	F	G	H
2400	38	375E	250E	333/250E(M)	200	250	100

DIMENSIONS (INCHES)							
A	B	C	D	E	F	G	H
96	1 1/2	15E	10E	13.3/10E(M)	8	10	4

SEE PLANS FOR REQUIRED BUS AND CARPOOL SYMBOLS
 BUS AND CARPOOL SIGNS ARE OPTIONAL. IF USED INDEPENDENTLY,
 PLACE SYMBOL ON THE UPPER LEFT OF SIGN.

COLORS

LEGEND— WHITE (REFL)
 BACKGROUND— GREEN (REFL)

G28-201

5/06

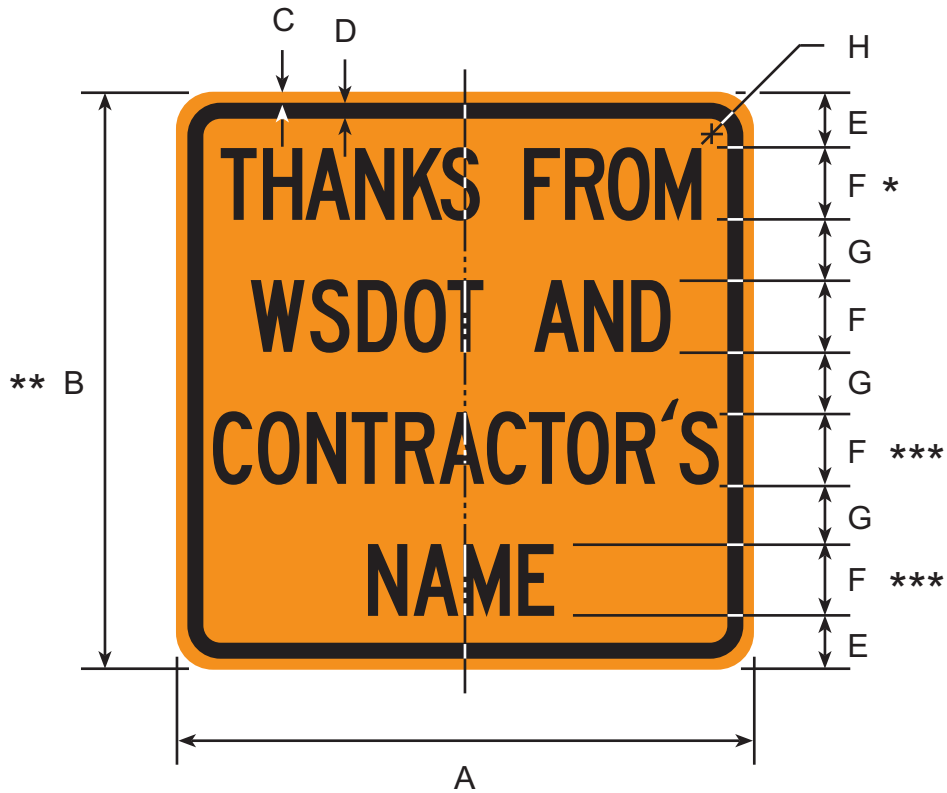

- * - REDUCE SPACING 30%
- ** - IF CONTRACTOR'S NAME ONLY REQUIRES ONE LINE OF COPY REDUCE DIMENSION B TO 900mm (36")
- *** - MAXIMUM OF TEN LETTER CHARACTERS PER LINE, IF CONTRACTOR'S NAME EXCEEDS TEN CHARACTERS PER LINE REDUCE LETTER SIZE TO 125C (5C)

DIMENSIONS (MILLIMETERS)							
A	B	C	D	E	F	G	H
1200	1200	19	150C	113	150	125	75

DIMENSIONS (INCHES)							
A	B	C	D	E	F	G	H
48	48	3/4	6C	4 1/2	150	5	3

COLORS

LEGEND & BORDER - BLACK (NON-REFL)
 BACKGROUND - ORANGE (REFL)

I8-301

1/06

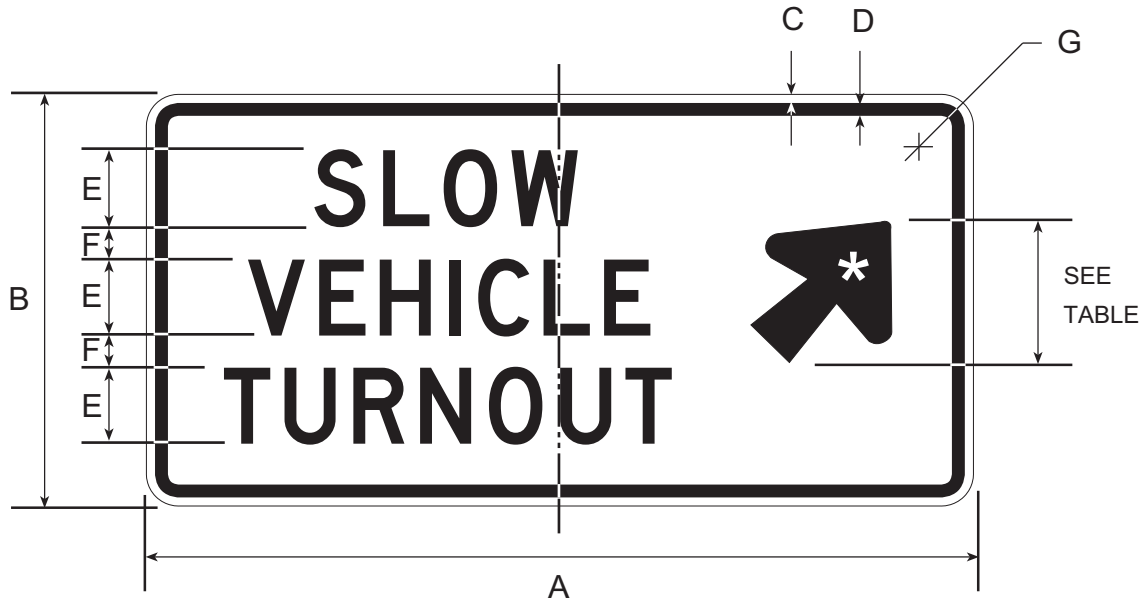

* SEE APPENDIX FOR ARROW DETAILS

DIMENSIONS (MILLIMETERS)							
A	B	C	D	E	F	ARROW SIZE	G
1800	900	19	31	150D	100	NO. 1	100

DIMENSIONS (INCHES)							
A	B	C	D	E	F	ARROW SIZE	G
72	36	3/4	1 1/4	6D	4	NO. 1	4

COLORS

LEGEND — BLACK (NON-REFL)
 BACKGROUND — WHITE (REFL)

I8-401

11/97

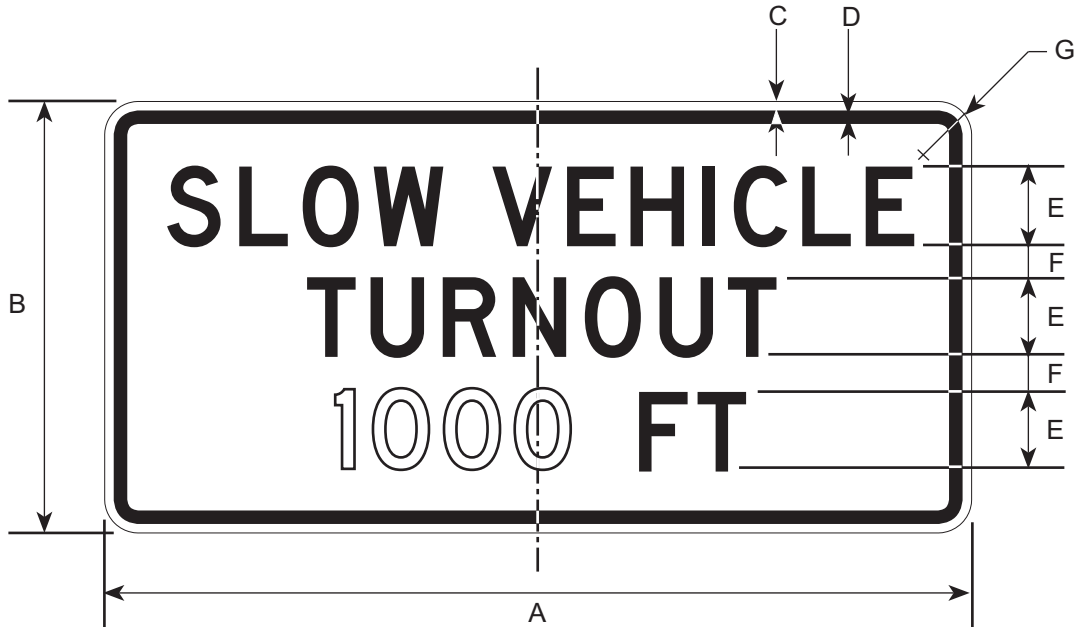

DIMENSIONS (MILLIMETERS)						
A	B	C	D	E	F	G
1800	900	19	31	150D	100	100

DIMENSIONS (INCHES)						
A	B	C	D	E	F	G
72	36	3/4	1 1/4	6D	4	4

COLORS

LEGEND — BLACK (NON-REFL)
 BACKGROUND — WHITE (REFL)

18-708

2/06

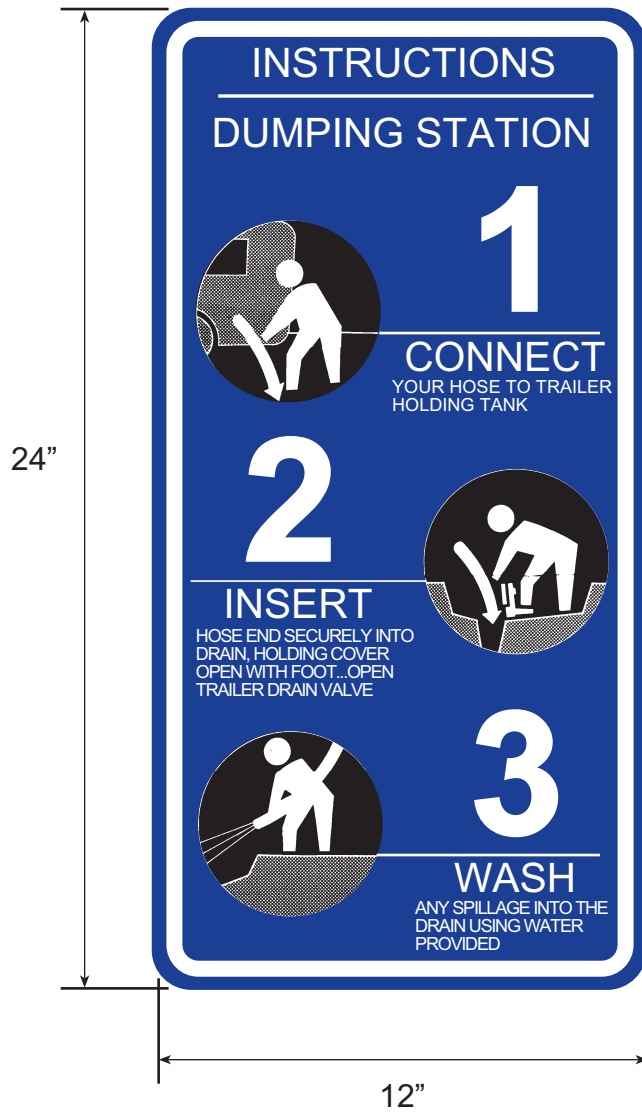

NOTE: CONTACT STATE SIGN SHOP FOR DETAILS

COLORS

LEGEND - WHITE (REFL)
BACKGROUND - BLUE (REFL)

18-709

11/97

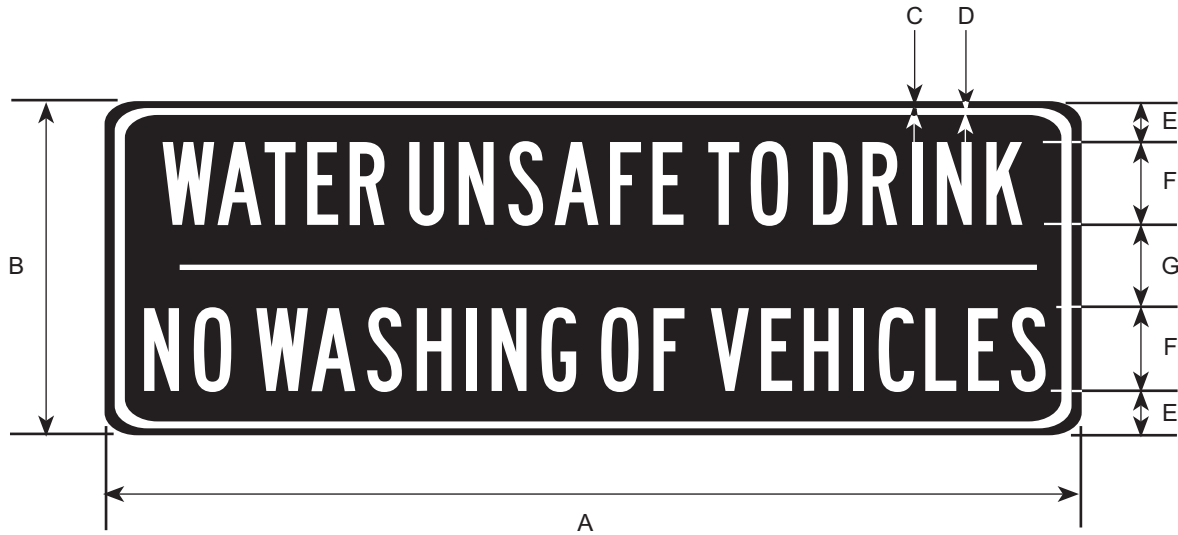

DIMENSIONS (MILLIMETERS)						
A	B	C	D	E	F	G
300	150	6	6	25	25C	50

DIMENSIONS (INCHES)						
A	B	C	D	E	F	G
12	6	1/4	1/4	1	1C	2

COLORS

LEGEND — WHITE (REFL)
BACKGROUND — BLUE (REFL)

I25-101

2/06

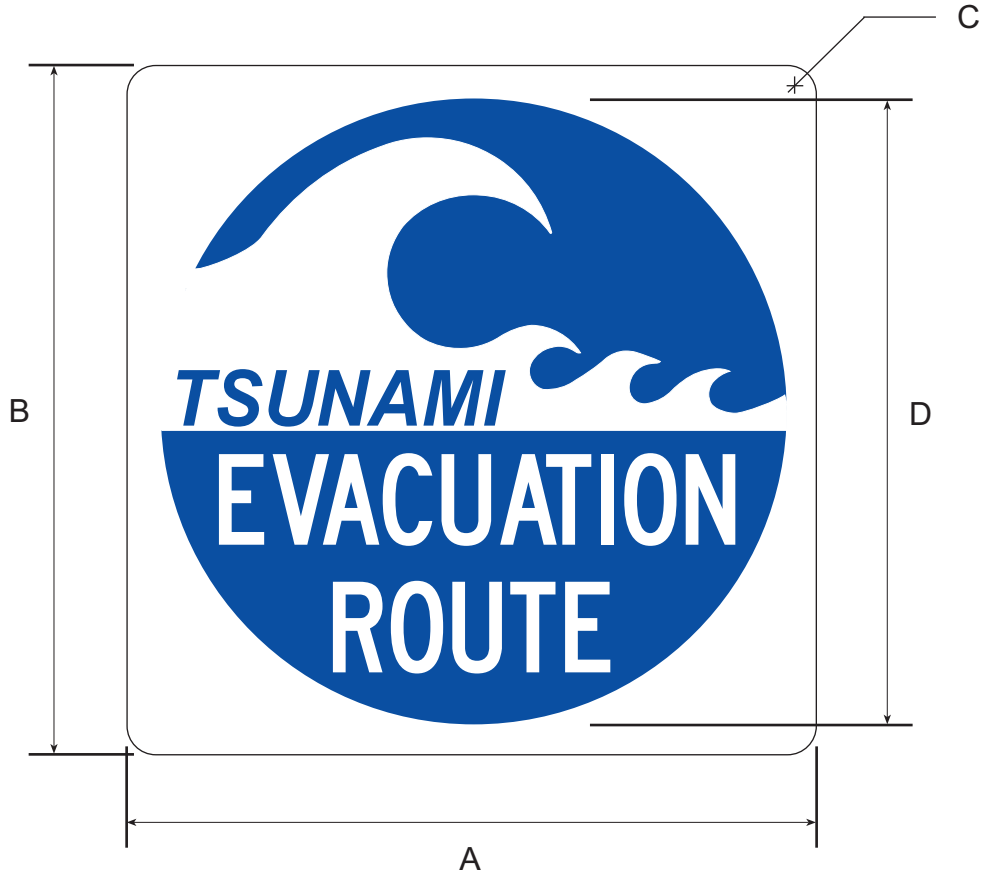

DIMENSIONS (MM)			
A	B	C	D
600	600	38	550

DIMENSIONS (INCHES)			
A	B	C	D
24	24	1 1/2	22

NOTE: CONTACT STATE SIGN SHOP FOR DETAILS

COLORS

LEGEND — WHITE (REFL)
 BACKGROUND — BLUE (REFL) & WHITE (REFL)

I25-102

6/00

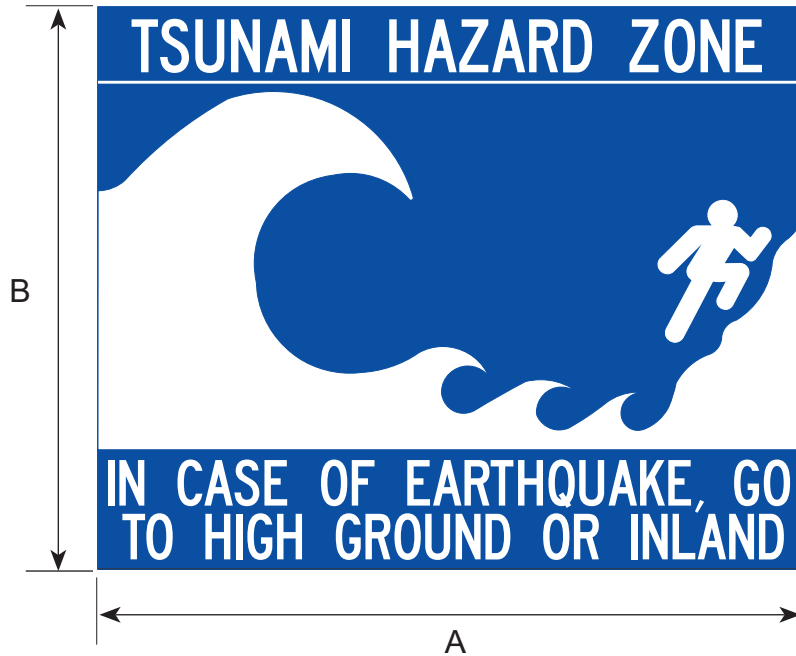

DIMENSIONS (MILLIMETERS)	
A	B
750	600

DIMENSIONS (INCHES)	
A	B
30	24

NOTE: CONTACT STATE SIGN SHOP FOR DETAILS

COLORS

LEGEND — WHITE (REFL)
BACKGROUND — BLUE (REFL)

I25-201

1/06



DIMENSIONS (MM)			
A	B	C	D
600	600	38	550

DIMENSIONS (INCHES)			
A	B	C	D
24	24	1 1/2	22

NOTE: CONTACT STATE SIGN SHOP FOR DETAILS

COLORS

LEGEND — WHITE (REFL)
BACKGROUND — BLUE (REFL)

I35-101

2/06

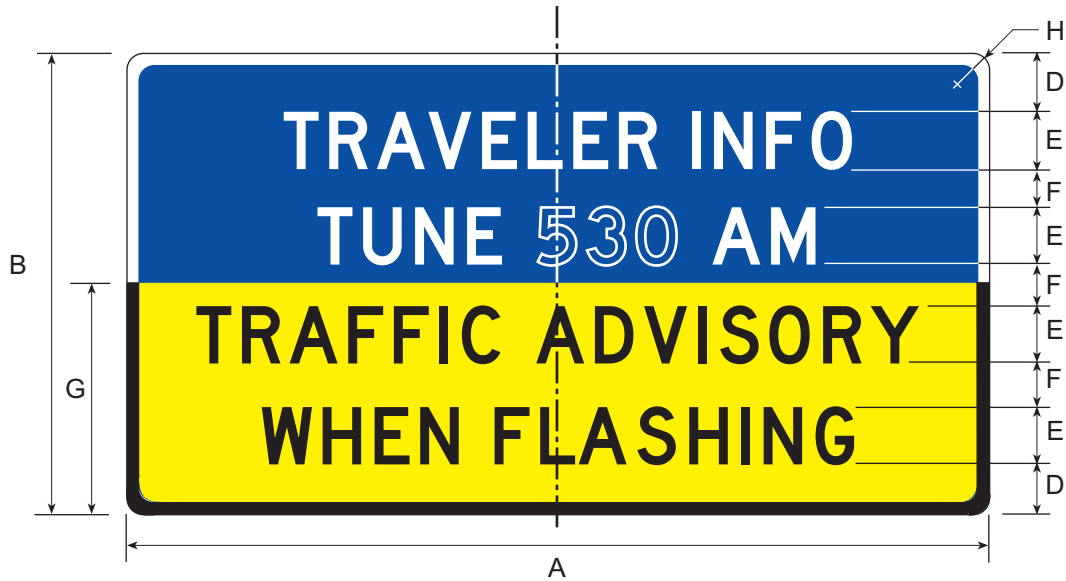

DIMENSIONS (MILLIMETERS)							
A	B	C	D	E	F	G	H
2400	1200	25	150	150D	100	600	150
3000	1800	38	200	200D	150	900	225
3900	2100	38	250	250D	200	1050	263
4500	2400	50	300	300D	200	1200	300

DIMENSIONS (INCHES)							
A	B	C	D	E	F	G	H
96	48	1	6	6D	4	24	6
120	72	1 1/2	8	8D	6	36	9
156	84	1 1/2	10	10D	8	42	10 1/2
180	96	2	12	12D	8	48	12

COLORS

TOP
 LEGEND - WHITE (REFL)
 BACKGROUND - BLUE (REFL)

BOTTOM
 LEGEND - BLACK (NON-REFL)
 BACKGROUND - YELLOW (REFL)

I35-102

8/03



DIMENSIONS (MILLIMETERS)								
A	B	C	D	E	F	G	H	J
1500	900	25	150	150D	300	525	225	100

DIMENSIONS (INCHES)								
A	B	C	D	E	F	G	H	J
60	36	1	6	6D	12	21	9	4

COLORS

LEGEND - WHITE (REFL)
BACKGROUND - BLUE (REFL)

LG-M1

5/06

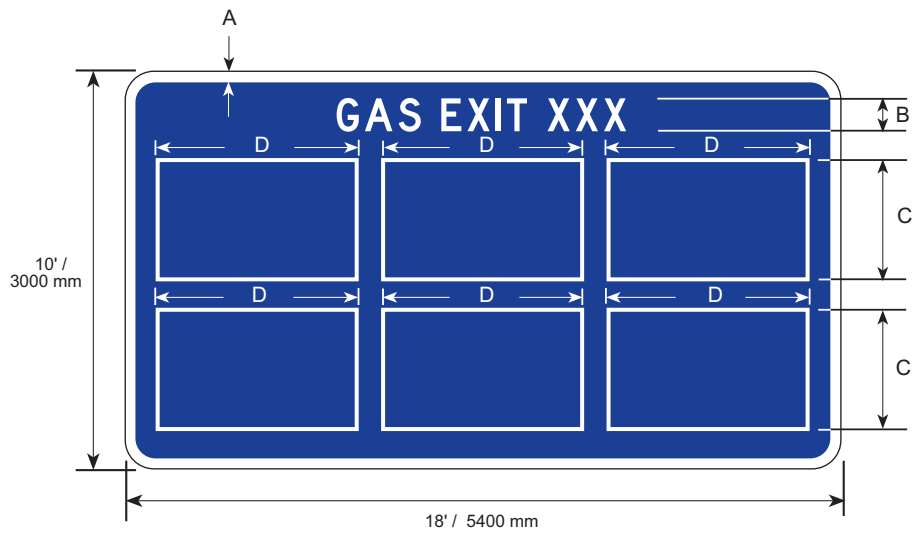
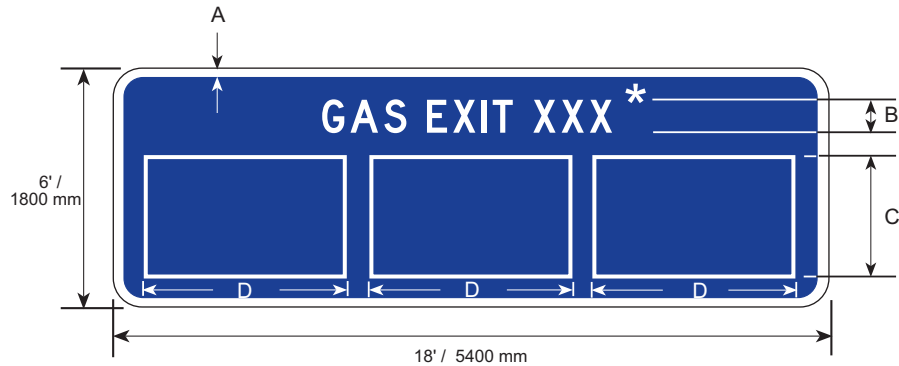

* FOR INTERCHANGES WITHOUT EXIT NUMBERS, USE "NEXT RIGHT"

DIMENSIONS (MILLIMETERS)			
A	B	C	D
38	250D	900	1500

DIMENSIONS (INCHES)			
A	B	C	D
1 1/2	10D	36	60

TYPICAL SIGN (GAS) LAYOUTS FOR FREEWAY OR EXPRESSWAY MAINLINE

COLORS

GAS BACKGROUNDS SHALL BE BLUE REFLECTIVE SHEETING
 LEGEND SHALL BE WHITE REFLECTIVE SHEETING

LG-M1A

5/06

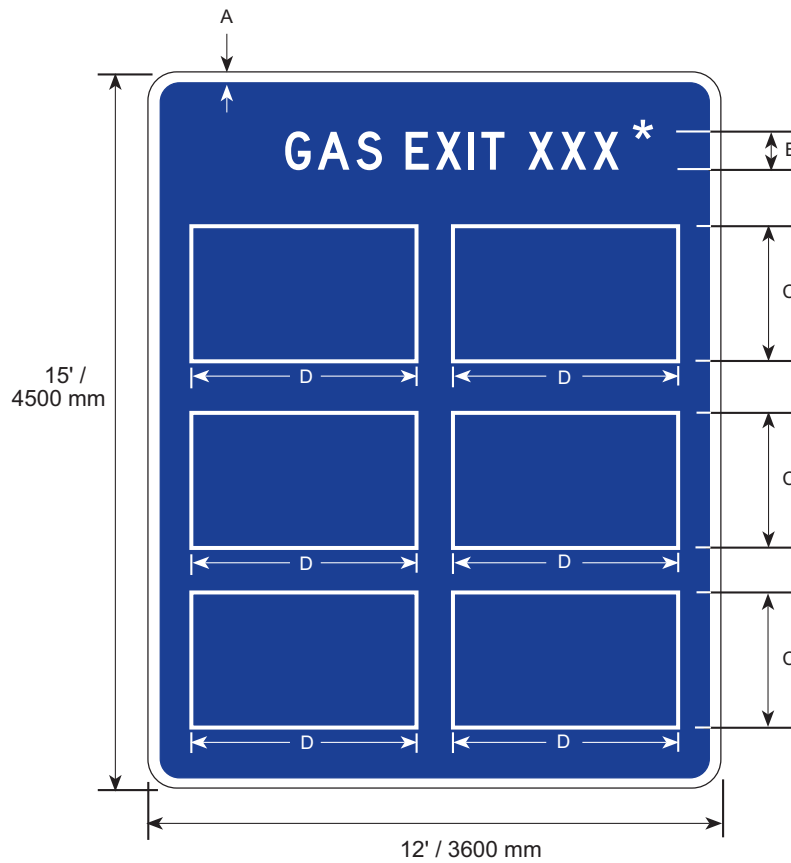

* FOR INTERCHANGES WITHOUT EXIT NUMBERS USE "NEXT RIGHT"

DIMENSIONS (MILLIMETERS)			
A	B	C	D
38	250D	900	1500

DIMENSIONS (INCHES)			
A	B	C	D
1 1/2	10D	36	60

TYPICAL SIGN (GAS) LAYOUTS FOR FREEWAY OR EXPRESSWAY MAINLINE

COLORS

GAS BACKGROUNDS SHALL BE BLUE REFLECTIVE SHEETING
 LEGEND SHALL BE WHITE REFLECTIVE SHEETING

LG-M2

11/97

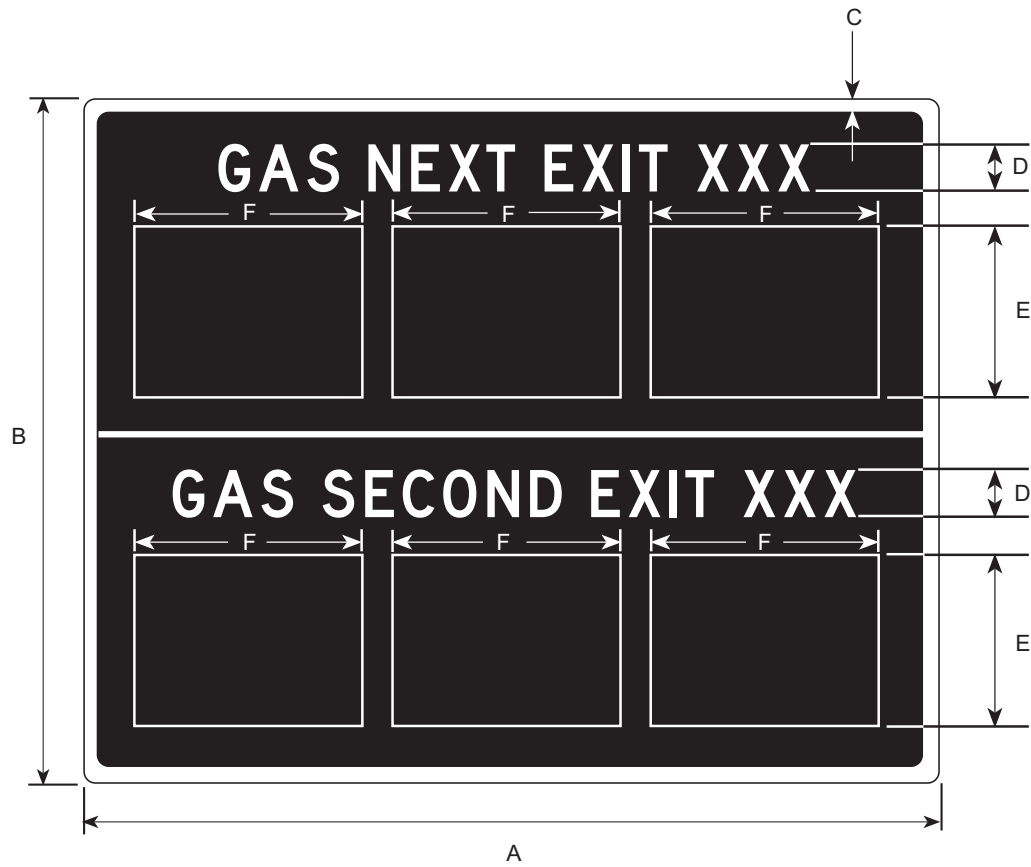

MINIMUM OF 3" BETWEEN BUSINESS SIGNS

DIMENSIONS (MILLIMETERS)					
A	B	C	D	E	F
4500	3600	38	250D	900	1200

DIMENSIONS (INCHES)					
A	B	C	D	E	F
180	144	1 1/2	10D	36	48

TYPICAL SIGN (GAS) LAYOUT FOR FREEWAY OR EXPRESSWAY MAINLINE

GAS BACKGROUND SHALL BE BLUE REFLECTIVE SHEETING. LEGEND SHALL BE WHITE REFLECTIVE SHEETING.

LG-M3

5/06

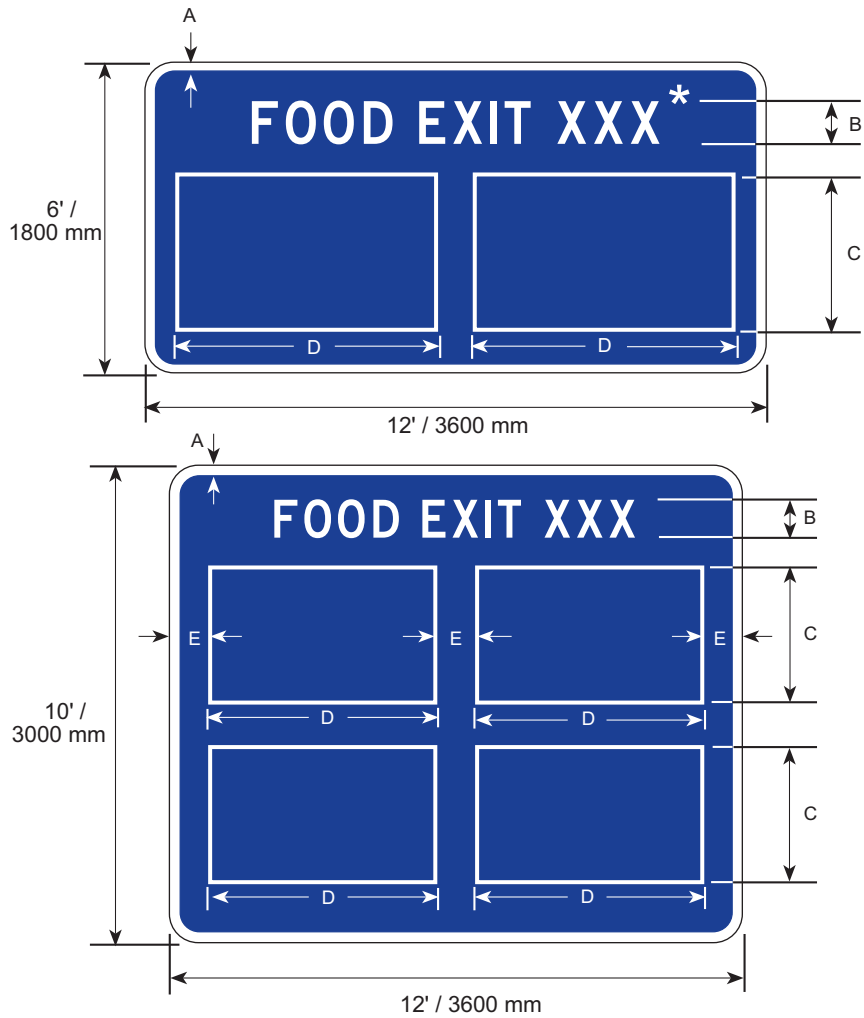

* FOR INTERCHANGES WITHOUT EXIT NUMBERS, USE "NEXT RIGHT"

DIMENSIONS (MILLIMETERS)				
A	B	C	D	E
38	250D	900	1500	200

DIMENSIONS (INCHES)				
A	B	C	D	E
1 1/2	10D	36	60	8

TYPICAL SIGN (FOOD) LAYOUTS FOR FREEWAY OR EXPRESSWAY MAINLINE

COLORS

FOOD BACKGROUNDS SHALL BE BLUE REFLECTIVE SHEETING
 LEGEND SHALL BE WHITE REFLECTIVE SHEETING

LG-M3A

5/06

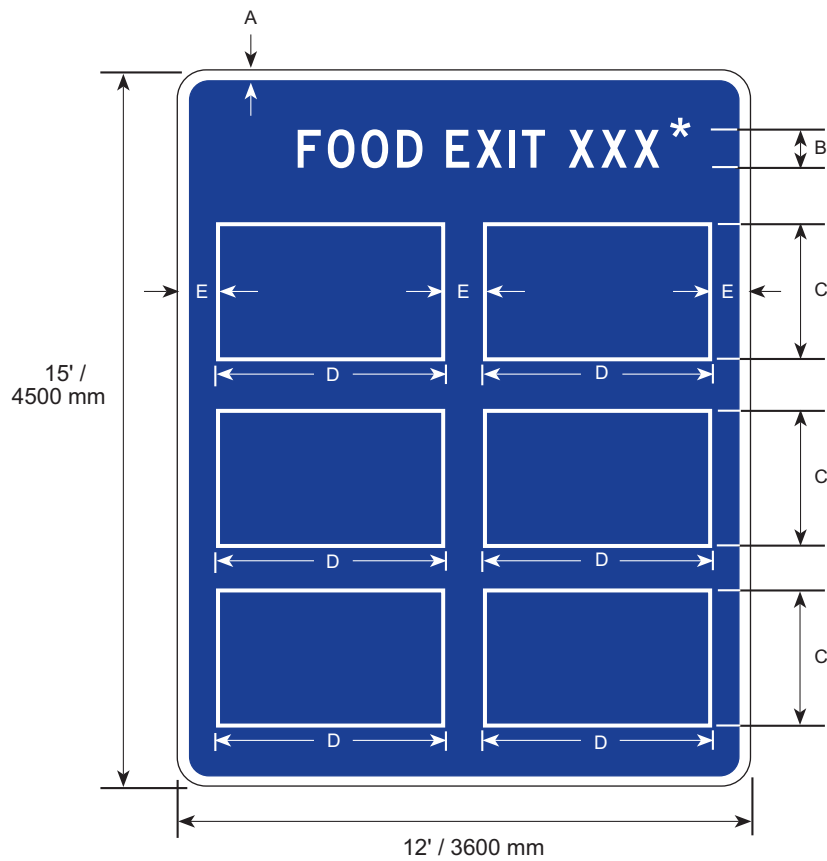

* FOR INTERCHANGES WITHOUT EXIT NUMBERS USE "NEXT RIGHT"

DIMENSIONS (MILLIMETERS)				
A	B	C	D	E
38	250D	900	1500	200

DIMENSIONS (INCHES)				
A	B	C	D	E
1 1/2	10D	36	60	8

TYPICAL SIGN (FOOD) LAYOUTS FOR FREEWAY OR EXPRESSWAY MAINLINE

COLORS

FOOD BACKGROUNDS SHALL BE BLUE REFLECTIVE SHEETING
 LEGEND SHALL BE WHITE REFLECTIVE SHEETING

LG-M4

11/97

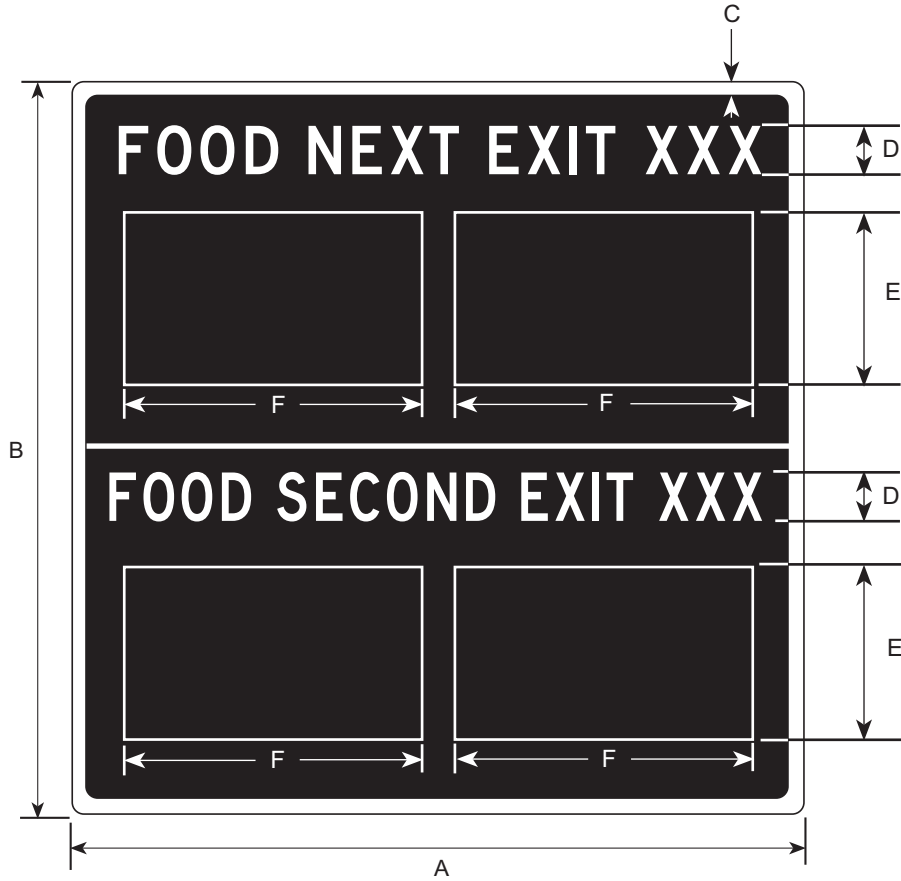

MINIMUM OF 3" BETWEEN BUSINESS SIGNS

DIMENSIONS (MILLIMETERS)					
A	B	C	D	E	F
4200	3600	38	250D	900	1500

DIMENSIONS (INCHES)					
A	B	C	D	E	F
168	144	1 1/2	10D	36	60

TYPICAL SIGN (FOOD) LAYOUT FOR FREEWAY AND EXPRESSWAY MAINLINE.

FOOD BACKGROUNDS SHALL BE BLUE REFLECTIVE SHEETING. LEGEND SHALL BE WHITE REFLECTIVE SHEETING.

LG-M5

5/06

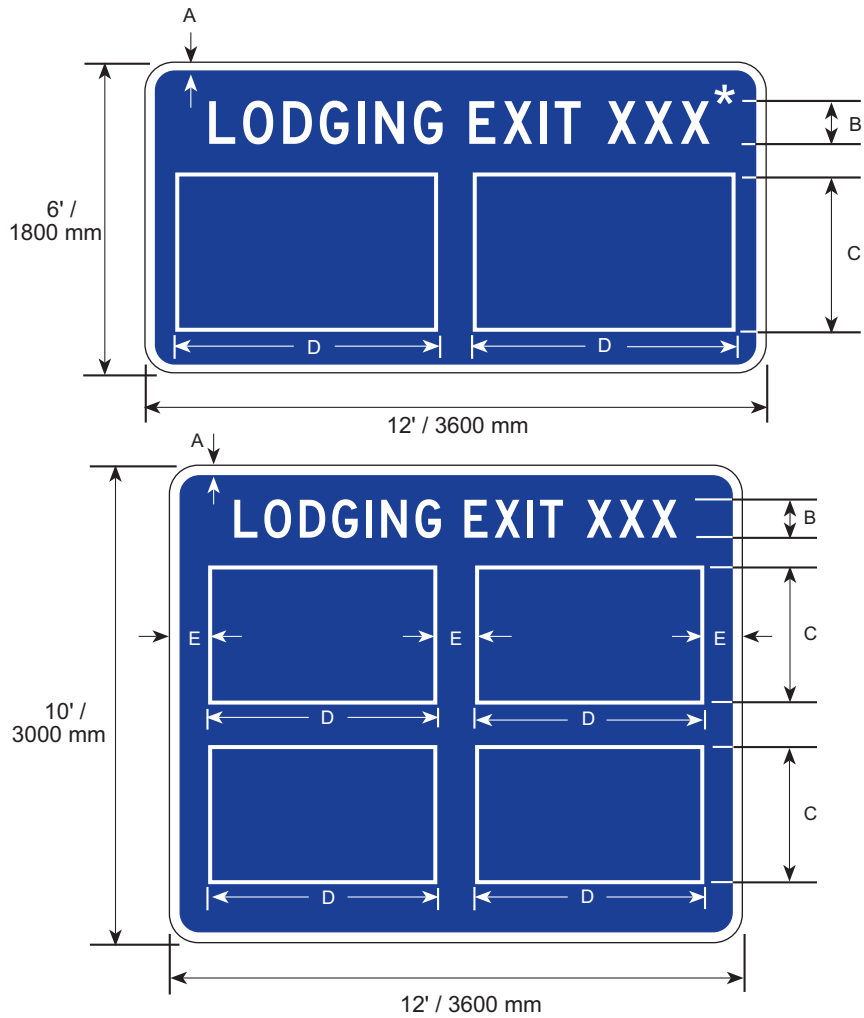

* FOR INTERCHANGES WITHOUT EXIT NUMBERS, USE "NEXT RIGHT"

DIMENSIONS (MILLIMETERS)				
A	B	C	D	E
38	250D	900	1500	200

DIMENSIONS (INCHES)				
A	B	C	D	E
1 1/2	10D	36	60	8

TYPICAL SIGN (LODGING) LAYOUTS FOR FREEWAY OR EXPRESSWAY MAINLINE

COLORS

FOOD BACKGROUNDS SHALL BE BLUE REFLECTIVE SHEETING
 LEGEND SHALL BE WHITE REFLECTIVE SHEETING

LG-M5A

5/06

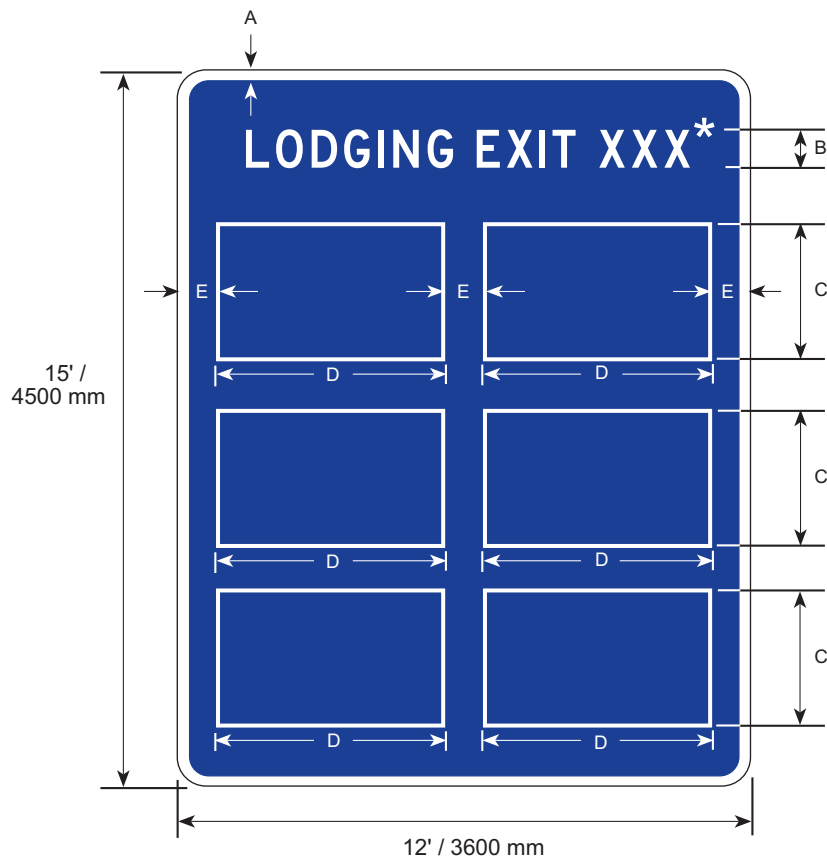

* FOR INTERCHANGES WITHOUT EXIT NUMBERS USE "NEXT RIGHT"

DIMENSIONS (MILLIMETERS)				
A	B	C	D	E
38	250D	900	1500	200

DIMENSIONS (INCHES)				
A	B	C	D	E
1 1/2	10D	36	60	8

TYPICAL SIGN (LODGING) LAYOUTS FOR FREEWAY OR EXPRESSWAY MAINLINE

COLORS

FOOD BACKGROUNDS SHALL BE BLUE REFLECTIVE SHEETING
 LEGEND SHALL BE WHITE REFLECTIVE SHEETING

LG-M6

11/97

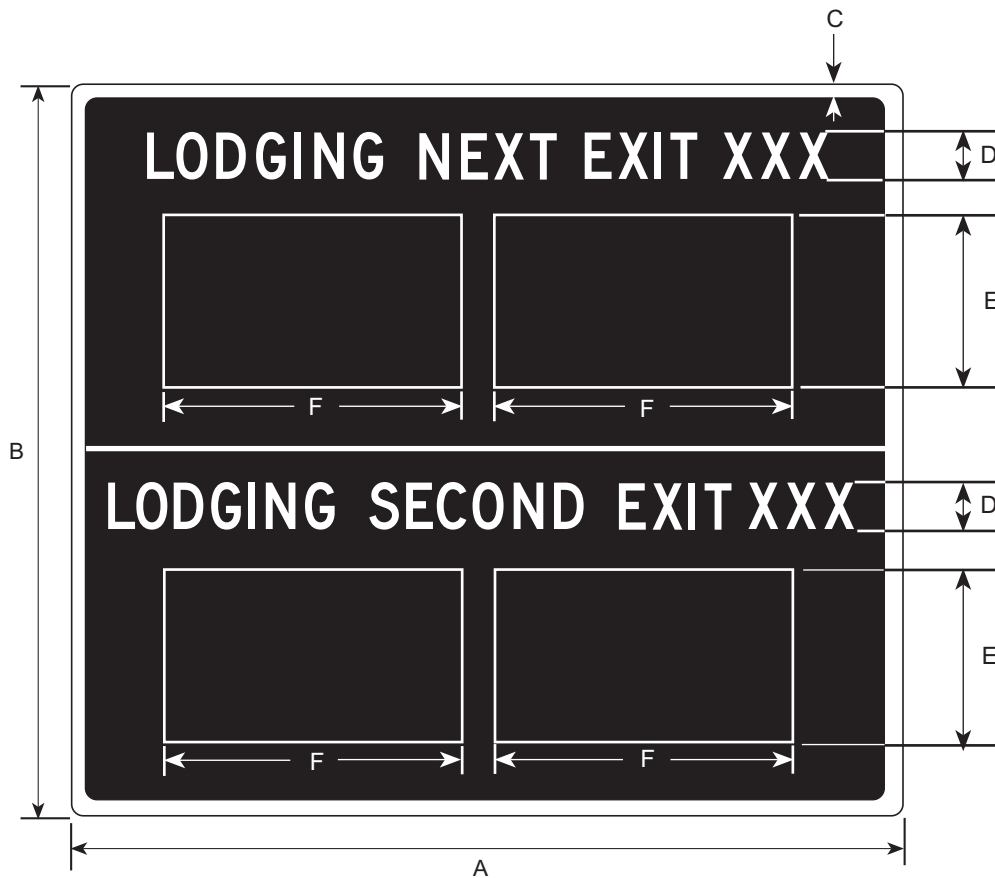

MINIMUM OF 3" BETWEEN BUSINESS SIGNS

DIMENSIONS (MILLIMETERS)					
A	B	C	D	E	F
5100	3600	38	250D	900	1500

DIMENSIONS (INCHES)					
A	B	C	D	E	F
204	144	1 1/2	10D	36	60

TYPICAL SIGN (LODGING) LAYOUT FOR FREEWAY OR EXPRESSWAY MAINLINE.

LODGING BACKGROUNDS SHALL BE BLUE REFLECTIVE SHEETING.
LEGEND SHALL BE WHITE REFLECTIVE SHEETING.

LG-M7

6/00

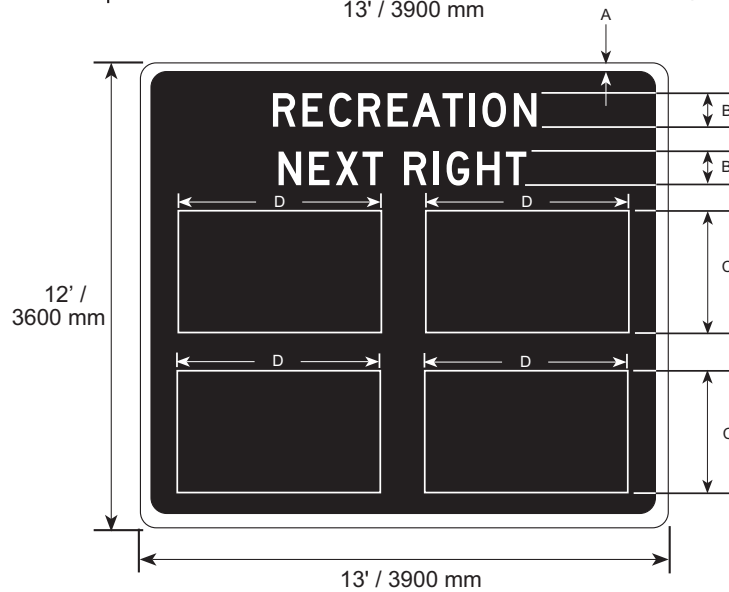
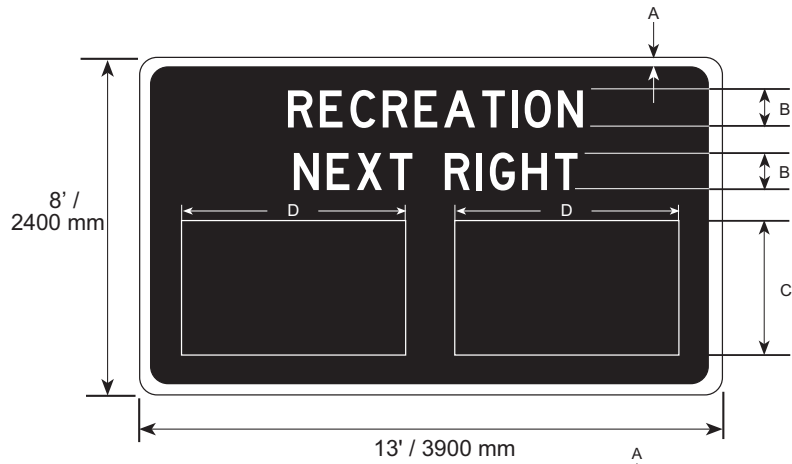

MINIMUM OF 3" BETWEEN BUSINESS SIGNS

DIMENSIONS (MILLIMETERS)			
A	B	C	D
38	250D	900	1500

DIMENSIONS (INCHES)			
A	B	C	D
1 1/2	10D	36	60

RECREATION BACKGROUNDS SHALL BE BROWN REFLECTIVE SHEETING.
LEGEND SHALL BE WHITE REFLECTIVE SHEETING.

LG-M8

11/97

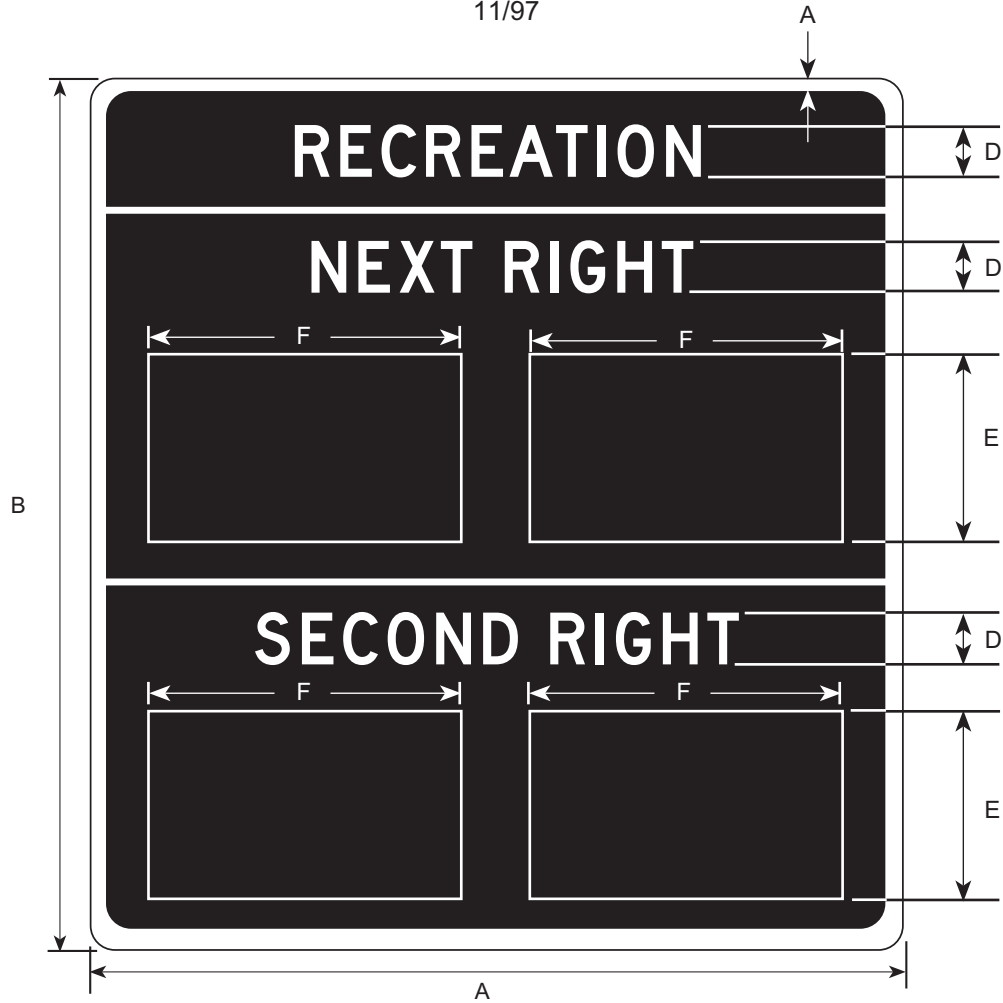

MINIMUM OF 3" BETWEEN BUSINESS SIGNS

DIMENSIONS (MILLIMETERS)					
A	B	C	D	E	F
3900	4200	38	250D	900	1500

DIMENSIONS (INCHES)					
A	B	C	D	E	F
156	168	1 1/2	10D	36	60

RECREATION BACKGROUNDS SHALL BE BROWN REFLECTIVE SHEETING.
 LEGEND SHALL BE WHITE REFLECTIVE SHEETING.

LG-M9

506

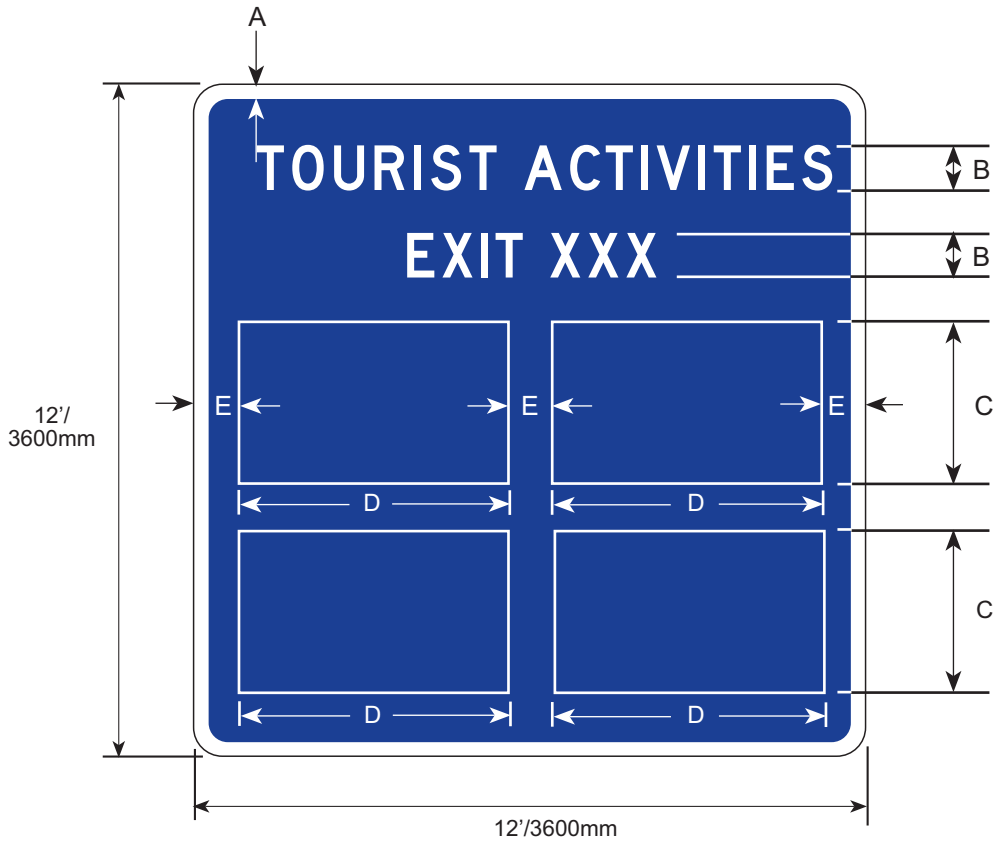

FOR INTERCHANGES WITHOUT EXIT NUMBERS, USE "NEXT RIGHT"

DIMENSIONS (MILLIMETERS)				
A	B	C	D	E
38	250D	900	1500	200

DIMENSIONS (INCHES)				
A	B	C	D	E
1 1/2	10D	36	60	8

TYPICAL SIGN (TOURIST ACTIVITIES) LAYOUT FOR FREEWAY OR EXPRESSWAY MAINLINE

COLORS

TOURIST ACTIVITIES BACKGROUNDS SHALL BE BLUE REFLECTIVE SHEETING
LEGEND SHALL BE WHITE REFLECTIVE SHEETING.

LG-M9A

5/06

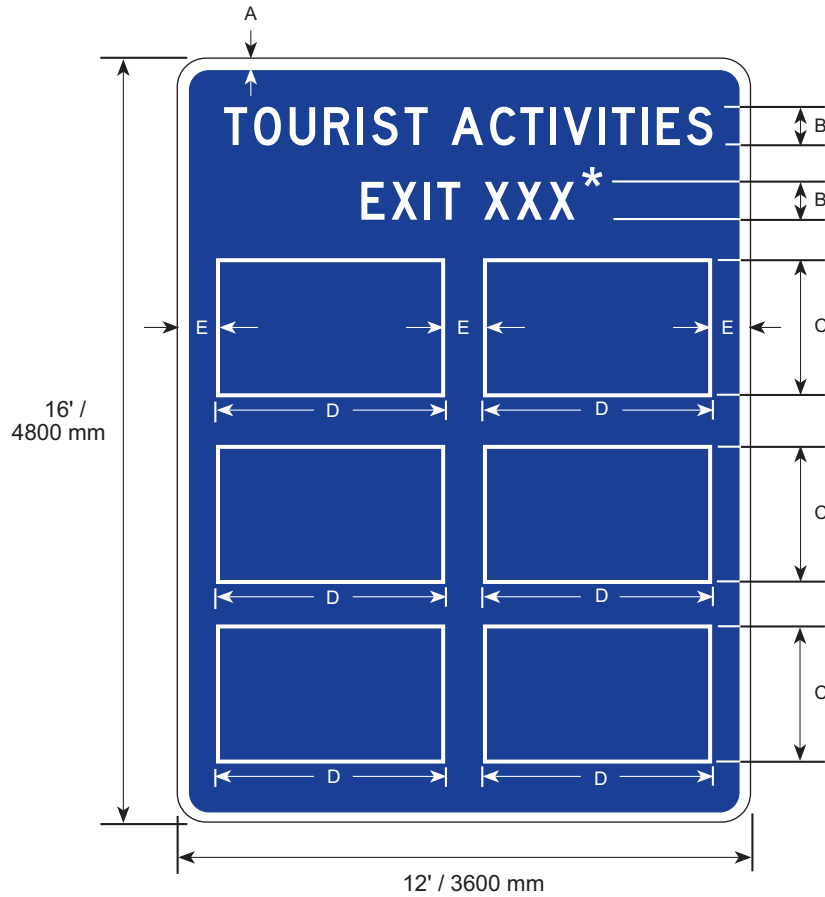

* FOR INTERCHANGES WITHOUT EXIT NUMBERS USE "NEXT RIGHT"

DIMENSIONS (MILLIMETERS)				
A	B	C	D	E
38	250D	900	1500	200

DIMENSIONS (INCHES)				
A	B	C	D	E
1 1/2	10D	36	60	8

TYPICAL SIGN (TOURIST ACTIVITIES) LAYOUTS FOR
FREEWAY OR EXPRESSWAY MAINLINE

COLORS

FOOD BACKGROUNDS SHALL BE BLUE REFLECTIVE SHEETING
LEGEND SHALL BE WHITE REFLECTIVE SHEETING

LG-M10

11/97

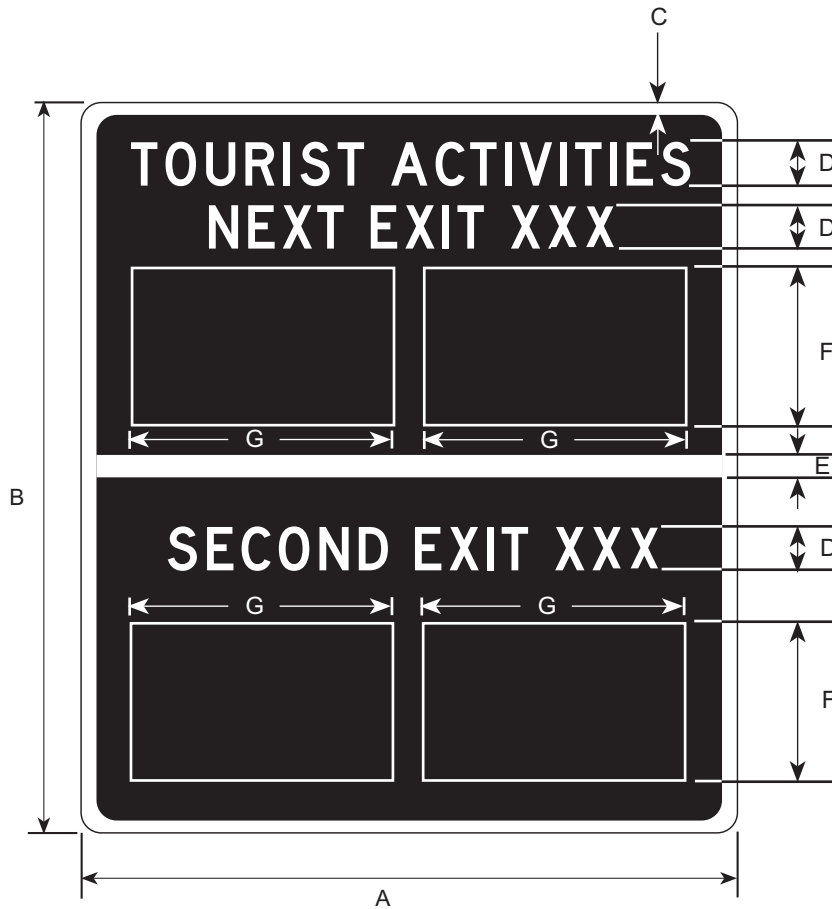

MINIMUM OF 3" BETWEEN BUSINESS SIGNS

DIMENSIONS (MILLIMETERS)						
A	B	C	D	E	F	G
3900	4200	38	250D	50	900	1500

DIMENSIONS (INCHES)						
A	B	C	D	E	F	G
156	168	1 1/2	10D	2	36	60

TYPICAL SIGN (TOURIST ACTIVITIES) LAYOUT FOR FREEWAY AND EXPRESSWAY MAINLINE.

TOURIST ACTIVITIES BACKGROUNDS SHALL BE BLUE REFLECTIVE SHEETING. LEGEND SHALL BE WHITE REFLECTIVE SHEETING.

LG-R1

5/06

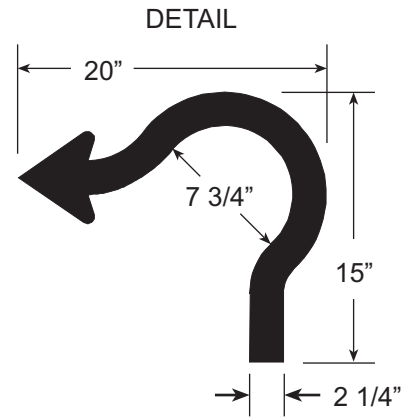
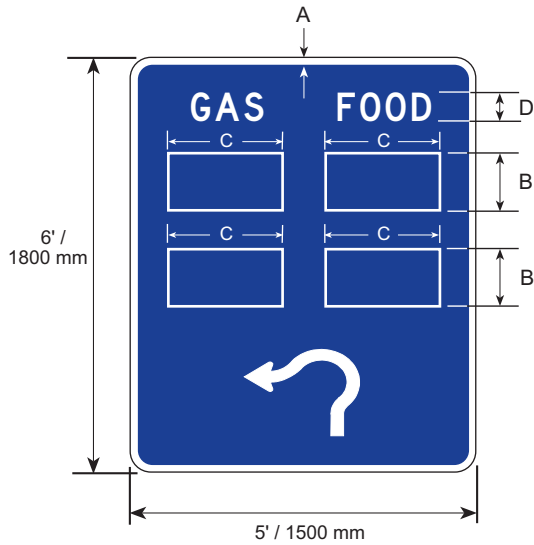
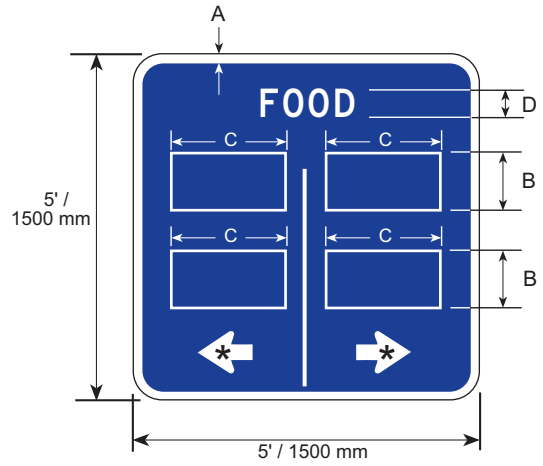
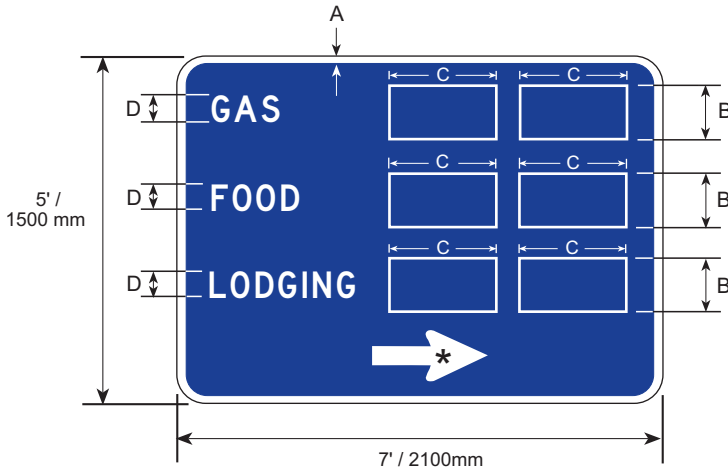

MINIMUM OF 3" BETWEEN BUSINESS SIGNS

* SEE APPENDIX FOR STANDARD ARROW DETAILS

DIMENSIONS (MM)			
A	B	C	D
25	300	600	150D

DIMENSIONS (INCHES)			
A	B	C	D
1	12	24	6D

TYPICAL SIGN (GAS, FOOD, LODGING) LAYOUTS FOR FREEWAY AND EXPRESSWAY RAMPS

GAS, FOOD, AND LODGING BACKGROUNDS SHALL BE BLUE REFLECTIVE SHEETING
 LEGEND SHALL BE WHITE REFLECTIVE SHEETING

LG-R2

2/98

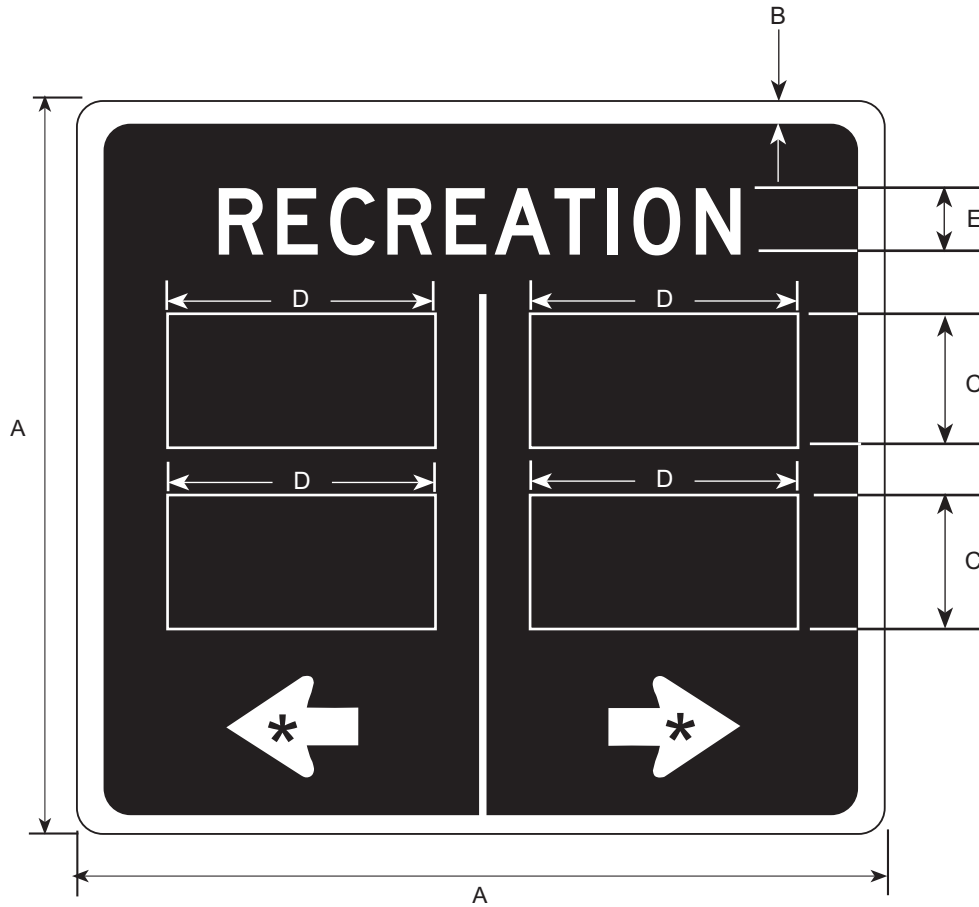

MINIMUM OF 3" BETWEEN BUSINESS SIGNS

* SEE APPENDIX FOR STANDARD ARROW DETAILS

DIMENSIONS (MILLIMETERS)				
A	B	C	D	E
1500	25	300	600	150D

DIMENSIONS (INCHES)				
A	B	C	D	E
60	1	12	24	6D

TYPICAL SIGN (RECREATION) LAYOUT FOR FREEWAY OR EXPRESSWAY RAMP

RECREATION BACKGROUND SHALL BE BROWN REFLECTIVE SHEETING.
LEGEND SHALL BE WHITE REFLECTIVE SHEETING.

LG-R3

2/98

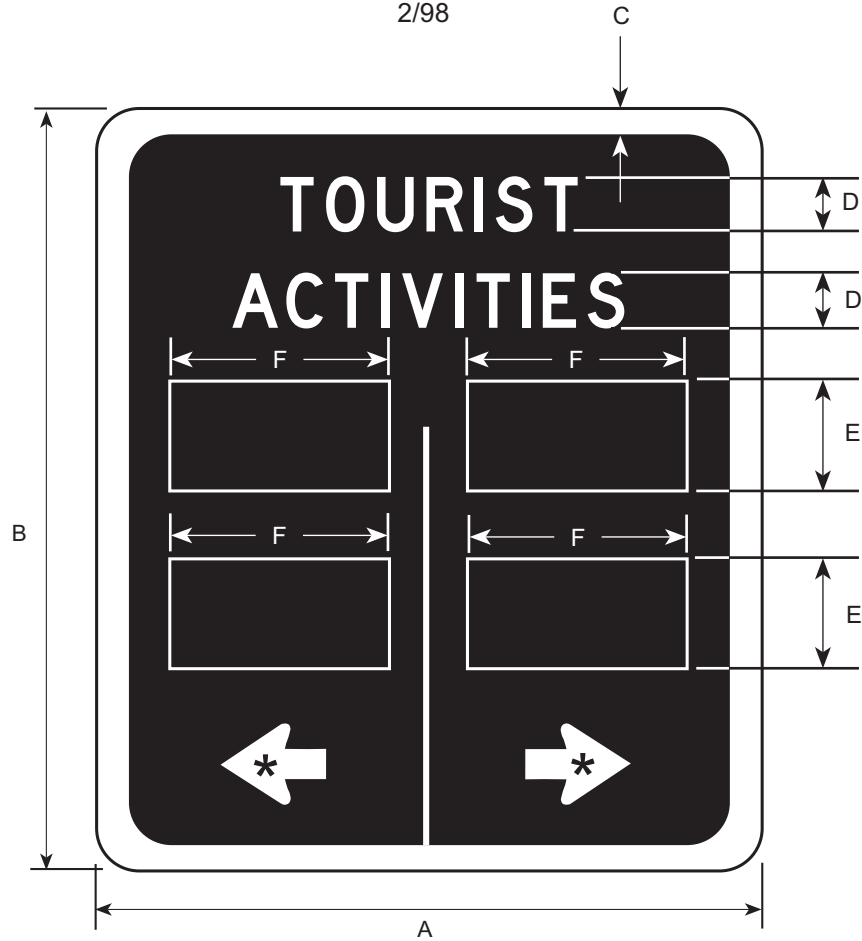

MINIMUM OF 3" BETWEEN BUSINESS SIGNS

* SEE APPENDIX FOR STANDARD ARROW DETAILS

DIMENSIONS (MILLIMETERS)					
A	B	C	D	E	F
1500	1800	25	150D	300	600

DIMENSIONS (INCHES)					
A	B	C	D	E	F
60	72	1	6D	12	24

TYPICAL SIGN (TOURIST ACTIVITIES) LAYOUT FOR FREEWAY OR EXPRESSWAY RAMPS

TOURIST ACTIVITIES BACKGROUND SHALL BE BLUE REFLECTIVE SHEETING. LEGEND SHALL BE WHITE REFLECTIVE SHEETING.

LG-R4

5/06

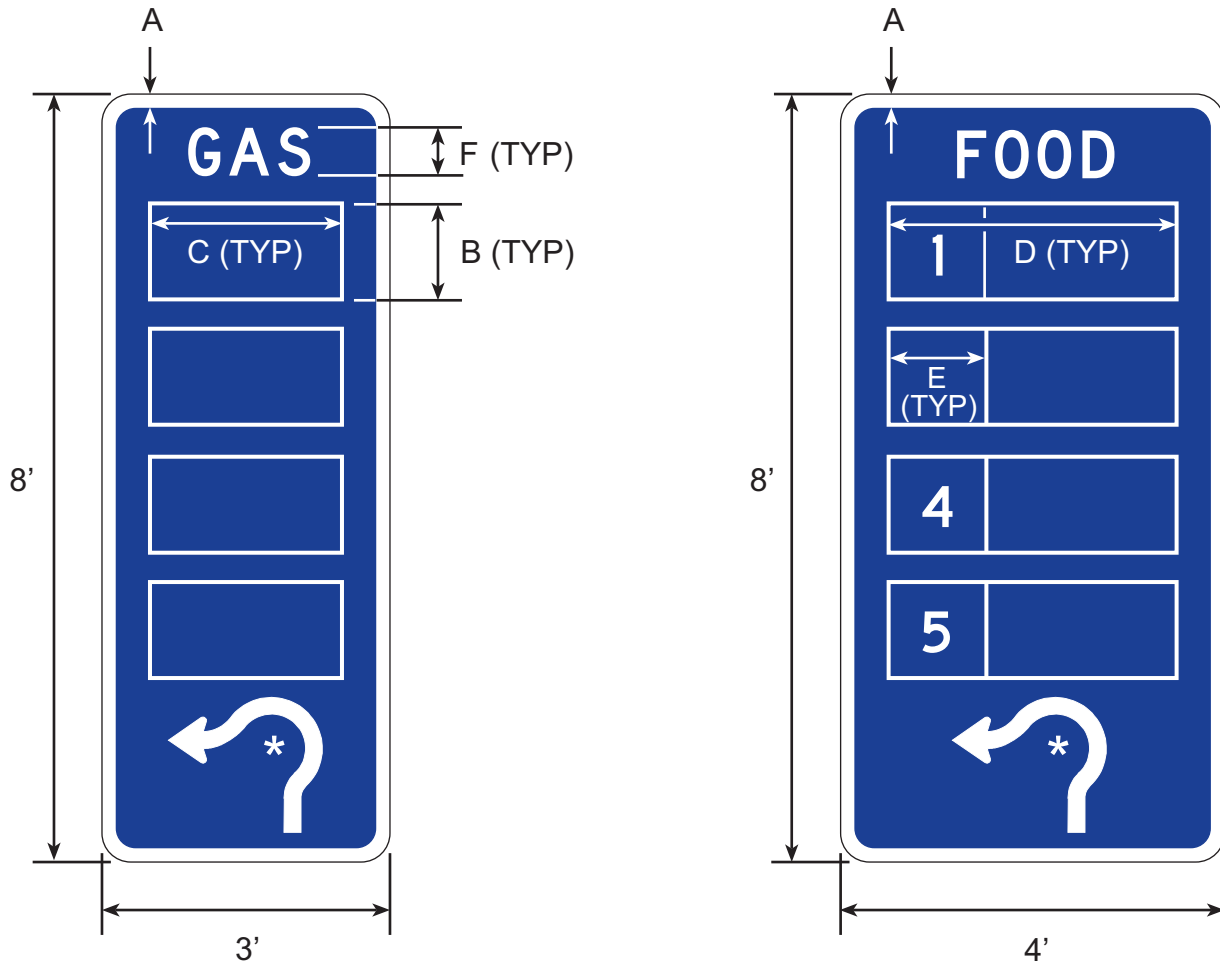

* SEE APPENDIX FOR STANDARD ARROW DETAILS
SEE LG-R1 FOR ARROW DIMENSIONS

DIMENSIONS (MILLIMETERS)					
A	B	C	D	E	F
25	300	600	900	300	150D

DIMENSIONS (INCHES)					
A	B	C	D	E	F
1	12	24	36	12	6D

TYPICAL SIGN (GAS, FOOD, LODGING) LAYOUTS FOR FREEWAY AND EXPRESSWAY RAMP HAVING A ROUNDABOUT

GAS, FOOD, AND LODGING BACKGROUNDS SHALL BE BLUE REFLECTIVE SHEETING
LEGEND SHALL BE WHITE REFLECTIVE SHEETING

M1-3

11/97

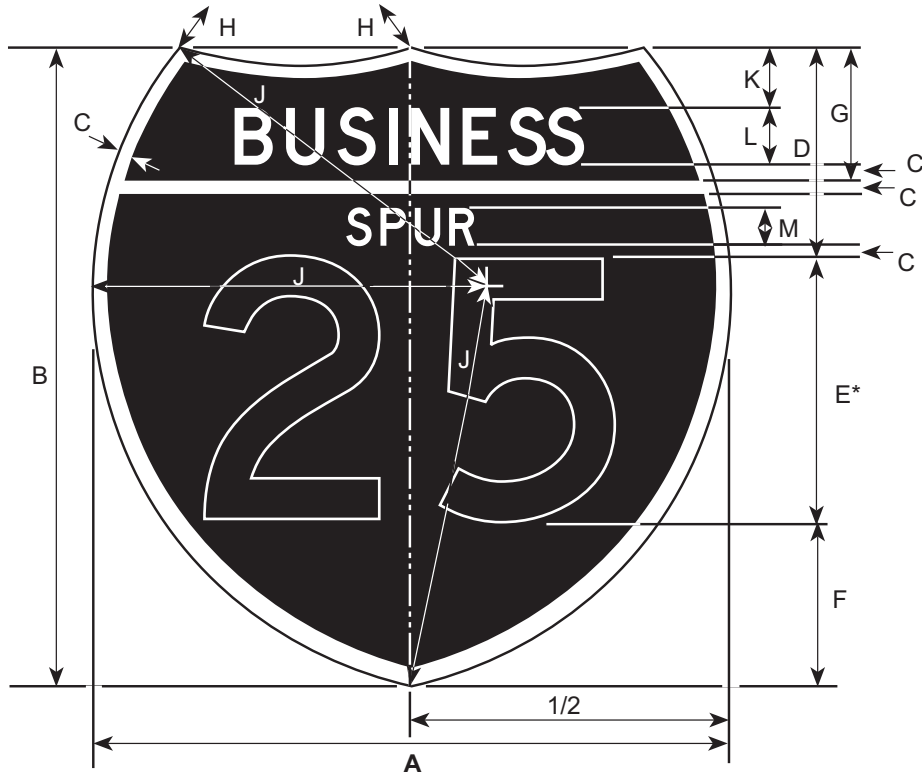

*OPTICALLY SPACE NUMERALS ABOUT VERTICAL CENTERLINE

OFF- INTERSTATE

BUSINESS SPUR MARKER

SIGN	DIMENSIONS (MILLIMETERS)											
	A	B	C	D	E	F	G	H	J	K	L	M
1,2 DIGITS	600	600	325	200	250D	150	125	375	375	50	63C	38D
1,2 DIGITS	900	900	475	300	375D	225	188	563	563	75	94C	56D
1,2 DIGITS	1200	1200	625	400	500D	300	250	750	750	100	125C	75D
3 DIGITS	750	600	325	200	250D	150	125	600	425	50	63C	38D
3 DIGITS	112	900	475	300	375D	225	188	900	638	75	94C	56D
3 DIGITS	1500	1200	625	400	500D	300	250	1200	850	100	125C	75D

SIGN	DIMENSIONS (INCHES)											
	A	B	C	D	E	F	G	H	J	K	L	M
1,2 DIGITS	24	24	1/2	8	10D	6	5	15	15	2	2 1/2C	1 1/2D
1,2 DIGITS	36	36	3/4	12	15D	9	7 1/2	22 1/2	22 1/2	3	3 3/4C	2 1/4D
1,2 DIGITS	48	48	1	16	20D	12	10	30	30	4	5C	3D
3 DIGITS	30	24	1/2	8	10D	6	5	24	17	2	2 1/2C	1 1/2D
3 DIGITS	45	36	3/4	12	15D	9	7 1/2	36	25 1/2	3	3 3/4C	2 1/4D
3 DIGITS	60	48	1	16	20D	12	10	48	34	4	5C	3D

COLORS

LEGEND — WHITE (REFL)
BACKGROUND - GREEN (REFL)

M1-4

5/06

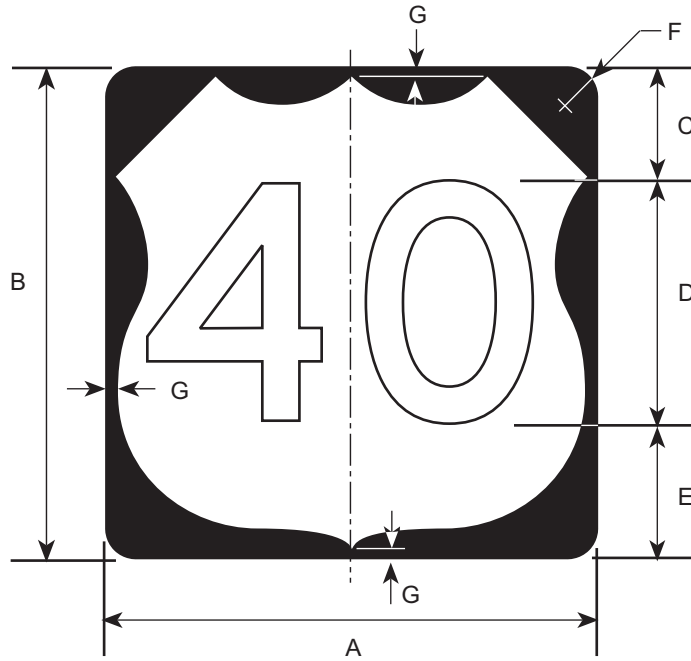

SIGN	DIMENSIONS (MILLIMETERS)						
	A	B	C	D	E	F	G
1,2 DIGIT	600	600	138	300D	163	13	38
1,2 DIGIT	900	900	206	450D	244	19	56
1,2 DIGIT	1200	1200	275	600D	325	25	75
3 DIGIT	750	600	138	300D	163	13	38
3 DIGIT	112	900	206	450D	244	19	56
3 DIGIT	1500	1200	275	600D	325	25	75

SIGN	DIMENSIONS (INCHES)						
	A	B	C	D	E	F	G
1,2 DIGIT	24	24	5 1/2	12D	6 1/2	1/2	1 1/2
1,2 DIGIT	36	36	8 1/4	18D	9 3/4	3/4	2 1/4
1,2 DIGIT	48	48	11	24D	13	1	3
3 DIGIT	30	24	5 1/2	12D	6 1/2	1/2	1 1/2
3 DIGIT	45	36	8 1/4	18D	9 3/4	3/4	2 1/4
3 DIGIT	60	48	11	24D	13	1	3

COLORS

LEGEND & BACKGROUND— BLACK (NON-REFL)
SHIELD— WHITE (REFL)

M1-601

5/06

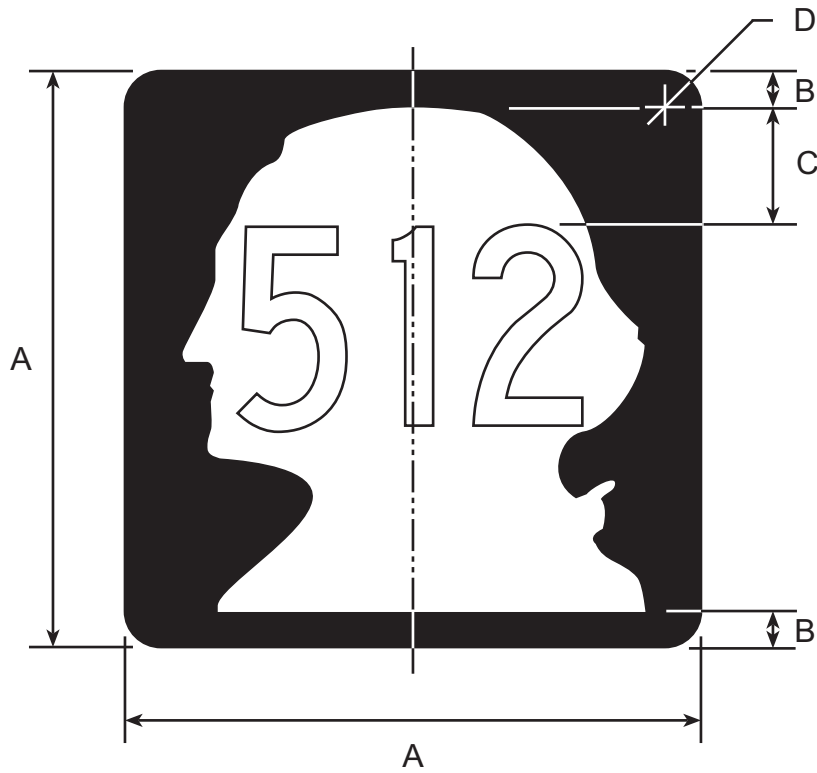

INDEPENDENT (TRAILBLAZER) USE

DIMENSIONS (MILLIMETERS)							
A	B	C	D	SHIELD SIZE	NUMBER SIZE & SERIES		
					1 DIGIT	2 DIGIT	3 DIGIT
600	25	150	38	500 x 550	325C	250C	200C
900	25	238	56	783 x 850	450C	375C	300C

DIMENSIONS (INCHES)							
A	B	C	D	SHIELD SIZE	NUMBER SIZE & SERIES		
					1 DIGIT	2 DIGIT	3 DIGIT
24	1	6	1 1/2	20 x 22	13C	10C	8C
36	1	9 1/2	2 1/4	31 5/16 x 34	18C	15C	12C

COLORS

SHIELD SYMBOL - WHITE (REFL)
 BACKGROUND & NUMBERS - BLACK (NON-REFL)

M1-602

5/06

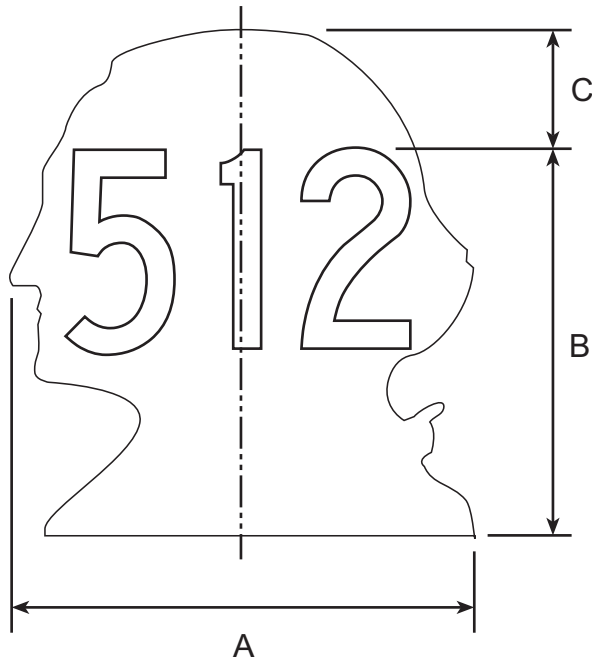

GUIDE SIGN USE

DIMENSIONS (MILLIMETERS)					
A	B	C	NUMBER SIZE & SERIES		
			1 DIGIT	2 DIGIT	3 DIGIT
408	450	125	250C	200C	150C
544	600	166	325C	275C	200C
830	900	250	500C	400C	300C

DIMENSIONS (INCHES)					
A	B	C	NUMBER SIZE & SERIES		
			1 DIGIT	2 DIGIT	3 DIGIT
16 5/16	18	5	10C	8C	6C
21 3/4	24	6 5/8	13C	11C	8C
33 3/16	36	10	20C	16C	12C

COLORS

SHIELD SYMBOL - WHITE REFL)
 NUMBERS - BLACK (NON-REFL)

M1-7

6/00



* OPTICALLY SPACE NUMERALS ABOUT VERTICAL CENTERLINE

DIMENSIONS (MILLIMETERS)								
A	B	C	D	E	F	G	H	J
319	450	13	66	150D	27	100	41	50
425	600	13	88	200D	43	125	56	63

DIMENSIONS (INCHES)								
A	B	C	D	E	F	G	H	J
12 3/4	18	1/2	2 5/8	6D	1 1/8	4	1 5/8	2
17	24	1/2	3 1/2	8D	1 3/4	5	2 1/4	2 1/2

COLORS

LEGEND - WHITE (REFL.)
 BACKGROUND - BROWN (REFL.)

M1-701

5/06

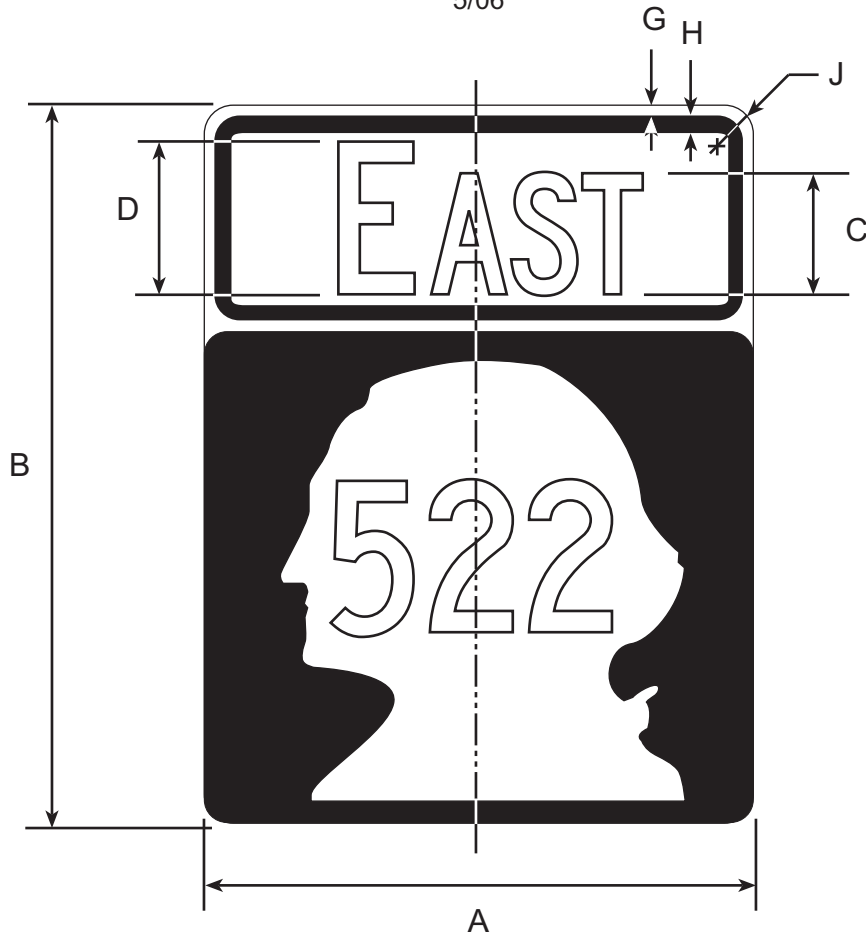

DIMENSIONS (MILLIMETERS)										
A	B	C	D	NUMBER SIZE & SERIES			SHIELD SIZE	G	H	J
				1 DIGIT	2 DIGITS	3 DIGITS				
600	900	150C	200C	325C	250C	200C	500 X 550	9	16	38
900	1200	150C	200C	450C	375C	300C	783 X 850	9	16	38

DIMENSIONS (INCHES)										
A	B	C	D	NUMBER SIZE & SERIES			SHIELD SIZE	G	H	J
				1 DIGIT	2 DIGITS	3 DIGITS				
24	36	6C	8C	13C	10C	8C	20 x 22	3/8	5/8	1 1/2
36	48	6C	8C	18C	15C	12C	31 5/16 x 34	3/8	5/8	1 1/2

COLORS

LEGEND & BACKGROUND— BLACK (NON-REFL)
SHIELD— WHITE (REFL)

M1-8

6/00

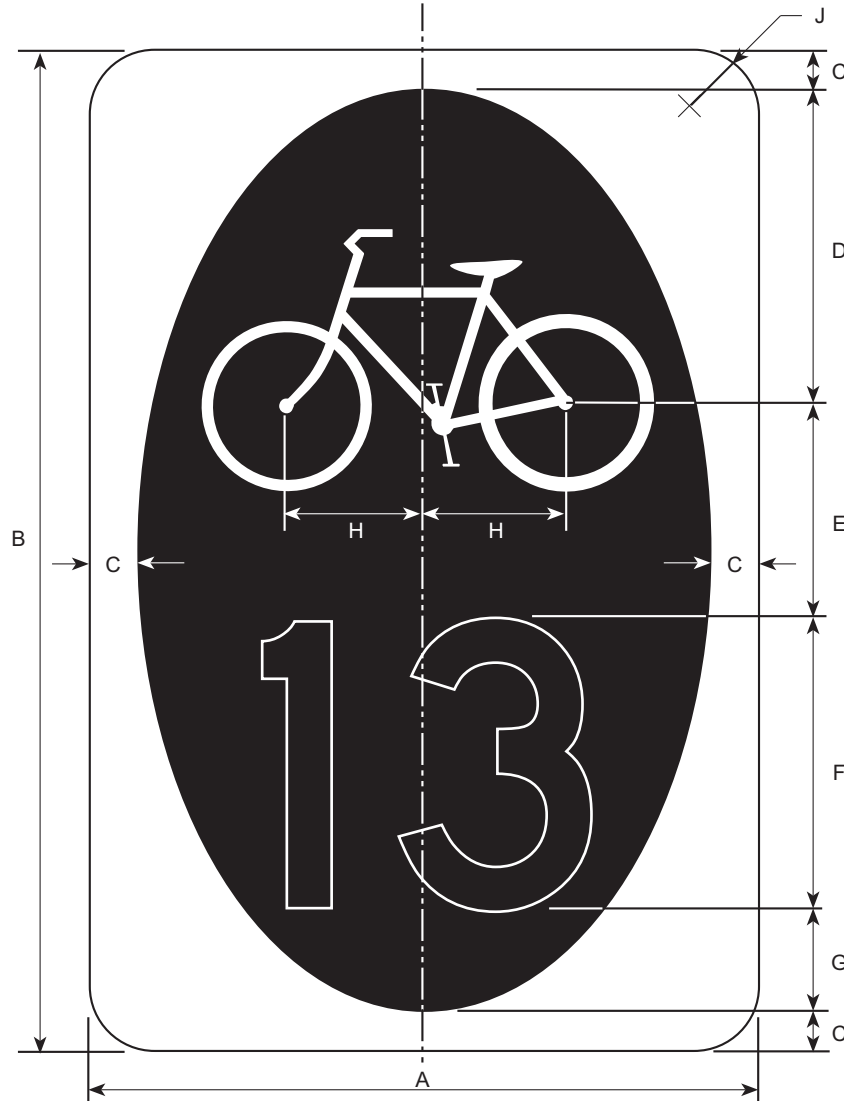

* SEE APPENDIX FOR SYMBOL DESIGN

DIMENSIONS (MILLIMETERS)								
A	B	C	D	E	F	G	H	J
300	450	25	131	100	125D	44	59	38

DIMENSIONS (INCHES)								
A	B	C	D	E	F	G	H	J
12	18	1	5 1/4	4	5D	1 3/4	2 3/8	1 1/2

COLORS

LEGEND & SYMBOL -- WHITE (REFL.)
 INNER BACKGROUND -- GREEN (REFL.)
 OUTER BACKGROUND -- WHITE (REFL.)

M4-7A

2/06

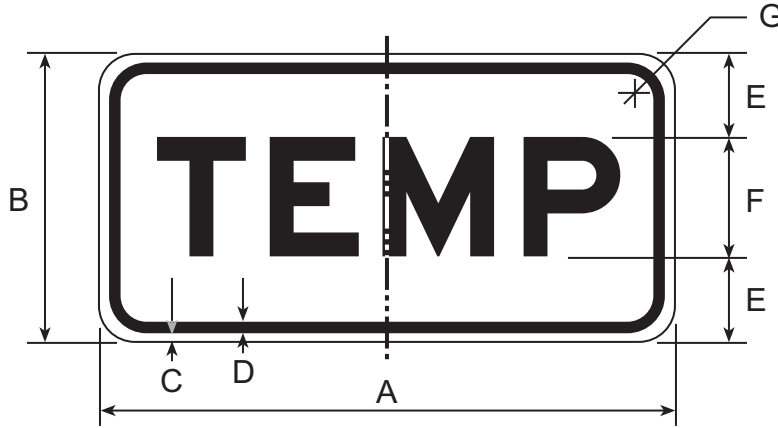

COLORS

LEGEND - BLACK (NON-REFL)
BACKGROUND - WHITE (REFL)

M4-7B

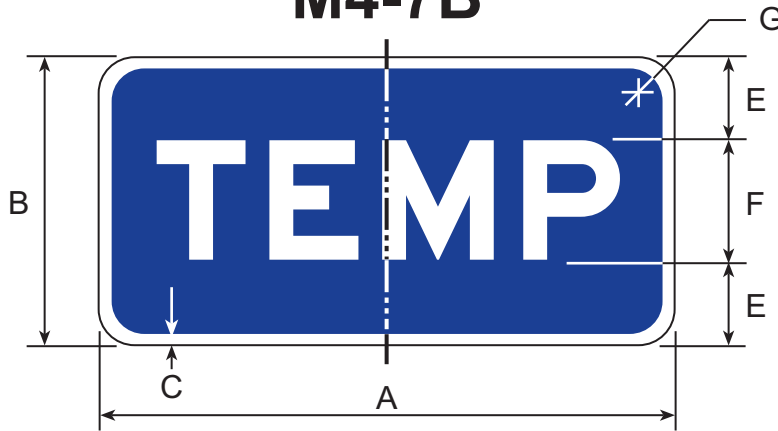

COLORS

LEGEND - WHITE (REFL)
BACKGROUND - BLUE (REFL)

DIMENSIONS (MILLIMETERS)						
A	B	C	D	E	F	G
600	300	9	16	87.5	125E	38
750	375	9	16	112.5	150E	38

DIMENSIONS (INCHES)						
A	B	C	D	E	F	G
24	12	3/8	5/8	3 1/2	5E	1 1/2
30	15	3/8	5/8	4 1/2	6E	1 1/2

M4-8

11/97



DIMENSIONS (MILLIMETERS)					
A	B	C	D	E	F
60	30	9	1	15	4
75	37	9	1	200	4

DIMENSIONS (INCHES)					
A	B	C	D	E	F
2	1	3/8	5/8	6	1
3	1	3/8	5/8	8	1

COLORS
 LEGEND — BLACK (NON-REFL)
 BACKGROUND-ORANGE (REFL)

M4-9L/R

5/06

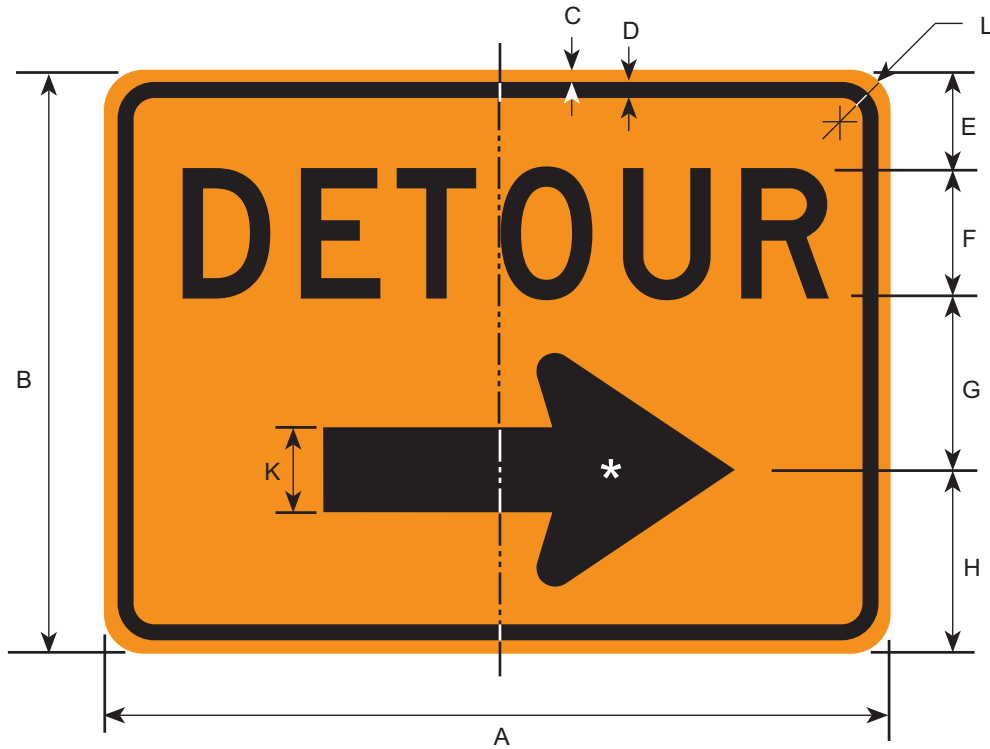

* SEE APPENDIX FOR STANDARD ARROW DETAILS

DIMENSIONS (MILLIMETERS)									
A	B	C	D	E	F	G	H	K	L
750	600	9	16	100	125D	175	200	113	38
1200	900	16	22	150	200D	250	300	175	56
1500	1200	19	31	200	250D	350	400	225	75

DIMENSIONS (INCHES)									
A	B	C	D	E	F	G	H	K	L
30	24	3/8	5/8	4	5D	7	8	4 1/2	1 1/2
48	36	5/8	7/8	6	8D	10	12	7	2 1/4
60	48	3/4	1 1/4	8	10D	14	16	9	3

COLORS

LEGEND, ARROW, & BORDER — BLACK (NON-REFL)
 BACKGROUND — ORANGE (REFL)

M4-9A

5/06

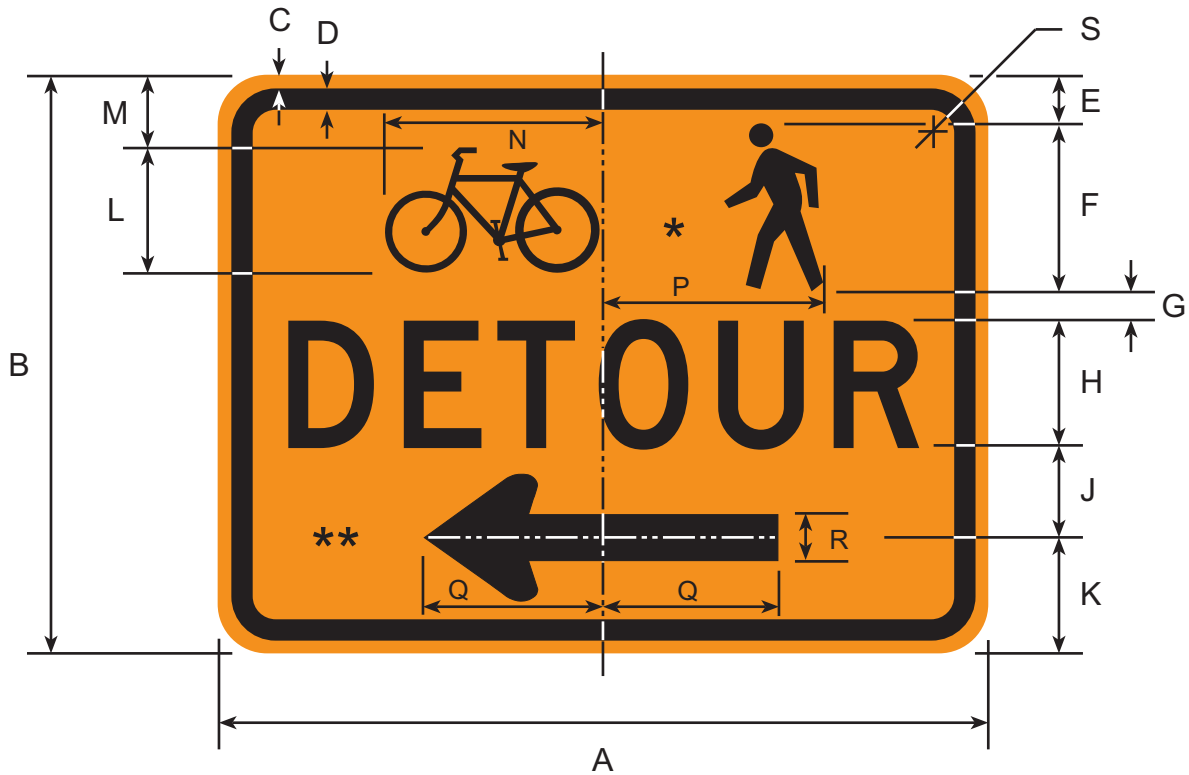

* SEE APPENDIX FOR SYMBOL DESIGNS

** SEE APPENDIX FOR STANDARD ARROW DETAILS

DIMENSIONS (INCHES)									
A	B	C	D	E	F	G	H	J	K
30	24	1/2	3/4	2	7 13/64	1	5D	3 51/64	5
48	36	3/4	1 1/4	3	10 41/64	1 41/64	8D	5 59/64	6 51/64
60	48	3/4	1 1/4	5 13/64	13 21/64	2 5/64	10D	7 13/32	10

L	M	N	P	Q	R	S
5 21/64	3 1/8	9	8 17/32	7	2	1 7/8
6 59/64	4 13/32	13 17/32	13 19/64	11 13/64	3 13/64	3
8 5/64	10 1/8	16 13/16	16 13/16	14	4	3

COLORS

LEGEND, SYMBOLS, & BORDER - BLACK (NON-REFL)
BACKGROUND - ORANGE (REFL)

M4-9B

5/06

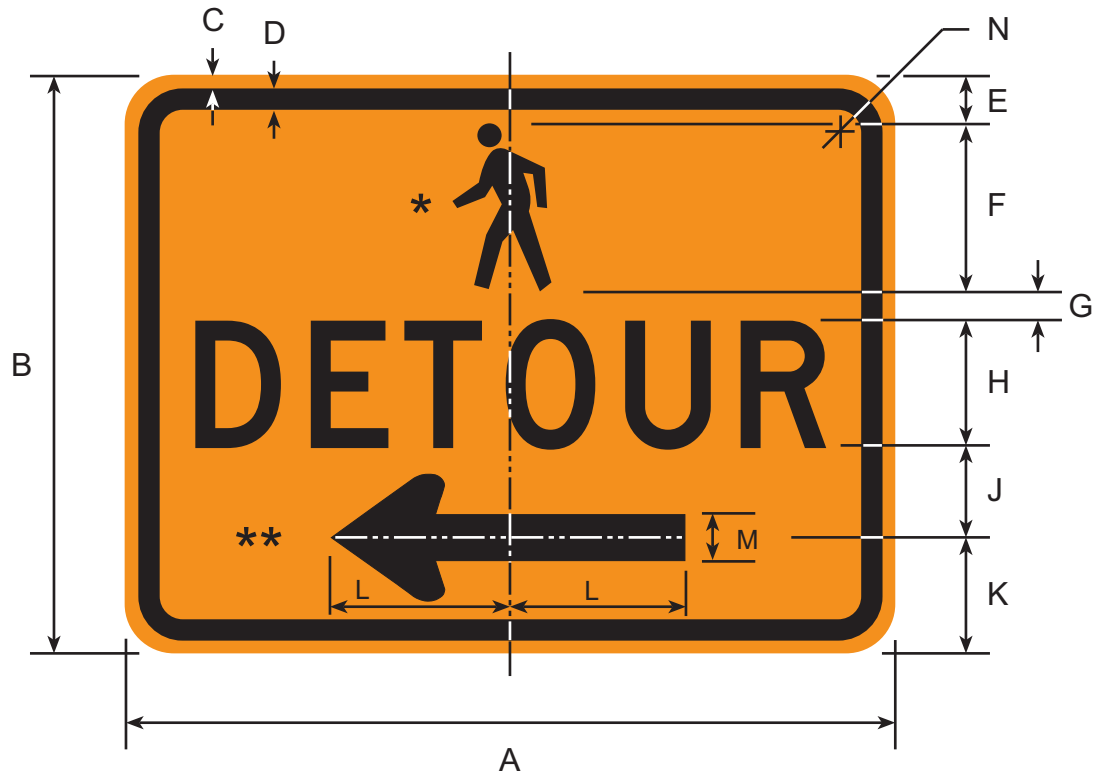

* SEE APPENDIX FOR SYMBOL DESIGN

** SEE APPENDIX FOR STANDARD ARROW DETAILS

DIMENSIONS (INCHES)						
A	B	C	D	E	F	G
30	24	1/2	3/4	2	7 13/64	1
48	36	3/4	1 1/4	3	10 41/64	1 41/64
60	48	3/4	1 1/4	5 13/64	13 21/64	2 5/64

H	J	K	L	M	N
5D	3 51/64	5	7	2	1 7/8
8D	5 59/64	6 51/64	11 13/64	3 13/64	3
10D	7 13/32	10	14	4	3

COLORS

LEGEND, SYMBOLS, & BORDER - BLACK (NON-REFL)
BACKGROUND - ORANGE (REFL)

M4-9C

5/06

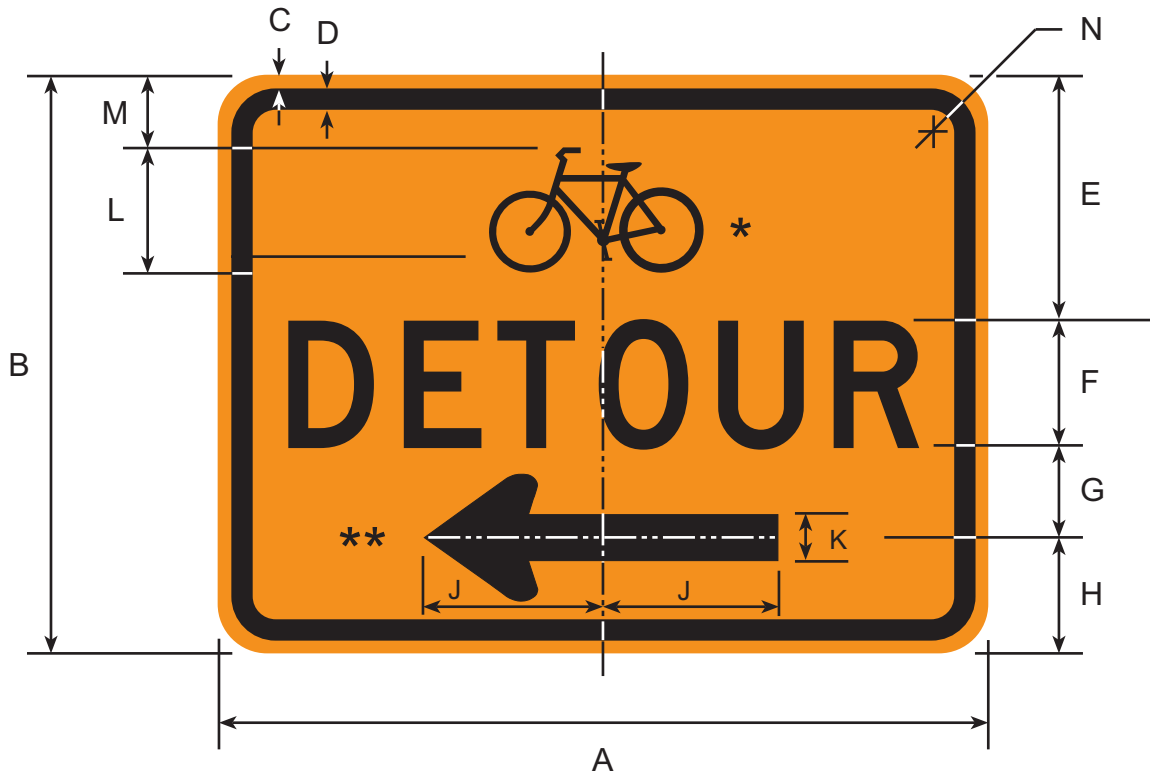

* SEE APPENDIX FOR SYMBOL DESIGN

** SEE APPENDIX FOR STANDARD ARROW DETAILS

DIMENSIONS (INCHES)						
A	B	C	D	E	F	G
30	24	1/2	3/4	10 13/64	5D	3 51/64
48	36	3/4	1 1/4	15 19/64	8D	5 59/64
60	48	3/4	1 1/4	20 39/64	10D	7 13/32

H	J	K	L	M	N
5	7	2	5 21/64	9	1 7/8
6 51/64	11 13/64	3 13/64	6 59/64	13 17/32	3
10	14	4	8 5/64	16 13/16	3

COLORS

LEGEND, SYMBOLS, & BORDER - BLACK (NON-REFL)
 BACKGROUND - ORANGE (REFL)

M4-10L & M4-10R

11/97

M4-10L

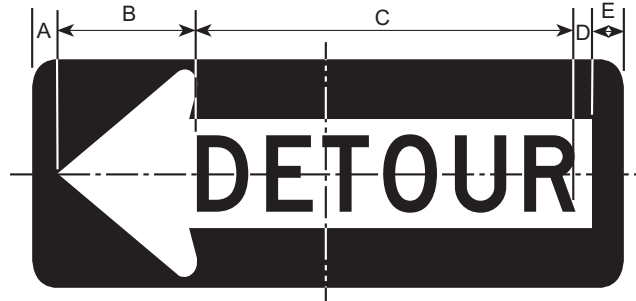

DIMENSIONS (MILLIMETERS)				
A	B	C	D	E
69	313	694	50	75

DIMENSIONS (INCHES)				
A	B	C	D	E
2 3/4	12 1/2	27 3/4	2	3

M4-10R

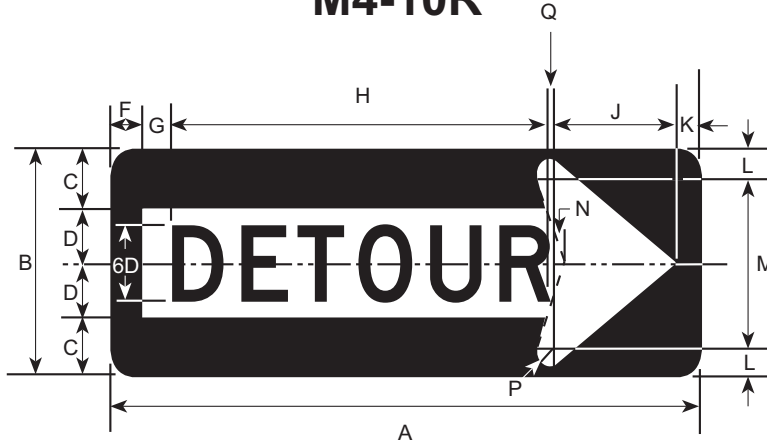

DIMENSIONS (MILLIMETERS)														
A	B	C	D	E	F	G	H	J	K	L	M	N	P	Q
1200	450	122	103	150D	75	50	694	300	69	56	338	19	31	13

DIMENSIONS (INCHES)														
A	B	C	D	E	F	G	H	J	K	L	M	N	P	Q
48	18	4 7/8	4 1/8	6D	3	2	27 3/4	12	2 3/4	2 1/4	13 1/2	3/4	1 1/4	1/2

COLORS

- LEGEND - BLACK (NON-REFL.)
- ARROW - ORANGE (REFL.)
- BACKGROUND - BLACK (NON - REFL.)

M5-1

5/06

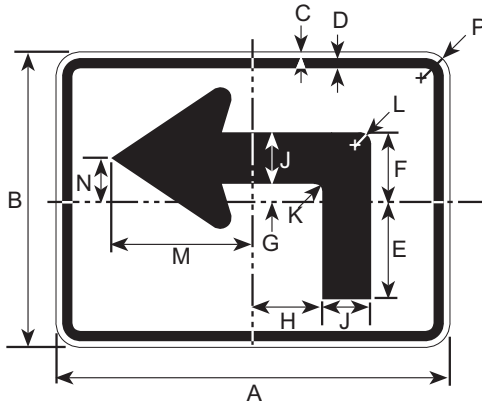

M5-1B

5/06

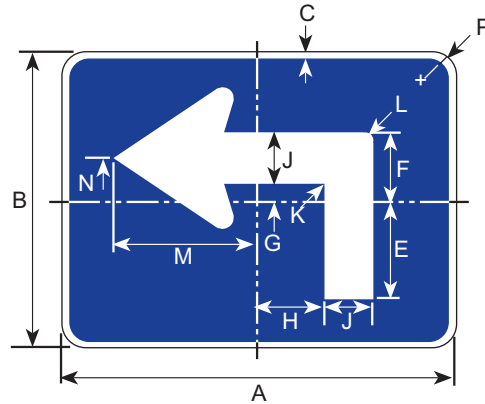

DIMENSIONS (MILLIMETERS)

A	B	C	D	E	F	G	H	J	K	L	M	N	P
525	375	9	16	127	84	22	80	66	9	14	178	52	38

DIMENSIONS (INCHES)

A	B	C	D	E	F	G	H	J	K	L	M	N	P
21	15	3/8	5/8	5 1/16	3 3/8	3/4	3 3/16	2 5/8	3/8	9/16	7 1/8	2 1/16	1 1/2

M5-2

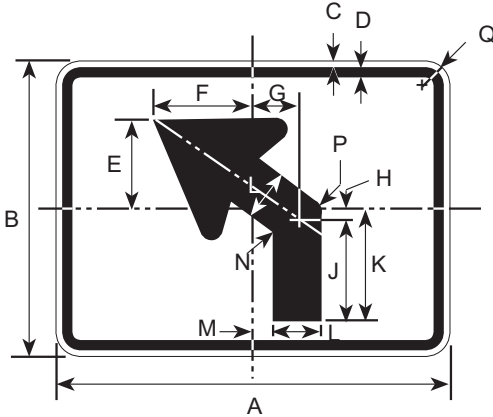

M5-2B

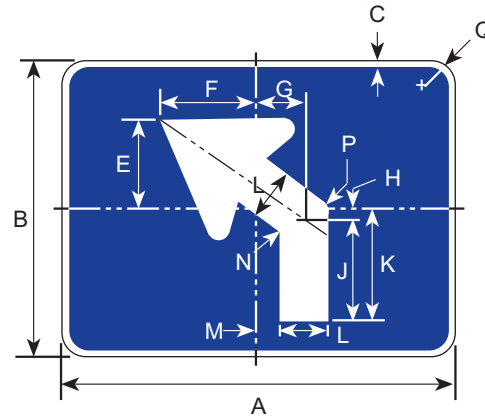

DIMENSIONS (MILLIMETERS)

A	B	C	E	F	G	H	J	K	L	M	N	P	Q
525	375	9	119	113	61	19	117	136	66	28	9	14	38

DIMENSIONS (INCHES)

A	B	C	D	E	F	G	H	J	K	L	M	N	P	Q
21	15	3/8	5/8	4 3/4	4 1/2	2 7/16	3/4	4 11/16	5 7/16	2 5/8	1 1/8	3/8	9/16	1 1/2

COLORS

ARROW & BORDER - BLACK (NON-REFL)
BACKGROUND - WHITE (REFL)

COLORS

ARROW - WHITE (REFL)
BACKGROUND - BLUE (REFL)

M6-1

6/00

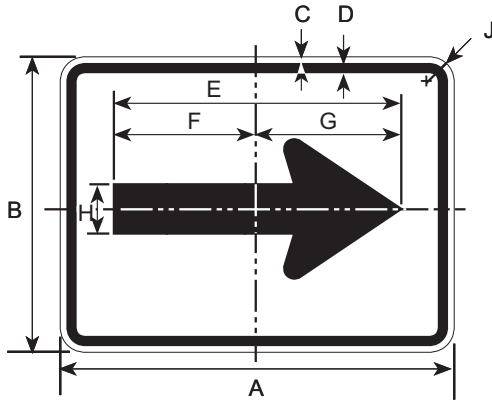

M6-1B

6/00

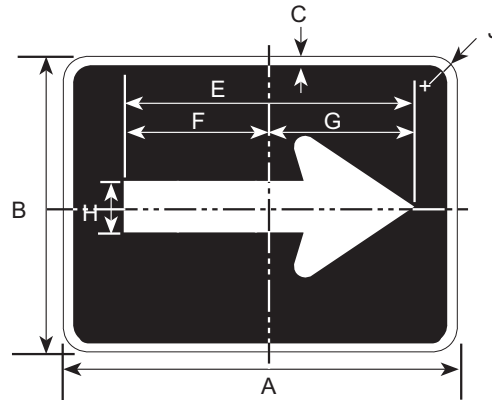

DIMENSIONS (MILLIMETERS)								
A	B	C	D	E	F	G	H	J
525	375	9	16	52	178	188	66	38

DIMENSIONS (INCHES)								
A	B	C	D	E	F	G	H	J
21	15	3/8	5/8	14 5/8	7 1/8	7 1/2	2 5/8	1 1/2

M6-2R

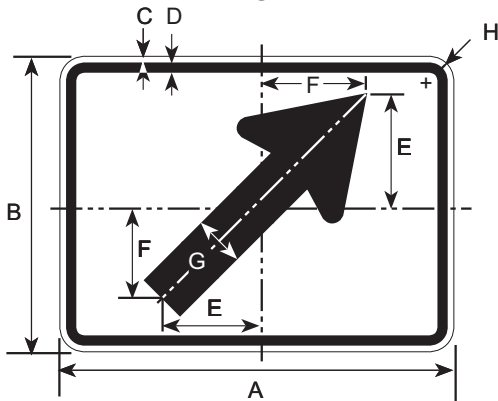

M6-2BR

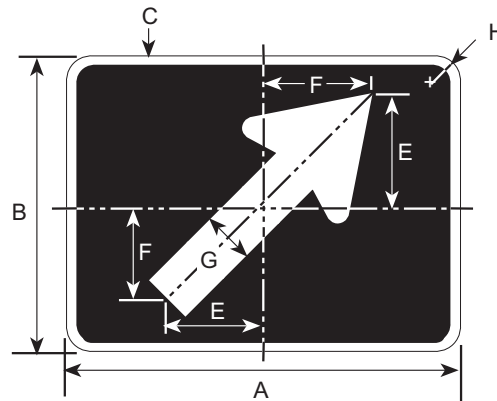

M6-2L



DIMENSIONS (MILLIMETERS)							
A	B	C	D	E	F	G	H
525	375	9	16	127	141	66	38

DIMENSIONS (INCHES)							
A	B	C	D	E	F	G	H
21	15	3/8	5/8	5 1/16	5 5/8	2 5/8	1 1/2

M6-2BL



COLORS

LEGEND - BLACK (NON-REFL.)
BACKGROUND - WHITE (REFL.)

COLORS

LEGEND - WHITE (REFL.)
BACKGROUND - BLUE (REFL.)

M8-101

5/06

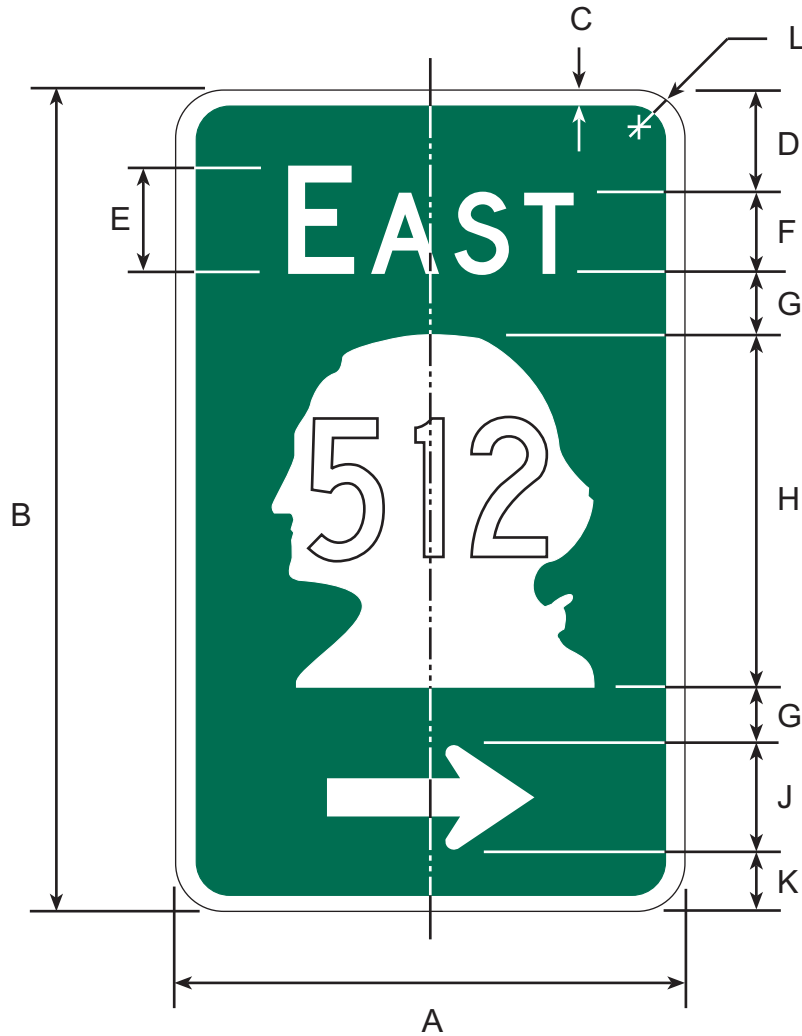

NUMERALS ON STATE AND FEDERAL SHIELDS SHALL BE BLACK.
FOR NUMERALS SIZE AND SERIES SEE APPLICABLE ROUTE MARKER.

DIMENSIONS (MILLIMETERS)										
A	B	C	D	E	F	G	H	J	K	L
900	1500	19	200	200D	150D	94	550	213 x 250	150	100

DIMENSIONS (INCHES)										
A	B	C	D	E	F	G	H	J	K	L
36	60	3/4	8	8D	6D	3 3/4	22	8 1/2 x 10	6	4

COLORS

LEGEND - WHITE (REFL)
BACKGROUND - GREEN (REFL)

M8-201

2/06



* SEE APPENDIX FOR STANDARD ARROW DETAIL

DIMENSIONS (MILLIMETERS)							
A	B	C	D	E	F	ARROW	SHIELD
2100	900	19	150D	200D	100	#1	600

DIMENSIONS (INCHES)							
A	B	C	D	E	F	ARROW	SHIELD
84	36	3/4	6D	8D	4	#1	24

COLORS

LEGEND— WHITE (REFL)
BACKGROUND— GREEN (REFL)

R1-5L

2/06

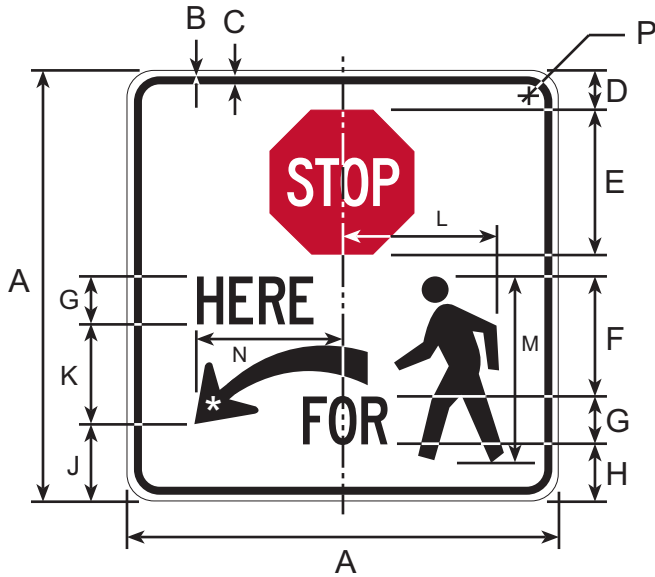

R1-5R



DIMENSIONS (MILLIMETERS)													
A	B	C	D	E	F	G	H	J	K	L	M	N	P
450	9	16	41	144	125	50C	60	75	109	165	193	165	38
750	13	19	69	256	213	75C	106	125	181	275	325	275	47
900	16	22	81	319	250	100C	119	150	219	331	391	331	56

DIMENSIONS (INCHES)													
A	B	C	D	E	F	G	H	J	K	L	M	N	P
18	3/8	5/8	1 5/8	5 3/4	5	2C	2 3/8	3	4 3/8	6 5/8	7 3/4	6 5/8	1 1/2
30	1/2	3/4	2 3/4	10 1/4	8 1/2	3C	4 1/4	5	7 1/4	11	13	11	1 7/8
36	5/8	7/8	3 1/4	12 3/4	10	4C	4 3/4	6	8 3/4	13 1/4	15 5/8	13 1/4	2 1/4

* See R10-6A for arrow details

COLORS

- SIGN LEGEND, ARROW, & PEDESTRIAN SYMBOL - BLACK (NON-REFL)
- BACKGROUND - WHITE (REFL)
- STOP SYMBOL - RED (REFL)
- STOP LEGEND - WHITE (REFL)

R1-6A

2/06

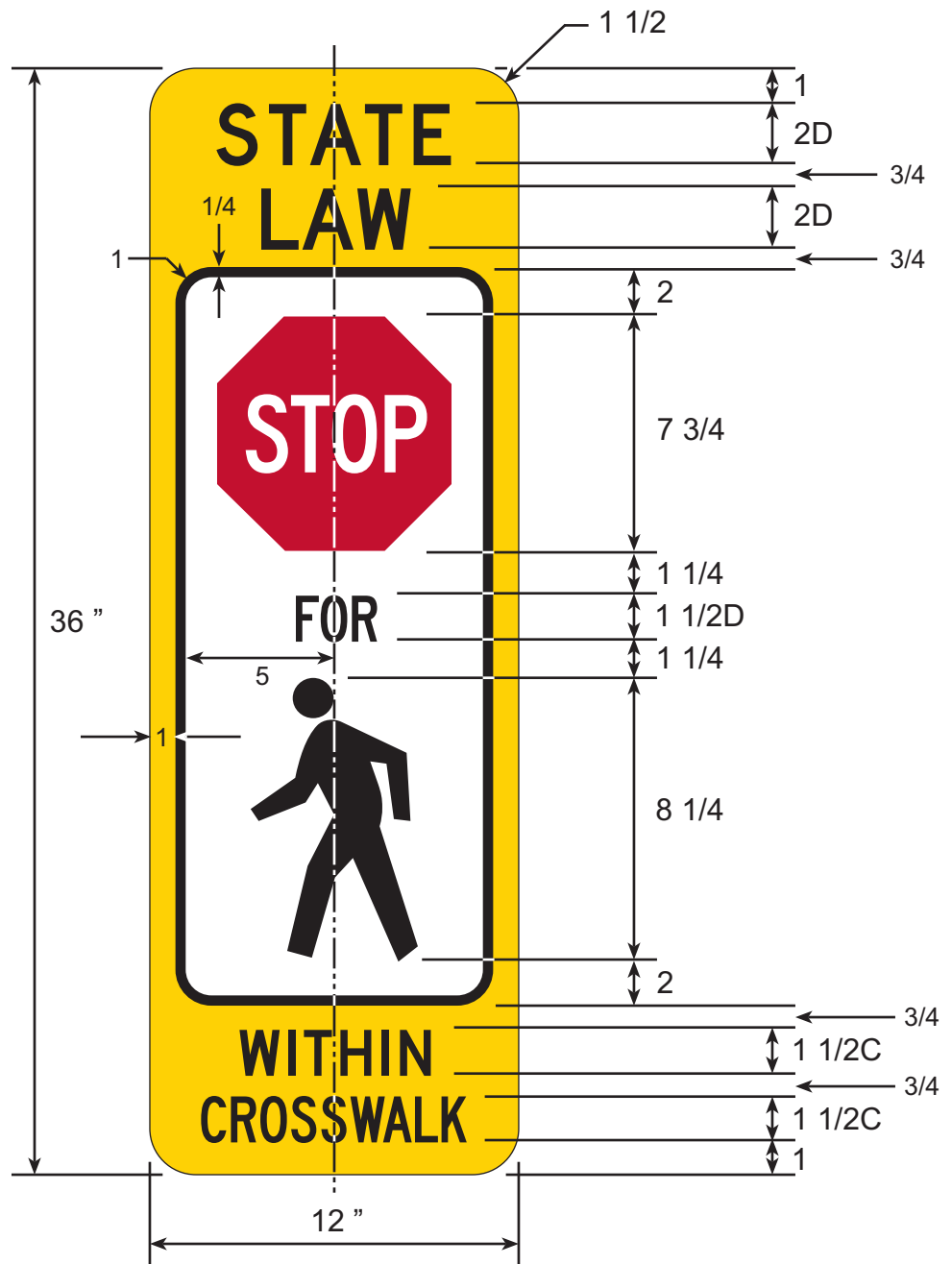

COLORS

- LEGEND - BLACK (NON-REFL)
- BACKGROUND - YELLOW OR FLOURESCENT YELLOW-GREEN (REFL)
- PED SYMBOL - BLACK (NON-REFL) ON WHITE (REFL)
- STOP SYMBOL - RED (REFL)
- STOP LEGEND - WHITE (REFL)

R2-4A

6/00

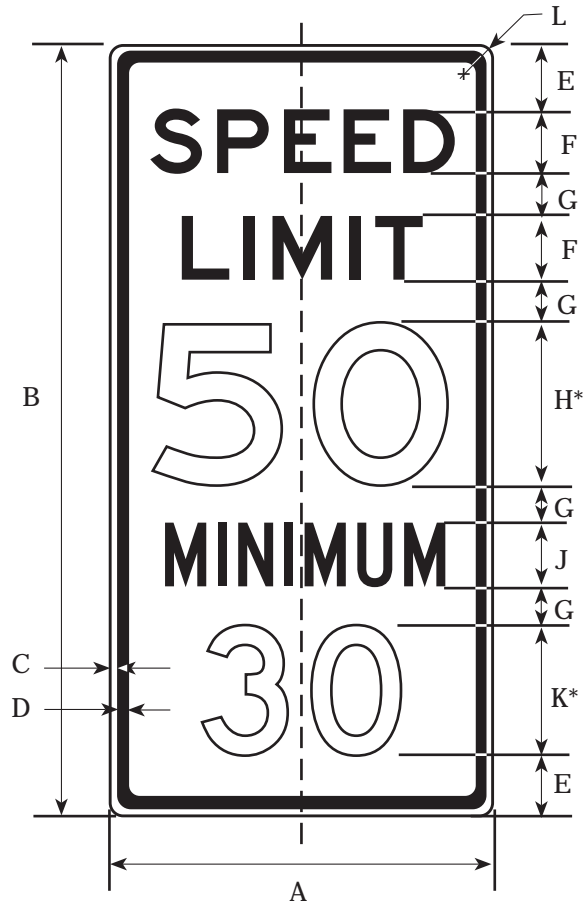

DIMENSIONS (MILLIMETERS)										
A	B	C	D	E	F	G	H	J	K	L
600	1200	9	16	100	100E	63	250E	100C	200D	38
900	1800	16	22	150	150E	100	350E	150C	300D	56
1200	2400	19	31	200	200E	162.5	400E	200C	350D	75

DIMENSIONS (INCHES)										
A	B	C	D	E	F	G	H	J	K	L
24	48	3/8	5/8	4	4E	2 1/2	10E	4C	8D	1 1/2
36	72	5/8	7/8	6	6E	4	14E	6C	12D	2 1/4
48	96	3/4	1 1/4	8	8E	6 1/2	16E	8C	14D	3

* Optically space numerals about vertical centerline.

COLORS

LEGEND - BLACK (NON-REFL)
BACKGROUND - WHITE (REFL)

R2-501

6/00

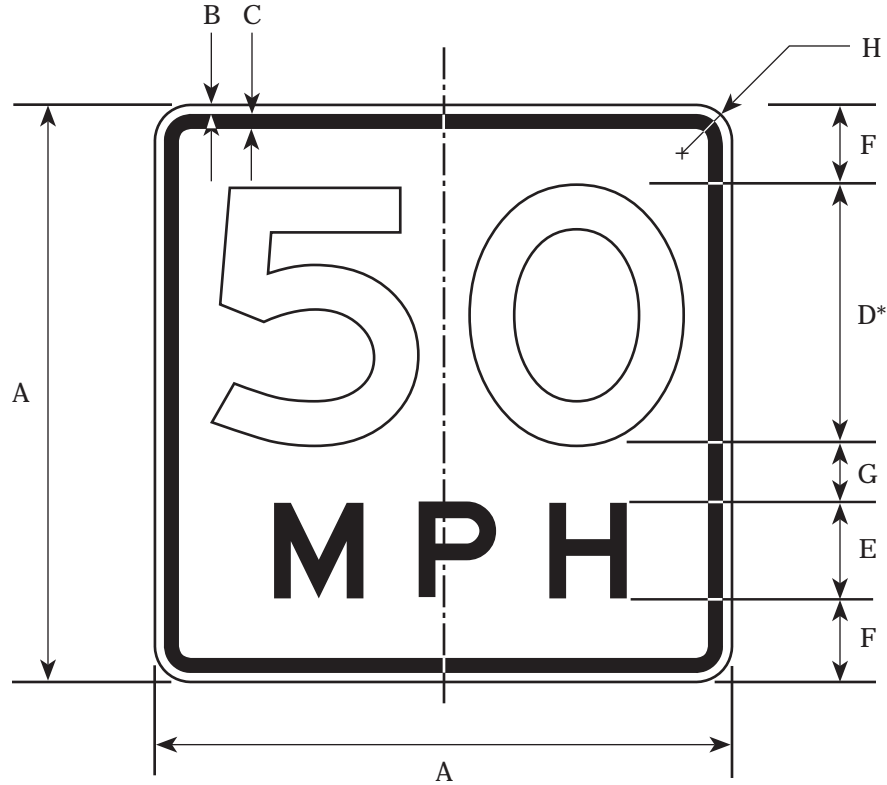

DIMENSIONS (MILLIMETERS)							
A	B	C	D	E	F	G	H
450	9	9	200E	75E	66	43	38
600	9	16	250E	100E	100	50	38
750	13	19	300E	125E	119	87	47
900	19	22	375E	150E	13	100	56
1200	19	28	450E	175E	200	75	72

DIMENSIONS (INCHES)							
A	B	C	D	E	F	G	H
18	3/8	3/8	8E	3E	2 5/8	1 3/4	1 1/2
24	3/8	5/8	10E	4E	4	2	1 1/2
30	1/2	3/4	12E	5E	4 3/4	3 1/2	1 7/8
36	3/4	7/8	15E	6E	5 1/2	4	2 1/4
48	3/4	1 1/4	18E	7E	8	7	2 7/8

COLORS

LEGEND - BLACK (NON-REFL)
BACKGROUND - WHITE (REFL)

* Optically space numerals
about vertical centerline

R3-1102R

3/06

R3-1102L

3/06

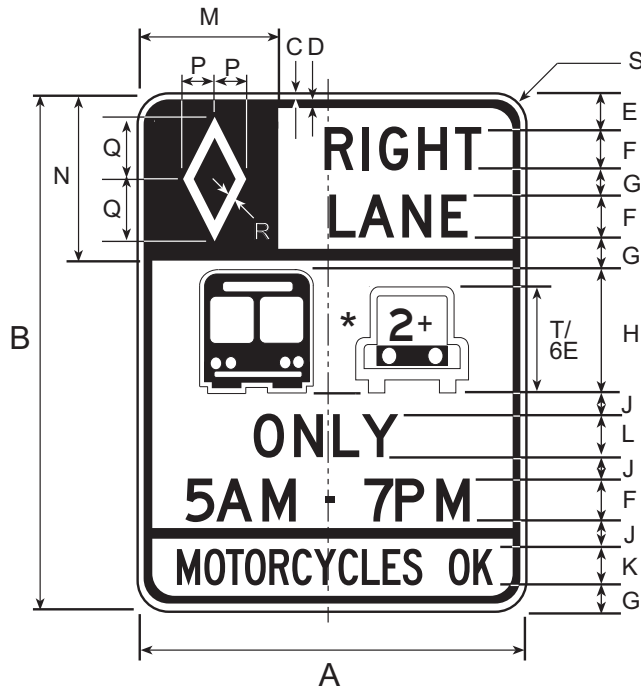

* SEE APPENDIX FOR STANDARD SYMBOLS

DIMENSIONS (MILLIMETERS)								
A	B	C	D	E	F	G	H	J
1350	1800	19	31	150	150D	100	450	75
K	L	M	N	P	Q	R	S	T
75C	150E	55	650	125	250	38	38	300

DIMENSIONS (INCHES)								
A	B	C	D	E	F	G	H	J
54	72	3/4	1 1/4	6	6D	4	18	3
K	L	M	N	P	Q	R	S	T
3C	6E	22	26	5	10	1 1/2	3	12

COLORS

LEGEND - BLACK (NON-REFL)
 BACKGROUND - WHITE (REFL)
 PREFERENTIAL LANE SYMBOL - WHITE (REFL) ON BLACK (NON-REFL)

R3-1103R

3/06

R3-1103L

3/06

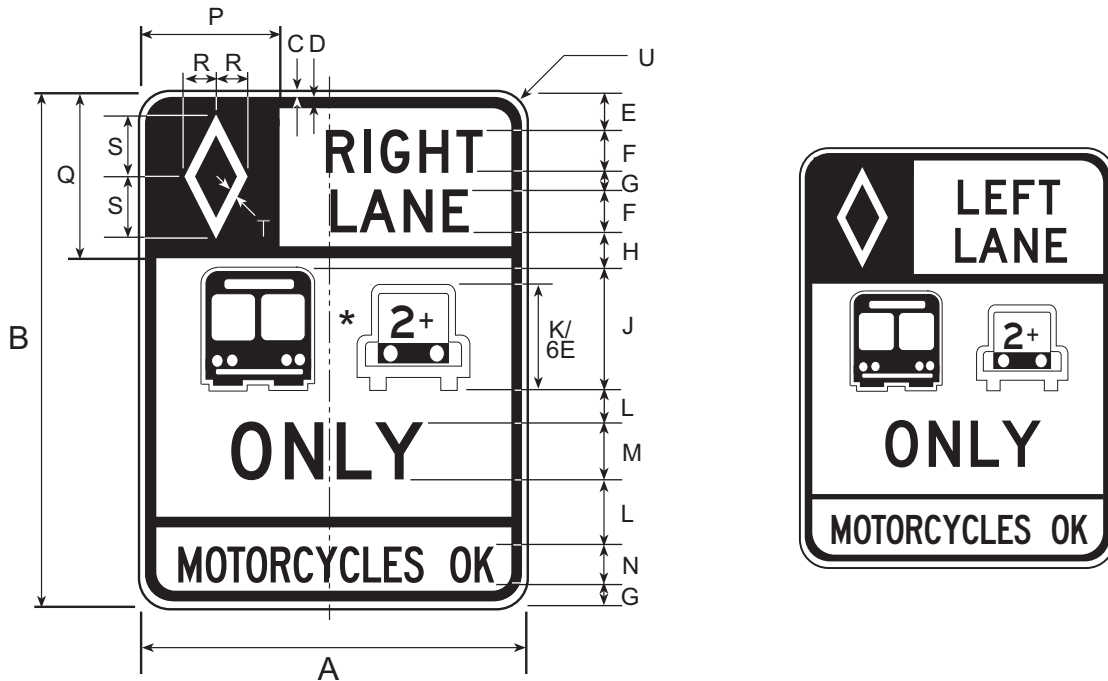

* SEE APPENDIX FOR STANDARD SYMBOLS

DIMENSIONS (MILLIMETERS)									
A	B	C	D	E	F	G	H	J	K
1350	1800	19	31	150	150D	100	125	450	300

L	M	N	P	Q	R	S	T	U
150	200D	75C	550	650	125	250	38	75

DIMENSIONS (INCHES)									
A	B	C	D	E	F	G	H	J	K
54	72	3/4	1 1/4	6	6D	4	5	18	12

L	M	N	P	Q	R	S	T	U
6	8D	3C	22	26	5	10	1 1/2	3

COLORS

LEGEND - BLACK (NON-REFL)
 BACKGROUND - WHITE (REFL)
 SYMBOLS - WHITE (REFL) ON BLACK (NON-REFL)

R3-1104L

6/03

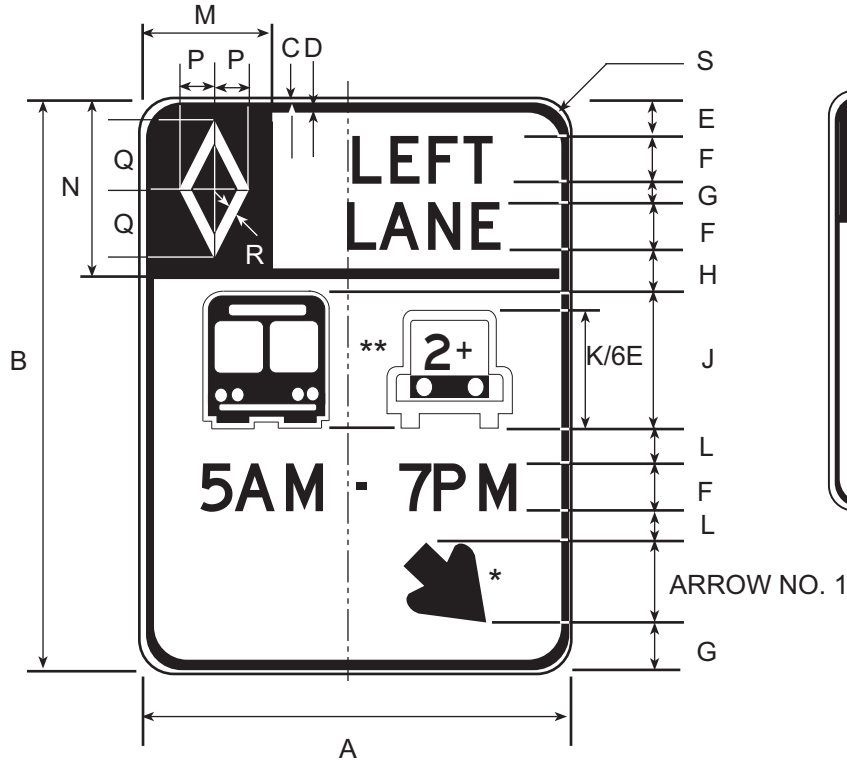

R3-1104R

6/03



* SEE APPENDIX FOR STANDARD ARROW DETAILS

** SEE APPENDIX FOR STANDARD SYMBOLS

DIMENSIONS (MILLIMETERS)								
A	B	C	D	E	F	G	H	J
1350	1800	19	31	150	150D	100	125	450

K	L	M	N	P	Q	R	S
300	75	550	650	125	200	38	75

DIMENSIONS (MILLIMETERS)								
A	B	C	D	E	F	G	H	J
54	72	3/4	1 1/4	6	6D	4	5	18

K	L	M	N	P	Q	R	S
12	3	22	26	5	10	1 1/2	3

COLORS

LEGEND - BLACK (NON-REFL)

BACKGROUND - WHITE (REFL)

SYMBOLS - WHITE (REFL) ON BLACK (NON-REFL)

R3-14

11/97

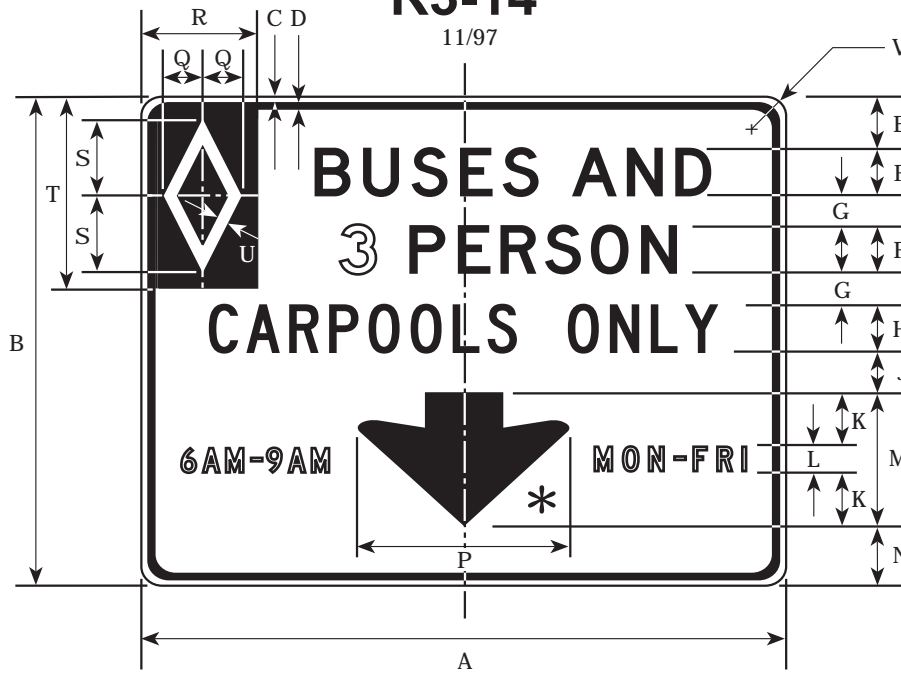

* See appendix for standard arrow details

DIMENSIONS (MILLIMETERS)									
A	B	C	D	E	F	G	H	J	K
1800	1500	25	38	150	150D	100	150C	113	169
2400	1800	31	44	200	200D	150	200C	113	156
2700	2100	38	50	250	250D	150	250C	100	213
L	M	N	P	Q	R	S	T	U	V
75C	413	175	600	100	275	200	550	31	94
100C	413	175	600	125	375	250	750	38	125
125C	550	150	800	150	450	300	900	50	150

DIMENSIONS (INCHES)									
A	B	C	D	E	F	G	H	J	K
72	60	1	1 1/2	6	6D	4	6C	4 1/2	6 3/4
96	72	1 1/4	1 3/4	8	8D	6	8C	4 1/2	6 1/4
108	84	1 1/2	2	10	10D	6	10C	4	8 1/2
L	M	N	P	Q	R	S	T	U	V
3C	16 1/2	7	24	4	11	8	22	1 1/4	3 3/4
4C	16 1/2	7	24	5	15	10	30	1 1/2	5
5C	22	6	32	6	18	12	36	2	6

COLORS

LEGEND - BLACK (NON REFL)
 BACKGROUND - WHITE (REFL)
 SYMBOL - REFL WHITE ON BLACK

R3-1401

3/06

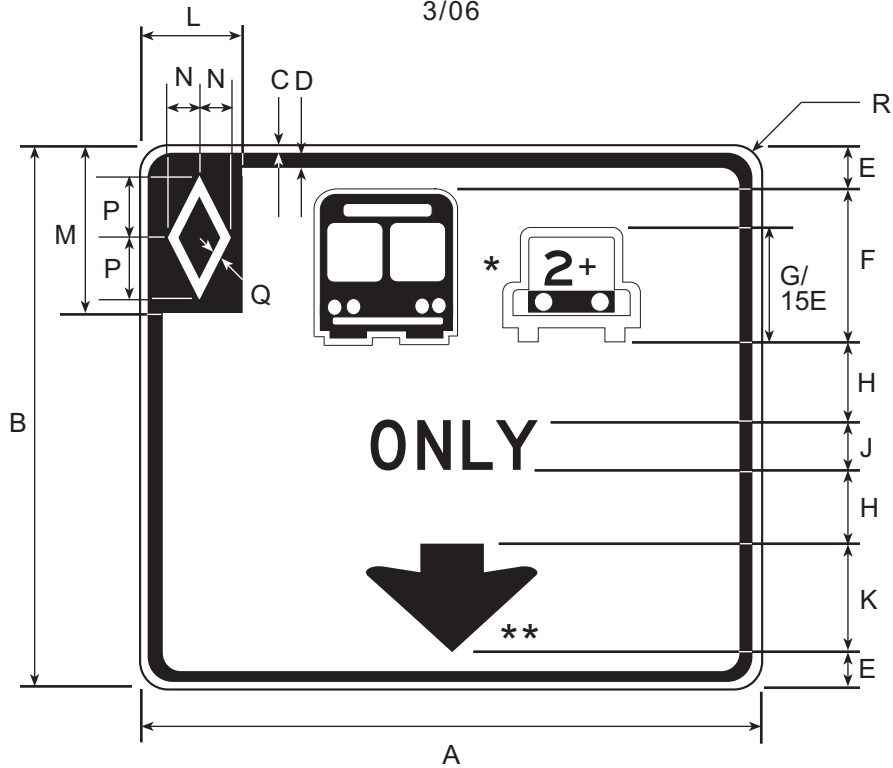

* SEE APPENDIX FOR STANDARD SYMBOLS

** SEE APPENDIX FOR STANDARD ARROW DETAILS

DIMENSIONS (MILLIMETERS)							
A	B	C	D	E	F	G	H
3000	2900	38	50	150	900	750	200
J	K	L	M	N	P	Q	R
250D	550	450	900	150	300	50	150

DIMENSIONS (INCHES)							
A	B	C	D	E	F	G	H
120	96	1 1/2	2	6	36	30	8
J	K	L	M	N	P	Q	R
10D	22	18	36	6	12	2	6

COLORS

LEGEND - BLACK (NON-REFL)
 BACKGROUND - WHITE (REFL)
 SYMBOLS - WHITE (REFL) ON BLACK (NON-REFL)

R3-17

2/06

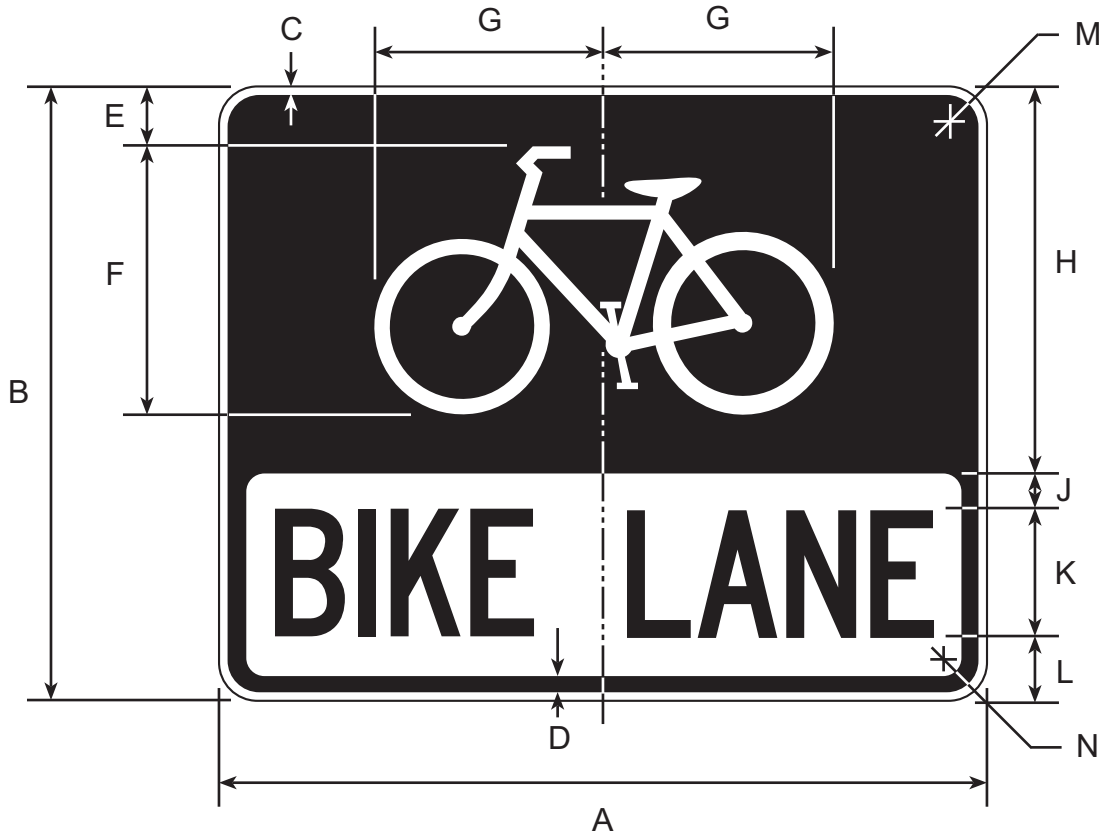

****** See appendix for standard symbol details

DIMENSIONS (MILLIMETERS)												
A	B	C	D	E	F	G	H	J	K	L	M	N
750	600	9	16	69	262	225	375	38	125C	63	38	19

DIMENSIONS (INCHES)												
A	B	C	D	E	F	G	H	J	K	L	M	N
30	24	3/8	5/8	2 3/4	10 1/2	9	15	1 1/2	5C	2 1/2	1 1/2	3/4

COLORS

TOP

SYMBOL - WHITE (REFL)
BACKGROUND - BLACK (NON-REFL)

BOTTOM

LEGEND - BLACK (NON-REFL)
BACKGROUND - WHITE (REFL)

R3-17B

2/06



R3-17C



DIMENSIONS (MILLIMETERS)						
A	B	C	D	E	F	G
750	300	9	16	88	125D	38

DIMENSIONS (INCHES)						
A	B	C	D	E	F	G
30	12	3/8	5/8	3 1/2	5D	1 1/2

COLORS

LEGEND - BLACK (NON-REFL)
BACKGROUND - WHITE (REFL)

R3-18

2/06

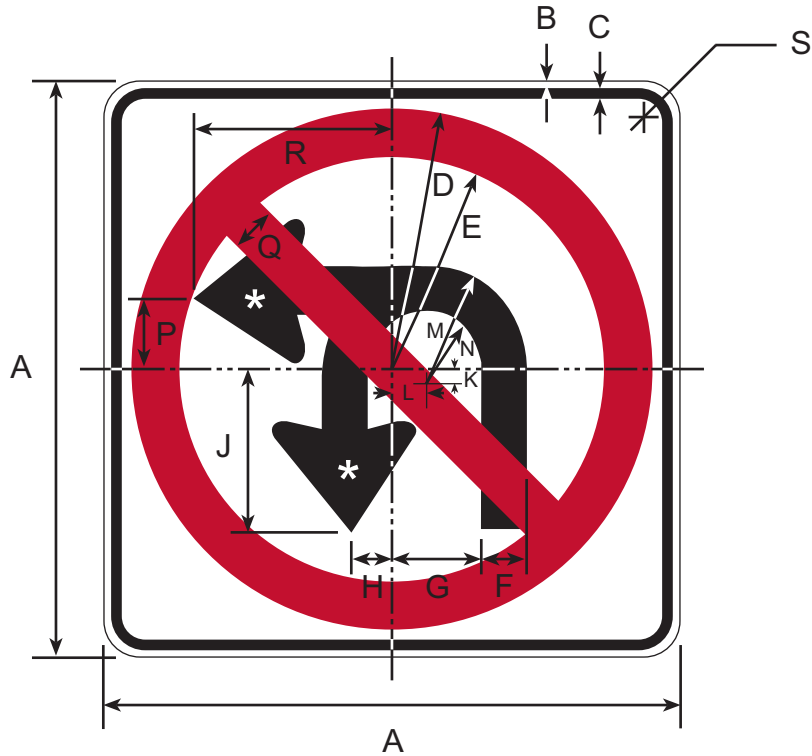

* SEE APPENDIX FOR STANDARD ARROW DETAILS

DIMENSIONS IN INCHES

A	B	C	D	E	F	G	H
24	3/8	5/8	10 13/32	8 9/16	2 5/64	3 11/16	1 27/32
30	1/2	3/4	13	10 3/4	2 19/32	4 19/32	2 9/32
36	5/8	7/8	15 39/64	12 57/64	3 1/8	5 33/64	2 3/4
48	3/4	1 1/4	20 13/16	17 9/64	4 11/64	7 3/8	3 11/16

J	K	L	M	N	P	Q	R	S
6 51/64	13/32	1 1/2	4 21/64	2 1/4	2 59/64	1 39/64	8 3/32	1 1/2
8 17/32	31/64	1 51/64	5 13/32	2 51/64	3 21/32	2	10 3/32	1 7/8
10 1/4	9/16	2 11/64	6 31/64	3 3/8	4 3/8	2 13/32	12 3/32	2 1/4
13 39/64	51/64	2 7/8	8 41/64	4 31/64	5 27/32	3 13/64	16 11/64	3

COLORS

CIRCLE & DIAGONAL - RED (REFL)
 ARROWS & BORDER - BLACK (NON-REFL)
 BACKGROUND - WHITE (REFL)

R4-7

3/06

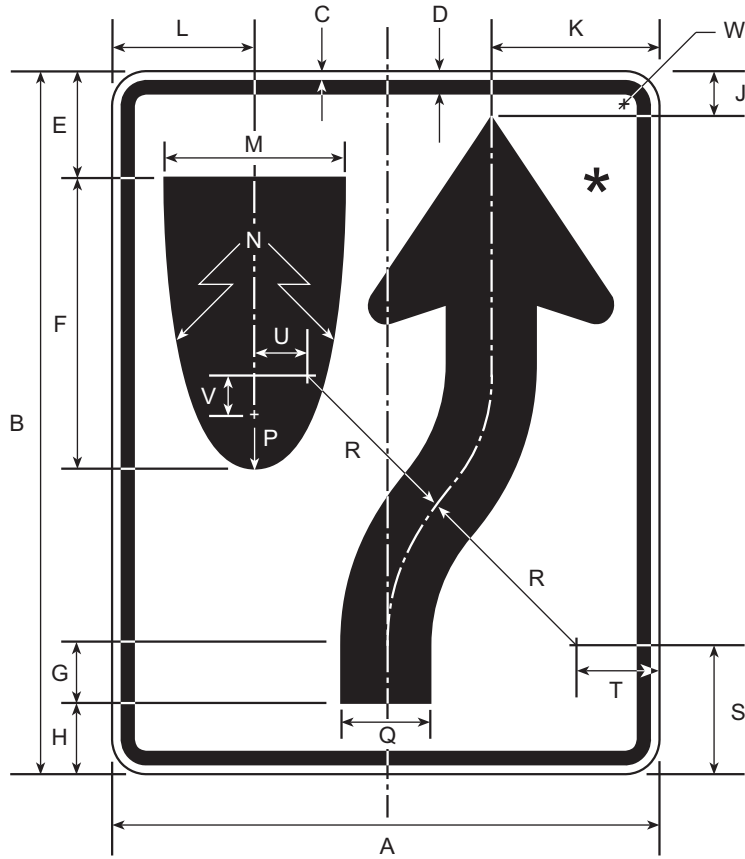

* SEE APPENDIX FOR STANDARD ARROW DETAILS

DIMENSIONS (MILLIMETERS)																				
A	B	C	D	E	F	G	H	J	K	L	M	N	P	Q	R	S	T	U	V	W
450	600	9	16	84	234	47	56	34	138	117	150	563	38	75	169	103	56	27	11	38
600	750	9	16	113	313	63	75	47	184	156	200	750	50	100	225	138	75	34	70	38
900	1200	16	22	169	469	94	113	70	278	234	300	1125	75	150	338	206	113	50	69	56
1200	1500	19	50	225	625	125	150	94	370	313	400	2700	100	200	450	275	150	67	125	75

DIMENSIONS (INCHES)																				
A	B	C	D	E	F	G	H	J	K	L	M	N	P	Q	R	S	T	U	V	W
18	24	3/8	5/8	3 3/8	9 3/8	1 7/8	2 1/4	1 3/8	5 1/2	4 11/16	6	22 1/2	1 1/2	3	6 3/4	4 1/8	2 1/4	1 1/16	7/16	1 1/2
24	30	3/8	5/8	4 1/2	12 1/2	2 1/2	3	1 7/8	7 3/8	6 1/4	8	30	2	4	9	5 1/2	3	1 3/8	2 13/16	1 1/2
36	48	5/8	7/8	6 3/4	18 3/4	3 3/4	4 1/2	2 13/16	11 1/8	9 3/8	12	45	3	6	13 1/2	8 1/4	4 1/2	2	2 3/4	2 1/4
48	60	3/4	1 1/4	9	25	5	6	3 3/4	14 13/16	12 1/2	16	60	4	8	18	11	6	2 11/16	5	3

COLORS

LEGEND — BLACK (NON-REFL)
BACKGROUND — WHITE (REFL)

R4-901

11/97



DIMENSIONS (MILLIMETERS)								
A	B	C	D	E	F	G	H	J
600	750	9	16	78	125E	56	100D	38
900	1200	16	22	138	175E	100	150D	56
1200	1500	19	31	169	225E	113	200D	75

DIMENSIONS (INCHES)								
A	B	C	D	E	F	G	H	J
24	30	3/8	5/8	3 1/8	5E	2 1/4	4D	1 1/2
36	48	5/8	7/8	5 1/2	7E	4	6D	2 1/4
48	60	3/4	1 1/4	6 3/4	9E	4 1/2	8D	3

COLORS

LEGEND — BLACK (NON-REFL)
 BACKGROUND — WHITE (REFL)

R4-10

3/06

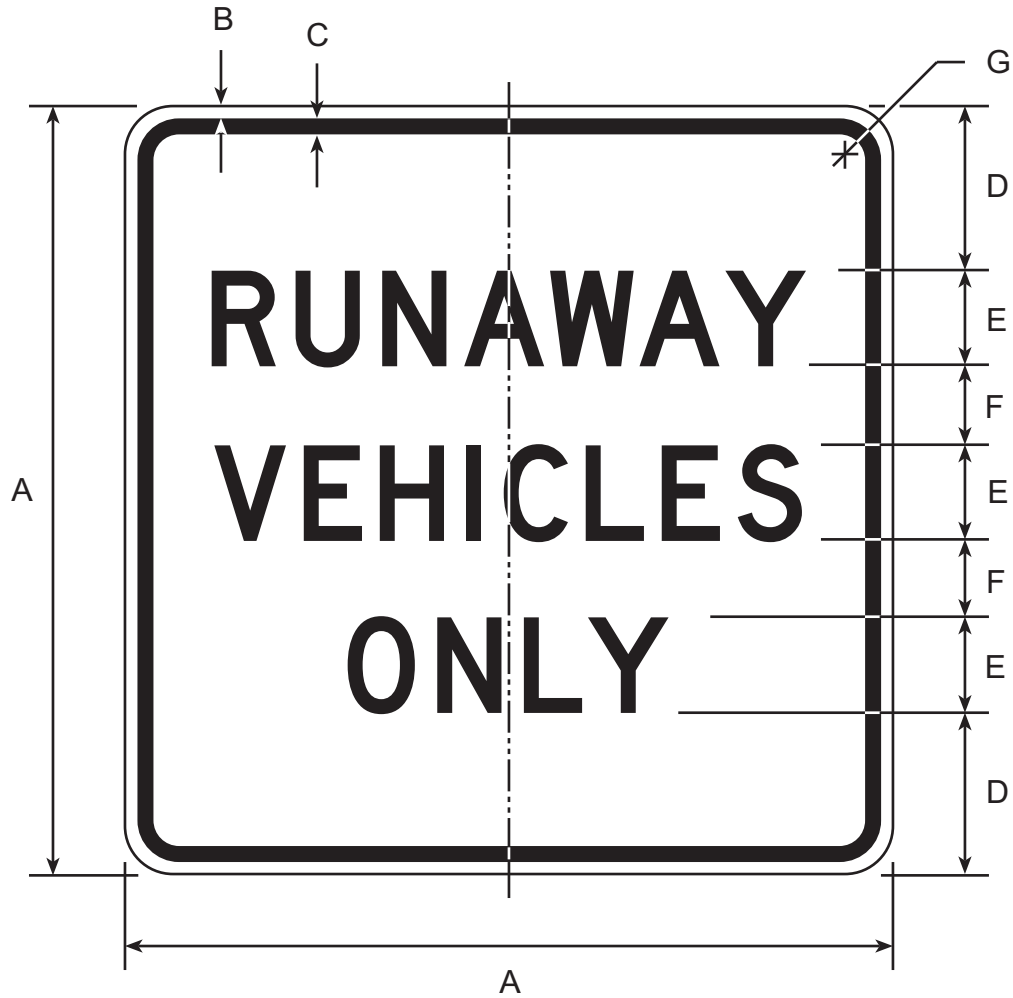

DIMENSIONS (MILLIMETERS)						
A	B	C	D	E	F	G
1200	19	31	250	150D	125	75

DIMENSIONS (INCHES)						
A	B	C	D	E	F	G
48	3/4	1 1/4	10	6D	5	3

COLORS

LEGEND - BLACK (NON-REFL)
BACKGROUND - WHITE (REFL)

R5-1B

3/06

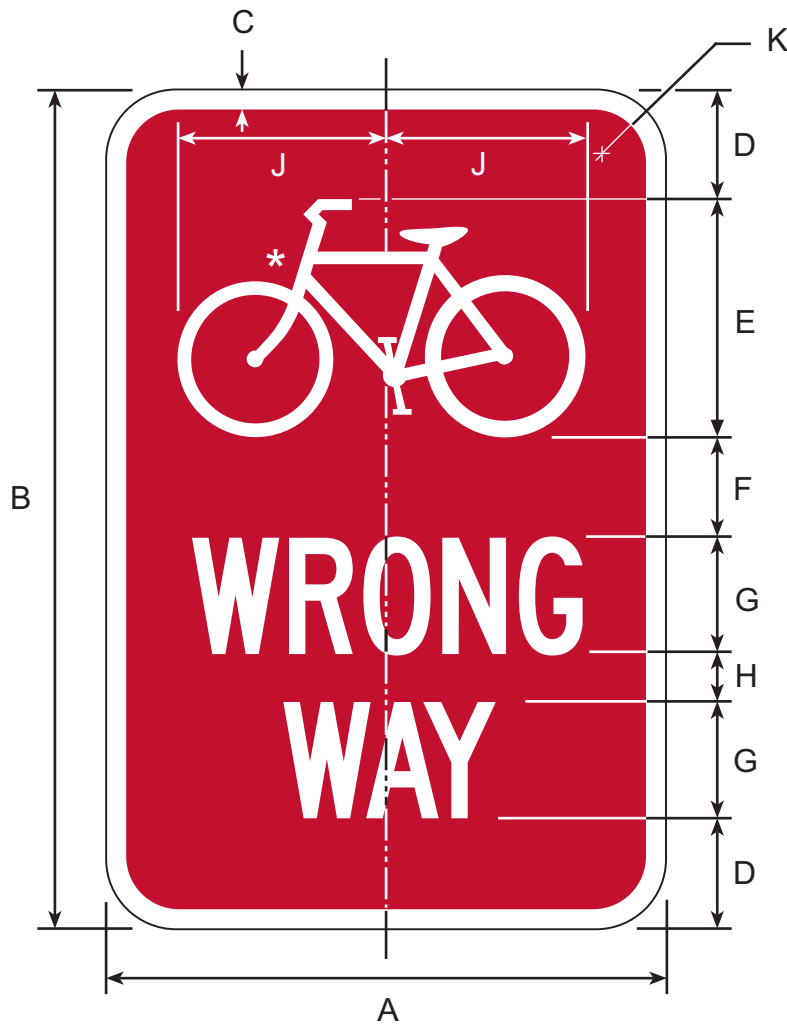

* SEE APPENDIX FOR STANDARD SYMBOL DETAILS

DIMENSIONS (MILLIMETERS)									
A	B	C	D	E	F	G	H	J	K
300	450	9	63	125	50	63C	25	108	38

DIMENSIONS (INCHES)									
A	B	C	D	E	F	G	H	J	K
12	18	3/8	2 1/2	5	2	2 1/2C	1	4 5/16	1 1/2

COLORS

LEGEND & SYMBOL - WHITE (REFL)
BACKGROUND - RED (REFL)

R6-1 L / R

5/06

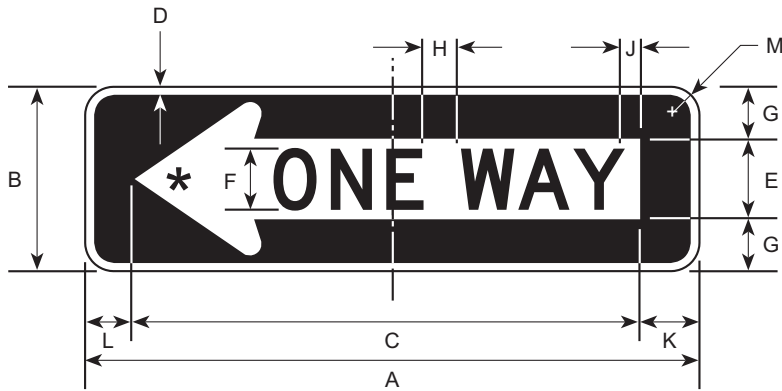

R6-1L

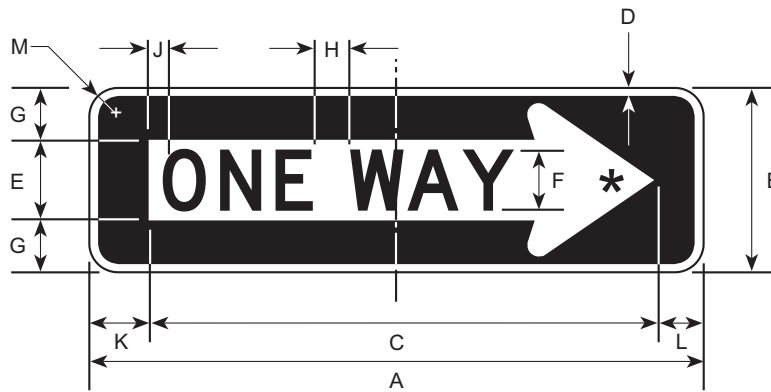

R6-1R

* See appendix for standard arrow details

DIMENSIONS (MILLIMETERS)											
A	B	C	D	E	F	G	H	J	K	L	M
900	300	775	13	131	100D	84	50	31	75	50	38
1350	450	1125	25	175	125D	138	75	100	125	100	47

DIMENSIONS (INCHES)											
A	B	C	D	E	F	G	H	J	K	L	M
36	12	31	1/2	5 1/4	4D	3 3/8	2	1 1/4	3	2	1 1/2
54	18	45	1	3	5D	5 1/2	3	4	5	4	1 7/8

COLORS

LEGEND — BLACK (NON-REFL)
 ARROW & BORDER — WHITE (REFL)
 BACKGROUND — BLACK (NON-REFL)

R6-2 L / R

11/97



* See appendix for standard arrow details
NOTE: Right shown only

DIMENSIONS (MILLIMETERS)												
A	B	C	D	E	F	G	H	J	K	L	M	N
450	600	9	16	63	125D	38	113	138	56	150	147	38
600	750	9	16	75	150D	47	152	177	75	200	194	38

DIMENSIONS (INCHES)												
A	B	C	D	E	F	G	H	J	K	L	M	N
18	24	3/8	5/8	2 1/2	5D	1 1/2	4 1/2	5 1/2	2 1/4	6	5 7/8	1 1/2
24	30	3/8	5/8	3	6D	1 7/8	6 1/16	7 1/16	3	8	7 3/4	1 1/2

COLORS

LEGEND — BLACK (NON-REFL)
BACKGROUND — WHITE (REFL)

R7-203

3/06



DIMENSIONS (MILLIMETERS)											
A	B	C	D	E	F	G	H	J	K	L	M
450	600	9	16	243	56	50D	44	88	50C	75	38
600	750	9	16	300	69	63D	56	119	63C	81	38

DIMENSIONS (INCHES)											
A	B	C	D	E	F	G	H	J	K	L	M
18	24	3/8	5/8	9 3/4	2 1/4	2D	1 3/4	3 1/2	2C	3	1 1/2
24	30	3/8	5/8	12	2 3/4	2 1/2D	2 1/4	4 3/4	2 1/2C	3 1/4	1 1/2

COLORS

- TOP LEGEND - WHITE (REFL)
- TOP BACKGROUND - RED (REFL)
- BOTTOM LEGEND - RED (REFL)
- BOTTOM BACKGROUND - WHITE (REFL)

R7-9

3/06



* REDUCE SPACING 15%

DIMENSIONS (MILLIMETERS)							
A	B	C	D	E	F	G	H
300	450	9	16	59	59B	25	44

J	K	L	M	N	P	Q
75C	47	69	75B	33	109	38

DIMENSIONS (INCHES)							
A	B	C	D	E	F	G	H
12	18	3/8	5/8	2	2B	1	1 3/4

J	K	L	M	N	P	Q
3C	1 7/8	2 3/4	3B	1 5/16	4 3/8	1 1/2

COLORS

LEGEND - RED (REFL) & WHITE (REFL)
 BACKGROUND - WHITE (REFL) & RED (REFL)

R7-9A

11/97

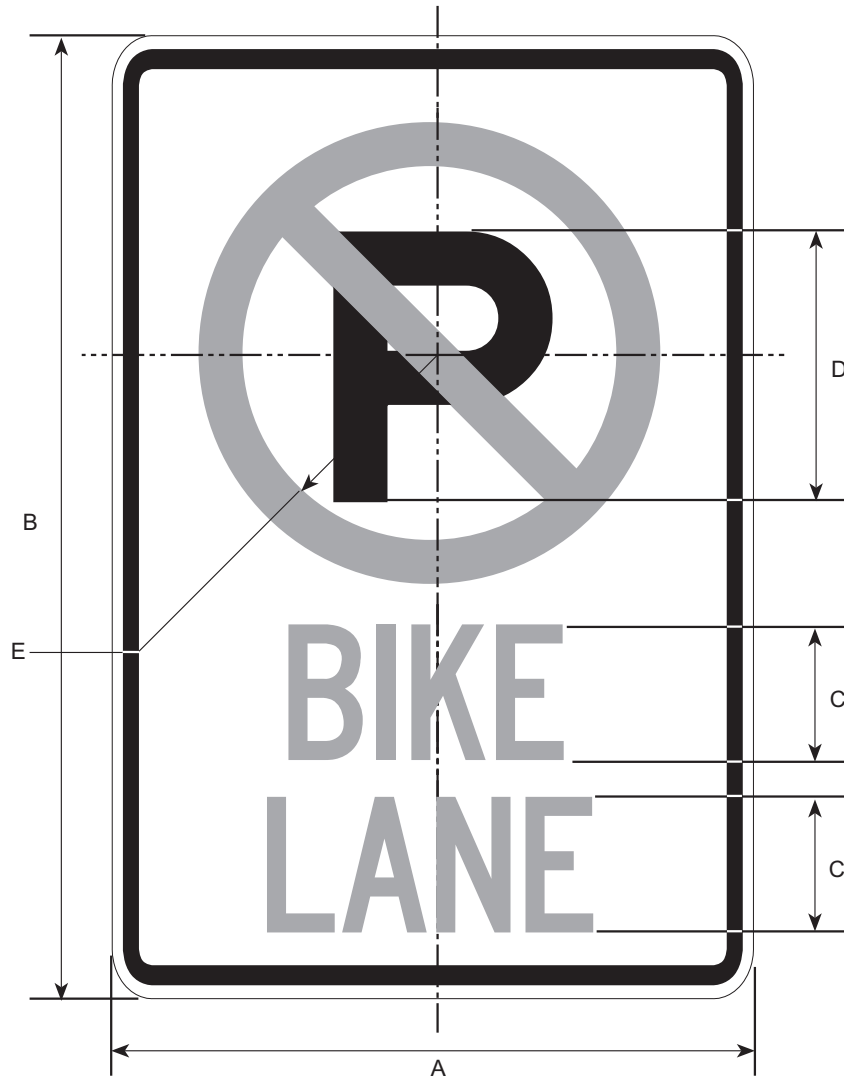

DIMENSIONS (MILLIMETERS)				
A	B	C	D	E
300	450	63C	125E(M)	85

DIMENSIONS (INCHES)				
A	B	C	D	E
12	18	2 1/2C	5E(M)	3 3/8

COLORS

LEGEND, CIRCLE, DIAGONAL — RED

BACKGROUND — WHITE

LETTER P, BORDER — BLACK

R8-3C

3/06

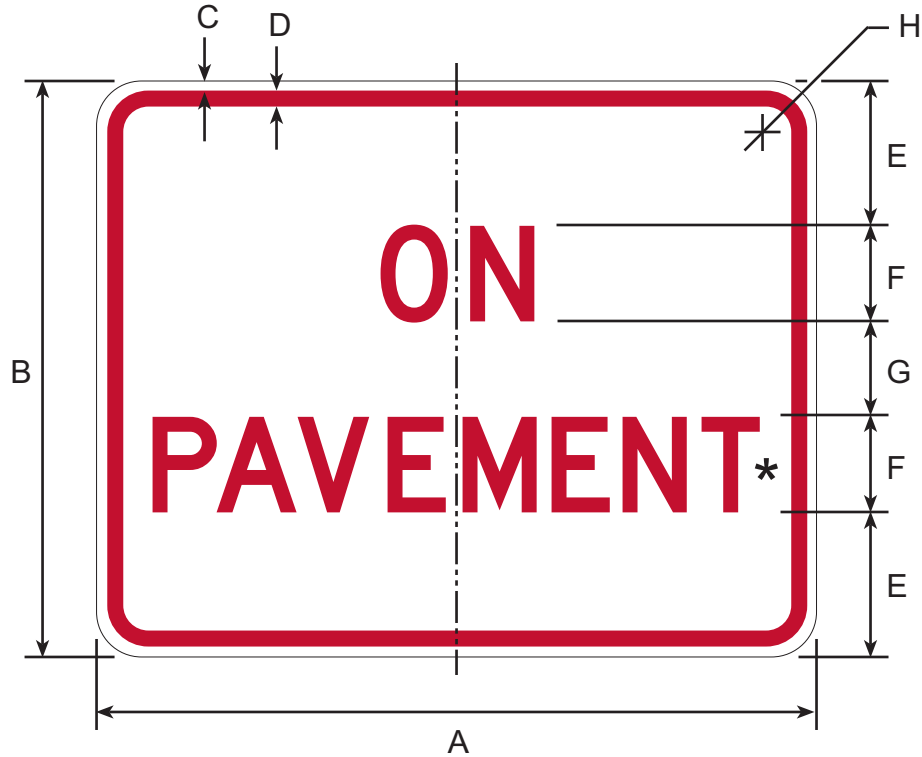

* REDUCE SPACING TO FIT FOR 30" (750MM) WIDE SIGN

DIMENSIONS (MILLIMETERS)							
A	B	C	D	E	F	G	H
300	225	9	11	66	34D	25	38
450	300	9	16	75	50D	50	38
600	450	9	16	119	75D	62	38
750	600	13	19	150	100D	100	47

DIMENSIONS (INCHES)							
A	B	C	D	E	F	G	H
12	9	3/8	7/16	2 5/8	1 3/8D	1	1 1/2
18	12	3/8	5/8	3	2D	2	1 1/2
24	18	3/8	5/8	4 3/4	3D	2 1/2	1 1/2
30	24	1/2	3/4	6	4D	4	1 7/8

COLORS

LEGEND - RED (REFL)
BACKGROUND - WHITE (REFL)

R8-3D

3/06

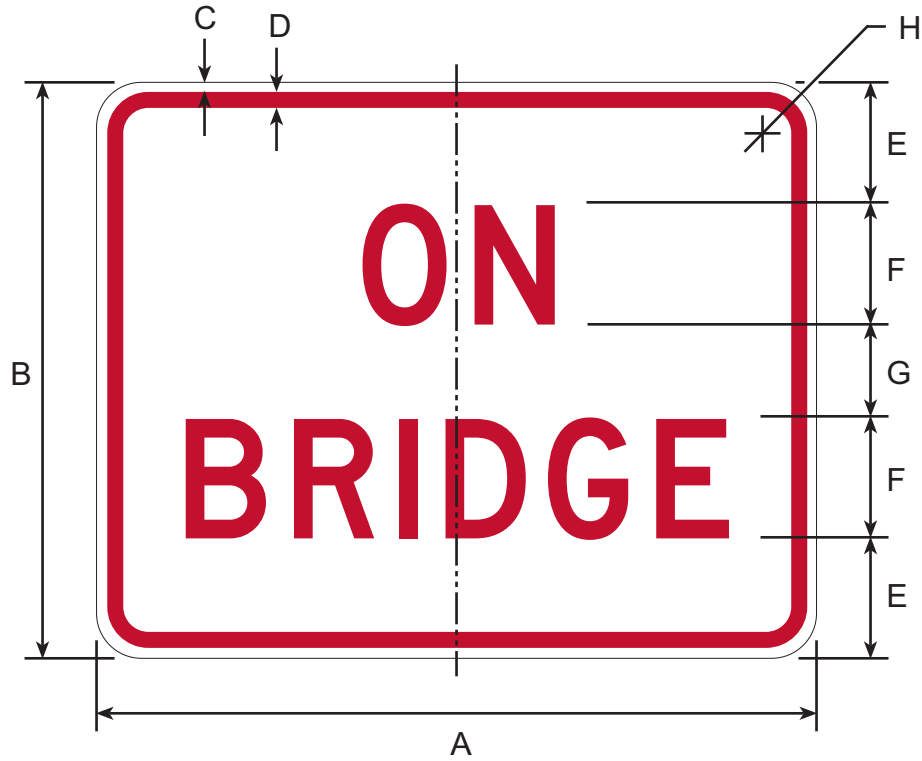

DIMENSIONS (MILLIMETERS)							
A	B	C	D	E	F	G	H
300	225	9	11	50	50D	25	38
450	300	9	16	50	75D	50	38
600	450	9	16	94	100D	63	38
750	600	13	19	125	125D	100	47

DIMENSIONS (INCHES)							
A	B	C	D	E	F	G	H
12	9	3/8	7/16	2	2D	1	1 1/2
18	12	3/8	5/8	2	3D	2	1 1/2
24	18	3/8	5/8	3 3/4	4D	2 1/2	1 1/2
30	24	1/2	3/4	5	5D	4	1 7/8

COLORS

LEGEND - RED (REFL)
BACKGROUND - WHITE (REFL)

R9-3B L/R

11/97

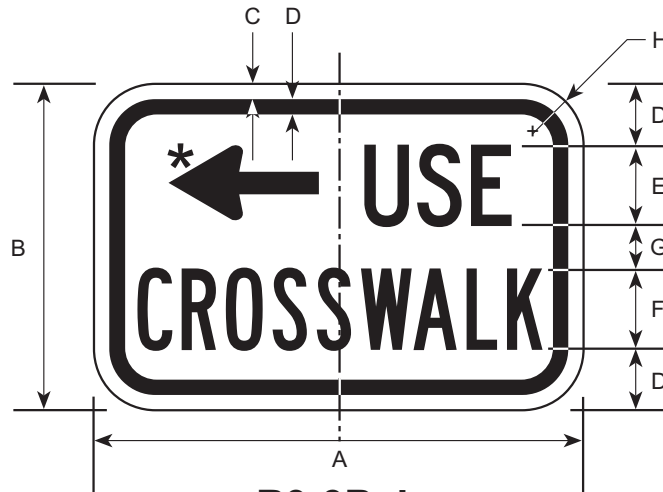

R9-3B L

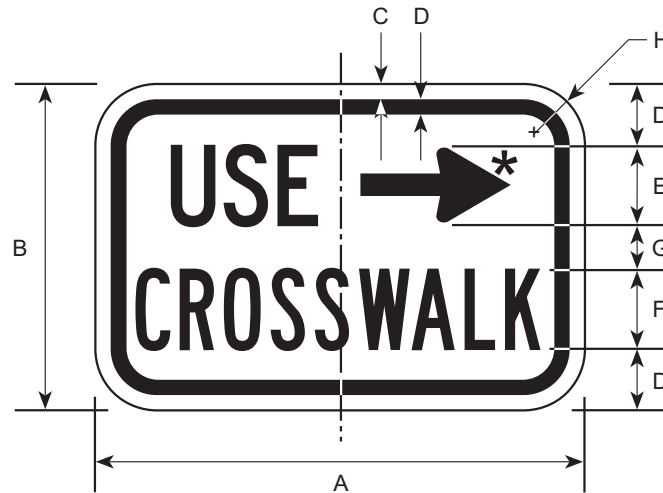

R9-3B R

* See appendix for standard arrow details

DIMENSIONS (MILLIMETERS)							
A	B	C	D	E	F	G	H
450	300	9	56	75C	75B	38	38

DIMENSIONS (INCHES)							
A	B	C	D	E	F	G	H
18	12	3/8	2.25	3C	3B	1 1/2	1 1/2

COLORS

LEGEND — BLACK (NON-REFL)
BACKGROUND — WHITE (REFL)

R9-3C

3/06

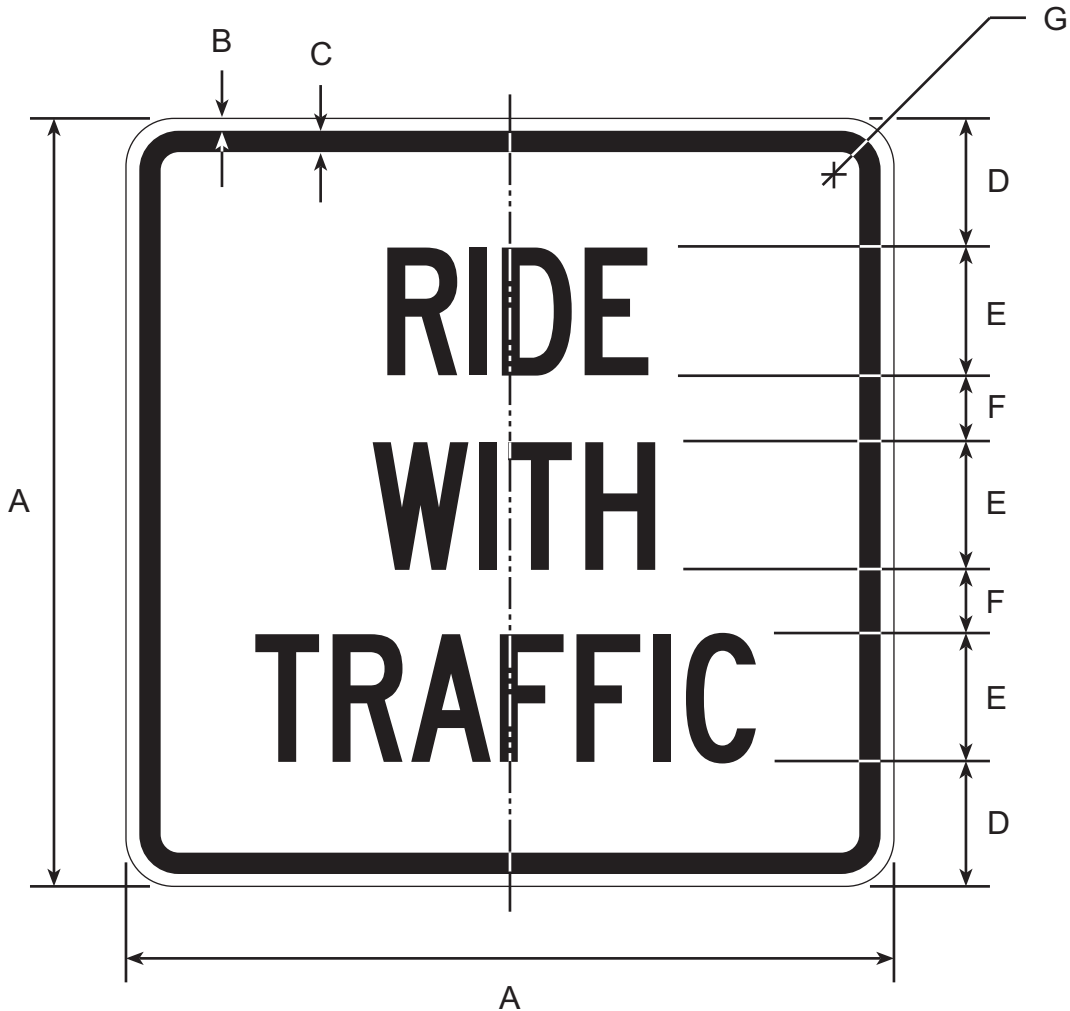

DIMENSIONS (MILLIMETERS)						
A	B	C	D	E	F	G
300	9	11	50	50C	25	38

DIMENSIONS (INCHES)						
A	B	C	D	E	F	G
12	3/8	7/16	2	2C	1	1 1/2

COLORS

LEGEND - BLACK (NON-REFL)
 BACKGROUND - WHITE (REFL)

R9-4

11/97



DIMENSIONS (MILLIMETERS)								
A	B	C	D	E	F	G	H	J
450	600	9	16	75	150C	50	100C	38

DIMENSIONS (INCHES)								
A	B	C	D	E	F	G	H	J
18	24	3/8	5/8	3	6C	2	4C	1 1/2

COLORS

LEGEND — BLACK (NON-REFL)
 BACKGROUND — WHITE (REFL)

R10-6A

11/97

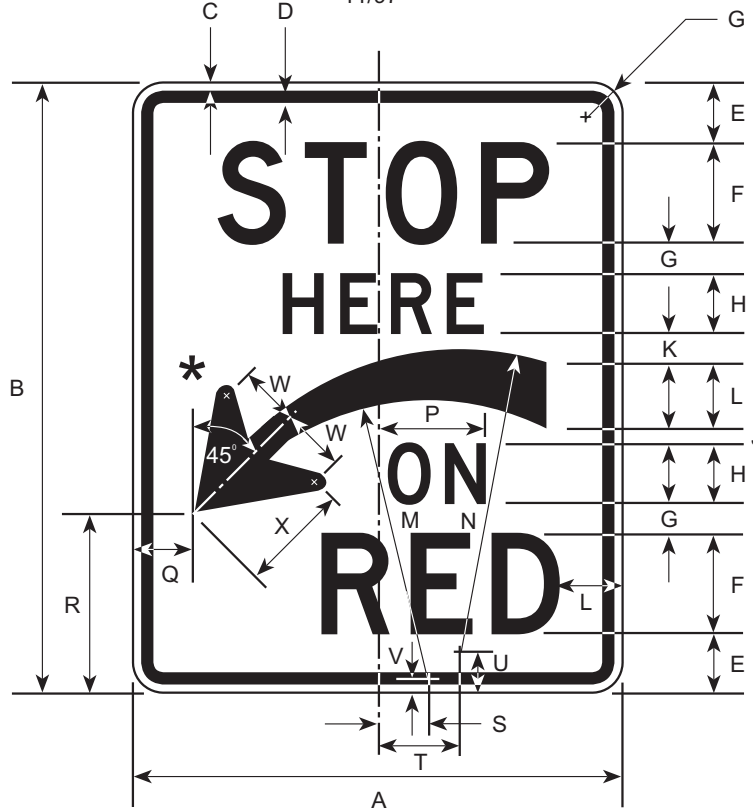

* See appendix for standard arrow details

DIMENSIONS (MILLIMETERS)										
A	B	C	D	E	F	G	H	J	K	L
600	750	9	16	75	125D	38	75D	13	31	81
M	N	P	Q	R	S	T	U	V	W	X
328	361	131	66	213	63	100	75D	19	80	134

DIMENSIONS (INCHES)										
A	B	C	D	E	F	G	H	J	K	L
24	30	3/8	5/8	3	5D	1 1/2	3D	1/2	1 1/4	3 1/4
M	N	P	Q	R	S	T	U	V	W	X
13 1/8	14 7/16	5 1/4	2 5/8	8 1/2	2 1/2	4	3D	3/4	3 3/16	5 3/8

COLORS

LEGEND — BLACK (NON-REFL)
 BACKGROUND — WHITE (REFL)

R10-601L

3/06

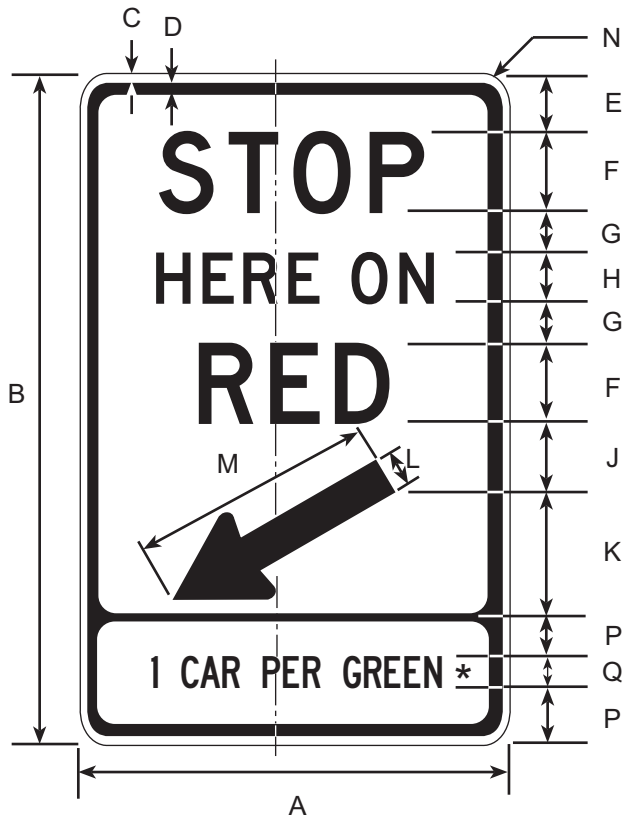

R10-601R



* - REDUCED SPACING

DIMENSIONS (MILLIMETERS)							
A	B	C	D	E	F	G	H
600	1050	9	16	100	125D	63	75D

J	K	L	M	N	P	Q
113	238	66	366	38	50	50C

DIMENSIONS (INCHES)							
A	B	C	D	E	F	G	H
24	42	3/8	5/8	4	5D	2 1/2	3D

J	K	L	M	N	P	Q
4 1/2	9 1/2	2 5/8	14 5/8	1 1/2	2	2C

COLORS

LEGEND — BLACK (NON-REFL)
BACKGROUND — WHITE (REFL)

R10-8

11/97

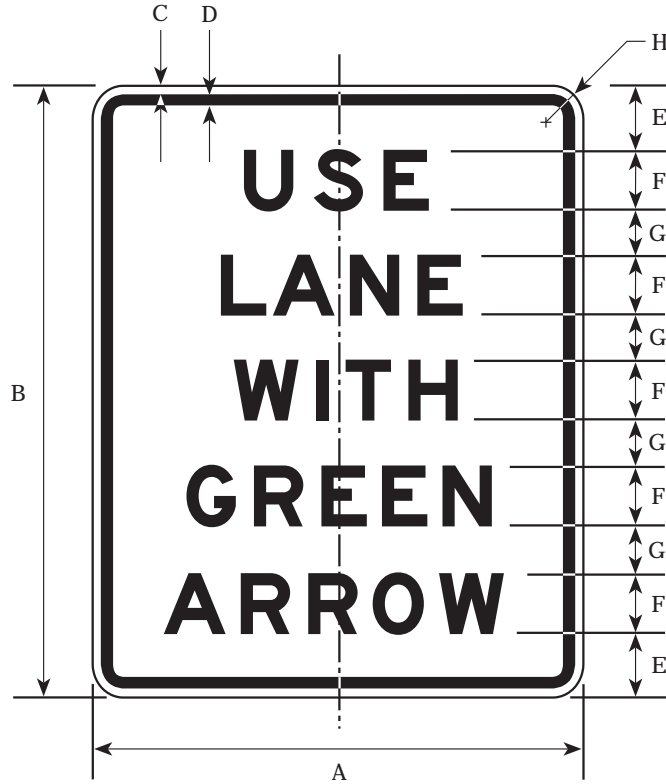

DIMENSIONS (MILLIMETERS)							
A	B	C	D	E	F	G	H
450	600	9	16	75	50E	50	38
600	750	9	16	75	75E	56	38
750	900	13	19	75	100E	63	47

DIMENSIONS (INCHES)							
A	B	C	D	E	F	G	H
18	24	3/8	5/8	3	2E	2	1 1/2
24	30	3/8	5/8	3	3E	2 1/4	1 1/2
30	36	1/2	3/4	3	4E	2 1/2	1 7/8

COLORS

LEGEND - BLACK (NON-REFL)
 BACKGROUND - WHITE (REFL)

R10-10 L / R

11/97

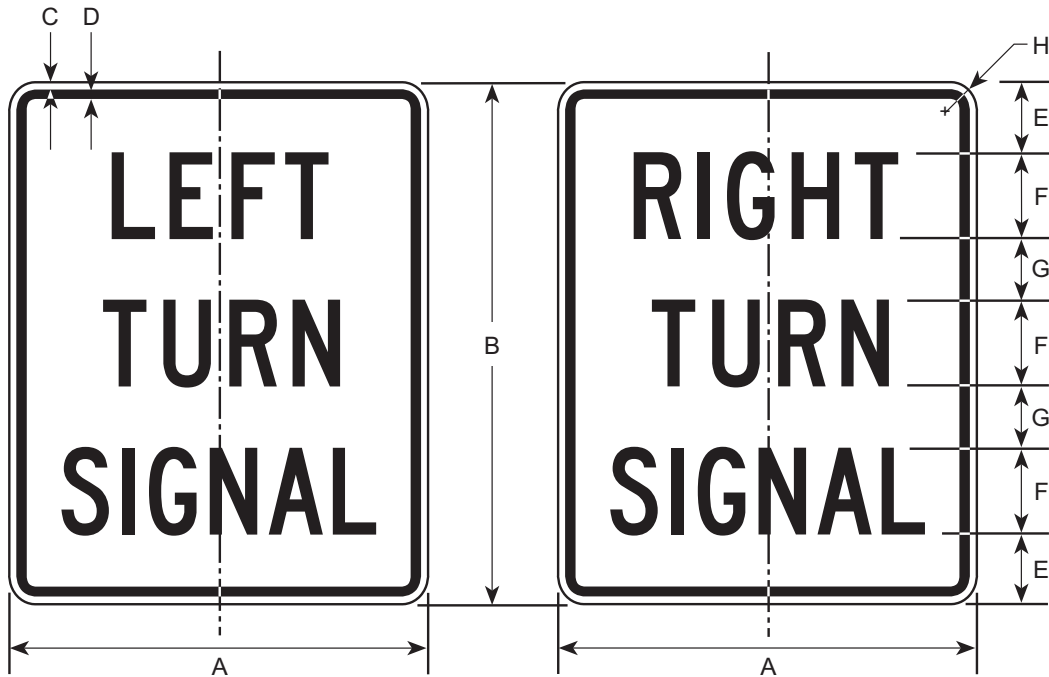

R10-10 L

R10-10 R

DIMENSIONS (MILLIMETERS)							
A	B	C	D	E	F	G	H
600	750	9	16	100	125C	88	38

DIMENSIONS (INCHES)							
A	B	C	D	E	F	G	H
24	30	3/8	5/8	4	5C	3 1/2	1 1/2

COLORS

LEGEND — BLACK (NON-REFL)
 BACKGROUND — WHITE (REFL)

R10-11

3/06

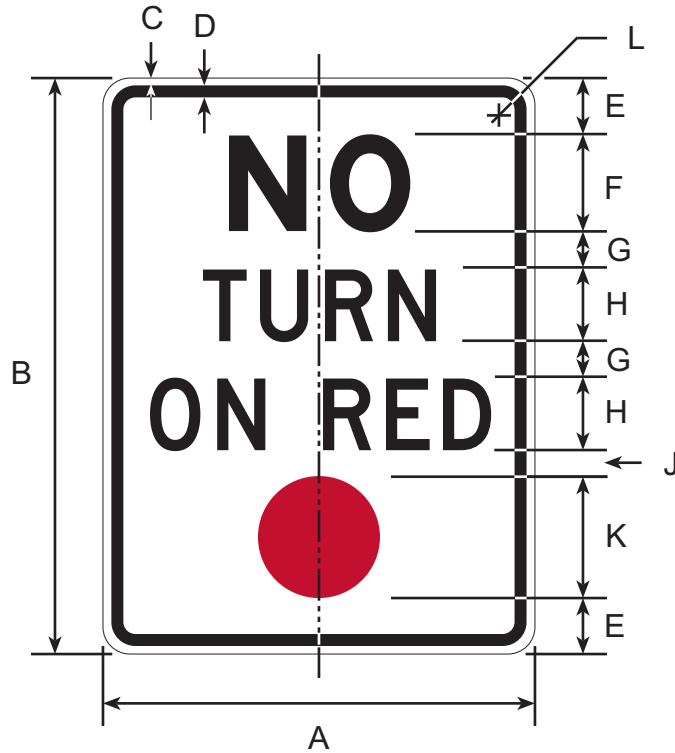

DIMENSIONS (MILLIMETERS)										
A	B	C	D	E	F	G	H	J	K	L
450	600	9	16	60	100E	44	75D	19	125	38
600	750	9	16	75	125E	50	100D	25	150	38
900	1200	16	22	106	200E	88	150D	38	250	56

DIMENSIONS (INCHES)										
A	B	C	D	E	F	G	H	J	K	L
18	24	3/8	5/8	2 3/8	4E	1 3/4	3D	3/4	5	1 1/2
24	30	3/8	5/8	3	5E	2	4D	1	6	1 1/2
36	48	5/8	7/8	4 1/4	8E	3 1/2	6D	1 1/2	10	2 1/4

COLORS

LEGEND - BLACK (NON-REFL)
 SYMBOL - RED (REFL)
 BACKGROUND - WHITE (REFL)

R10-11A

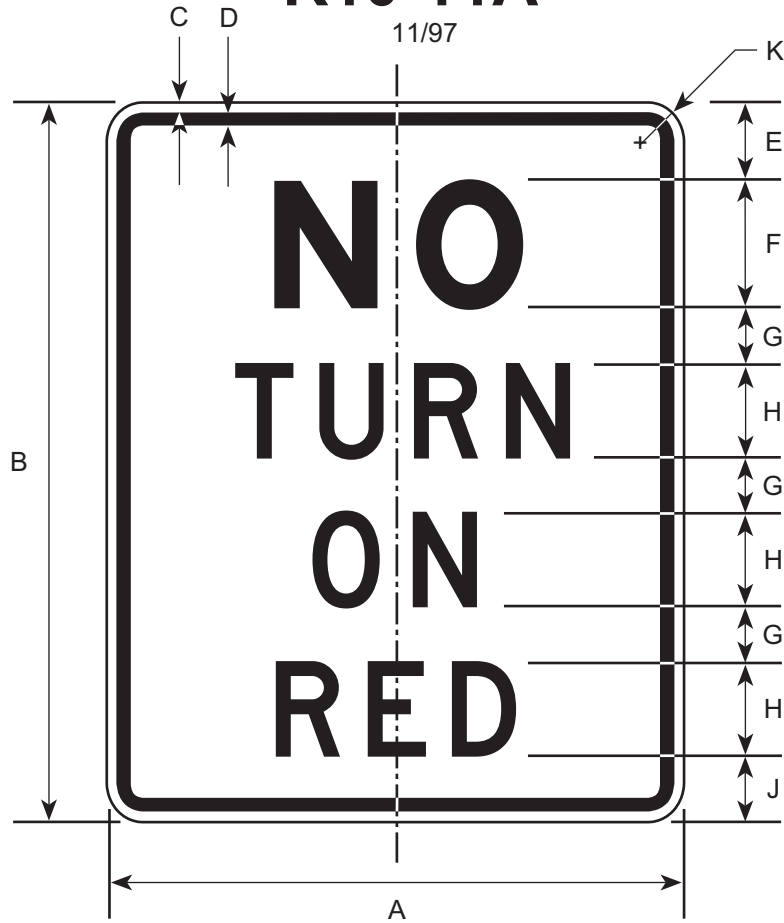

DIMENSIONS (MILLIMETERS)									
A	B	C	D	E	F	G	H	J	K
450	600	9	16	75	100E	44	75D	69	38
600	750	9	16	81	125E	56	100D	75	38
900	1200	16	22	150	200E	88	150D	138	56

DIMENSIONS (INCHES)									
A	B	C	D	E	F	G	H	J	K
18	24	3/8	5/8	3	4E	1 3/4	3D	2 3/4	1 1/2
24	30	3/8	5/8	3 1/4	5E	2 1/4	4D	3	1 1/2
36	48	5/8	7/8	6	8E	3 1/2	6D	5 1/2	2 1/4

COLORS

LEGEND — BLACK (NON-REFL)
 BACKGROUND — WHITE (REFL)

R10-11B

11/97

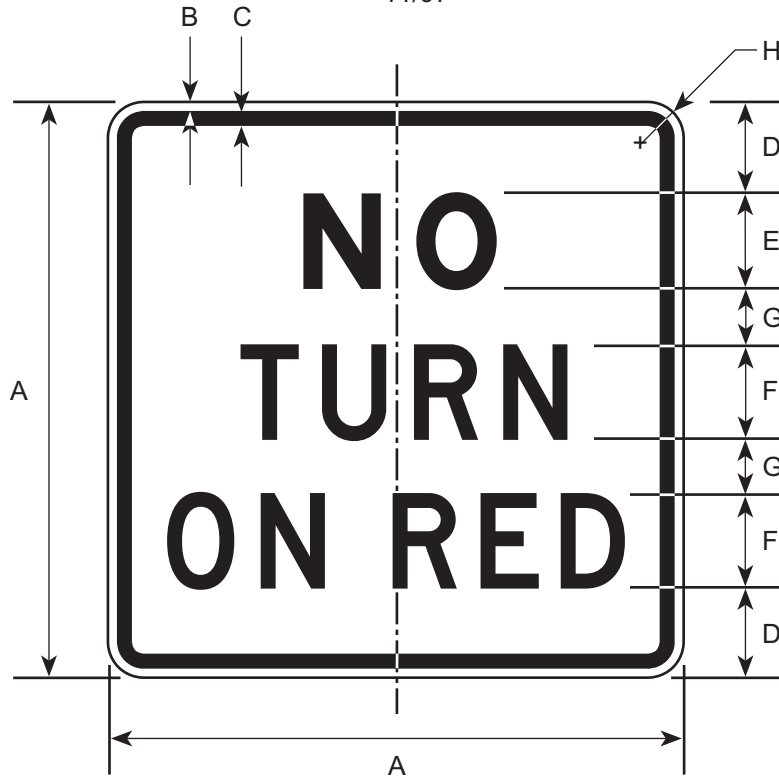

DIMENSIONS (MILLIMETERS)							
A	B	C	D	E	F	G	H
450	9	16	69	75E	75D	44	38
600	9	16	88	100E	100D	63	38
750	13	19	113	125E	125D	75	47

DIMENSIONS (INCHES)							
A	B	C	D	E	F	G	H
18	3/8	5/8	2 3/4	3E	3D	1 3/4	1 1/2
24	3/8	5/8	3 1/2	4E	4D	2 1/2	1 1/2
30	1/2	3/4	4 1/2	5E	5D	3	1 7/8

COLORS

LEGEND — BLACK (NON-REFL)
 BACKGROUND — WHITE (REFL)

R10-15

3/06

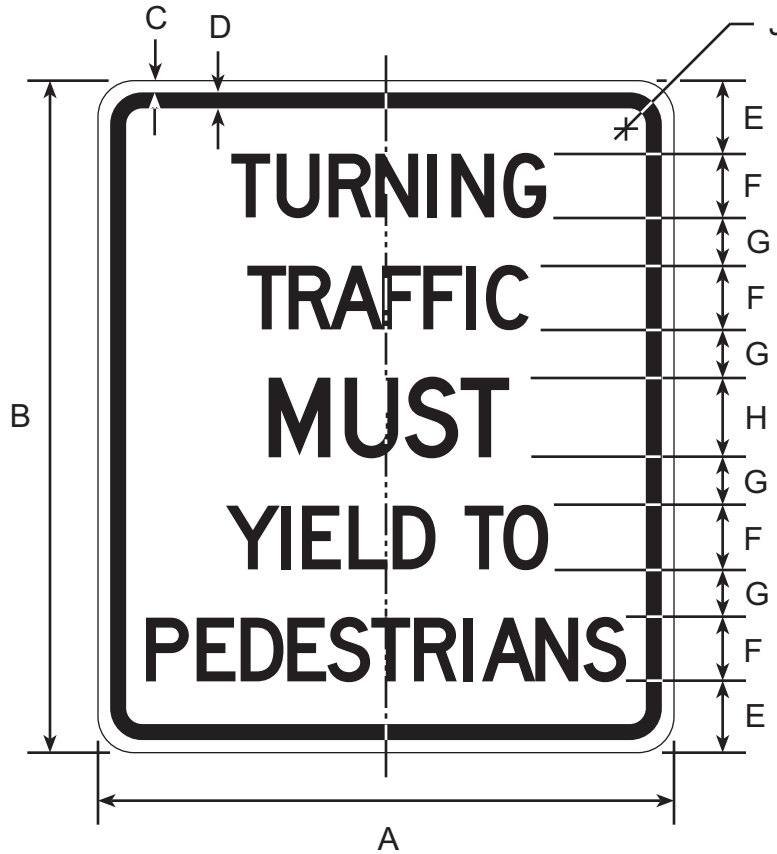

DIMENSIONS (MILLIMETERS)								
A	B	C	D	E	F	G	H	J
600	750	9	16	106	62D	50	88	38
750	900	13	19	113	75D	69	100	47
900	1050	16	22	113	100D	75	125	56

DIMENSIONS (INCHES)								
A	B	C	D	E	F	G	H	J
24	30	3/8	5/8	4 1/4	2 1/2D	2	3 1/2D	1 1/2
30	36	1/2	3/4	4 1/2	3D	2 3/4	4D	1 7/8
36	42	5/8	7/8	4 1/2	4D	3	5D	2 1/4

COLORS

LEGEND - BLACK (NON-REFL)
BACKGROUND - WHITE (REFL)

R10-16

3/06

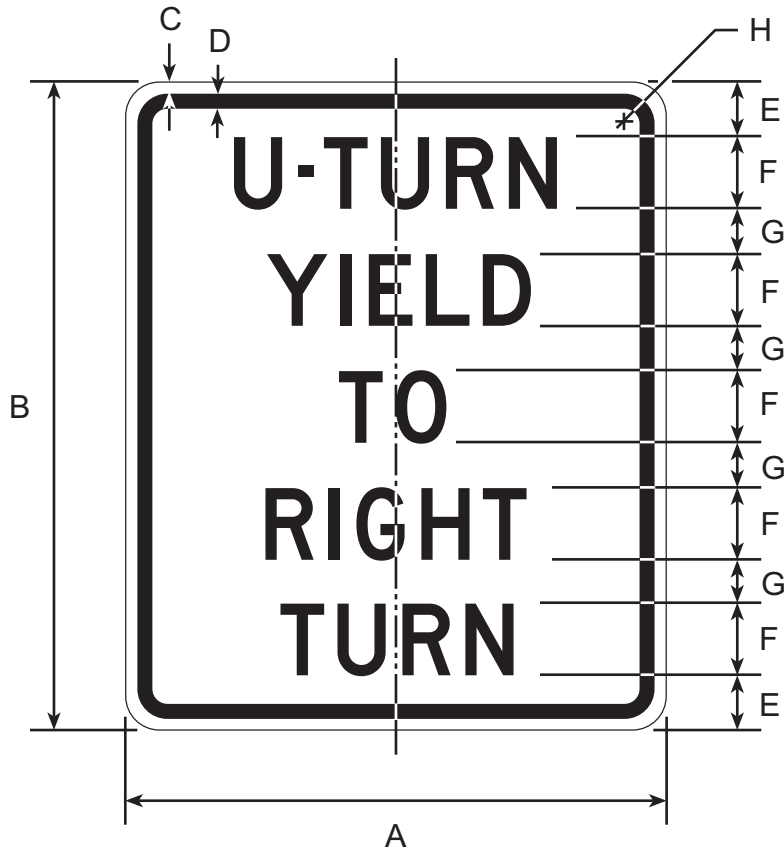

DIMENSIONS (MILLIMETERS)							
A	B	C	D	E	F	G	H
450	600	9	16	75	50D	50	38
600	750	9	16	75	75D	56	38
750	900	13	19	75	100D	62	47

DIMENSIONS (INCHES)							
A	B	C	D	E	F	G	H
18	24	3/8	5/8	3	2D	2	1 1/2
24	30	3/8	5/8	3	3D	2 1/4	1 1/2
30	36	1/2	3/4	3	4D	2 1/2	1 7/8

COLORS

LEGEND - BLACK (NON-REFL)
BACKGROUND - WHITE (REFL)

R10-17A

3/06

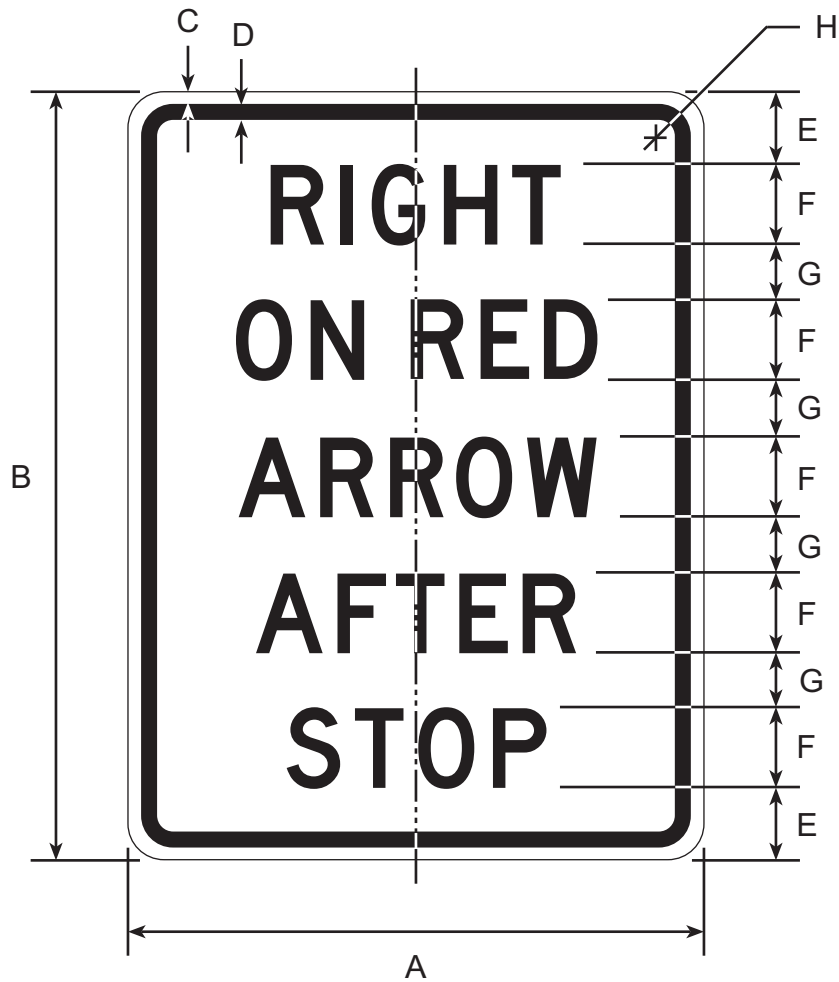

DIMENSIONS (MILLIMETERS)							
A	B	C	D	E	F	G	H
750	900	13	19	88	100D	56	47
900	1200	16	22	113	125D	88	56

DIMENSIONS (INCHES)							
A	B	C	D	E	F	G	H
30	36	1/2	3/4	3 1/2	4D	2 1/4	1 7/8
36	48	5/8	7/8	4 1/2	5D	3 1/2	2 1/4

COLORS

LEGEND - BLACK (NON-REFL)
BACKGROUND - WHITE (REFL)

R10-18

3/06

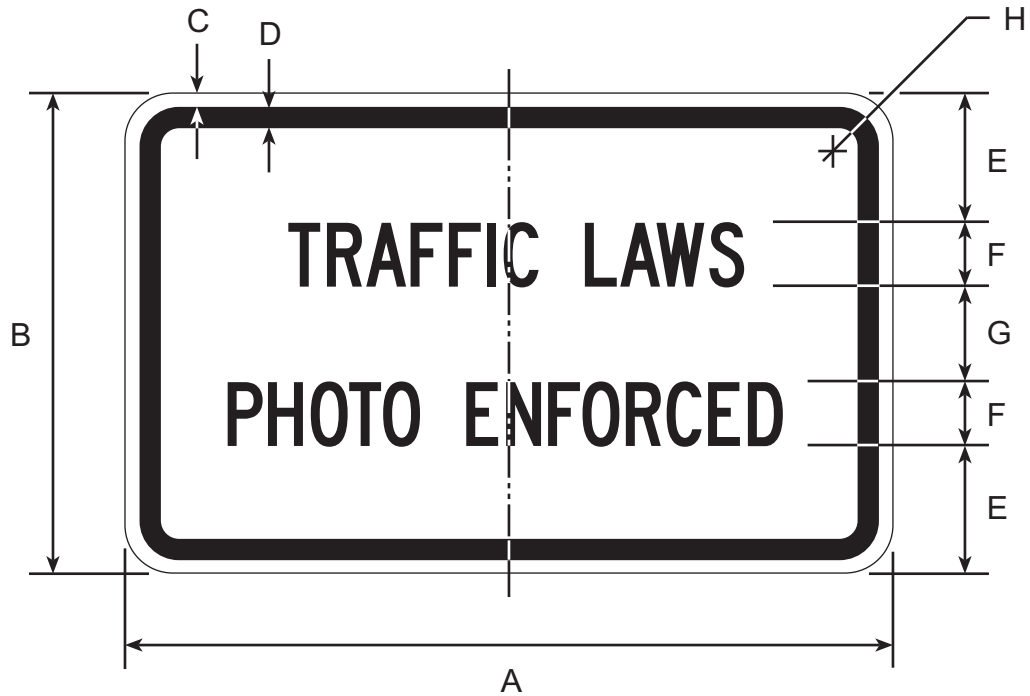

DIMENSIONS (MILLIMETERS)							
A	B	C	D	E	F	G	H
600	300	9	16	75	50C	50	38
900	450	16	22	113	75C	75	56
1200	750	19	31	200	100C	150	75
1800	900	25	31	225	150C	150	75

DIMENSIONS (INCHES)							
A	B	C	D	E	F	G	H
24	12	3/8	5/8	3	2C	2	1 1/2
36	18	5/8	7/8	4 1/2	3C	3	2 1/4
48	30	3/4	1 1/4	8	4C	6	3
72	36	1	1 1/4	9	6C	6	3

COLORS

LEGEND - BLACK (NON-REFL)
BACKGROUND - WHITE (REFL)

R10-19

3/06

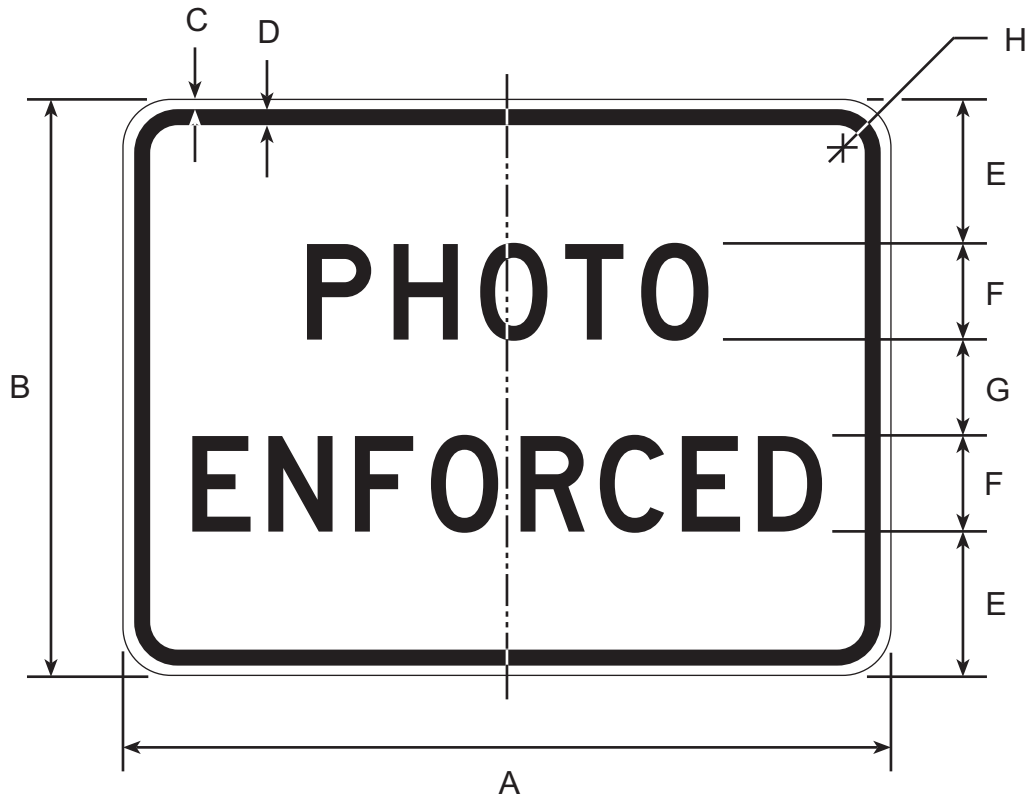

DIMENSIONS (MILLIMETERS)							
A	B	C	D	E	F	G	H
600	450	9	16	113	75D	75	38
900	750	16	22	200	100D	150	56
1200	900	19	31	225	150D	150	75

DIMENSIONS (INCHES)							
A	B	C	D	E	F	G	H
24	18	3/8	5/8	4 1/2	3D	3	1 1/2
36	30	5/8	7/8	8	4D	6	2 1/4
48	36	3/4	1 1/4	9	6D	6	3

COLORS

LEGEND - BLACK (NON-REFL)
BACKGROUND - WHITE (REFL)

R10-20A

3/06

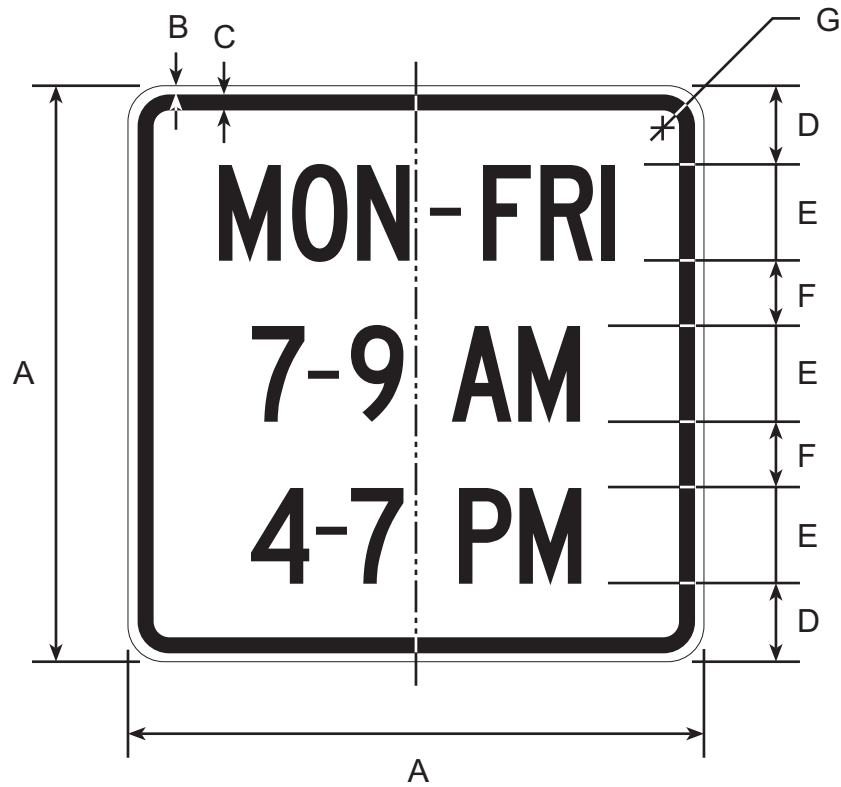

DIMENSIONS (MILLIMETERS)						
A	B	C	D	E	F	G
600	9	16	88	100C	62	38
750	13	19	113	125C	75	47
1200	19	31	175	200C	125	75

DIMENSIONS (INCHES)						
A	B	C	D	E	F	G
24	3/8	5/8	3 1/2	4C	2 1/2	1 1/2
30	1/2	3/4	4 1/2	5C	3	1 7/8
48	3/4	1 1/4	7	8C	5	3

COLORS

LEGEND - BLACK (NON-REFL)
BACKGROUND - WHITE (REFL)

R10-20B

3/06

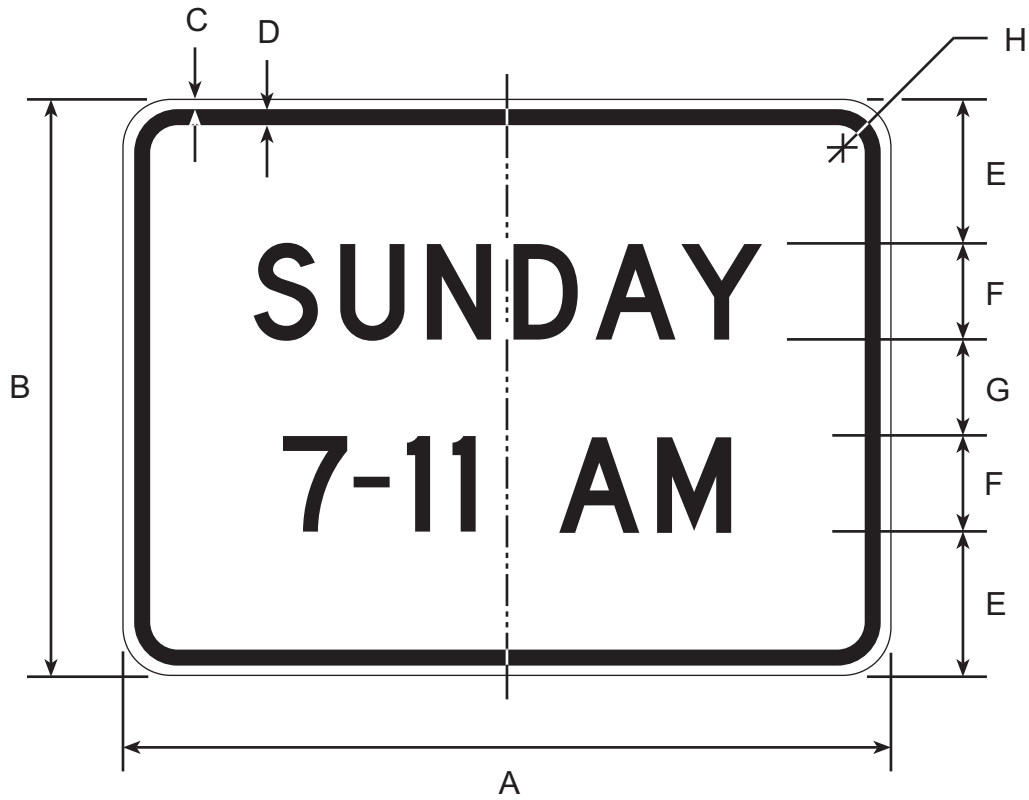

DIMENSIONS (MILLIMETERS)							
A	B	C	D	E	F	G	H
600	450	9	16	113	75D	75	38
750	600	13	19	150	100D	100	47
1200	900	19	31	225	150D	150	75

DIMENSIONS (INCHES)							
A	B	C	D	E	F	G	H
24	18	3/8	5/8	4 1/2	3D	3	1 1/2
30	24	1/2	3/4	6	4D	4	1 7/8
48	36	3/4	1 1/4	9	6D	6	3

COLORS

LEGEND - BLACK (NON-REFL)
BACKGROUND - WHITE (REFL)

R10-21

3/06

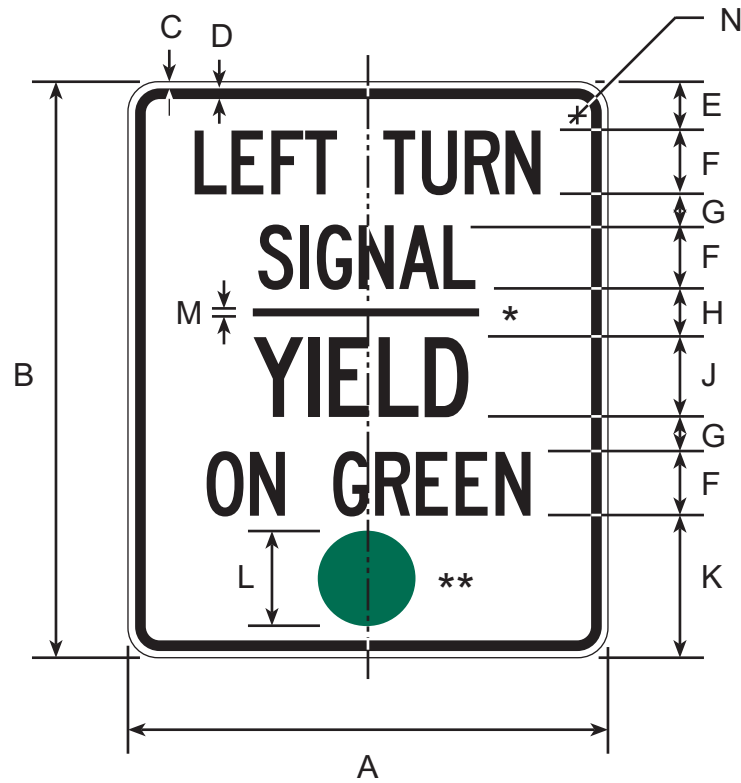

* Optically center between lines 2 & 3

** Optically center between line 4 & bottom border

DIMENSIONS (MILLIMETERS)												
A	B	C	D	E	F	G	H	J	K	L	M	N
450	600	9	16	50	62C	25	62	75C	175	125	9	38
600	750	9	16	62	75C	41	75	100C	206	150	16	38
750	900	13	19	75	100C	50	75	125C	225	175	19	47

DIMENSIONS (INCHES)												
A	B	C	D	E	F	G	H	J	K	L	M	N
18	24	3/8	5/8	2	2 1/2C	1	2 1/2	3C	7	5	3/8	1 1/2
24	30	3/8	5/8	2 1/2	3C	1 5/8	3	4C	8 1/4	6	5/8	1 1/2
30	36	1/2	3/4	3	4C	2	3	5C	9	7	3/4	1 7/8

COLORS

LEGEND - BLACK (NON-REFL)
 BALL - GREEN (REFL)
 BACKGROUND - WHITE (REFL)

R10-22

3/06

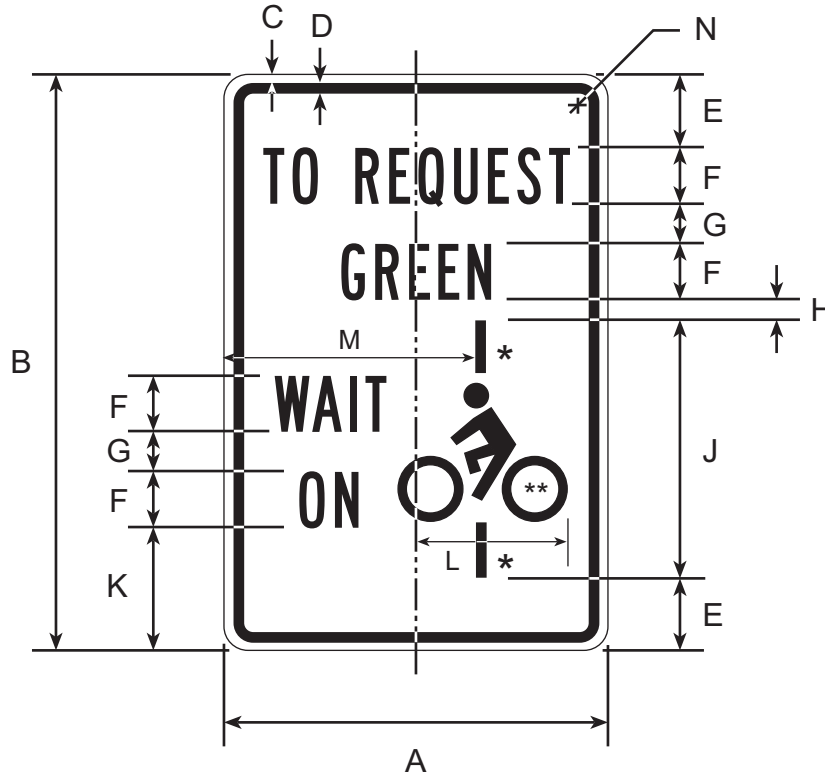

* Pavement marking depictions (2) are 1/2" x 1 3/4"

** See appendix for bicyclist symbol pattern

DIMENSIONS (MILLIMETERS)												
A	B	C	D	E	F	G	H	J	K	L	M	N
300	450	9	11	56	44B	31	25	200	97	116	175	38

DIMENSIONS (INCHES)												
A	B	C	D	E	F	G	H	J	K	L	M	N
12	18	3/8	7/16	2 1/4	1 3/4B	1 1/4	1	8	3 7/8	4 5/8	7	1 1/2

COLORS

LEGEND & SYMBOL - BLACK (NON-REFL)
 BACKGROUND - WHITE (REFL)

R12-5

11/97

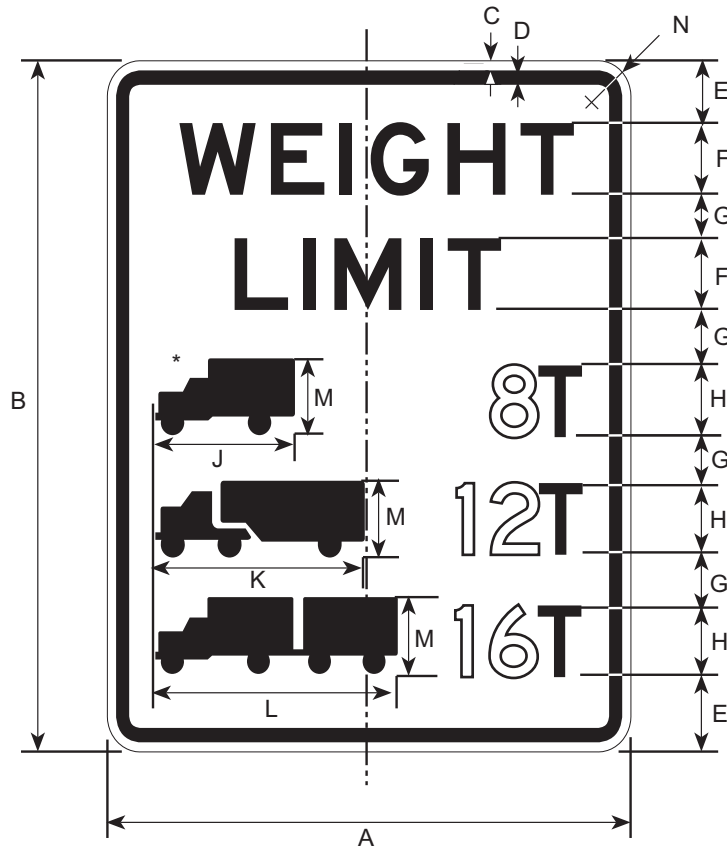

*See appendix for symbol design.

DIMENSIONS (MILLIMETERS)												
A	B	C	D	E	F	G	H	J	K	L	M	N
600	750	10	16	75	75E	56	75D	150	238	275	75	63
750	900	13	19	88	100E	56	100D	200	300	366	100	72
900	1200	16	22	125	125E	81	125D	250	375	460	125	56
1200	1500	19	31	150	150E	113	150D	300	450	550	150	75

DIMENSIONS (INCHES)												
A	B	C	D	E	F	G	H	J	K	L	M	N
24	30	3/8	5/8	3	3E	2 1/4	3D	6	9 1/2	11	3	1 1/2
30	36	1/2	3/4	3 1/2	4E	2 1/4	4D	8	12	14 5/8	4	1 7/8
36	48	5/8	7/8	5	5E	3 1/4	5D	10	15	18 3/8	5	2 1/4
48	60	3/4	1 1/4	6	6E	4 1/2	6D	12	18	22	6	3

COLORS

LEGEND — BLACK (NON-REFL)
 BACKGROUND — WHITE (REFL)

R12-501

4/06

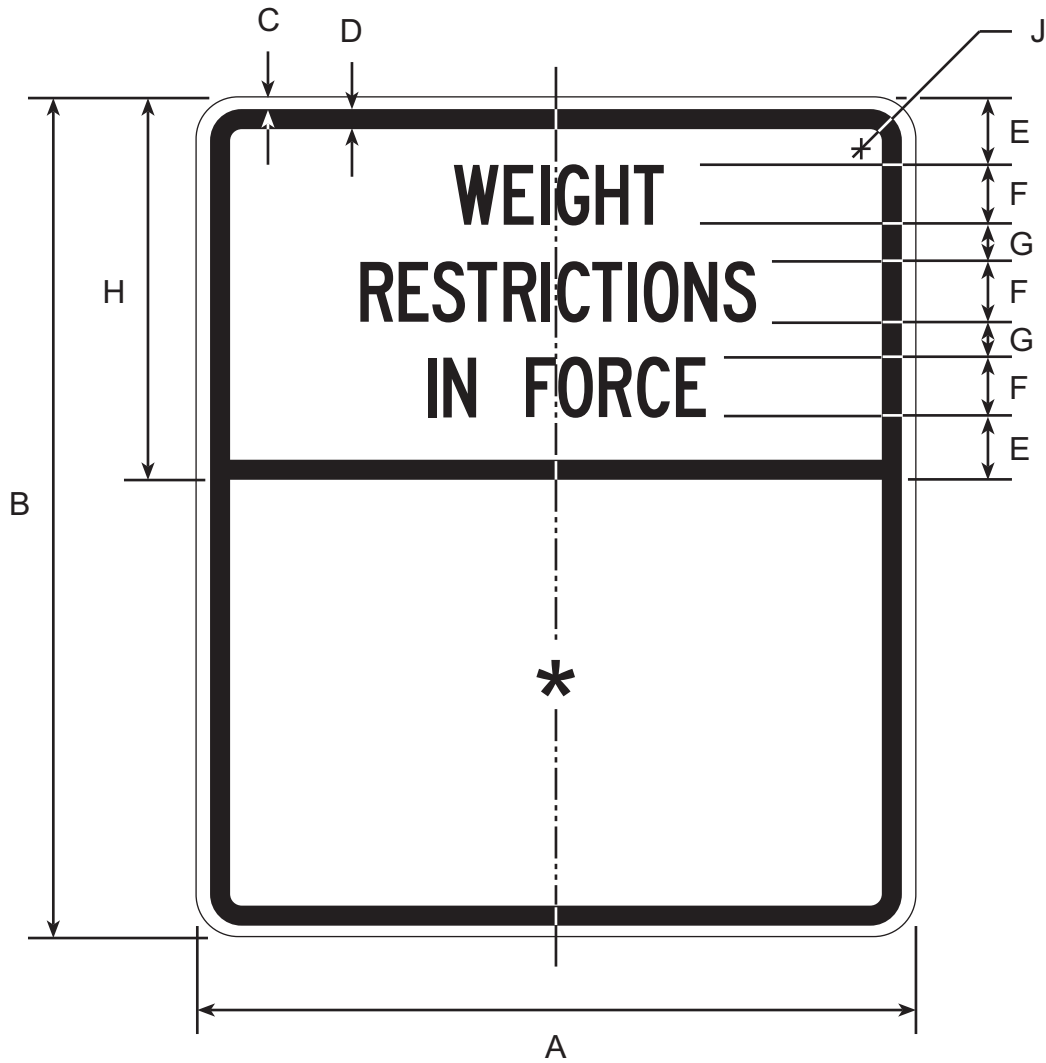

* This space reserved for legal notice

DIMENSIONS (MILLIMETERS)								
A	B	C	D	E	F	G	H	J
900	1050	9	16	3	75C	50	475	38

DIMENSIONS (INCHES)								
A	B	C	D	E	F	G	H	J
36	42	3/8	5/8	3	3C	2	19	1 1/2

COLOR

LEGEND - BLACK (NON-REFL)
BACKGROUND - WHITE (REFL)

R14-1

11/97

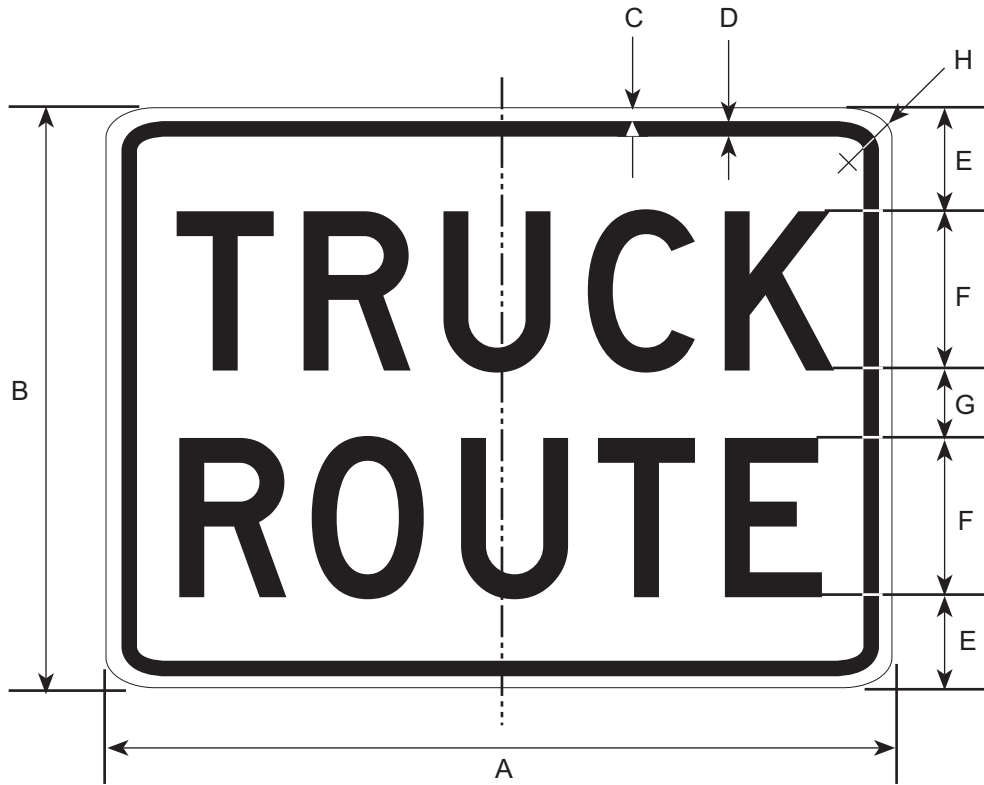

DIMENSIONS (MILLIMETERS)							
A	B	C	D	E	F	G	H
600	450	10	16	75	125D	50	38

DIMENSIONS (INCHES)							
A	B	C	D	E	F	G	H
24	18	3/8	5/8	3	5D	2	1 1/2

COLORS

LEGEND — BLACK (NON-REFL)
 BACKGROUND — WHITE (REFL)

R14-2

4/06

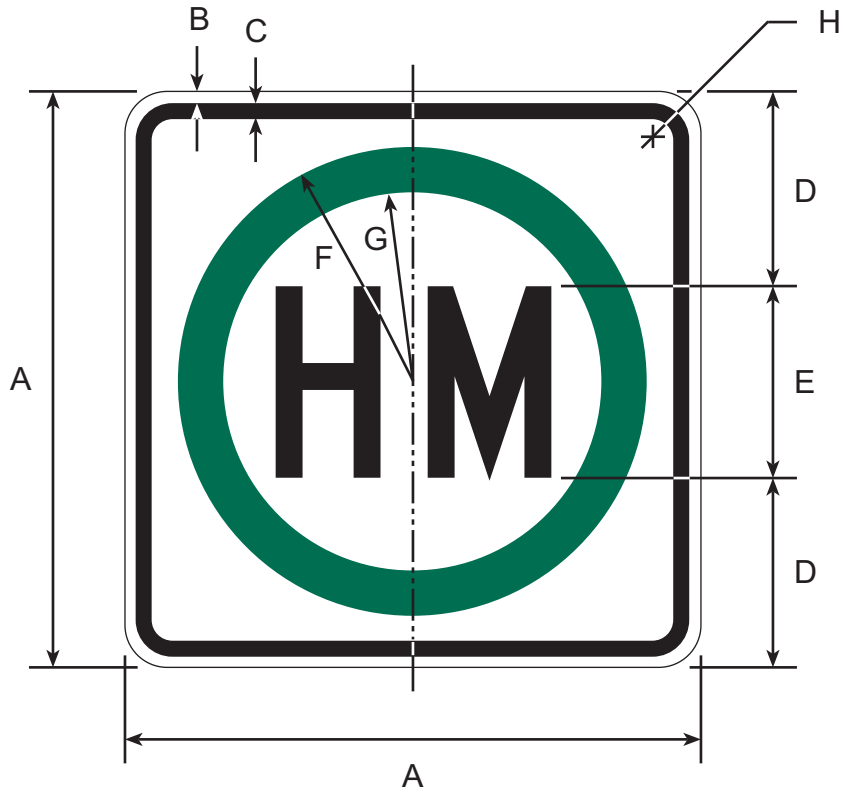

DIMENSIONS (MILLIMETERS)							
A	B	C	D	E	F	G	H
600	9	16	187	187C	250	200	38
750	13	19	250	250C	313	250	47
900	16	22	300	300C	375	300	56
1050	16	22	350	350C	438	350	56

DIMENSIONS (INCHES)							
A	B	C	D	E	F	G	H
24	3/8	5/8	7 1/2	9C	10	8	1 1/2
30	1/2	3/4	10	10C	12 1/2	10	1 7/8
36	5/8	7/8	12	12C	15	12	2 1/4
42	5/8	7/8	14	14C	17 1/2	14	2 1/4

COLORS

LETTERS & BORDER - BLACK (NON-REFL)
 CIRCLE - GREEN (REFL)
 BACKGROUND - WHITE (REFL)

R14-3

4/06

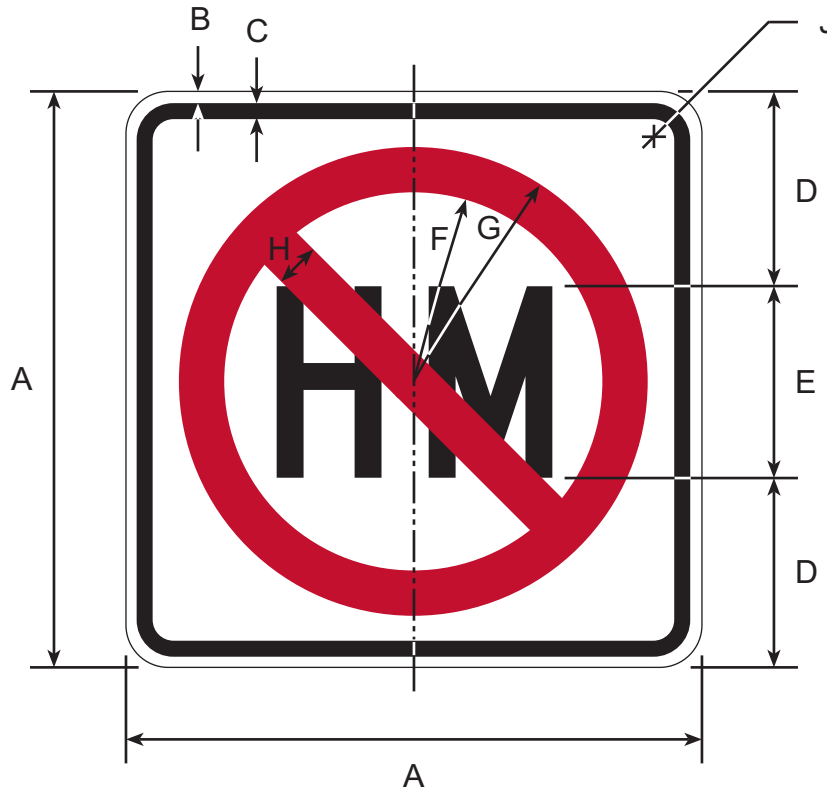

DIMENSIONS (MILLIMETERS)								
A	B	C	D	E	F	G	H	J
600	9	16	187	187C	200	250	50	38
750	13	19	250	250C	250	313	63	47
900	16	22	300	300C	300	375	75	56
1050	16	22	350	350C	350	438	88	56

DIMENSIONS (INCHES)								
A	B	C	D	E	F	G	H	J
24	3/8	5/8	7 1/2	9C	8	10	2	1 1/2
30	1/2	3/4	10	10C	10	12 1/2	2 1/2	1 7/8
36	5/8	7/8	12	12C	12	15	3	2 1/4
42	5/8	7/8	14	14C	14	17 1/2	3 1/2	2 1/4

COLORS

LETTERS & BORDER - BLACK (NON-REFL)
 CIRCLE & DIAGONAL - RED (REFL)
 BACKGROUND - WHITE (REFL)

R14-4

11/97

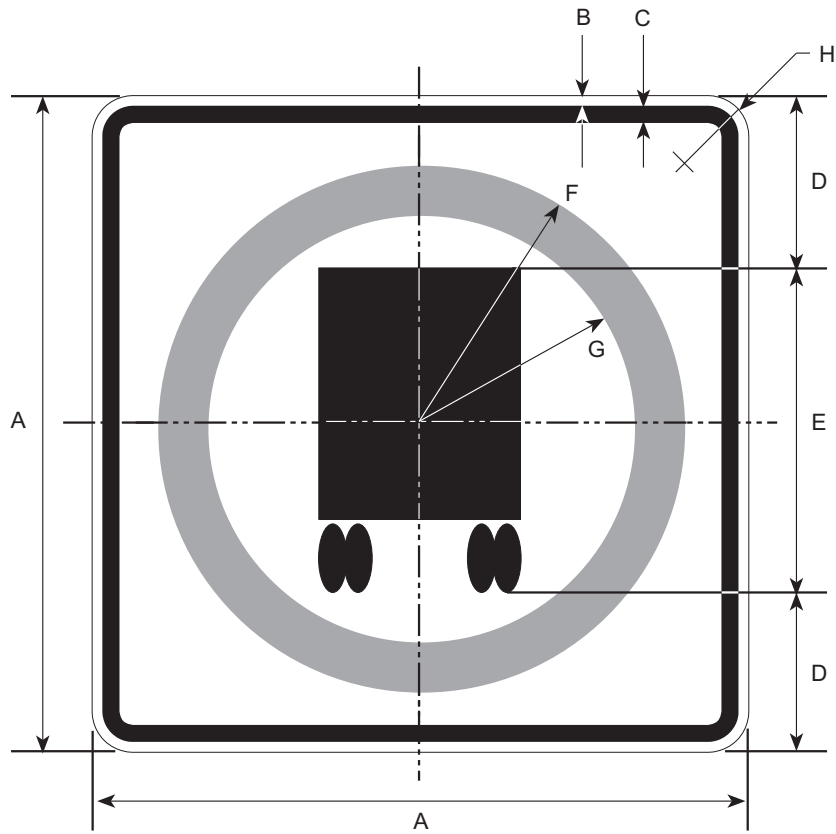

DIMENSIONS (MILLIMETERS)							
A	B	C	D	E	F	G	H
600	10	16	125	350	263	213	38
750	13	19	156	438	328	266	47
900	16	22	188	525	394	319	56
1200	19	31	250	700	525	425	75

DIMENSIONS (INCHES)							
A	B	C	D	E	F	G	H
24	3/8	5/8	5	14	10 1/2	8 1/2	1 1/2
30	1/2	3/4	6 1/4	17 1/2	13 1/8	10 5/8	1 7/8
36	5/8	7/8	7 1/2	21	15 3/4	12 3/4	2 1/4
48	3/4	1 1/4	10	28	21	17	3

COLORS

SYMBOL AND BORDER — BLACK (NON-REFL)
 BACKGROUND — WHITE (REFL)
 CIRCLE — GREEN (REFL)

S4-5 & S4-5A

5/06

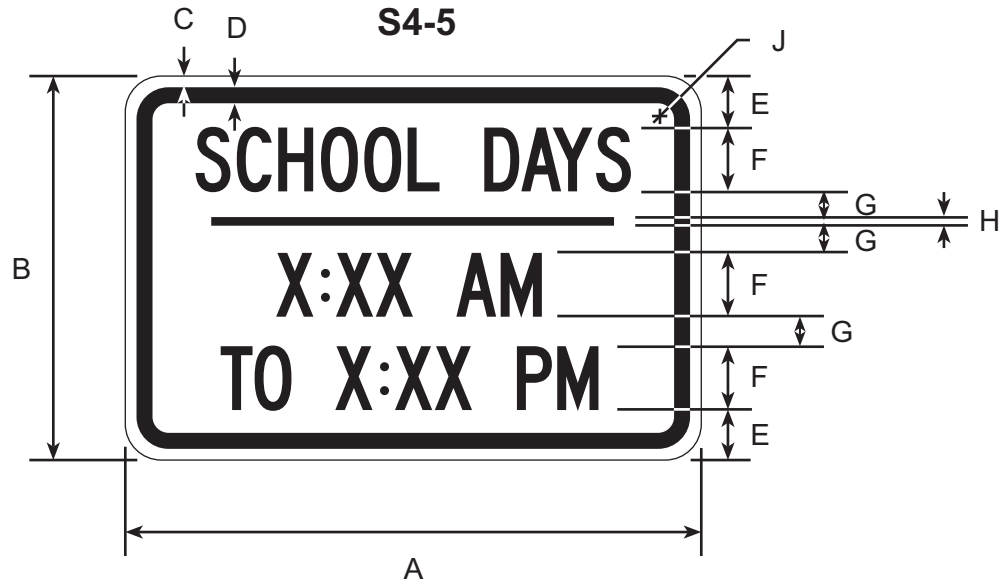

S4-5A

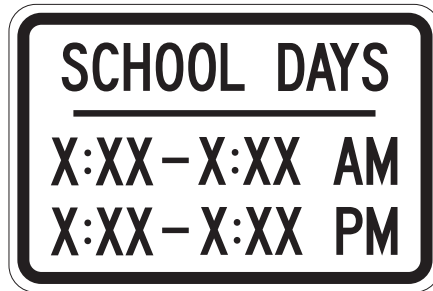

DIMENSIONS (MILLIMETERS)								
A	B	C	D	E	F	G	H	J
600	450	9	16	69	63C	38	16	38
900	600	16	22	81	100C	38	22	56

DIMENSIONS (INCHES)								
A	B	C	D	E	F	G	H	J
24	18	3/8	5/8	2 3/4	2 1/2C	1 1/2	5/8	1 1/2
36	24	5/8	7/8	3 1/4	4C	1 1/2	7/8	2 1/4

COLORS

LEGEND & BORDER - BLACK (NON-REFL)
BACKGROUND - WHITE (REFL)

W1-10L&R

4/06

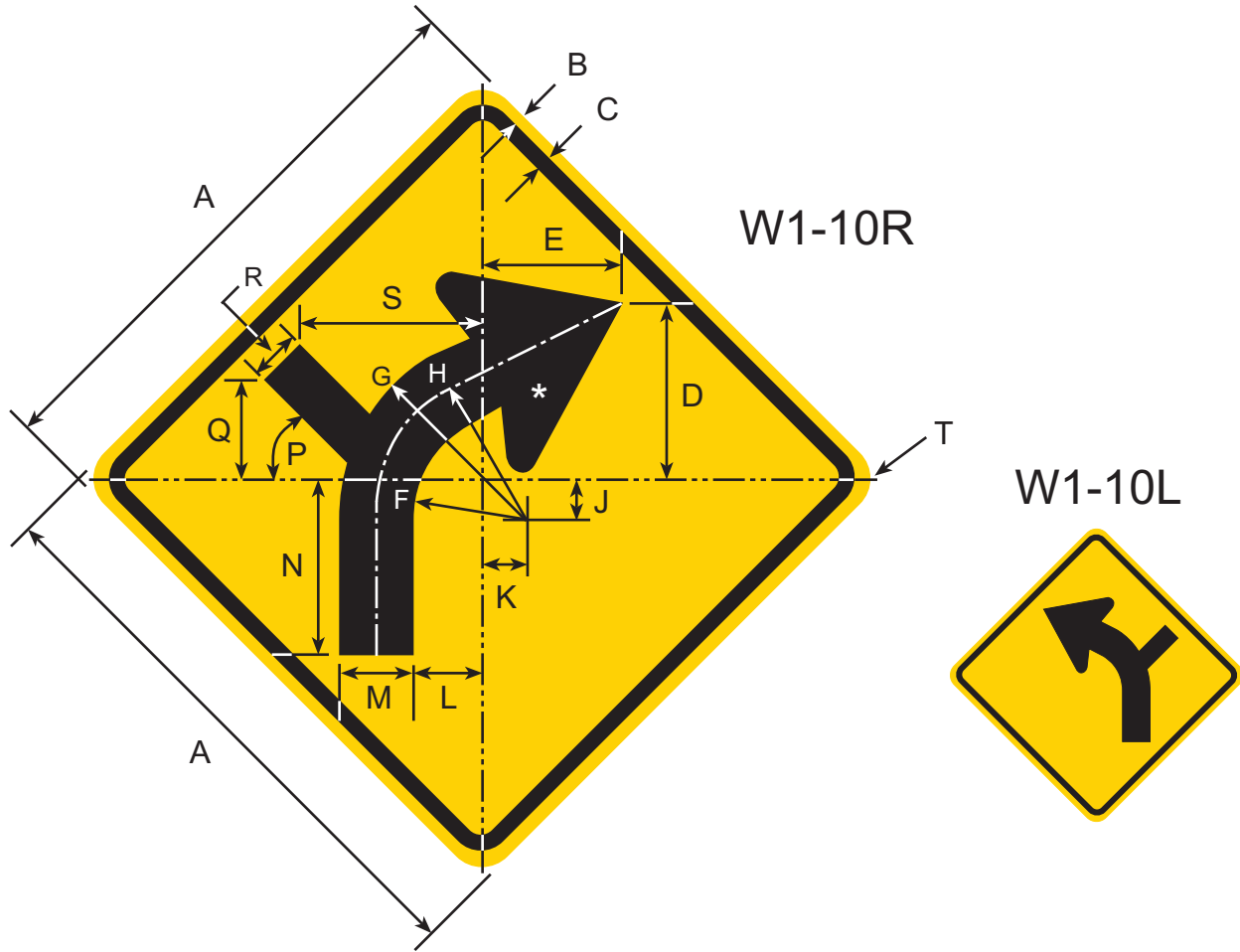

* SEE APPENDIX FOR STANDARD ARROW DETAILS

DIMENSIONS (INCHES)								
A	B	C	D	E	F	G	H	J
30	1/2	3/4	9 47/64	7 17/32	5 51/64	9 51/64	7 51/64	2 15/64
36	5/8	7/8	12 11/64	9 23/64	7 13/64	12 13/64	9 45/64	2 27/32
48	3/4	1 1/4	17	13 1/8	10	17	13 33/64	3 31/32

K	L	M	N	P	Q	R	S	T
2 11/64	3 31/64	4	9 23/32	45	5 11/64	2 39/64	9 39/64	1 7/8
2 59/64	4 23/64	5	12 11/64	45	6 13/64	3	11 17/32	2 1/4
4 5/64	6 5/64	7	17	45	8 9/32	4	15 3/8	3

COLORS

LEGEND, BORDER, & SYMBOL - BLACK (NON-REFL)
BACKGROUND - YELLOW (REFL)

W1-15

2/06

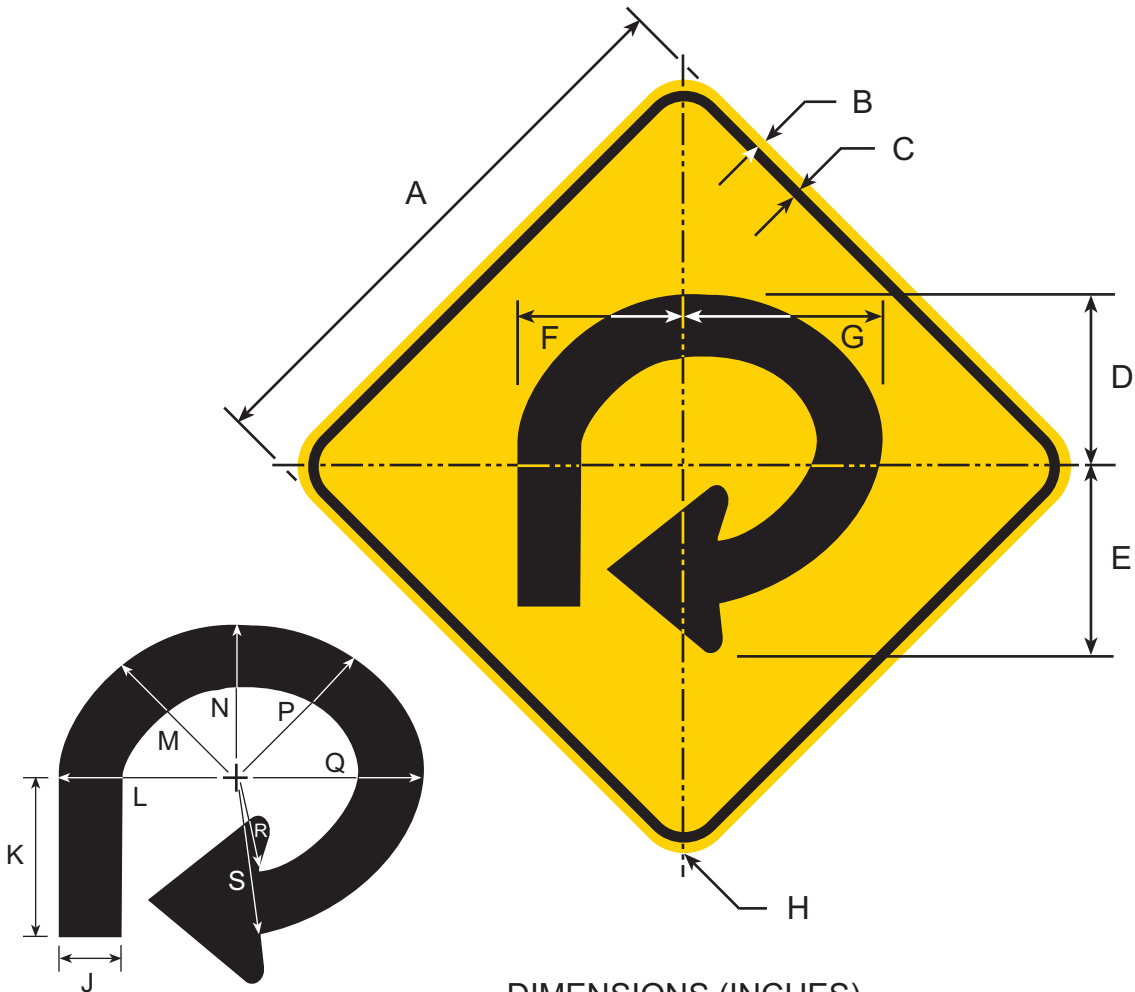

DIMENSIONS (INCHES)

A	B	C	D	E	F	G	H
30	1/2	3/4	9 9/32	10 5/32	8 19/32	10 5/16	1 7/8
36	5/8	7/8	11 1/8	12 7/32	10 5/16	12 13/32	2 1/4
48	3/4	1 1/4	14 27/32	16 1/4	13 3/4	16 17/32	3

J	K	L	M	N	P	Q	R	S
3 3/16	8 13/32	9 7/16	8 31/32	8 3/8	8 21/32	9 7/16	5 9/32	8 1/2
3 27/32	10 3/32	11 5/16	10 25/32	10 1/16	10 25/32	11 5/16	6 5/16	10 5/32
5 1/8	13 7/16	15 1/8	14 11/32	13 3/8	14 11/32	15 1/8	8 7/16	13 9/16

COLORS

LEGEND, BORDER, & SYMBOL - BLACK (NON-REFL)
 BACKGROUND - YELLOW (REFL)

W3-5

4/06

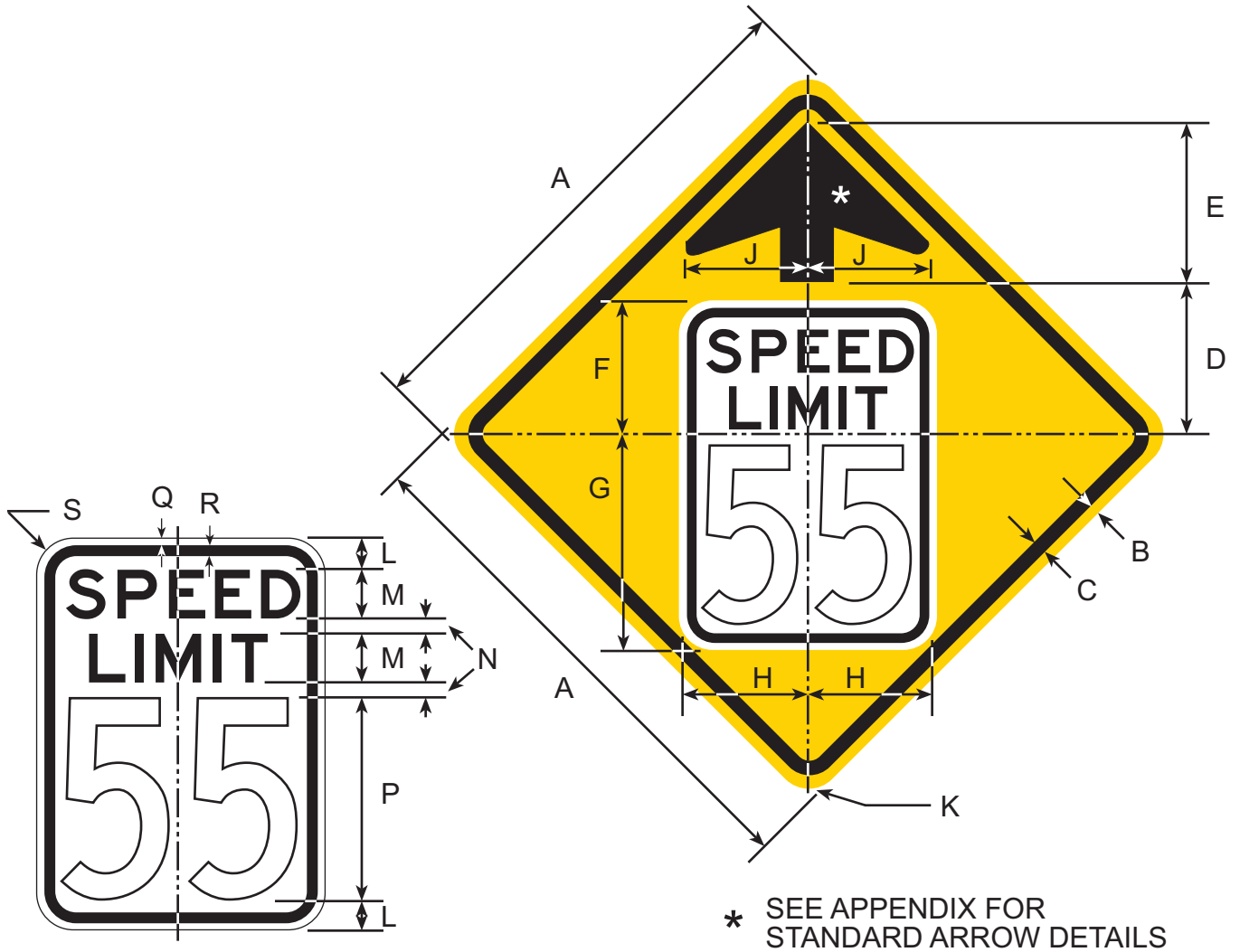

* SEE APPENDIX FOR STANDARD ARROW DETAILS

DIMENSIONS (INCHES)							
A	B	C	D	E	F	G	H
36	5/8	7/8	10	12	9	15	9
48	3/4	1 1/4	11 3/4	18	10 3/4	19 3/4	12

J	K	L	M	N	P	Q	R	S
9	2 1/4	2	3E	1	12C	3/8	5/8	2 1/4
12	3	2 1/4	4E	1 1/4	15C	3/8	5/8	3

COLORS

BORDER & ARROW - BLACK (NON-REFL)
 SYMBOL - See R2-1
 BACKGROUND - YELLOW (REFL)

W3-501

6/03

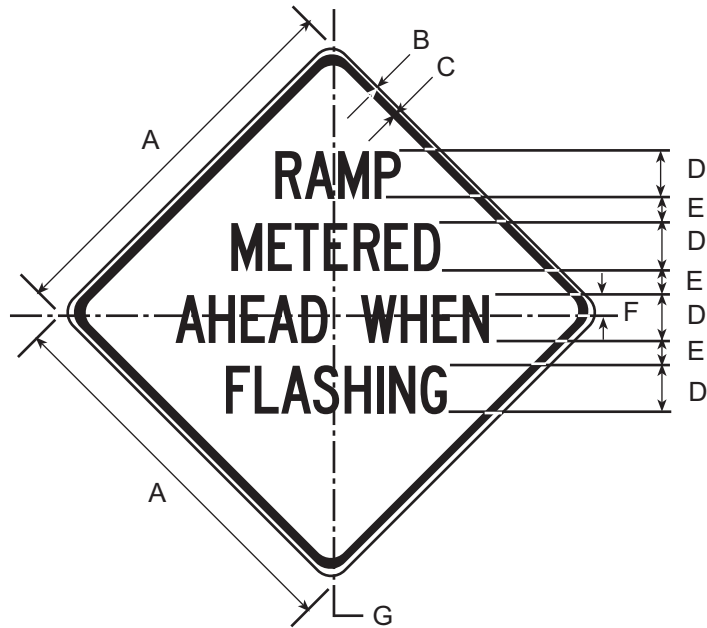

DIMENSIONS (MILLIMETERS)						
A	B	C	D	E	F	G
900	16	22	125C	50	25	56
1200	19	31	150C	100	19	75

DIMENSIONS (INCHES)						
A	B	C	D	E	F	G
36	5/8	7/8	5C	2	1	2 1/4
48	3/4	1 1/4	6C	4	3/4	3

COLORS

LEGEND - BLACK (NON-REFL)

BACKGROUND - YELLOW (REFL)

W4-1L & W4-1R

11/97

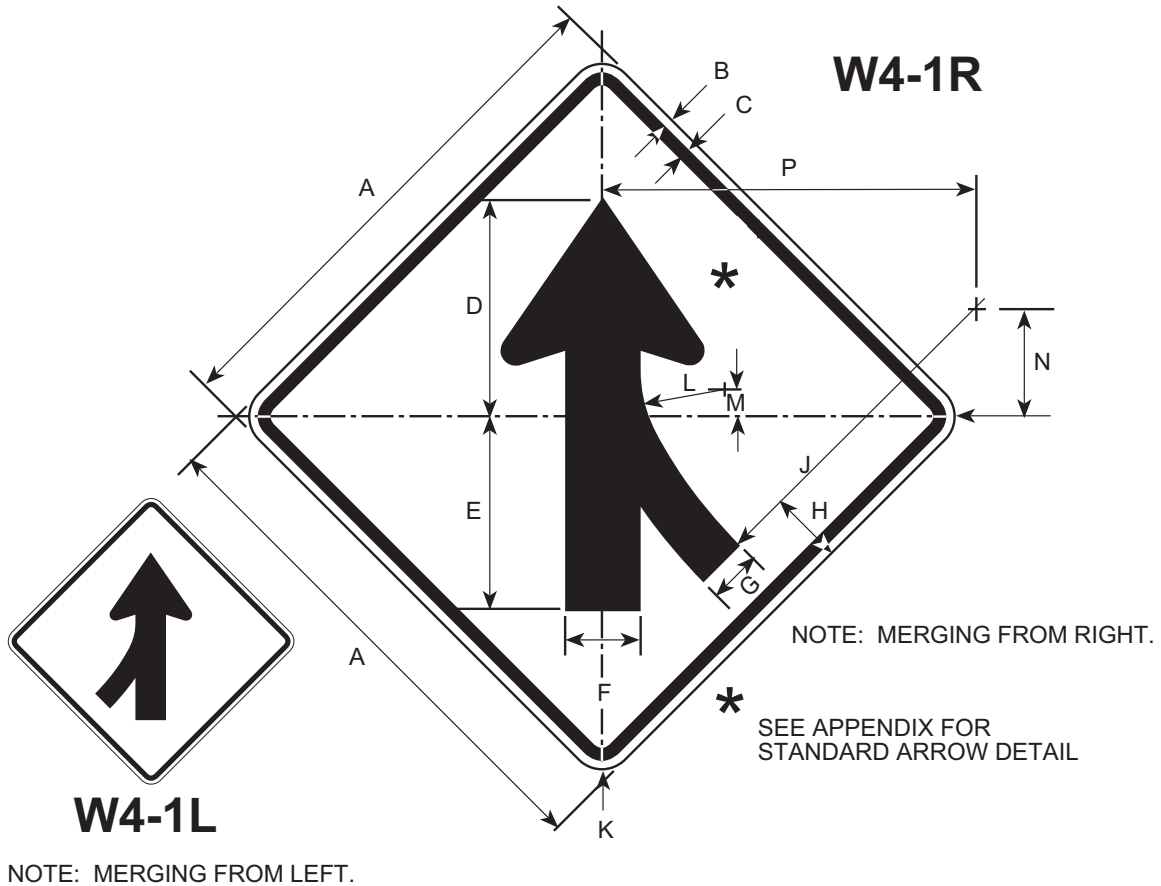

DIMENSIONS (MILLIMETERS)													
A	B	C	D	E	F	G	H	J	K	L	M	N	P
600	9	16	256	222	88	59	105	556	38	159	66	259	555
750	13	19	325	275	109	75	131	700	47	200	75	325	694
900	16	22	394	331	131	191	158	841	56	241	100	391	832
1200	19	31	513	438	175	11	209	112	75	567	131	522	110

DIMENSIONS (INCHES)													
A	B	C	D	E	F	G	H	J	K	L	M	N	P
24	3/8	5/8	10 1/4	8 3/4	3 1/2	2 3/8	4 3/16	22 1/4	1 1/2	6 3/8	2 5/8	10 3/8	22 3/16
30	1/2	3/4	13	1	4 3/8	3	4 1/2	28	1 7/8	8	3	13	27 3/4
36	5/8	7/8	15 3/4	13 1/4	5 1/4	3 5/8	5 5/8	33 5/8	2 1/4	9 5/8	4	15 5/8	35 5/16
48	3/4	1 1/4	20 1/2	17 1/2	7	4 3/4	6 3/4	45	3	12 13/16	5 1/4	20 3/4	44 3/8

COLORS

LEGEND — BLACK (NON-REFL)
BACKGROUND — YELLOW (REFL)

W4-2L & W4-2R

2/06

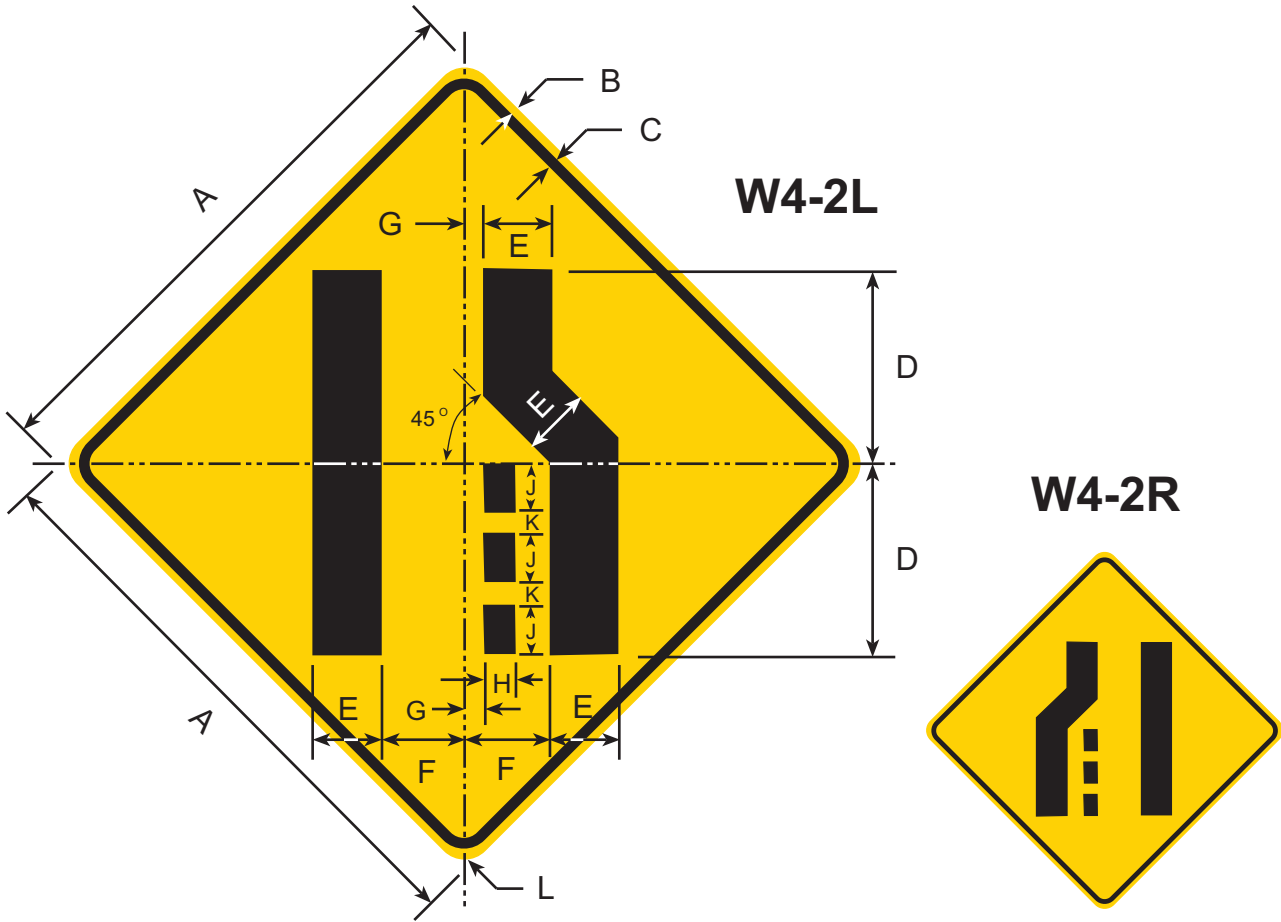

DIMENSIONS (MILLIMETERS)										
A	B	C	D	E	F	G	H	J	K	L
750	13	19	250	84	104	22	38	63	31	47
900	16	22	300	100	125	25	44	75	38	56
1200	19	31	400	134	167	31	59	100	50	75

DIMENSIONS (INCHES)										
A	B	C	D	E	F	G	H	J	K	L
30	1/2	3/4	10	3 3/8	4 3/16	7/8	1 1/2	2 1/2	1 1/4	1 7/8
36	5/8	7/8	12	4	5	1	1 3/4	3	1 1/2	2 1/4
48	3/4	1 1/4	16	5 3/8	6 11/16	1 1/4	2 3/8	4	2	3

COLORS

SYMBOL & BORDER — BLACK (NON-REFL)
 BACKGROUND — YELLOW (REFL)

W4-5

4/06

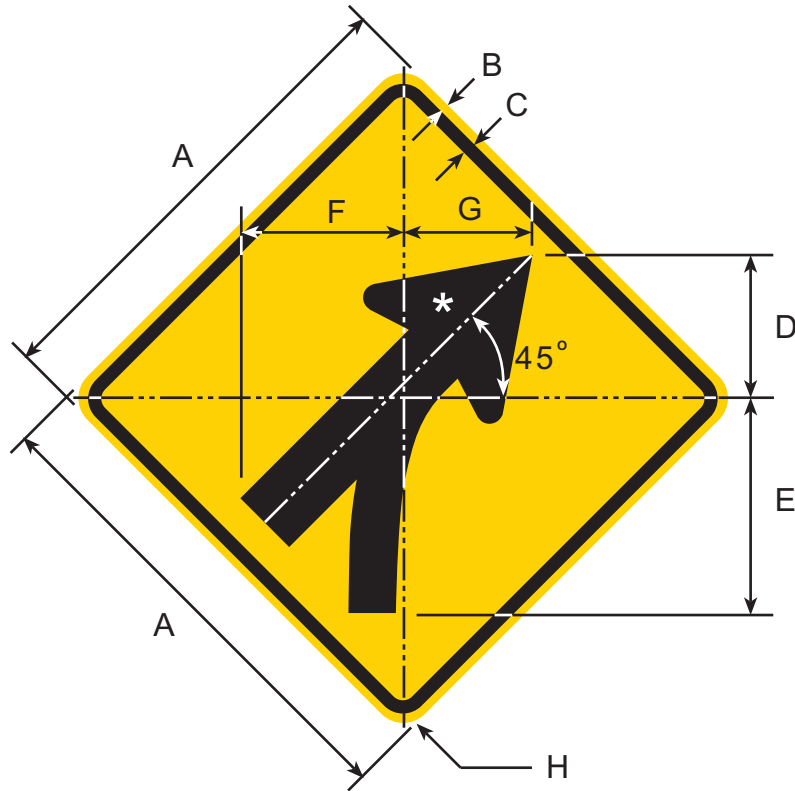

* SCALE AND ROTATE W4-1 SYMBOL TO FIT DIMENSIONS

DIMENSIONS (MILLIMETERS)							
A	B	C	D	E	F	G	H
750	13	19	229	344	261	204	47
900	16	22	273	413	314	245	56
1200	19	31	364	550	418	326	75

DIMENSIONS (INCHES)							
A	B	C	D	E	F	G	H
30	1/2	3/4	9 1/8	13 49/64	10 29/64	8 11/64	1 7/8
36	5/8	7/8	10 59/64	16 17/32	12 9/16	9 13/16	2 1/4
48	3/4	1 1/4	14 37/64	22	16 47/64	13 3/64	3

COLORS

SYMBOL & BORDER - BLACK (NON-REFL)
 BACKGROUND - YELLOW (REFL)

W4-6

4/06

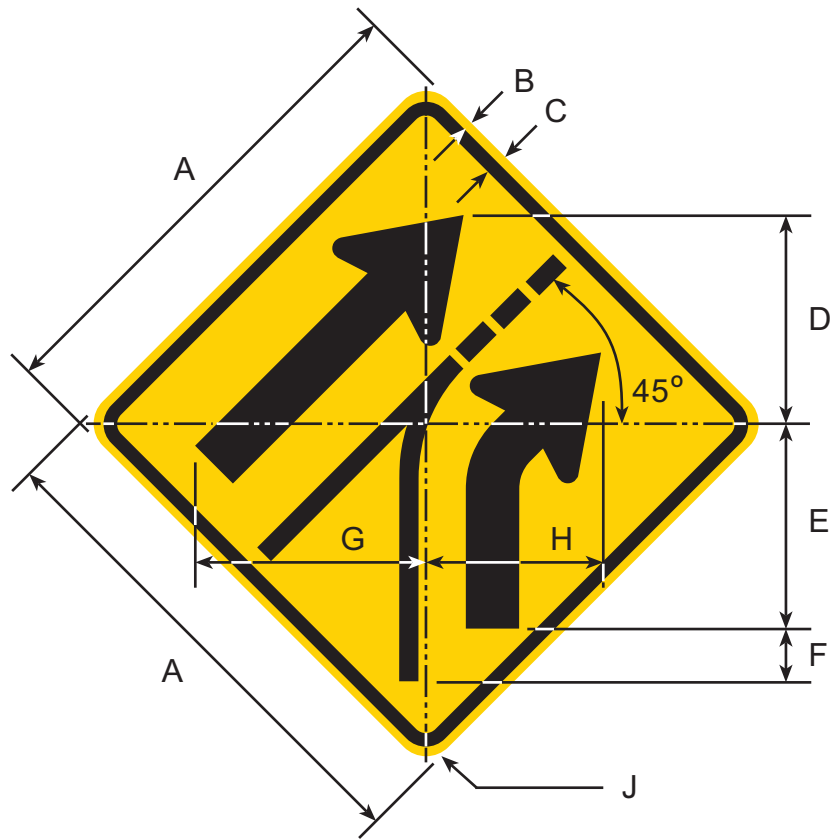

* SCALE AND ROTATE W4-3 SYMBOL TO FIT DIMENSIONS

DIMENSIONS (MILLIMETERS)								
A	B	C	D	E	F	G	H	J
750	13	19	324	335	59	364	281	47
900	16	22	389	402	70	437	336	56
1200	19	31	518	536	319	582	448	75

DIMENSIONS (INCHES)								
A	B	C	D	E	F	G	H	J
30	1/2	3/4	12 31/32	13 13/32	2 11/32	14 37/64	11 13/64	1 7/8
36	5/8	7/8	15 37/64	16 3/32	2 13/16	17 1/2	13 29/64	2 1/4
48	3/4	1 1/4	20 47/64	21 29/64	3 3/4	23 19/64	17 15/16	3

COLORS

SYMBOL & BORDER - BLACK (NON-REFL)
BACKGROUND - YELLOW (REFL)

W5-3

11/97

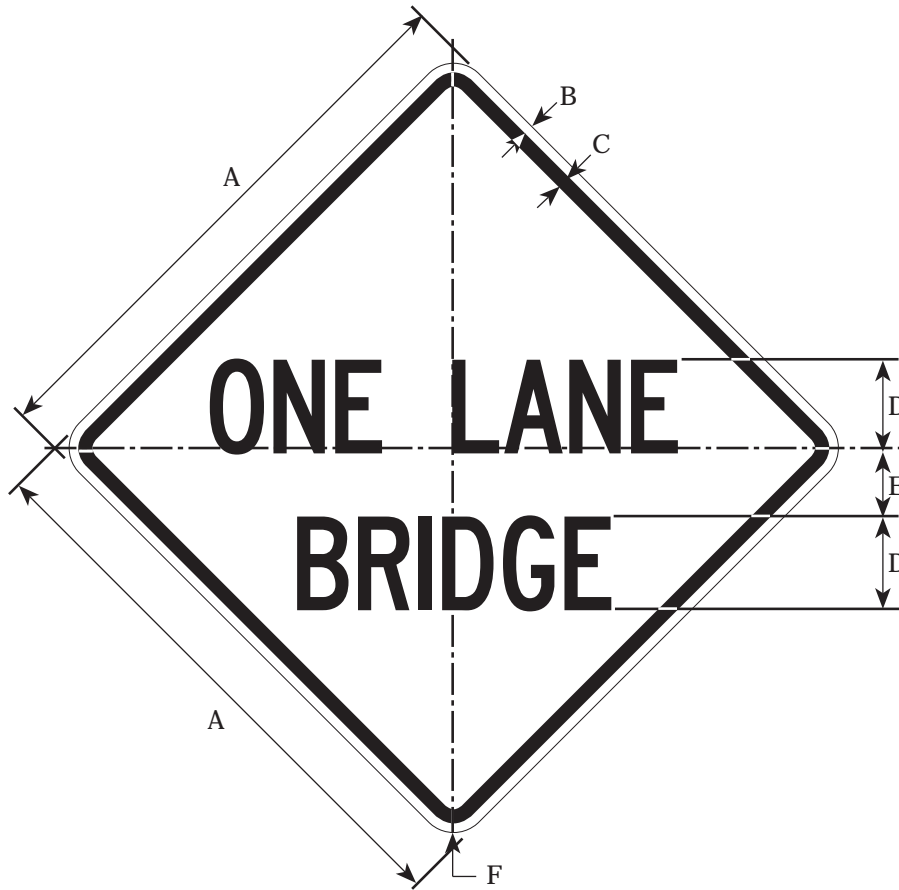

DIMENSIONS (MILLIMETERS)					
A	B	C	D	E	F
750	13	19	125C	84	47
900	16	22	150C	100	56
1200	19	31	200C	133	75

DIMENSIONS (INCHES)					
A	B	C	D	E	F
30	1/2	3/4	5C	3 1/4	1 7/8
36	5/8	7/8	6C	4	2 1/4
48	3/4	1 1/4	8C	5	3

COLORS

LEGEND - BLACK (NON-REFL)
 BACKGROUND - YELLOW (REFL)

W 7-4

4/06

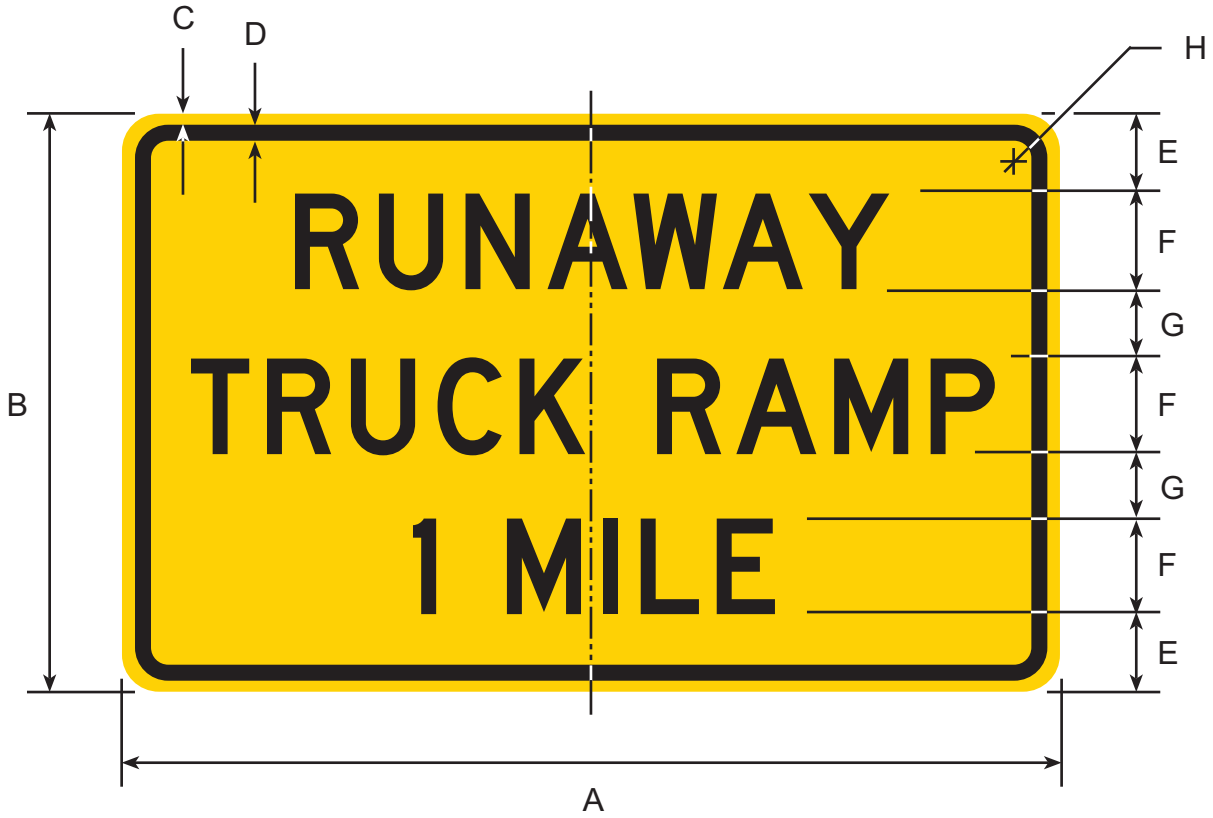

DIMENSIONS (MILLIMETERS)							
A	B	C	D	E	F	G	H
1950	1200	19	31	175	200D	125	75

DIMENSIONS (INCHES)							
A	B	C	D	E	F	G	H
78	48	3/4	1 1/4	7	8D	5	3

COLORS

LEGEND & BORDER - BLACK (NON-REFL)
 BACKGROUND - YELLOW (REFL)

W 7-4A

4/06

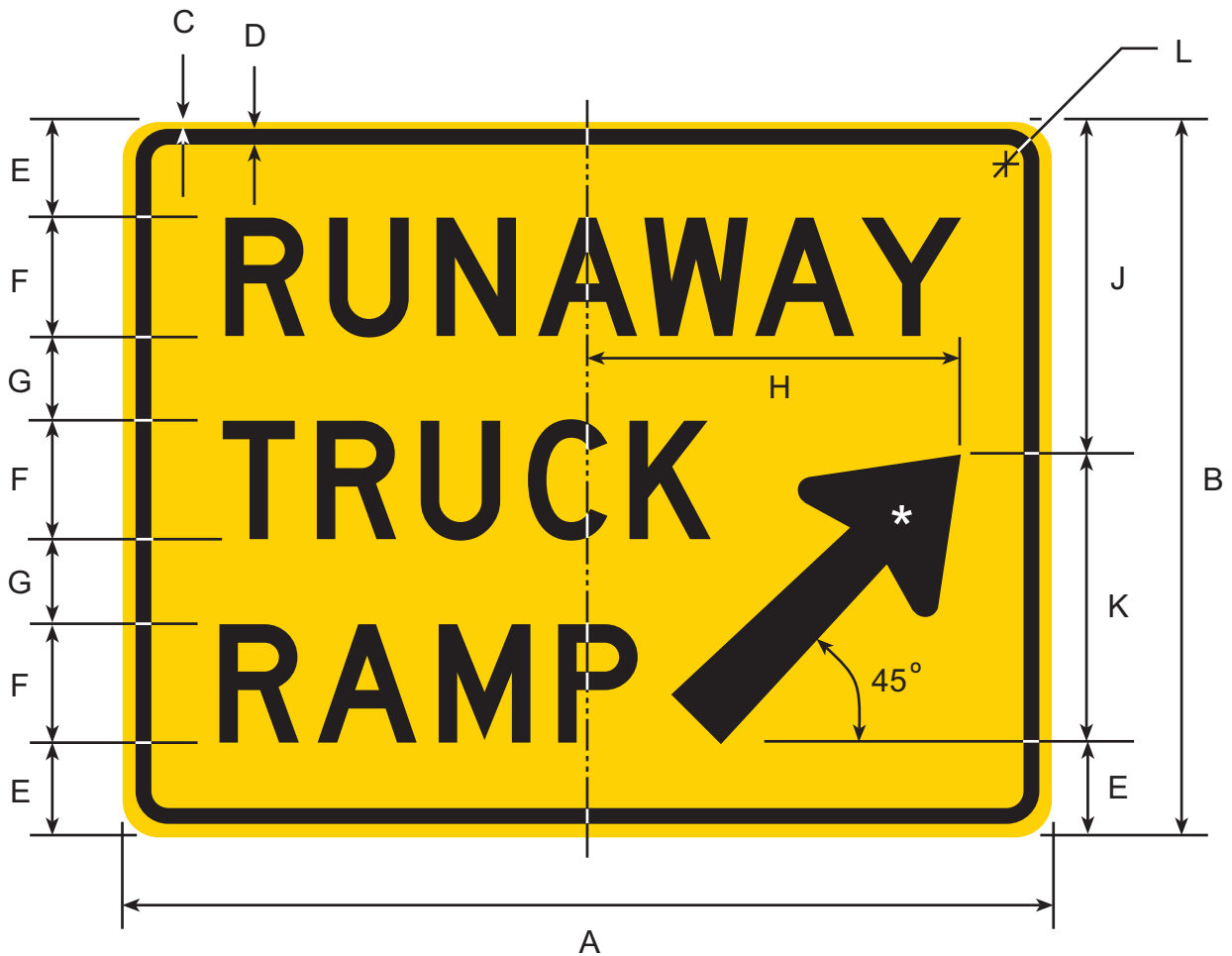

* SCALE AND ROTATE STANDARD ARROW (see appendix) TO FIT DIMENSIONS

DIMENSIONS (MILLIMETERS)										
A	B	C	D	E	F	G	H	J	K	L
1950	1200	19	31	175	200D	125	763	725	575	75

DIMENSIONS (INCHES)										
A	B	C	D	E	F	G	H	J	K	L
78	48	3/4	1 1/4	7	8D	5	30 1/2	29	23	3

COLORS

LEGEND, BORDER, & ARROW - BLACK (NON-REFL)
BACKGROUND - YELLOW (REFL)

W 7-4B

4/06

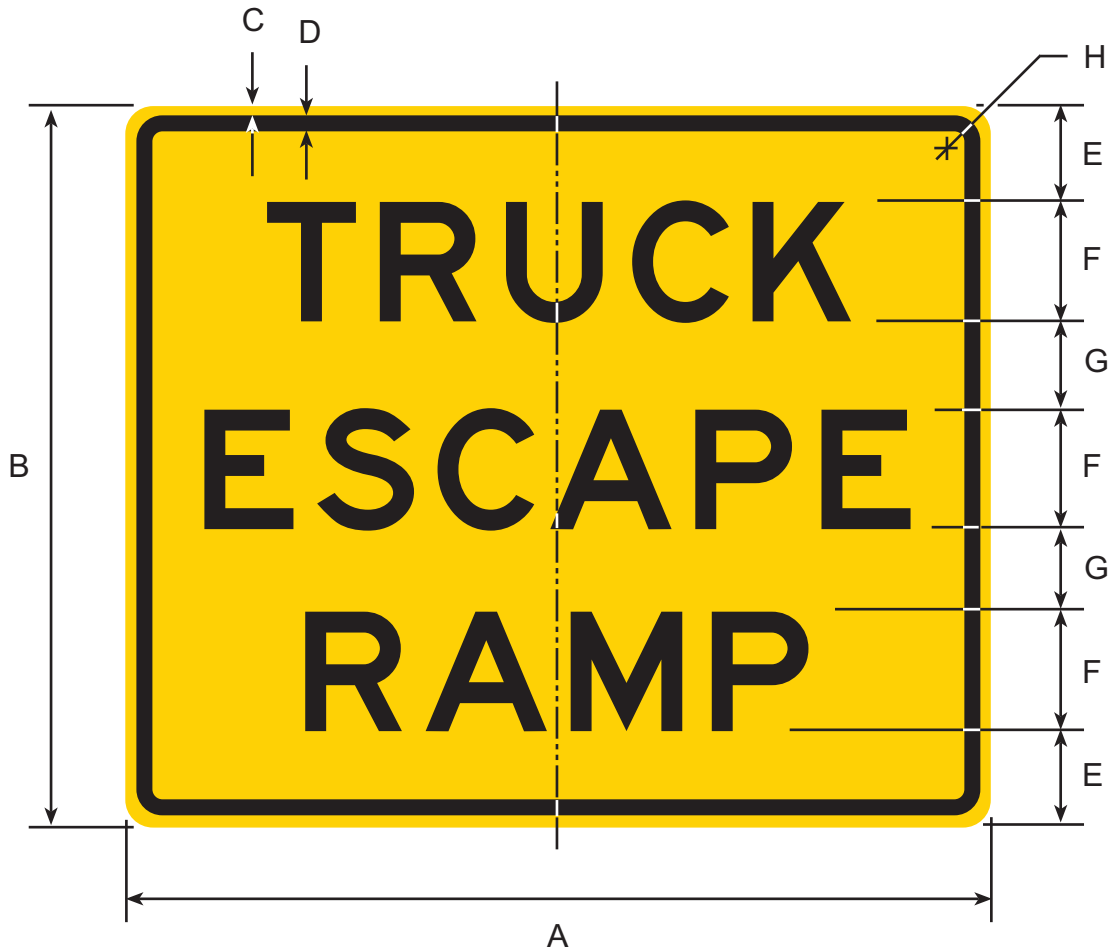

DIMENSIONS (MILLIMETERS)							
A	B	C	D	E	F	G	H
1800	1500	25	31	200	250E	175	75

DIMENSIONS (INCHES)							
A	B	C	D	E	F	G	H
72	60	1	1 1/4	8	10E	7	3

COLORS

LEGEND & BORDER - BLACK (NON-REFL)
 BACKGROUND - YELLOW (REFL)

W7-4C, W7-4D, & W7-4E

4/06

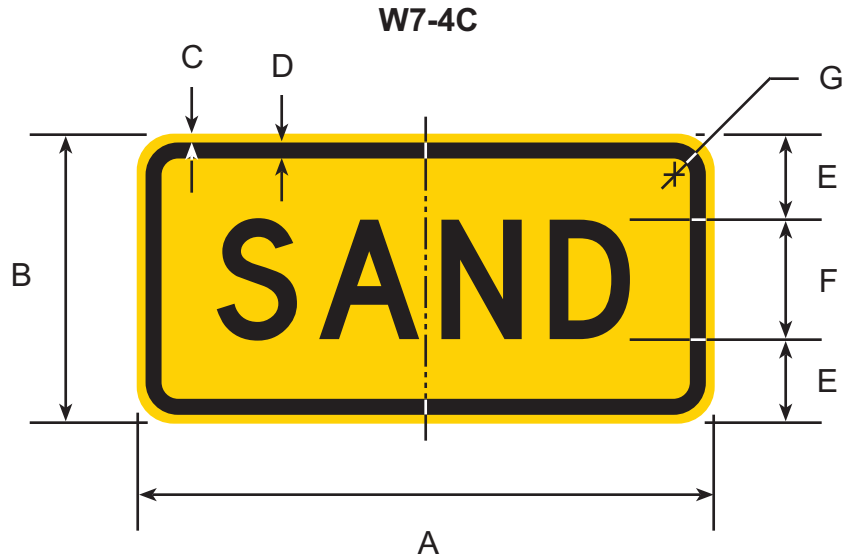

W7-4D*



W7-4E



* Use letter series C for GRAVEL message

DIMENSIONS (MILLIMETERS)						
A	B	C	D	E	F	G
600	300	9	16	88	125D	38

DIMENSIONS (INCHES)						
A	B	C	D	E	F	G
24	12	3/8	5/8	3 1/2	5C	1 1/2

COLORS

LEGEND & BORDER - BLACK (NON-REFL)
BACKGROUND - YELLOW (REFL)

W8-3

12/97

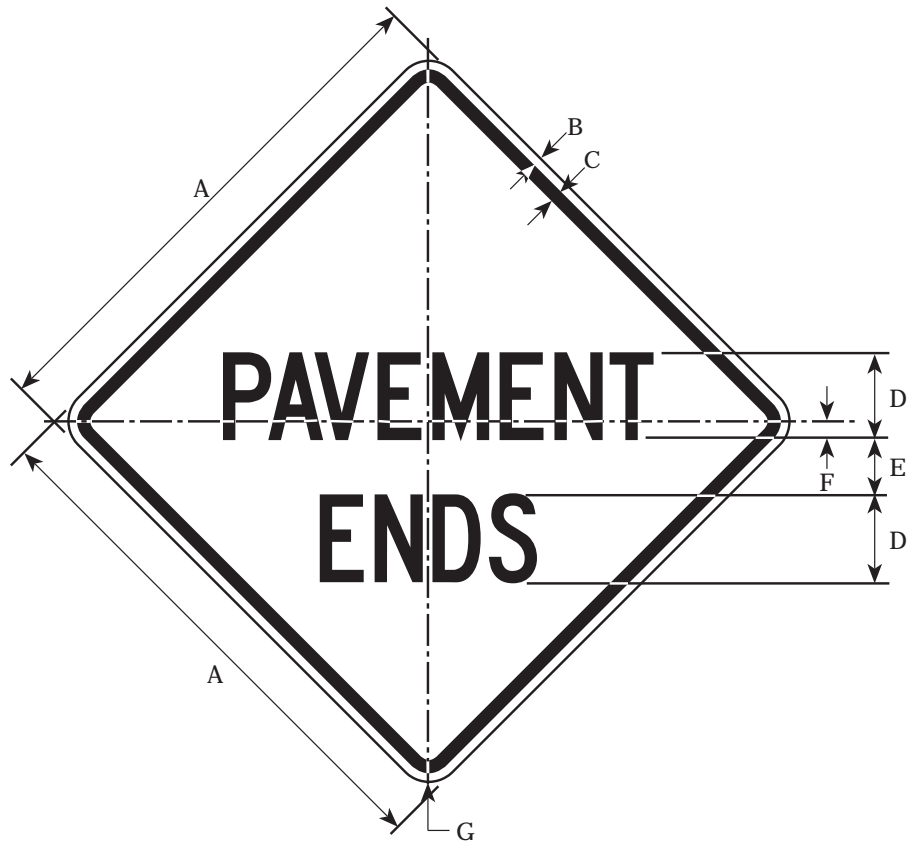

DIMENSIONS (MILLIMETERS)						
A	B	C	D	E	F	G
600	9	16	100C	56	13	38
750	12	19	125C	75	19	47
900	16	22	150C	88	25	56
1200	19	31	200C	11	47	75

DIMENSIONS (INCHES)						
A	B	C	D	E	F	G
18	3/8	5/8	4C	2 1/2	1/2	1 1/2
24	1/2	3/4	5C	3	3/4	1 7/8
36	5/8	7/8	6C	3 1/2	1	2 1/4
48	3/4	1 1/4	8C	4 1/2	1 1/2	3

COLORS

LEGEND - BLACK (NON-REFL)
BACKGROUND - YELLOW (REFL)

W10-1

4/99

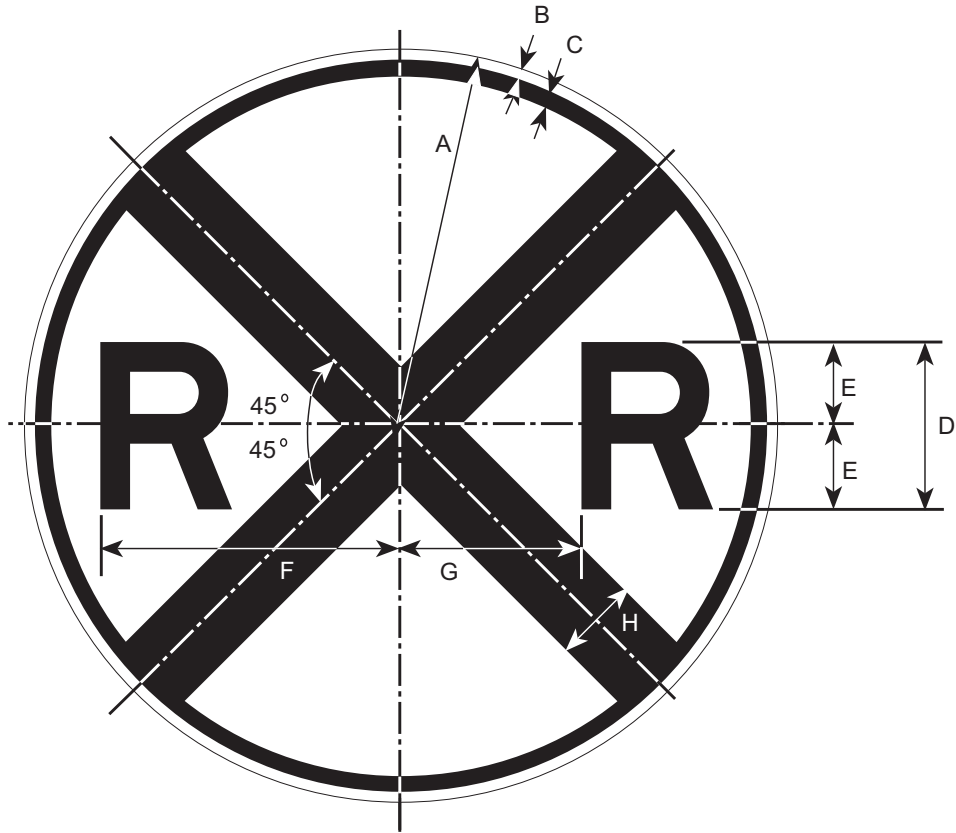

DIMENSIONS (MILLIMETERS)							
A	B	C	D	E	F	G	H
375	9	16	175E	88	309	178	75
450	13	19	200E	100	359	216	100
600	19	22	250E	125	459	297	125

DIMENSIONS (INCHES)							
A	B	C	D	E	F	G	H
15	3/8	5/8	7E	3 1/2	12 3/8	7 1/8	3
18	1/2	3/4	8E	4	14 3/8	8 5/8	4
24	3/4	1 1/4	10E	5	18 3/8	11	5

COLORS

LEGEND — BLACK (NON-REFL)
 BACKGROUND — YELLOW (REFL)

W10-1A

7/06

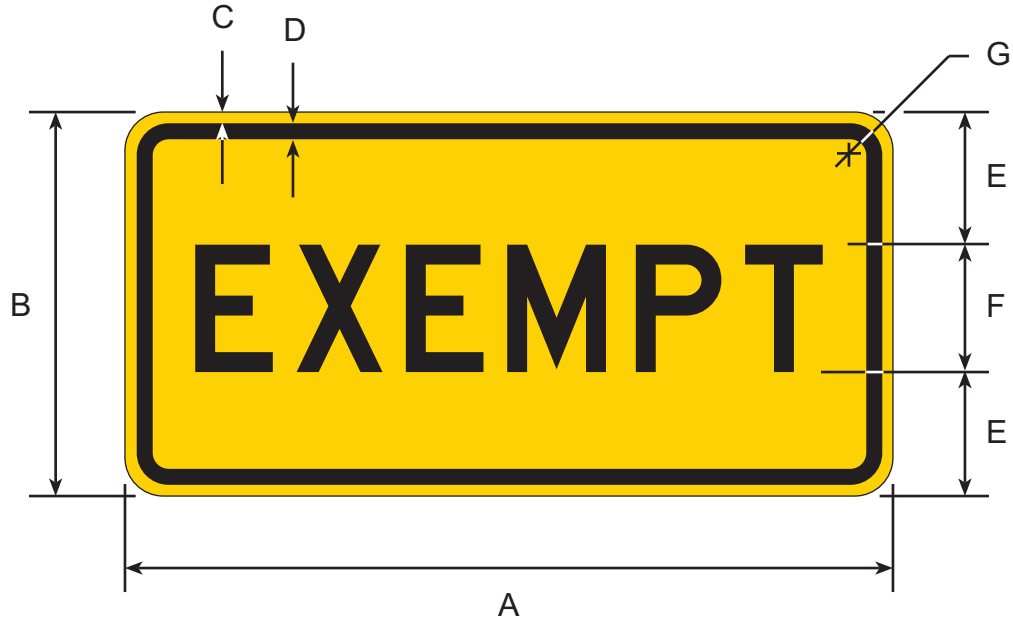

DIMENSIONS (MILLIMETERS)						
A	B	C	D	E	F	G
600	300	9	16	100	100D	38

DIMENSIONS (INCHES)						
A	B	C	D	E	F	G
24	12	3/8	5/8	4	4D	1 1/2

COLORS

LEGEND & BORDER - BLACK (NON-REFL)
BACKGROUND - YELLOW (REFL)

W10-101

11/97

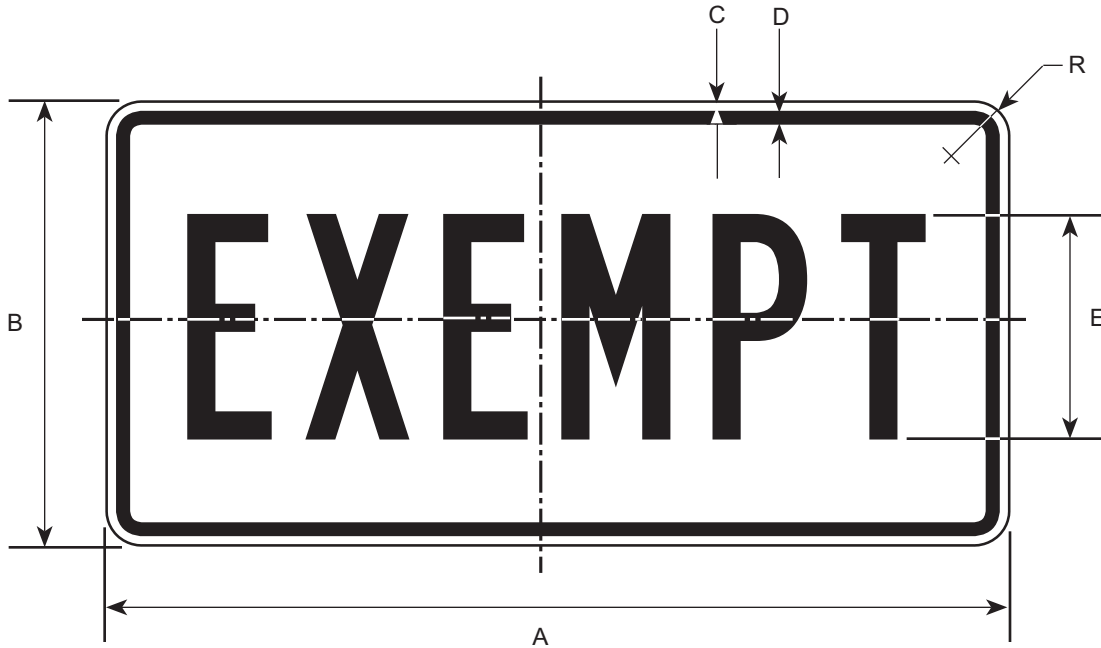

DIMENSIONS (MILLIMETERS)					
A	B	C	D	E	R
600	300	9	16	150-B	38
750	375	9	16	200-B	38

DIMENSIONS (INCHES)					
A	B	C	D	E	R
24	12	3/8	5/8	6-B	1 1/2
30	15	3/8	5/8	8-B	1 1/2

COLORS

LEGEND — BLACK (NON-REFL)
BACKGROUND — YELLOW (REFL)

W10-12

4/06

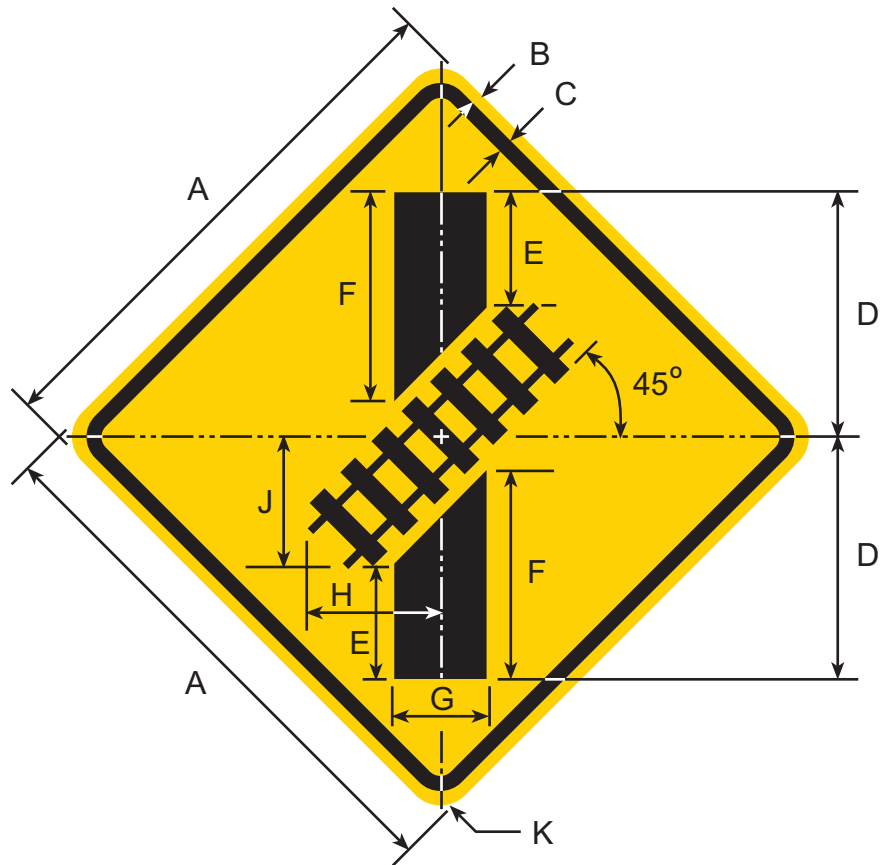

DIMENSIONS (MILLIMETERS)									
A	B	C	D	E	F	G	H	J	K
750	13	19	360	160	284	125	205	207	47
900	16	22	432	191	341	150	246	248	56
1200	19	31	577	254	454	200	328	331	75

DIMENSIONS (INCHES)									
A	B	C	D	E	F	G	H	J	K
30	1/2	3/4	14 13/32	6 3/8	11 3/8	5	8 13/64	8 9/32	1 7/8
36	5/8	7/8	17 9/32	7 41/64	13 21/32	6	9 27/32	9 59/64	2 1/4
48	3/4	1 1/4	23 1/16	10 11/64	18 11/64	8	13 1/8	13 1/4	3

COLORS

SYMBOL & BORDER - BLACK (NON-REFL)
 BACKGROUND - YELLOW (REFL)

W10-13

5/06

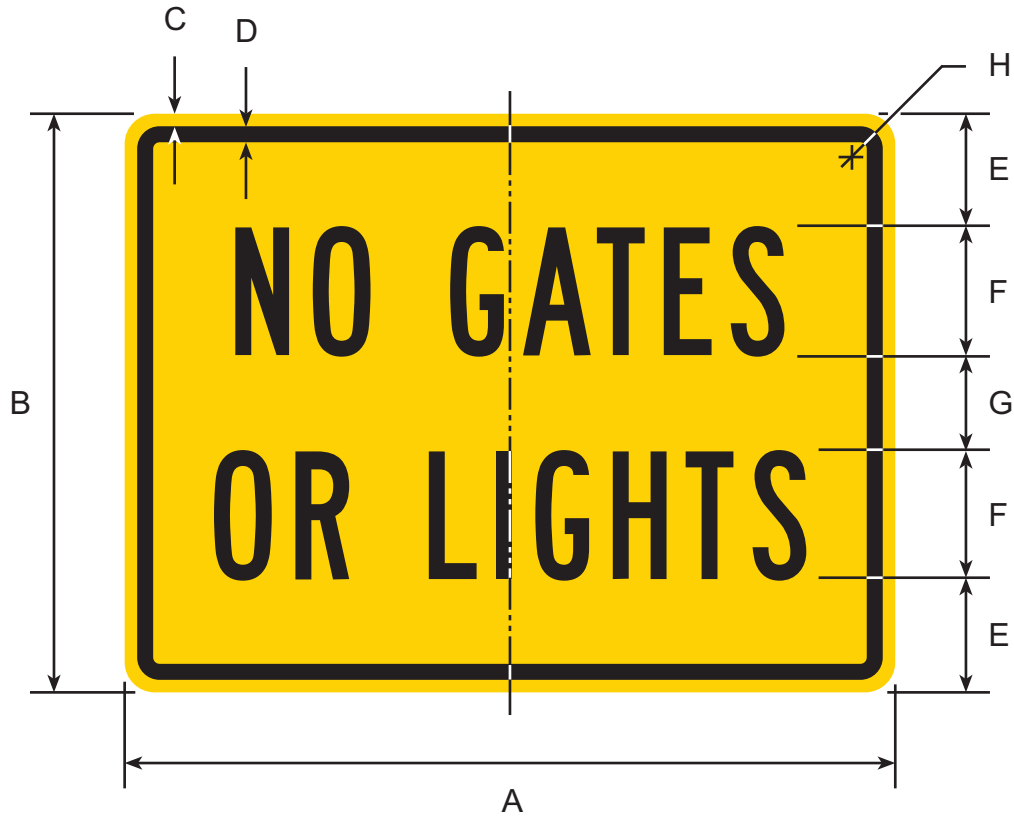

DIMENSIONS (MILLIMETERS)							
A	B	C	D	E	F	G	H
600	450	9	16	88	100B	75	38

DIMENSIONS (INCHES)							
A	B	C	D	E	F	G	H
24	18	3/8	5/8	3 1/2	4B	3	1 1/2

COLORS

LEGEND & BORDER - BLACK (NON-REFL)
 BACKGROUND - YELLOW (REFL)

W12-301

4/06

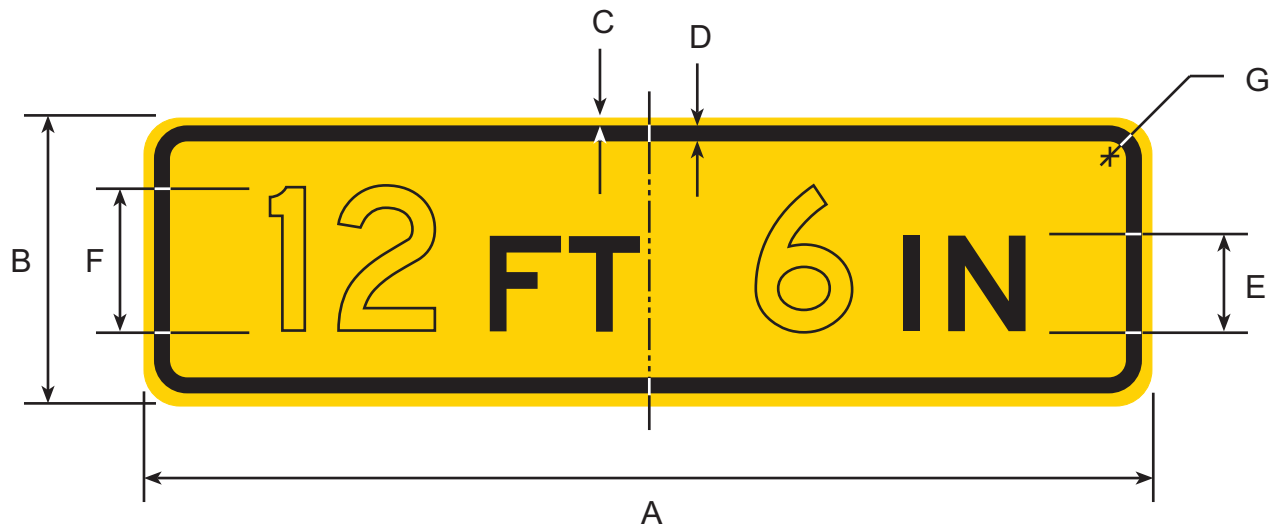

DIMENSIONS (MILLIMETERS)						
A	B	C	D	E	F	G
2100	600	19	31	200E	300E	75

DIMENSIONS (INCHES)						
A	B	C	D	E	F	G
84	24	3/4	1 1/4	8E	12E	3

COLORS

LEGEND & BORDER - BLACK (NON-REFL)
 BACKGROUND - YELLOW (REFL)

W12-302 L/R

11/97

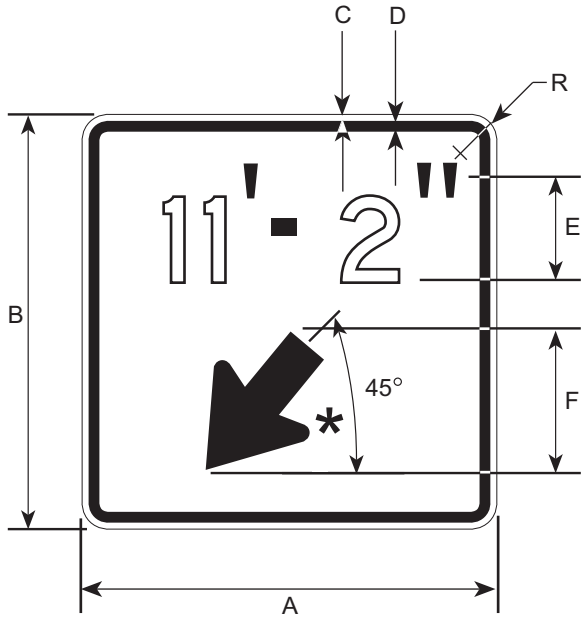

W12-302 L

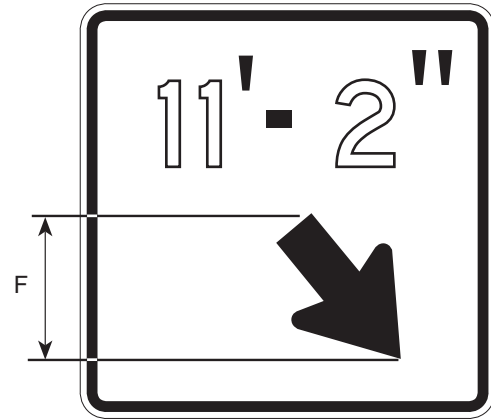

W12-302 R

* SEE APPENDIX FOR STANDARD ARROW

DIMENSIONS (MILLIMETERS)						
A	B	C	D	E	F	R
750	750	13	19	150-D	NO. 2	47
1200	1200	19	31	250-D	NO. 4	75

DIMENSIONS (INCHES)						
A	B	C	D	E	F	R
30	30	1/2	3/4	6-D	NO. 2	1 7/8
48	48	3/4	1 1/4	10-D	NO. 4	3

COLORS

LEGEND - BLACK (NON-REFL.)
BACKGROUND - YELLOW (REFL.)

W16-101 & W16-102

11/97

W16-101

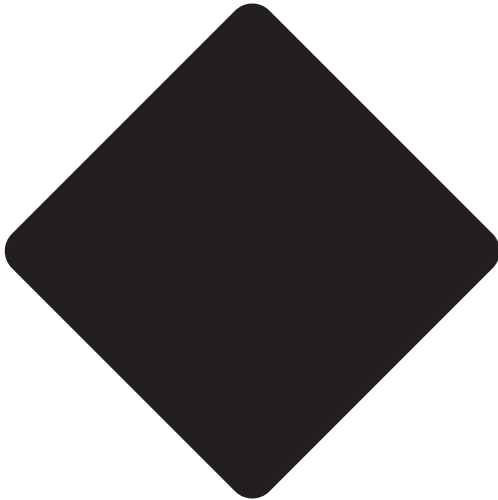

W16-102

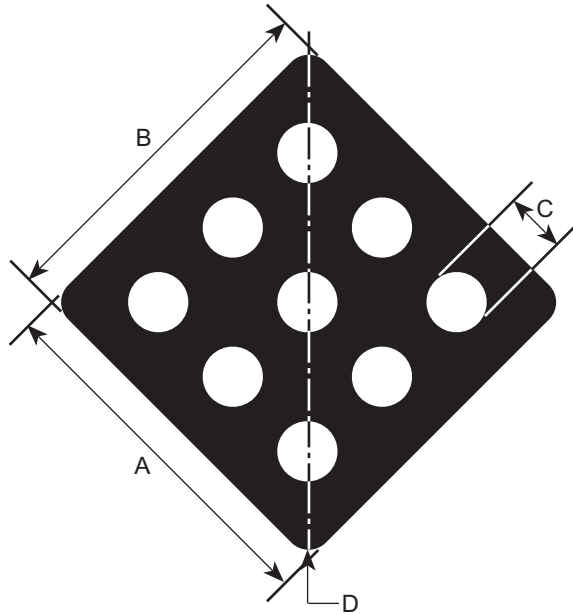

DIMENSIONS (MILLIMETERS)			
A	B	C	D
450	450	75	38

DIMENSIONS (INCHES)			
A	B	C	D
18	18	3	1 1/2

COLORS

W16-101— RED (REFL)
W16-102— RED OR BLACK (NON REFL)
WITH NINE 3" DIA. RED REFLECTORS

W16-5PR

6/03

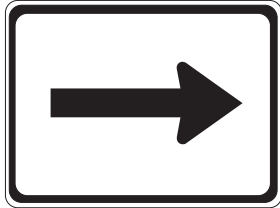

W16-5PL

6/03

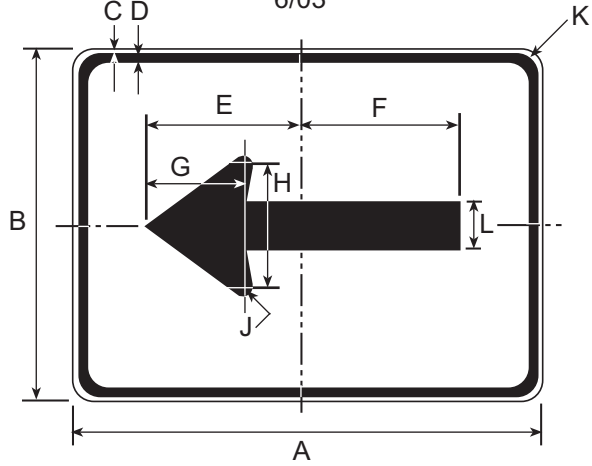

W16-6PR

6/03

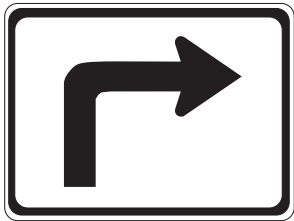

W16-6PL

6/03

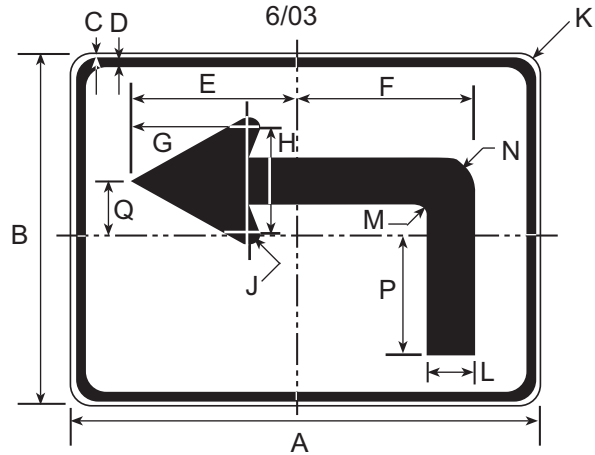

DIMENSIONS (MILLIMETERS)							
A	B	C	D	E	F	G	H
600	450	9	16	206	188	153	175

J	K	L	M	N	P	Q
14	38	75	19	25	148	72

DIMENSIONS (INCHES)							
A	B	C	D	E	F	G	H
24	18	3/8	5/8	8 1/4	7 1/2	6 1/8	7

J	K	L	M	N	P	Q
9/16	1 1/2	3	3/4	1	5 15/16	2 7/8

COLORS
 LEGEND - BLACK (NON-REFL)
 BACKGROUND - YELLOW (REFL)

W16-7PL & R

8/02

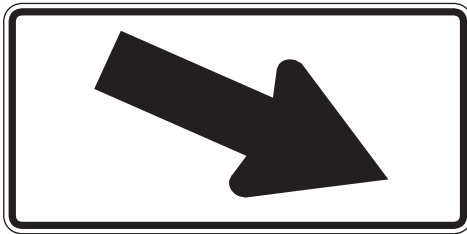
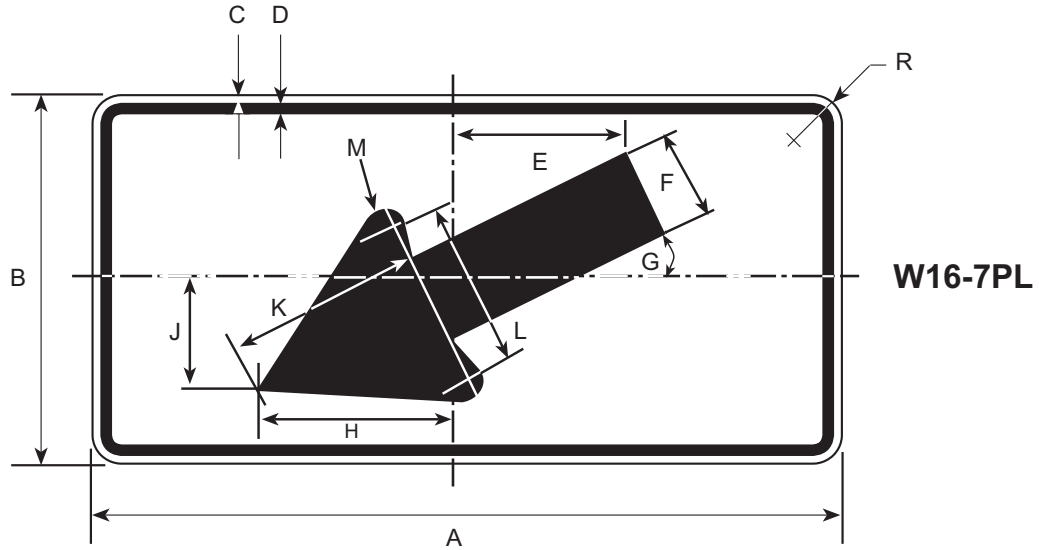

W16-7PR

NOTE: SIGN DESIGNERS SPECIFY SIGN COLOR

DIMENSIONS (MILLIMETERS)												
A	B	C	D	E	F	G	H	J	K	L	M	R
600	300	9	16	105	75	30°	147	81	147	173	14	38
750	450	13	19	163	113	30°	219	123	219	259	23	38

DIMENSIONS (INCHES)												
A	B	C	D	E	F	G	H	J	K	L	M	R
24	12	3/8	5/8	4 3/16	3	30°	5 7/8	3 1/4	5 7/8	6 15/16	9/16	1 1/2
30	18	1/2	3/4	6 1/2	4 1/2	30°	8 3/4	4 15/16	8 3/4	10 3/8	15/16	1 1/2

COLORS

LEGEND — BLACK (NON-REFL)
 BACKGROUND — YELLOW (REFL)
 OR FLUORESCENT
 YELLOW GREEN (REFL)

W16-9P

4/03

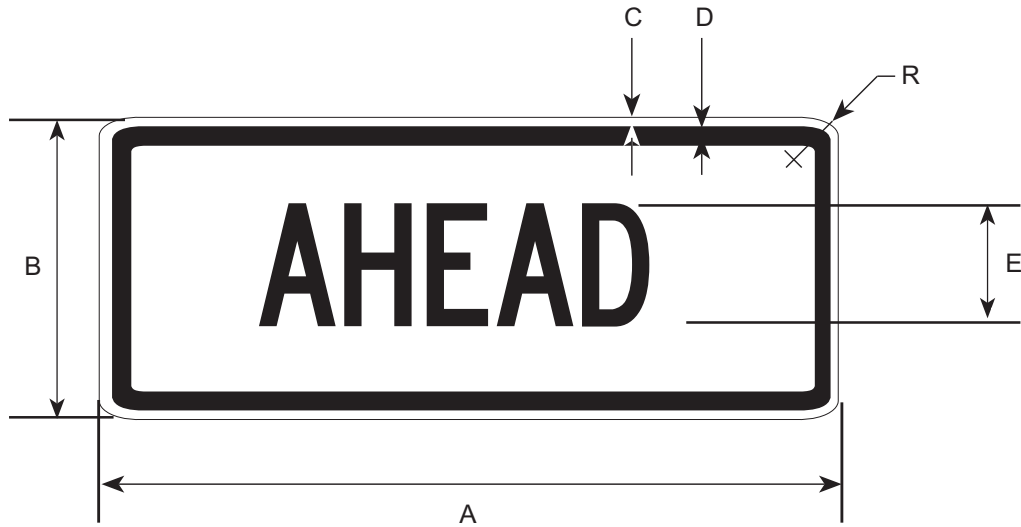

DIMENSIONS (MILLIMETERS)					
A	B	C	D	E	R
600	250	9	16	100-C	38
900	375	16	22	200-C	57
1200	500	19	31	300-C	75

DIMENSIONS (INCHES)					
A	B	C	D	E	R
24	10	3/8	5/8	4-C	1 1/2
36	15	5/8	7/8	8-C	2 1/4
48	20	3/4	1 1/4	10-C	3

COLORS

LEGEND — BLACK (NON-REFL)
 BACKGROUND — YELLOW (REFL)
 OR
 FLUORESCENT YELLOW GREEN (REFL)

W16-10

5/06

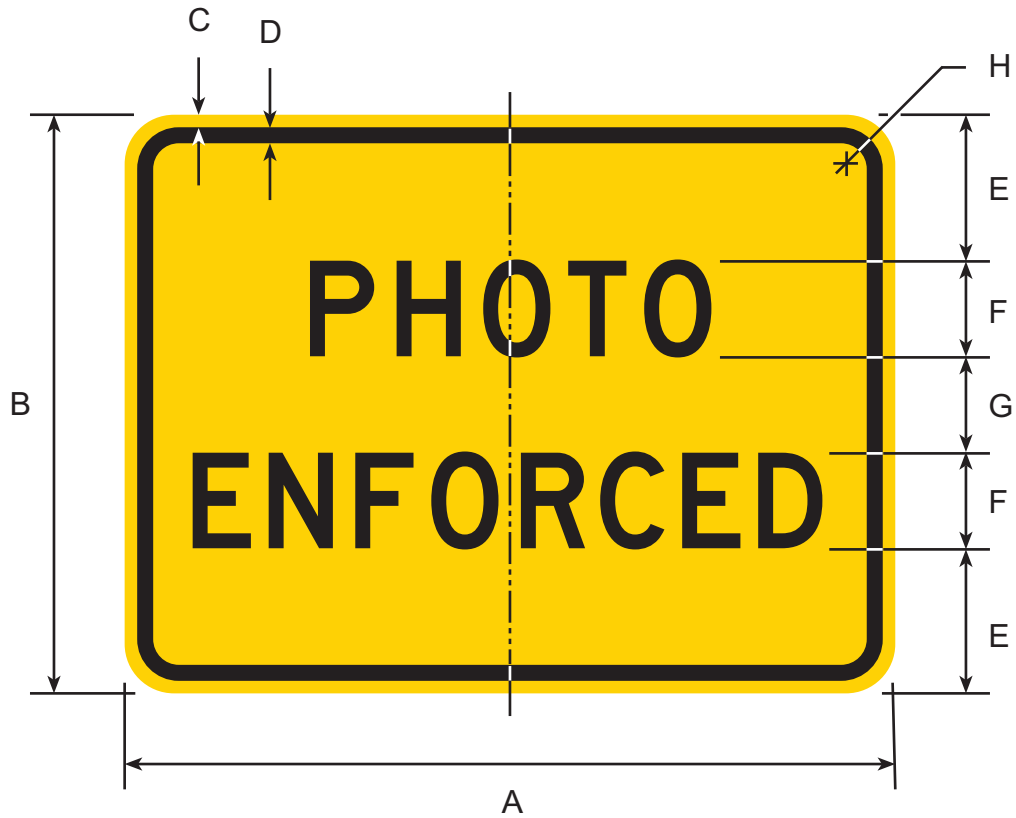

DIMENSIONS (MILLIMETERS)							
A	B	C	D	E	F	G	H
600	450	9	16	88	100B	75	38
900	600	16	22	150	100D	100	56
1200	900	19	31	175	150D	150	75

DIMENSIONS (INCHES)							
A	B	C	D	E	F	G	H
24	18	3/8	5/8	3 1/2	4B	3	1 1/2
36	24	5/8	7/8	6	4D	4	2 1/4
48	36	3/4	1 1/4	9	6D	6	3

COLORS

LEGEND & BORDER - BLACK (NON-REFL)
 BACKGROUND - YELLOW (REFL)

W21-1701

5/06

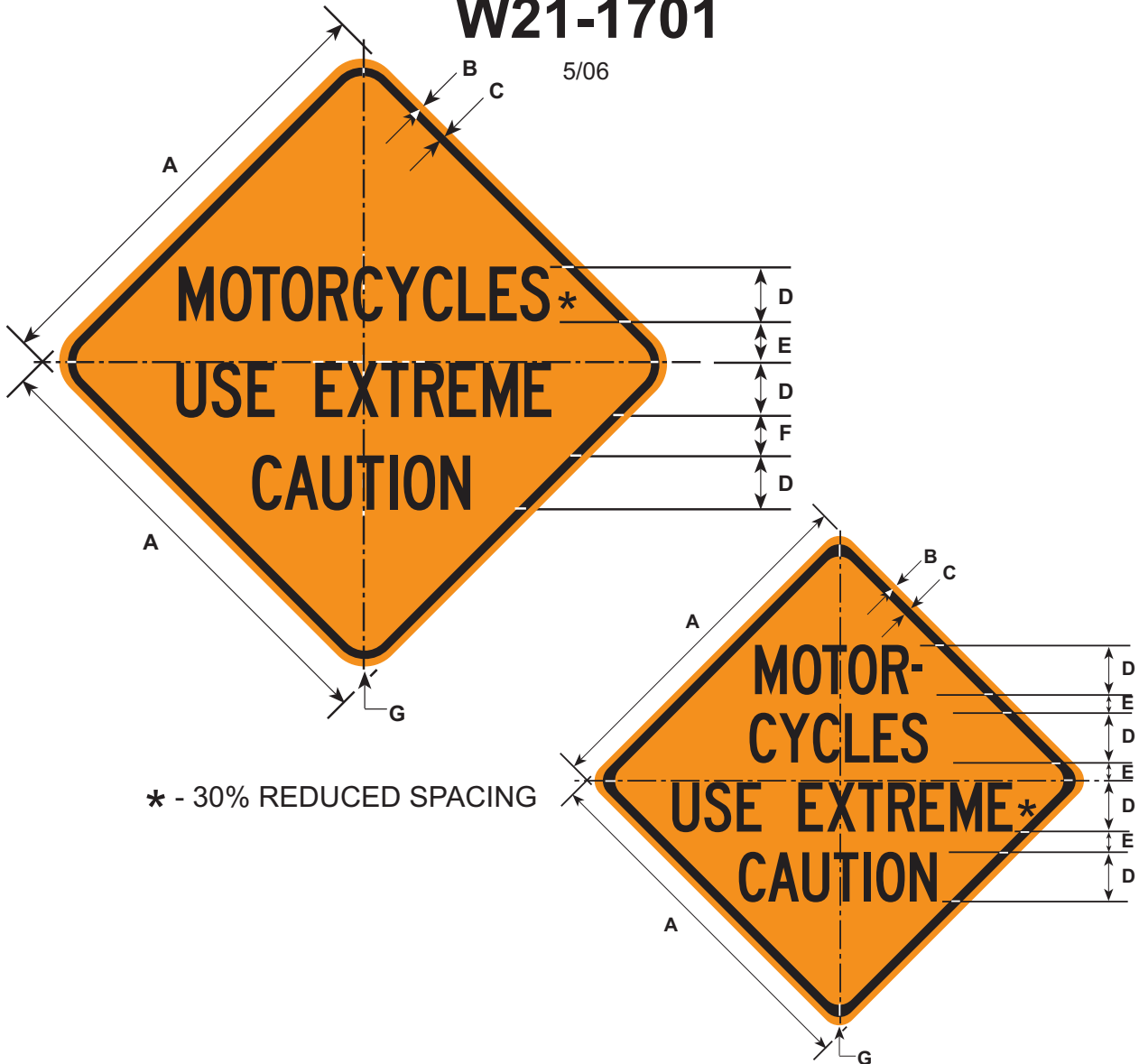

* - 30% REDUCED SPACING

DIMENSIONS (MILLIMETERS)						
A	B	C	D	E	F	G
900	16	22	125C	50	-	56
1200	19	31	150C	100	38	75

DIMENSIONS (INCHES)						
A	B	C	D	E	F	G
36	5/8	7/8	5C	2	-	2 1/4
48	3/4	1 1/4	6C	2 1/4	3 3/8	3

COLORS

LEGEND—BLACK (NON-REFL)
BACKGROUND—ORANGE (REFL)

APPENDIX A-7

6/06

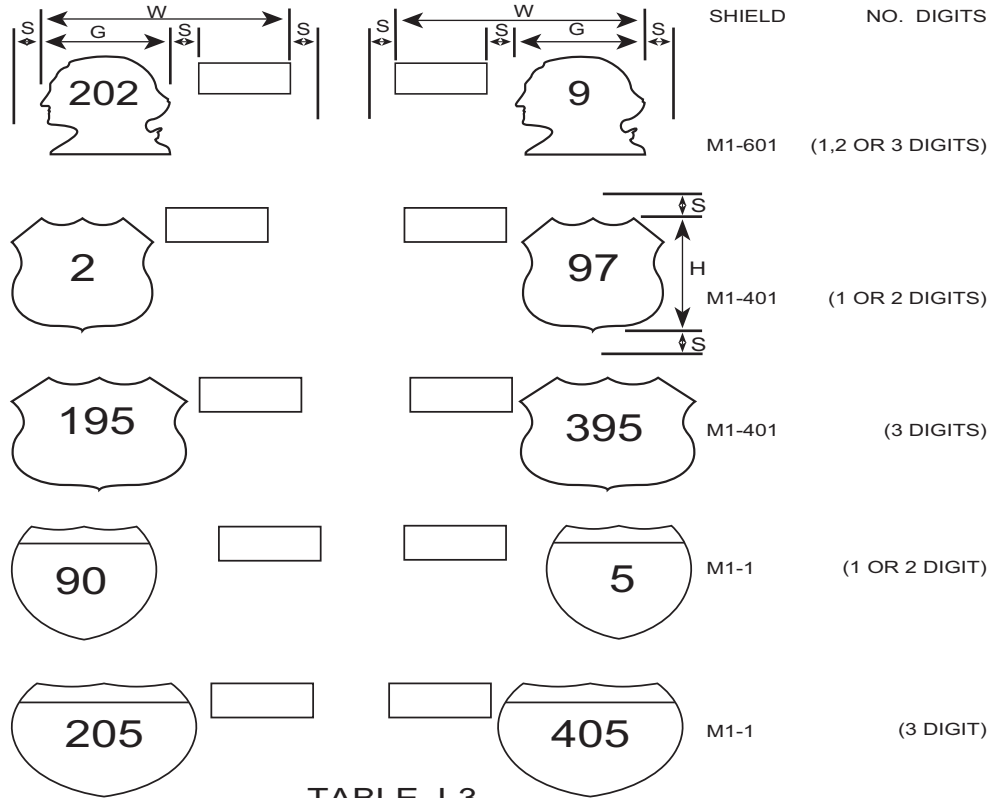

TABLE J-3

SHIELD CODE	SIZE CODE	SHIELD SIZE G X H	DIMENSIONS (MILLIMETERS) "W"							" S "
			NORTH	SOUTH	EAST	WEST	JCT	T		
M1-602	A	408 X 450	1300	1300	1150	1200	975	800	150	
	B	544 X 600	1775	1775	1575	1600	1300	1050	200	
	C	830 X 900	2325	2325	2100	2125	1725	1425	250	
	D OR E	830 X 900	2650	2650	2375	2400	1925	1575	300	
M1-1 M1-401	A	450 X 450	1375	1375	1225	1250	1050	875	150	
	A	563 X 450	1500	1500	1350	1375	117	1000	150	
	B	600 X 600	1825	1825	1625	1650	1400	115	200	
	B	750 X 600	1975	1975	1775	1800	1550	1300	200	
	C	900 X 900	2425	2425	2175	2200	1900	1600	250	
	C	1125 X 900	2650	2650	2400	2425	2125	1825	250	
	D OR E	900 X 900	2750	2750	2425	2475	2100	1750	300	
	D OR E	1125 X 900	2975	2975	2650	2700	2325	1975	300	

SHIELD CODE	SIZE CODE	SHIELD SIZE G X H	DIMENSIONS (INCHES) "W"							" S "
			NORTH	SOUTH	EAST	WEST	JCT	TO		
M1-602	A	16 5/16 X 18	52	52	46	48	39	32	6	
	B	21 3/4 X 24	71	71	63	64	52	42	8	
	C	33 3/16 X 36	93	93	84	85	69	57	10	
	D OR E	33 3/16 X 36	106	106	95	96	77	63	12	
M1-1 M1-401	A	18 X 18	55	55	49	50	42	35	6	
	A	22 1/2 X 18	60	60	54	55	47	40	6	
	B	24 X 24	73	73	65	66	56	46	8	
	B	30 X 24	79	79	71	72	62	52	8	
	C	36 X 36	97	97	87	88	76	64	10	
	C	45 X 36	106	106	96	97	85	73	10	
	D OR E	36 X 36	110	110	97	99	84	70	12	
	D OR E	45 X 36	119	119	106	108	93	79	12	

APPENDIX A-8

10/03

Exit Gore Widths.

Table J-5 illustrates four possible sign layouts for exit gore signs on the Interstate system or where exit numbers are to be provided. The first layout is the most common and is used where there is a single exit within that milepost. The second layout is used where there are multiple exits within that milepost.

The third and fourth layouts are reserved for those extremely narrow gore areas where it is impossible to install the first two configurations. These signs will be treated as the exception and are included herewith only to make the designer aware of this layout.

The dimensions indicated are the actual sign width upon which the 12"/15" legend is installed.

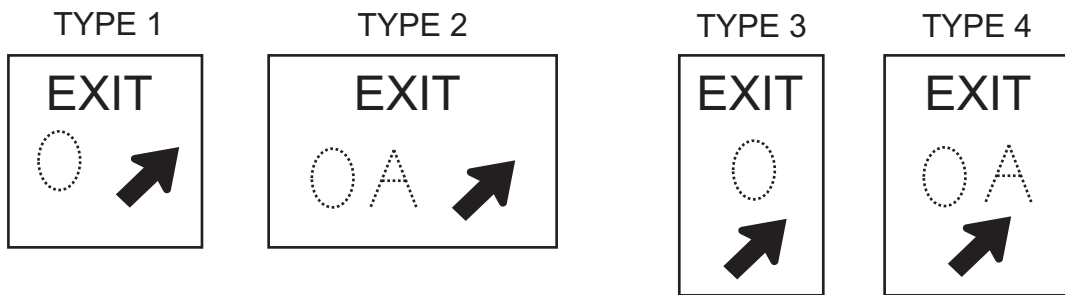

	SIGN WIDTH feet								
Numeral Shape	1	0	1	10	00	11	11	100	000
TYPE 1	5	5	5	5.5	6	6	6.5	7	7
TYPE 2	5.5	6	6.5	7	7.5	7.5	8	8.5	9
TYPE 3	4	4	4	4	4	4	4	4.5	5
TYPE 4	4	4	4	4.5	5	5	5.5	6	6.5

TABLE J-5

	SIGN WIDTH mm								
Numeral Shape	1	0	1	10	00	11	11	100	000
TYPE 1	1500	1500	1500	1650	1800	1800	1950	2100	2100
TYPE 2	1650	1800	1950	2100	2250	2250	2400	2550	2700
TYPE 3	1200	1200	1200	1200	1200	1200	1200	1350	1500
TYPE 4	1200	1200	1200	1350	1500	1500	1650	1800	1950

B-1(for W7-4B)

5/06

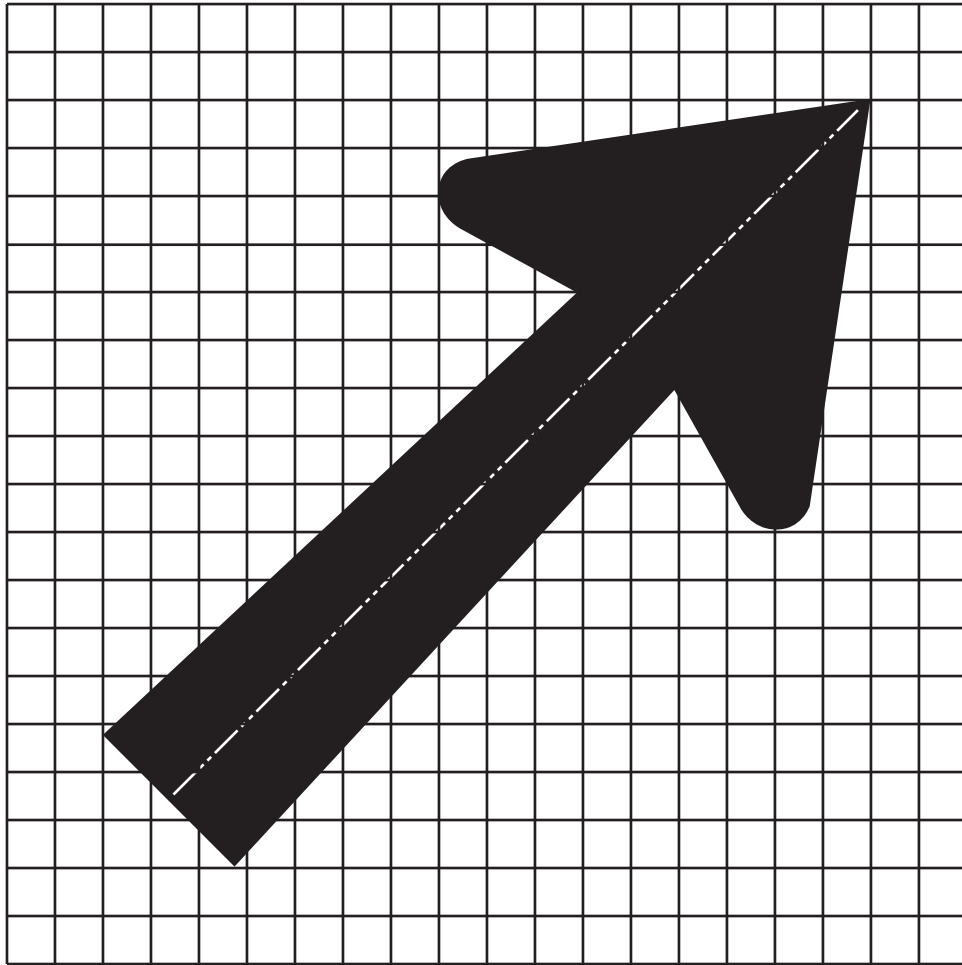

APPENDIX B-4A

5/06

STANDARD 6" X 9" ARROW DETAILS

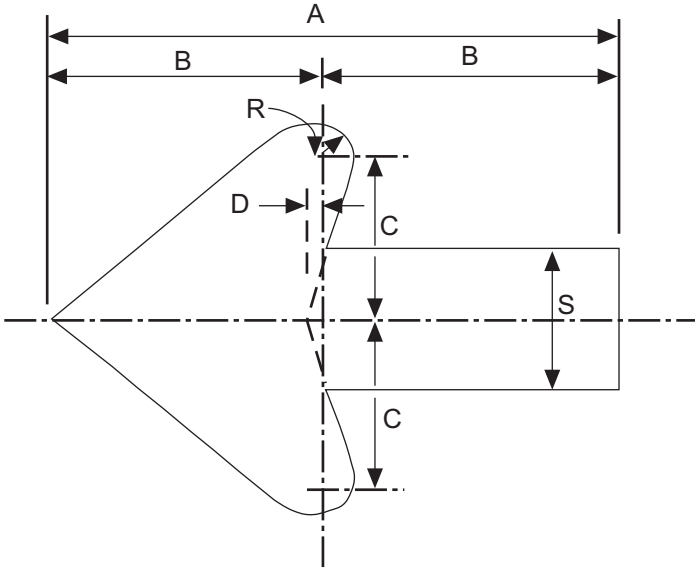

DIMENSIONS IN (MILLIMETERS)					
A	B	C	D	R	S
225	112	64	8	11	56

DIMENSIONS IN (INCHES)					
A	B	C	D	R	S
9	4 1/2	2 9/16	5/16	7/16	2 1/4

APPENDIX B-4B

10/97

8 1/2 " X 10" ARROW DETAILS

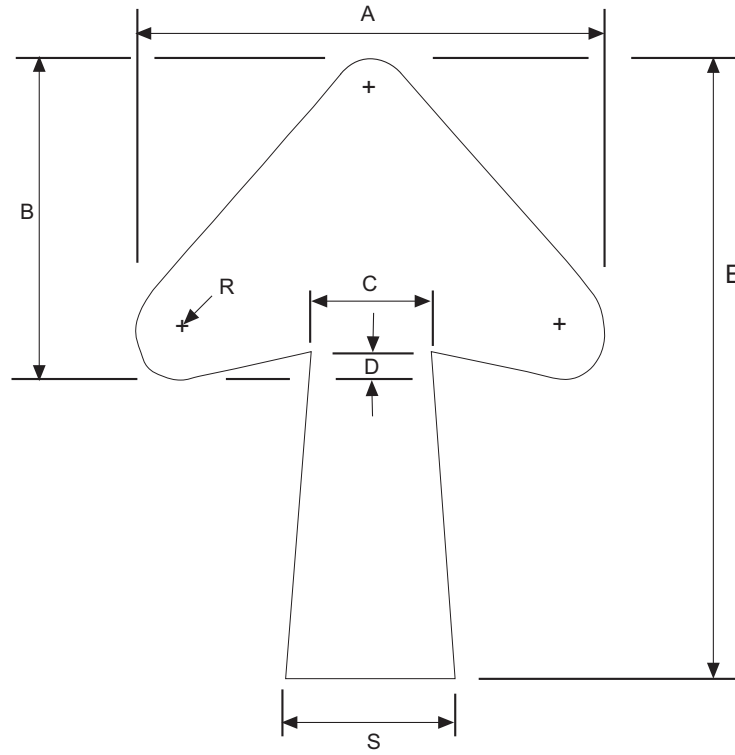

DIMENSIONS IN (MILLIMETERS)						
A	B	C	D	E	R	S
213	144	50	15.63	250	9.38	62.5

DIMENSIONS IN (INCHES)						
A	B	C	D	E	R	S
8 1/2	5 3/4	2	5/8	10	3/8	2 1/2

APPENDIX B-6A

12/94

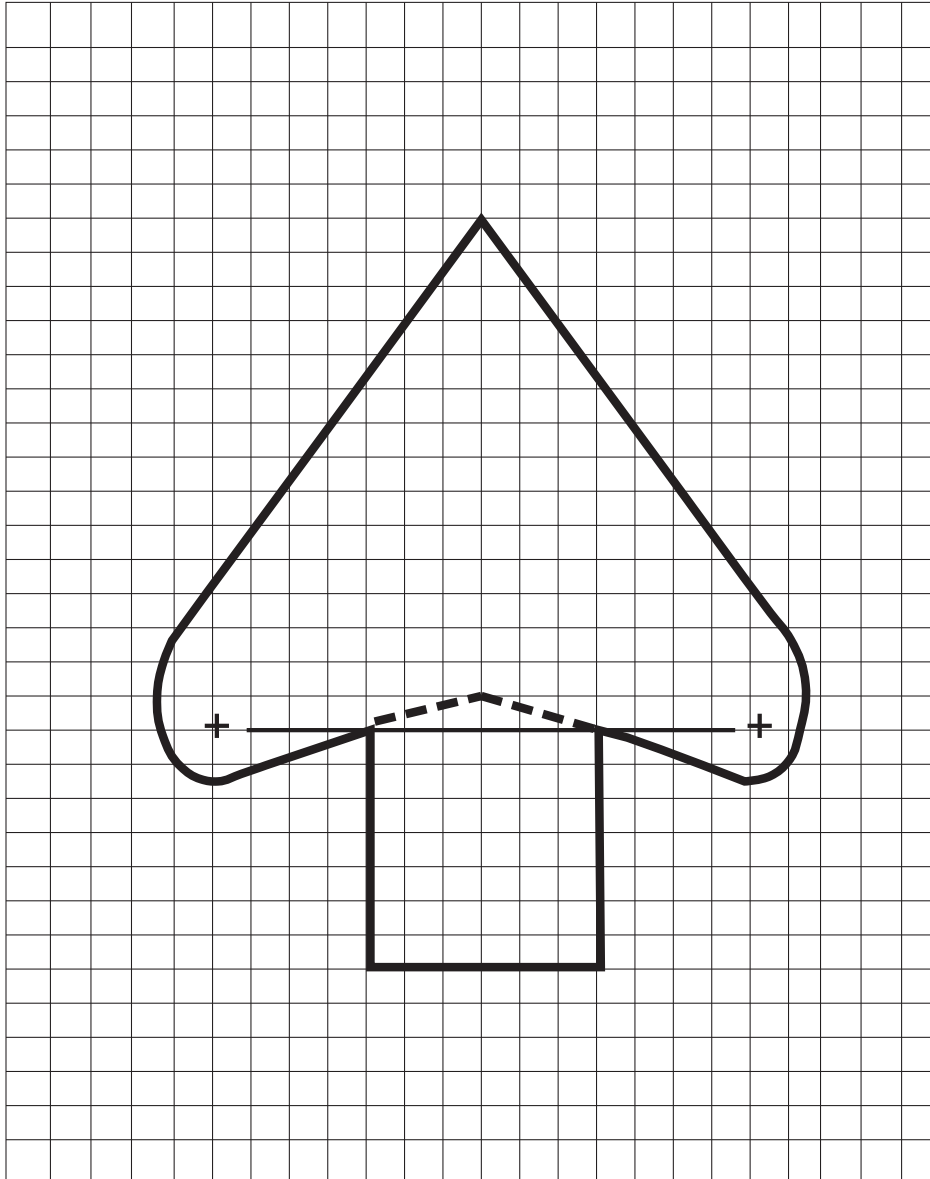

STANDARD ARROW

APPENDIX B-7

5/06

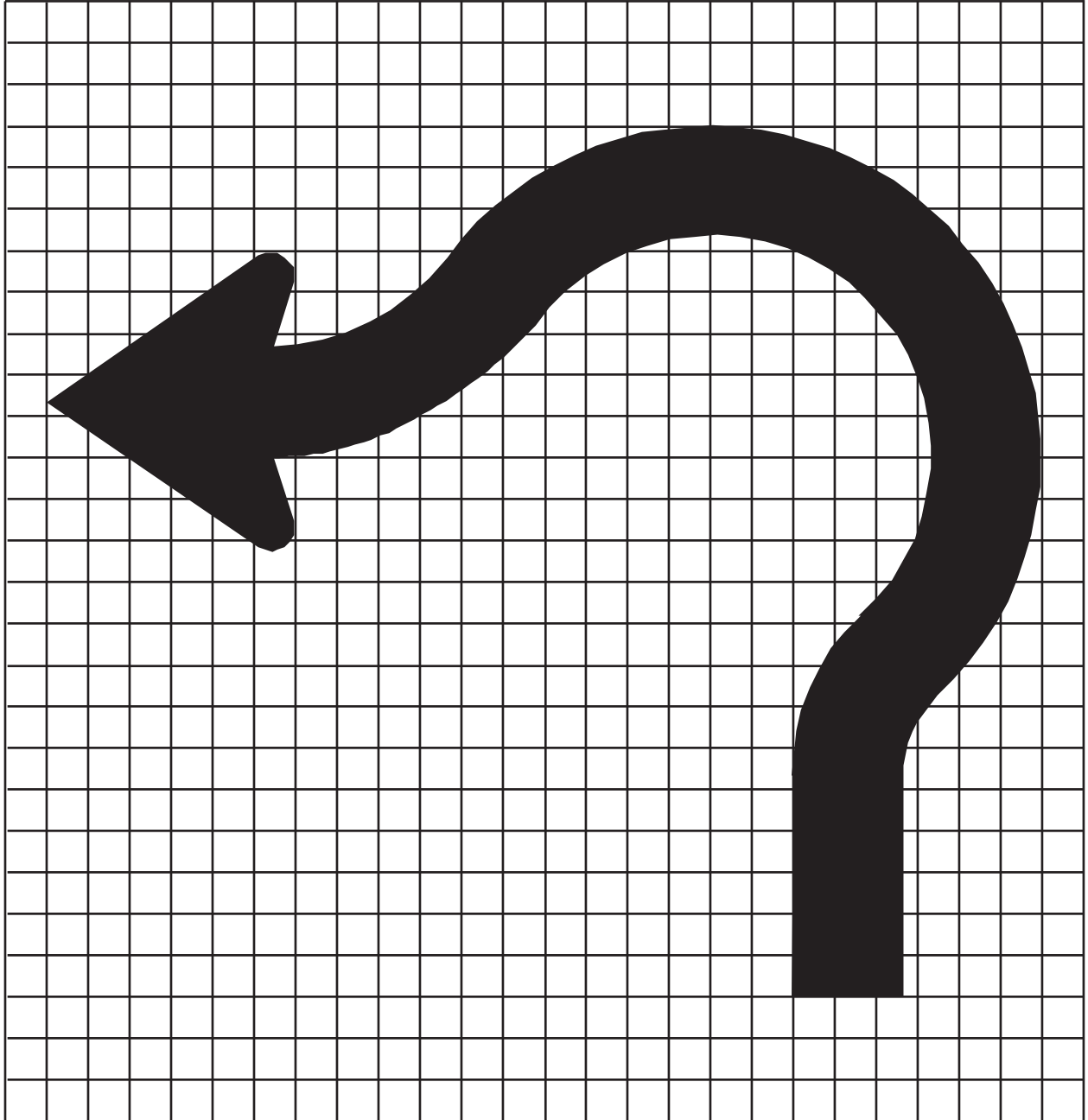

APPENDIX D-26A

3/06

