

HIGH MAST TIMBER LUMINAIRE SUPPORT

Shown for 480 VAC power feed.
Increase conductor and fuse size
as required for 240 VAC power feed.

- KEY**
- (1) Galvanized steel mast arm - configuration varies with manufacturer
 - (2) Luminaire - see Contract for type and number
 - (3) Mounting height - roadway to luminaire elevation difference ± 2%, see Contract
 - (4) Mast arm length - see Contract
 - (5) 5/8" galvanized thimble eyebolt (single or double) with washers and nuts or eyenut
 - (6) Bonding jumper
 - (7) Pole and bracket cable
 - (8) Equipment grounding conductor see Standard Plan J-9a.
 - (9) From ground line to 10' above ground, enclose equipment grounding conductor in galvanized steel conduit, code sized. Above 10' from ground, staple equipment grounding conductor to pole. Connect to supplemental ground per Standard Plan J-9a.
 - (10) Service wedge clamp
 - (11) ACSR triplex or fourplex conductors - see Contract
 - (12) Copper split bolt connector
 - (13) Messenger cable
 - (14) Insulating tape for waterproof connection
 - (15) Fused quick disconnect - use 30 amp fuses for high mast supports
 - (16) Weatherhead - size as required
 - (17) Steel conduit
 - (18) 8" x 8" x 4" NEMA 3R junction box with raintight hubs and removable cover
 - (19) Grounding lug
 - (20) 12 pole terminal block
 - (21) Direct burial conductors or galvanized steel conduits with conductors - see Contract
 - (22) Grounding bushing
 - (23) Supplemental ground - see Standard Plan J-9a.
 - (24) Class 5 timber pole - length sufficient for mounting height and burial depth
 - (25) Class 2 timber pole - length sufficient for mounting height and burial depth.
 - (26) 5/8" x 9" step bolt
 - (27) 1/4" x 10" plate collar bent to fit pole diameter (8" - 10")
 - (28) 3/8" x 4" machine bolts (four required) with washers and nuts
 - (29) 1/2" lag bolts (six required) - drill 9/16" hole in plate
 - (30) 2" pipe
 - (31) 3/4" wire hole 2" from gusset plate, smooth hole edges
 - (32) 1" nonmetallic conduit with 3/4" straps at code spacing
 - (33) Distance varies, 35' MIN, 50' MAX, depending on line clearance requirements

- NOTES:**
1. Timber luminaire supports are allowed only for temporary installations where breakaway or slip bases are not required.
 2. When down guys are required, See Standard Plan J-7d.

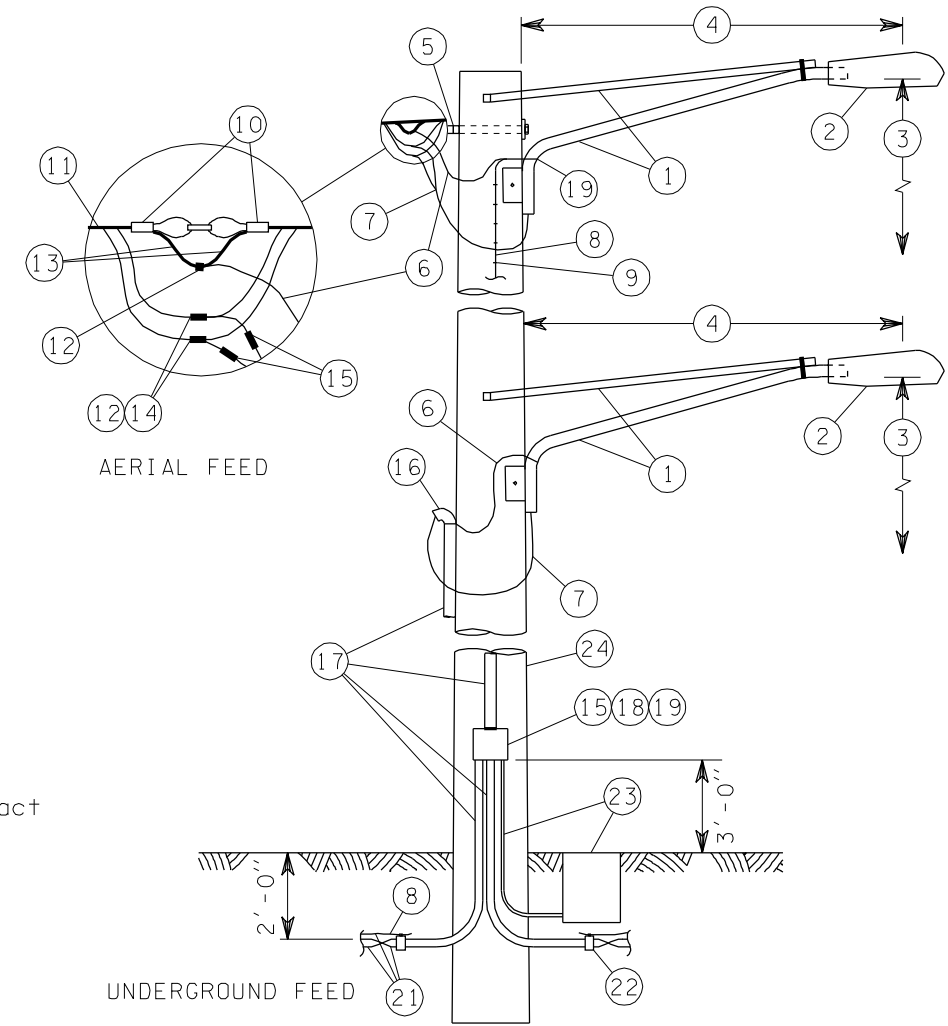

TIMBER LUMINAIRE SUPPORT

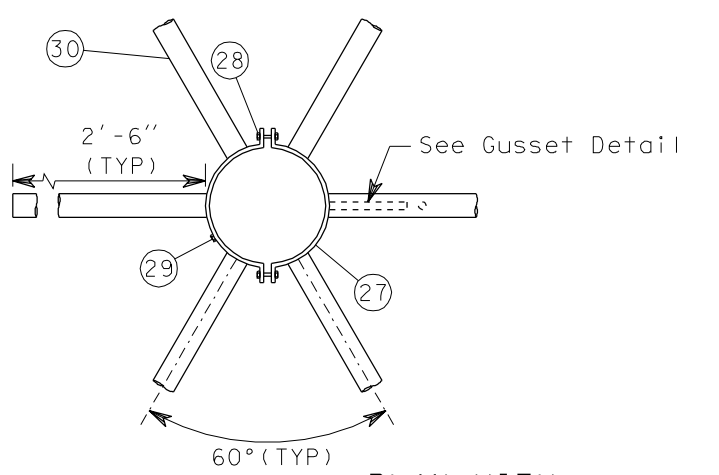

PLAN VIEW LUMINAIRE SUPPORT BRACKET
GALVANIZE AFTER FABRICATION

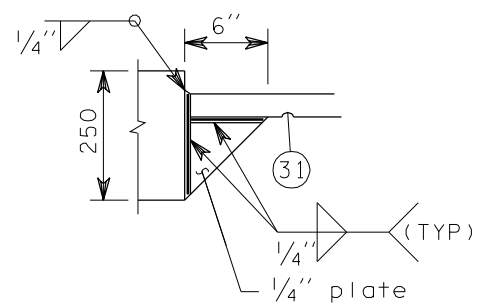

GUSSET DETAIL

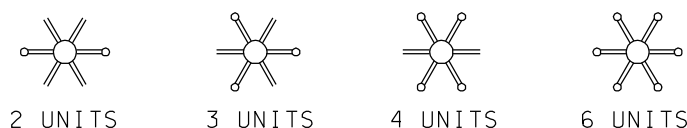

PLAN VIEW TYPICAL LUMINAIRE MOUNTING CONFIGURATIONS

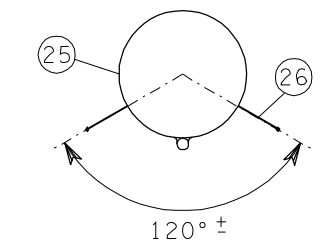

STEP BOLT PLACEMENT



TIMBER LIGHT STANDARDS STANDARD PLAN J-1f

APPROVED FOR PUBLICATION

Clifford E. Mansfield 6/23/00

DEPUTY STATE DESIGN ENGINEER DATE
WASHINGTON STATE DEPARTMENT OF TRANSPORTATION
OLYMPIA, WASHINGTON

5/00	REPLACED PLAN TITLE REFERENCES WITH PLAN NUMBERS.	TWS
DATE	CORRECTED KEY NOTE 5.	BY
	REVISION	

NOTE: THIS PLAN IS NOT A LEGAL ENGINEERING DOCUMENT BUT AN ELECTRONIC DUPLICATE. THE ORIGINAL, SIGNED BY THE ENGINEER AND APPROVED FOR PUBLICATION, IS KEPT ON FILE AT THE WASHINGTON STATE DEPARTMENT OF TRANSPORTATION. A COPY MAY BE OBTAINED UPON REQUEST.