

DRAWN BY: ADAM COCHRAN

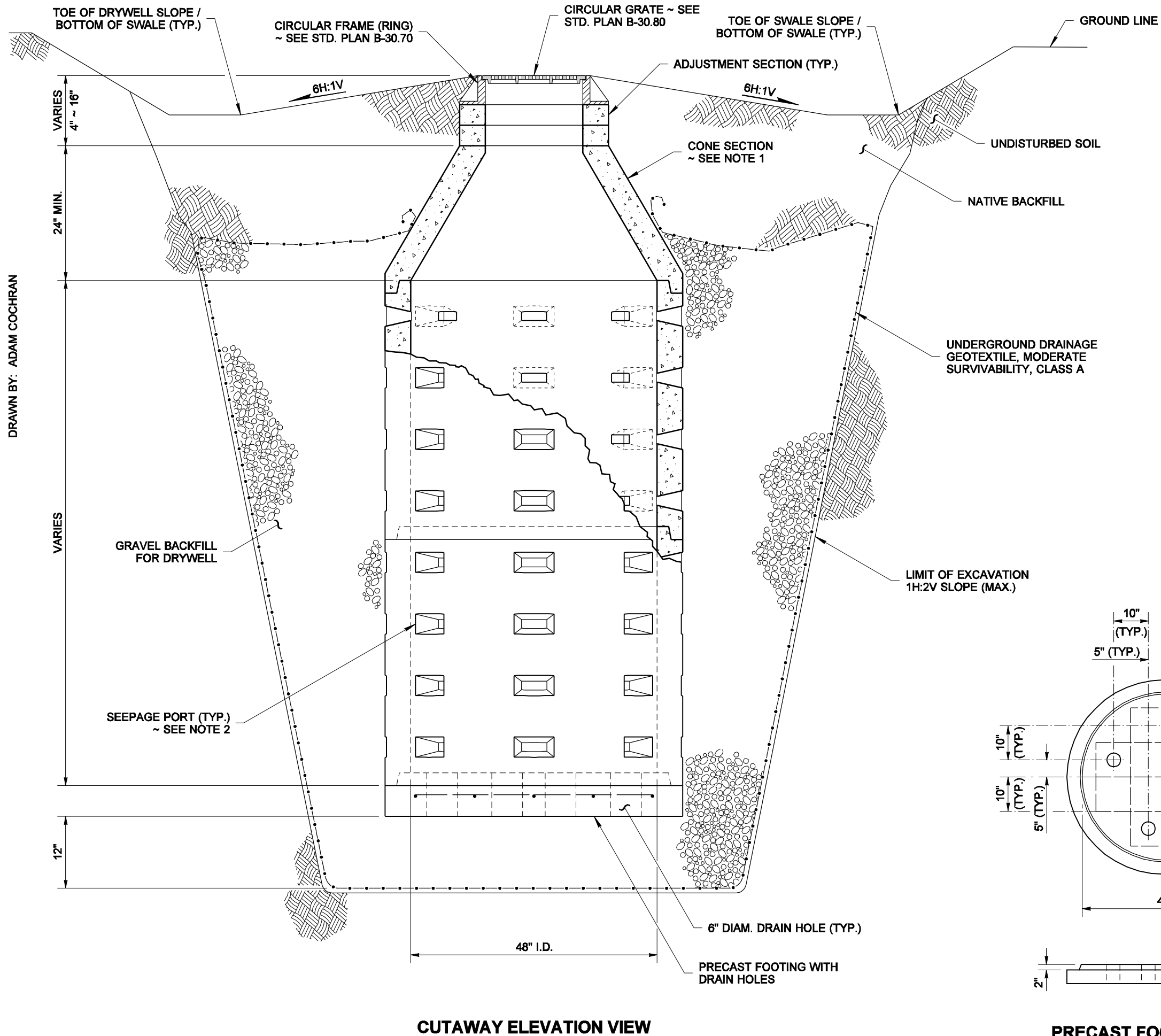

CUTAWAY ELEVATION VIEW

NOTES

1. Precast cone sections may be eccentric or concentric.
2. Seepage port orientation varies among manufacturers.

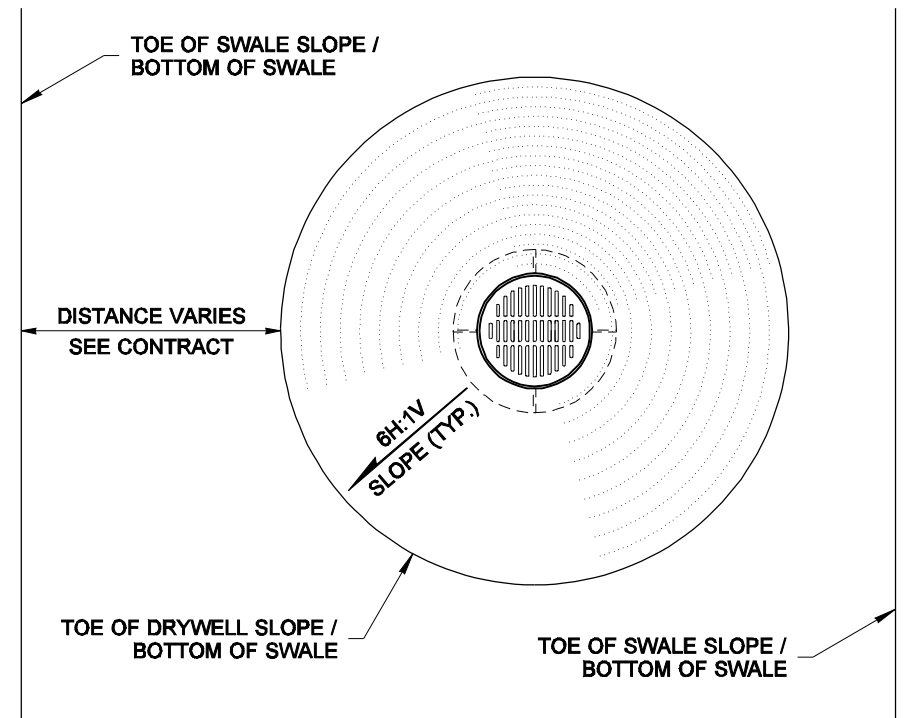

PLAN VIEW

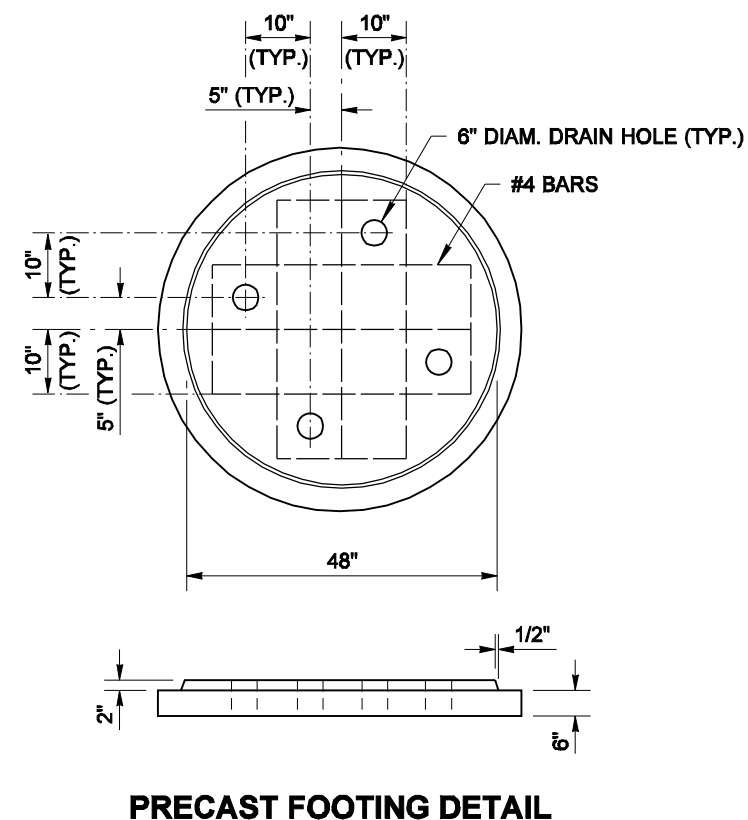

PRECAST FOOTING DETAIL



EXPIRES JULY 1, 2007

NOTE: THIS PLAN IS NOT A LEGAL ENGINEERING DOCUMENT UNLESS IT IS SIGNED BY A REGISTERED PROFESSIONAL ENGINEER AND APPROVED FOR PUBLICATION. IT IS KEPT ON FILE AT THE WASHINGTON STATE DEPARTMENT OF TRANSPORTATION. A COPY MAY BE OBTAINED UPON REQUEST.

**DRYWELL TYPE 1
(FOR SWALE)**

STANDARD PLAN B-20.20-01

SHEET 1 OF 1 SHEET

APPROVED FOR PUBLICATION

Kevin J. Dayton 11-21-06
STATE DESIGN ENGINEER DATE

