

DRAWN BY: LISA CYFORD

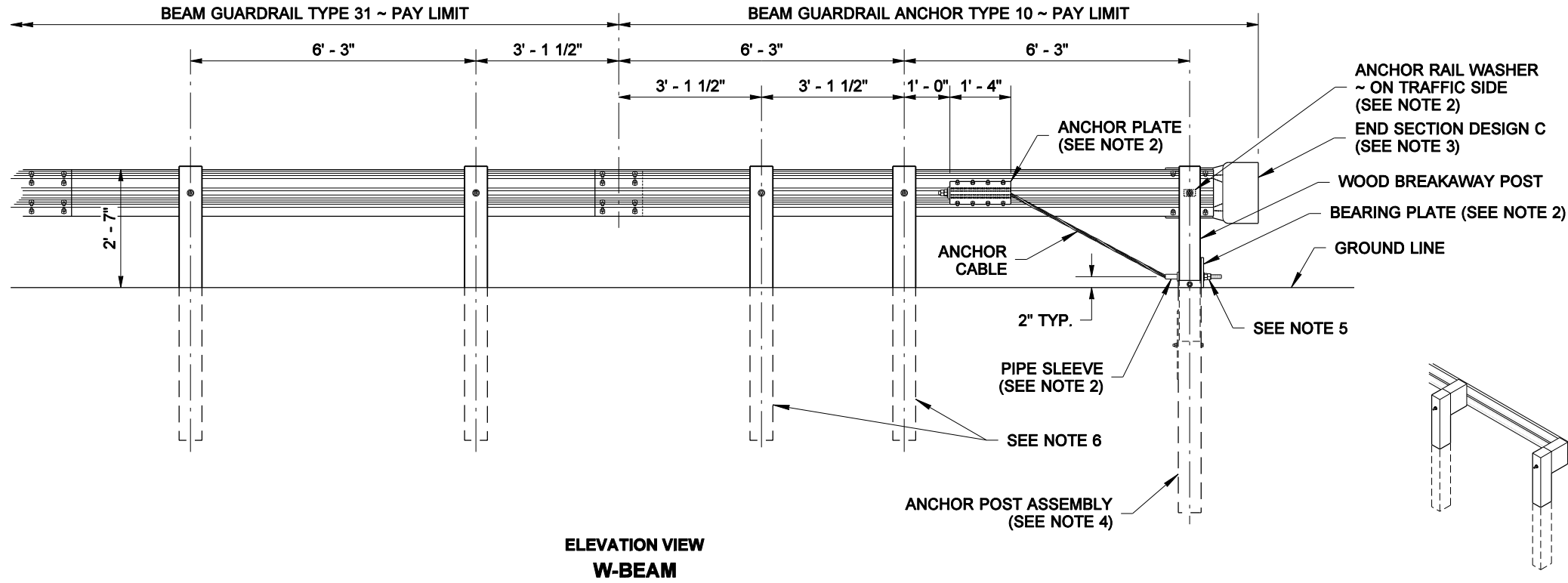

**ELEVATION VIEW
W-BEAM**

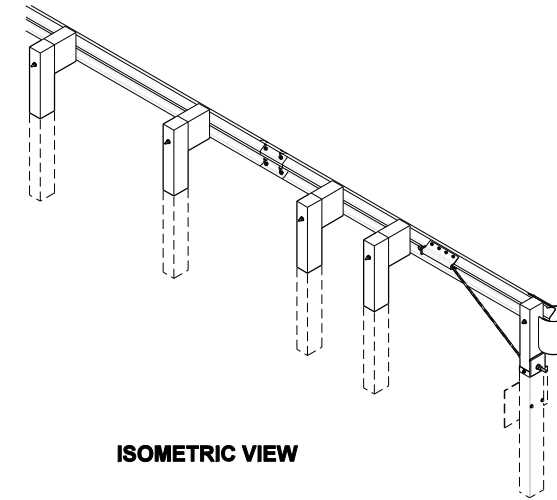

ISOMETRIC VIEW

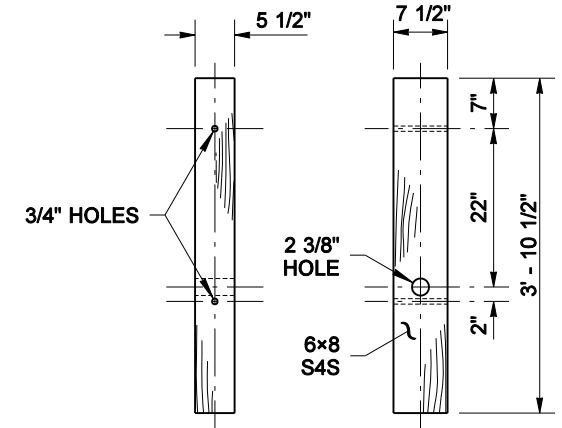

**WOOD BREAKAWAY
POST DETAIL**

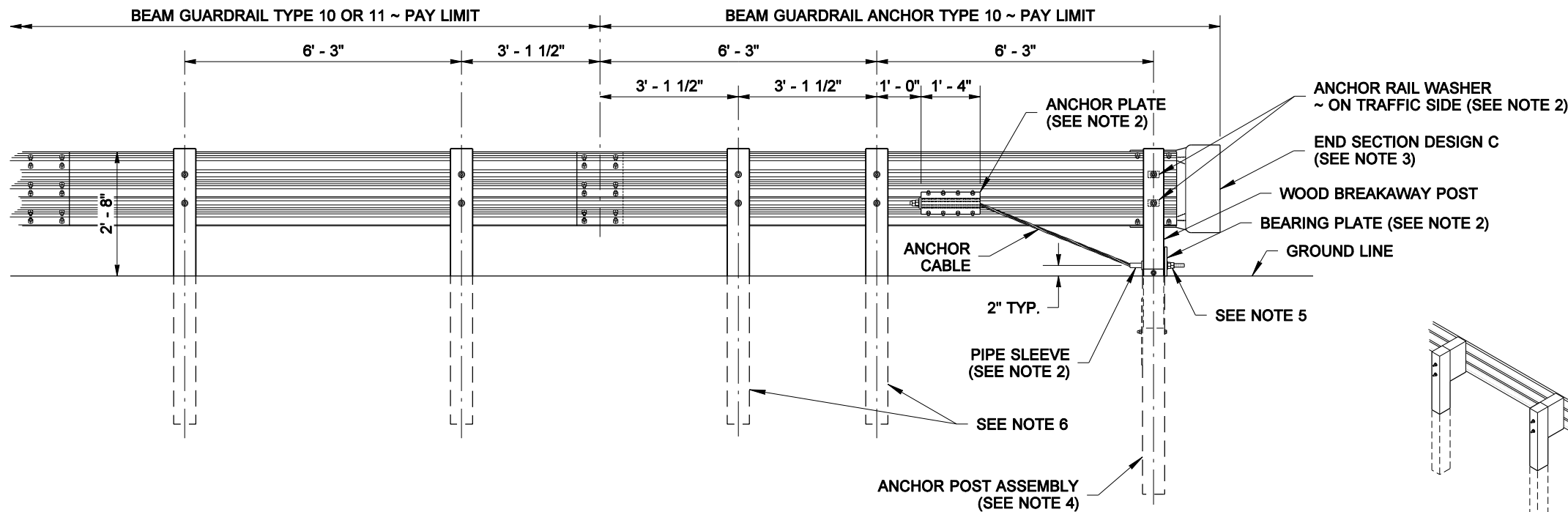

**ELEVATION VIEW
THRIE BEAM**

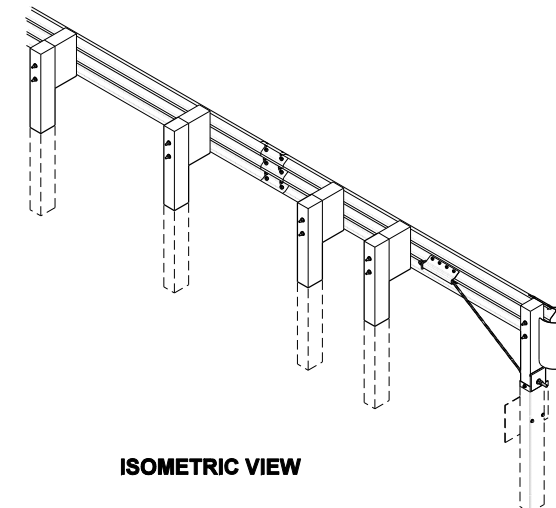

ISOMETRIC VIEW

NOTES

1. For use on the end of guardrail runs when a crashworthy terminal is not required.
2. For additional details not shown, see **Standard Plan C-6c**.
3. For End Section details, see **Standard Plans C-7 and C7a**.
4. For Anchor Post Assembly details, see **Standard Plan C-1b**. Use detail on this plan for Wood Breakaway Post. (No Block on this post).
5. Fasten the Anchor Cable using two 1" nuts and washer, at both ends of cable. Outside nut shall be torqued against inside nut a minimum of 100 ft.-lbs.
6. Posts shall match those of connecting run: Timber or Steel.



NOTE: THIS PLAN IS NOT A LEGAL ENGINEERING DOCUMENT UNTIL IT IS APPROVED AND SEALED BY THE ENGINEER. THE ENGINEER'S APPROVAL IS REQUIRED FOR THE PLAN TO BE USED FOR CONSTRUCTION. A COPY MAY BE OBTAINED UPON REQUEST.

**BEAM GUARDRAIL (TYPE 31)
ANCHOR TYPE 10**

STANDARD PLAN C-23.60-01

SHEET 1 OF 1 SHEET

APPROVED FOR PUBLICATION

Pasco Bakotich III 10-14-09

STATE DESIGN ENGINEER DATE

