

DRAWN BY: BILL BERENS

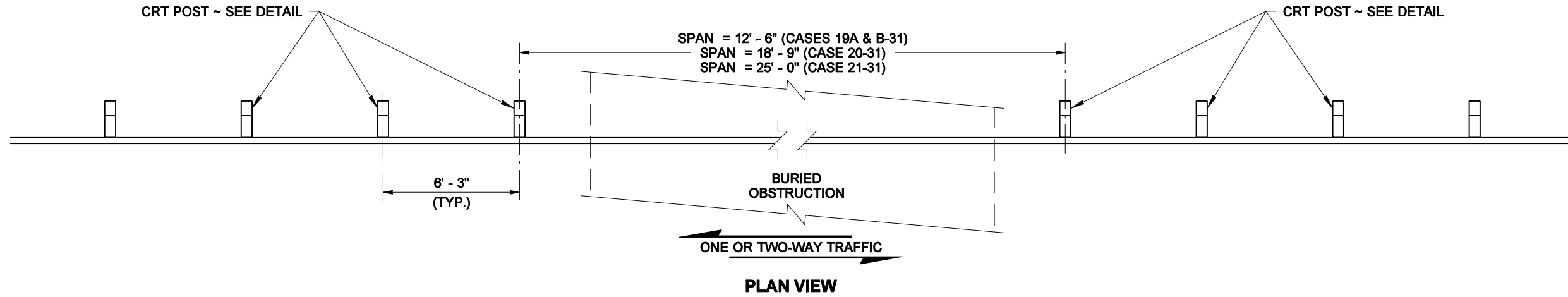

NOTE

- For additional details not shown, see **Standard Plan C-1b**.

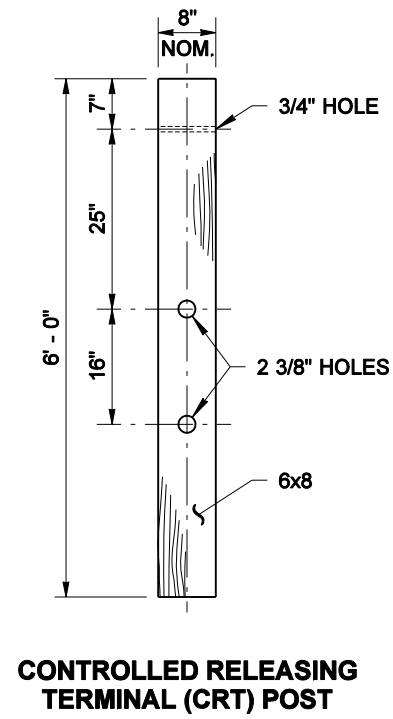
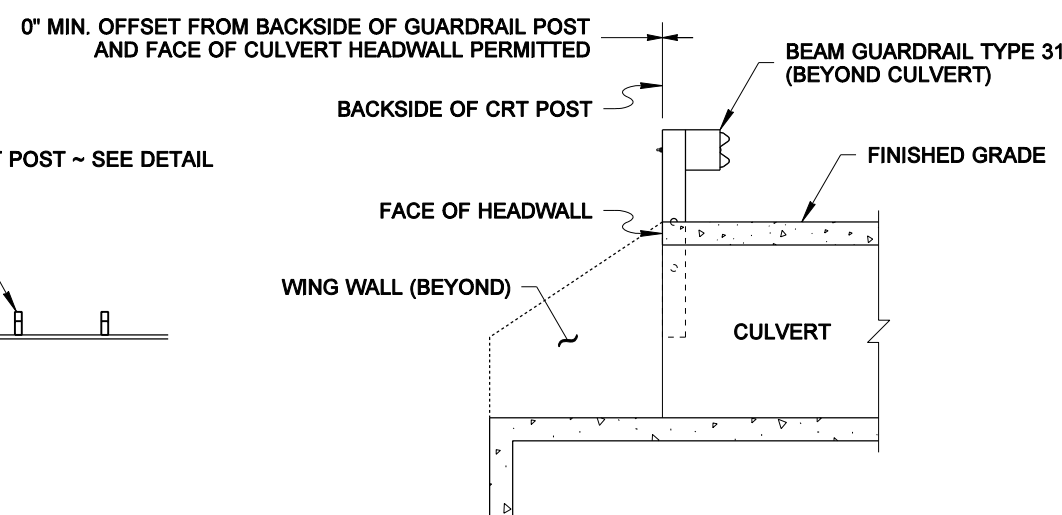
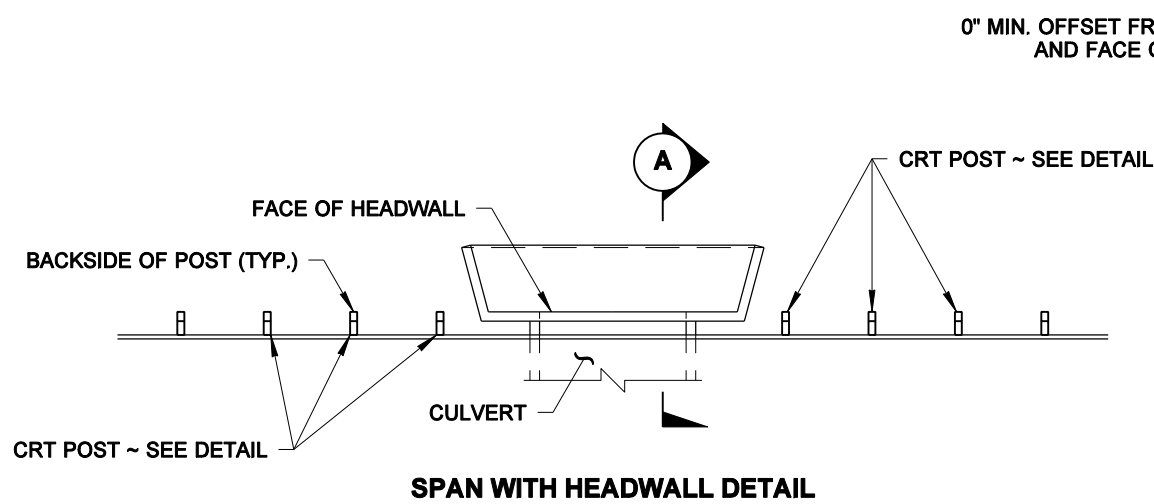
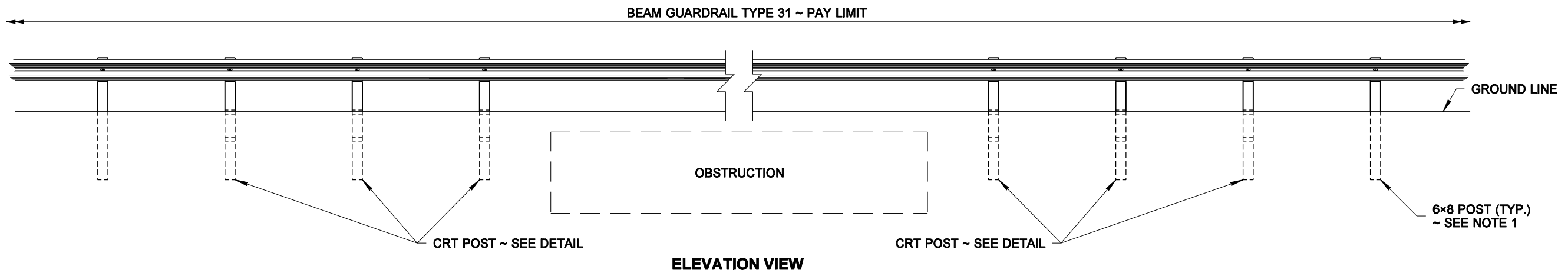

NOTE: THIS PLAN IS NOT A LEGAL ENGINEERING DOCUMENT UNTIL IT IS APPROVED BY THE ENGINEER AND APPROVED BY THE BOARD OF ENGINEERS AND SURVEYORS OF THE STATE OF WASHINGTON. A COPY MAY BE OBTAINED UPON REQUEST.

**BEAM GUARDRAIL TYPE 31
PLACEMENT 12'-6" (CASE 19A/B -31),
18'-9" (CASE 20-31) OR
25'-0" SPAN (CASE 21-31)
STANDARD PLAN C-20.40-01**

SHEET 1 OF 1 SHEET

APPROVED FOR PUBLICATION

Pasco Bakotich III 10-14-09
STATE DESIGN ENGINEER DATE

