

# I-90 HOMER HADLEY FLOATING BRIDGE

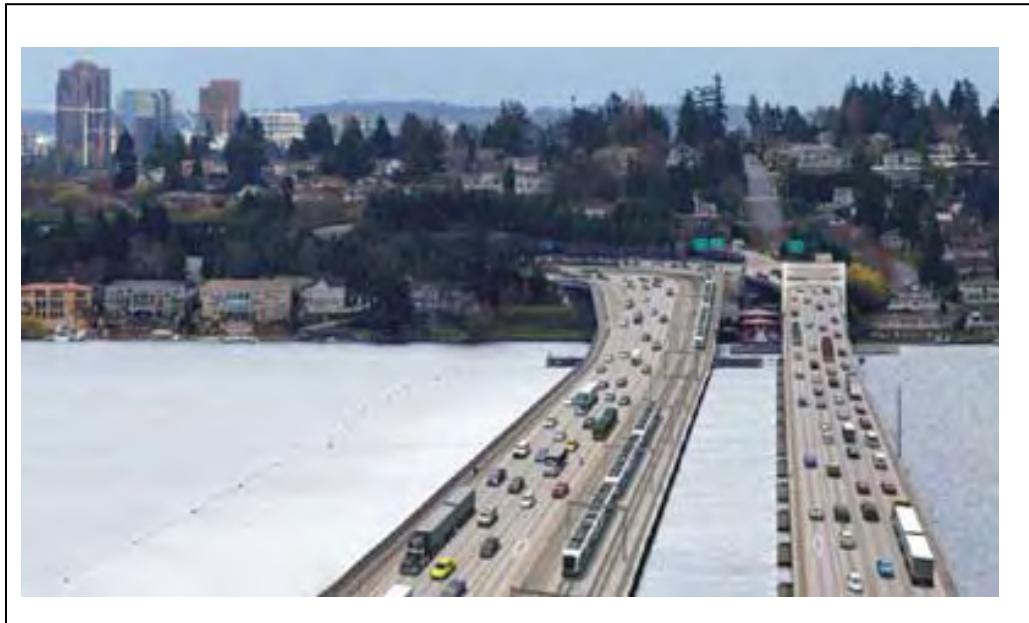
---

Independent Review Team

Light Rail Train Impacts

---

Final Report



Prepared by

**SC SOLUTIONS**

In Association with



For



15 September 2008

# I-90 HOMER HADLEY FLOATING BRIDGE

## Independent Review Team - Light Rail Train Impacts



---

### TABLE OF CONTENTS

#### INTRODUCTION / EXECUTIVE SUMMARY

#### APPENDIX A: ISSUES REPORT

#### APPENDIX B: TECHNICAL MEMOS

- B1: OVERHEAD CONTACT SYSTEM POLE LOAD ANALYSIS*
- B2: TORSIONAL ANALYSIS*
- B3: EXPANSION JOINT ANALYSIS*
- B4: VEHICLE DYNAMICS ANALYSIS*
- B5: SEISMIC VULNERABILITY ASSESSMENT OF THE WEST APPROACH AND TRANSITION SPANS*
- B6: WAVE CLIMATOLOGY*
- B7: IMPACT OF STRAY CURRENT ON REMAINING SERVICE LIFE*
- B8: RESISTIVITY, UNIT WEIGHT AND ABSORPTION TEST RESULTS*

#### APPENDIX C: MEETING NOTES

#### APPENDIX D: REFERENCES

# I-90 HOMER HADLEY FLOATING BRIDGE

Independent Review Team - Light Rail Train Impacts



## ***INTRODUCTION / EXECUTIVE SUMMARY***

---

**SC SOLUTIONS** In Association with

 **THE GLOSTEN ASSOCIATES**  
*Consulting Engineers Serving the Marine Community*

 **RUSSELL CORROSION CONSULTANTS, INC.**  
Columbia, Maryland  
Garden City, New York

 **CONCORR, Inc.**  
CONCRETE CORROSION SPECIALISTS

**To: Washington State Legislature, Joint Transportation Committee  
Senator Mary Margaret Haugen, Co-Chair  
Representative Judy Clibborn, Co-Chair**

**From: Independent Review Team (IRT)**

Chuck Ruth, S.E., SC Solutions, Inc., Team Leader

Tom Ballard

J. Thomas Bringloe, P.E., The Glosten Associates, Inc.

Steve Nikolakakos, P.E., Russell Corrosion Consultants, Inc.

Ali Akbar Sohangpurwala, CONCORR, Inc.

**Date: September 15, 2008**

**Project: Impact of Placing Light Rail Transit (LRT) on the Homer Hadley Floating Bridge and Approach Spans**

**Subject: Recommendations**

The Independent Review Team (IRT) began work on the Light Rail Transit (LRT) impact study in April of 2008. In order to obtain a working knowledge of the proposed LRT project and the existing facility, the IRT:

- Inspected the floating bridge.
- Interviewed agency project stakeholders.
- Reviewed all documents associated with the condition of the existing bridge and the impact of placing LRT on the floating bridge and approach spans.

Based on this extensive study, analysis, and discussion with Sound Transit and WSDOT, the IRT

- Identified 23 issues related to the impact of the proposed LRT installation.
- Determined that installation of LRT on the Homer Hadley Floating Bridge and approach spans can be addressed or mitigated, providing that the IRT resolutions and recommendations are incorporated.

Since many of the issues require additional study, analysis, and design, the IRT recommends that an independent review or peer review panel be organized to provide oversight throughout the LRT East Link design process.

### **Background**

The central Puget Sound region is home to Fortune 500 corporations such as Microsoft, Boeing, and Starbucks, and serves as a primary gateway for the movement of goods to and from East Asian markets through its world class ports and terminal facilities. There are only two transportation corridors crossing Lake Washington, which are the I-90 and the SR 520 Floating Bridges. Population growth has increased congestion on these key regional links. Central Puget Sound had an estimated 3.5 million people in 2005 and is projected to grow to over 4.6 million by 2030, with notable growth assumed on the east side of Lake Washington.

Past studies and regional agreements have identified I-90 as the preferred corridor for high capacity LRT. The I-90 roadway and floating bridges link the City of Seattle with communities on the east side of Lake Washington such as Bellevue and Issaquah, with I-90 serving as the only connection between Mercer Island and the mainland. During an

average weekday, the I-90 roadway carries approximately 133,000 vehicles per day. It is for these reasons that Sound Transit is proposing the corridor to accommodate high-capacity transit in the form of light rail across the I-90 floating bridge.

The Homer M. Hadley Floating Bridge was designed in the early 1980s. The *1976 Memorandum Agreement* signed by communities and jurisdictions along the I-90 corridor provides for the development of high-capacity transit in the center roadway of the Homer M. Hadley Floating Bridge. The bridge design process included analysis of the bridge for light rail (LRT), though the design characteristics from the current proposed Sound Transit LRT. The East Link project is currently in the environmental review and conceptual design phase, with preliminary engineering beginning in 2009, and final design anticipated to start in 2011, and revenue operation in 2020.

## **Purpose and Scope**

The purpose of this independent review is to evaluate the original bridge analysis, subsequent studies, tests, and preliminary concept studies, and to determine the impact of installation and operation of LRT on the Homer M. Hadley Floating Bridge and approach spans. While there are similar implementations of LRT across suspension bridges, there is no precedent in the world for implementing light rail across a floating bridge.

The IRT was tasked to:

- Review Sound Transit conceptual design proposals associated with the impacts of an energized electrical LRT system (stray current mitigation).
- Review Sound Transit standard directives drawings for the light rail track and power system; review and recommend design approaches for attaching the LRT track system to the pontoons, elevated roadways, and transition spans.
- Review the previous load test data, perform preliminary analysis as required to evaluate structural impact, and recommend any additional analysis.
- Assess impacts of an LRT track system on pontoon weight mitigation/balance, and on existing maintenance and operations policies; recommend new policies, maintenance criteria, and potential work force and maintenance cost increases needed to accommodate LRT beyond the current bridge maintenance practices and budget.
- Identify the effects of the LRT dead/live loads and rails on the transition spans expansion joints, bridge decks, and other bridge elements.
- Review and analyze the Sound Transit conceptual rail expansion joint design and provide recommendations.

The Independent Review Team concludes that all impact issues identified can be addressed or mitigated. However, several of the issues require significant further analysis, design, engineering and testing and have the high potential to impact the cost estimates, schedules, and reliability of LRT operation, and should be resolved at the earliest stages of the project design.

Although not in the scope of this independent review, the IRT also recommends that Washington State DOT, and Sound Transit determine the risks and costs associated with the potential loss and reconstruction of the Homer M. Hadley Floating Bridge and approaches. There are several potential impact elements associated with placing LRT on the Homer M. Hadley Floating Bridge, approach spans, and transition spans, which

require careful attention during design to avoid reducing the remaining life of the bridge. It is recommended that the risk, in terms of cost, take into account the:

- Cost to redesign bridge and approaches.
- Cost to reconstruct a new floating bridge and approaches.
- Economic impact costs associated with the total time to accomplish the tasks identified above.

Having this information will be a valuable measure for determining the benefit of LRT mitigation measures. However, the financial risk from the loss of this transportation facility should not affect the engineering feasibility of placing LRT on the bridge.

## **ISSUES**

Each issue's importance was rated with respect to the impact of design, construction, maintenance, and cost for LRT installation.

### ***Importance Definition***

High: These issues have the potential to have a major installation impact or represent a potential major cost impact to the East Link Project. An action plan was developed by Sound Transit and/or Washington State DOT to address these issues during concept studies and before preliminary design is started.

Medium: These issues will most likely not have a major impact on installing LRT on the Homer M. Hadley floating bridge, but should be resolved before preliminary design is complete and final design proceeds. These are important issues identified by the Independent Review Team, but ones that can be mitigated or addressed. An action plan was developed by Sound Transit and/or Washington State DOT to address these issues during preliminary design.

Low: These issues are important, but will have no significant impact on LRT installation. This issue can be resolved during the final design, but before construction begins

The issues were placed into 6 categories, as follows.

- General Design Policy
- Stray Current Mitigation Measures
- Impact of LRT Track System Installation on the Bridge
- Rail Expansion Joint Design and Prototype Testing
- Seismic Vulnerability of Structures
- Miscellaneous

A brief summary of each issue follows, as identified by the IRT. For additional information on these issues, refer to the attached IRT *Issue Resolution Report (Appendix A)*, which contains:

- Detailed technical information.
- References provided by Sound Transit and Washington State DOT.
- Solutions and/or responses to the issues provided by Sound Transit and/or WSDOT
- Detailed findings and recommendations from the IRT.

### ***GENERAL DESIGN POLICY (Issues K, T, & W)***

#### ***Technical Terms***

*Life Expectancy*: The designated goal for years of public use of a transportation facility, that is typically used as a basis for design of the facility.

*Criteria*: The technical standard or basis for design or evaluation of a facility.

*Blue Ribbon Panel Recommendations:* Recommendations made by the governor-appointed (Blue Ribbon) panel as a result of the sinking of the original Lacey V. Murrow Floating Bridge during retrofit construction in November of 1990.

### **Criteria**

(Issue K, Importance – High)

Criteria should be established for the Independent Review Team to evaluate issues identified.

**Resolution:** Appropriate design criteria was discussed with agency stakeholders and provided to the IRT as a basis for evaluation.

### **Life Expectancy**

(Issue T, Importance – High)

In order for the Independent Review Team to assess the impact of placing the LRT on the bridge, Washington State DOT and Sound Transit should state their goal for life expectancy of bridge.

**Resolution:** WSDOT and Sound Transit discussed this issue and determined that the desired life expectancy for the floating bridge and approaches is 100 years (beginning the date that the original bridge was put in operation), which provides approximately 70 years effective bridge life after initiation of LRT operations).

### **Implementation of Blue Ribbon Panel Recommendations**

(Issue W, Importance – Low)

Based on lessons learned from the sinking of the Lacey V. Murrow Floating Bridge, additional changes may be required for LRT installation to meet "Blue Ribbon Panel" recommendations.

**Resolution:** The Blue Ribbon Panel recommendations will not likely raise any significant project impact issues. However, they contain provisions that the designers will incorporate into design and construction work on the bridge and will likely affect Washington State DOT and Sound Transit maintenance and operation procedures and priorities.

## ***STRAY CURRENT MITIGATION MEASURES (ISSUES F, H, P, Q, U)***

### ***Technical Terms***

**Stray Current:** Electrical current that flows through unintended paths. The LRT is powered by a direct current electrical circuit, where one leg of the circuit is the overhead conductor wire and the return leg of the circuit is the steel track that returns current to ground at the power sub station. The track fasteners will be insulated; however, if that insulation breaks down, some current (stray current) may return to ground through alternate paths (such as the bridge structure and water) and cause corrosion.

**Cathodic Protection:** A technique to control the corrosion of a metal surface.

**Anchor Cables:** The woven steel cables that tie the floating bridge to the anchors embedded in the lake bottom.

**Concrete Strength and Resistance:** Concrete strength is specified at the time of construction, but concrete continues to gain strength over time, especially in a damp environment. By taking core samples and testing them, it is possible to determine if this nearly 30 year old bridge now has greater structural capacity than was assumed in the original design. The same samples can be used to measure the electrical resistance of the concrete, which is an important parameter in corrosion calculations.

**Discussion of Stray Current Mitigation Measures and its Impact:** Previous reports have identified that stray current can pose significant design and mitigation issues for a LRT system installed on the Homer M. Hadley Bridge. Stray current is a problem on all electrified rail systems. However, methods are available to control or minimize its impact. Since LRT has never been installed on a floating bridge, the impact of stray current needs to be analyzed with a higher degree of scrutiny. All electrical systems have an intended path of current flow. Some of the system current can leak and flow through unintended paths, and in doing so can cause corrosion of the metallic elements that are present in those unintended paths. In the case of the light rail, a small portion of the current that flows through the rails can leak into the supporting structure; i.e., the floating bridge or approach spans. This current may find its way through the reinforcement, which has low electrical resistance. To complete its electrical circuit, this current must be discharged from the concrete structure. At the discharge points, corrosion of the reinforcement will occur. On a floating structure, this corrosion can create cracks that can compromise floating bridge water tightness and ultimately its ability to stay afloat. Mitigation of this stray current is a mandatory element of the LRT installation. Long term maintenance of the stray current mitigation system is as important as installing the various stray current control measures

### **Stray Current Mitigation**

(Issue F, Importance – High)

To meet the minimum requirements for stray current mitigation, Sound Transit should adopt the North Link/Airport Link Stray Current Mitigation design criteria for the Homer M. Hadley Floating Bridge installation, with appropriate modifications and measures to meet the special requirements of this bridge.

**Resolution:** Sound Transit proposes to utilize more stringent design criteria for stray current analysis. They have also agreed to provide a multi-level stray current collection system, and to provide a stray current monitoring system. These measures (if properly implemented, monitored, and maintained) should protect the floating bridge.

### **Cathodic Protection System**

(Issue H, Importance – High)

Since the Homer M. Hadley Bridge and Lacey V. Murrow Bridge are in close proximity, and their respective anchor cable systems pass very close to the pontoons of the adjacent bridge, stray current and cathodic protection system interference should be considered, and compatibility of the two systems assured.

**Resolution:** An upgraded cathodic protection system is proposed for both the Homer M. Hadley Floating Bridge and the adjacent Lacey V. Murrow Floating Bridge as a backup to the primary stray current collection system for the LRT installation.

### **Modification of Current Bridge Inspection Procedures**

(Issue Q, Importance – Low)

For Washington State DOT to ensure safe operation of LRT on the Homer M. Hadley Bridge, modification of current bridge inspection procedures is recommended.

**Resolution:** The IRT recommends that the current inspection procedures and frequency be modified to, in a timely manner, detect and mitigate/repair any problems that may have resulted from the operation of the LRT. In addition, technology-specific maintenance and inspection staff should be added to address the changed use of this



transportation facility. Both Sound Transit and WSDOT have agreed to implement these recommendations.

### **Determine In-Place Strength and Resistance of Existing Concrete**

(Issue P, Importance – Medium)

To provide rational engineering inputs for performing stray current damage estimates, the strength and resistance of existing concrete should be determined.

**Resolution:** Sampling and testing has been completed and results will be incorporated into the design.

### **Identification/Response to Stray Current Mitigation Leaks**

(Issue U, Importance – Medium)

In order to protect the bridge from stray current effects and provide for rapid identification and repair, methods for identifying stray current leakage and a response/repair plan should be in place.

**Resolution:** Sound Transit proposes to the implementation of monitoring and a response repair plan for stray current. The repair/maintenance procedure should include a method of inspection and evaluation if an alarm is initiated from the monitoring system.

### **IMPACT OF LRT TRACK SYSTEM INSTALLATION ON THE BRIDGE**

**(ISSUES E, G, N, O)**

#### **Technical Terms**

*Post-Tension Steel:* Special, high-strength steel in the structural concrete that provides internal concrete compression for better resistance to cracking.

*Overhead Contact System (OCS) Supports:* Vertical metal posts attached to the floating bridge, approach spans, and transition spans that support the energizing cables (Overhead Contact System) for LRT.

*Lightning Arrestors:* Vertical metal poles designed to attract and safely disperse lightning strikes.

*Stray Current Discharge:* Stray current that leaks or discharges into Lake Washington.

### **Lightning Protection System**

(Issue E, Importance – Medium)

Since the LRT OCS may attract more lightning than currently strikes the bridge, the need for lightning arrestors on floating bridge and approach spans should be considered.

**Resolution:** A lightning protection system (separate from the stray current system) is proposed by Sound Transit for the bridge and approach spans.

### **Impact of Stray Current on the Lake Environment**

(Issue G, Importance – Low)

Small amounts of stray current will be discharged into the water and, therefore, the impact of stray current dispersion in Lake Washington on the environment and fish should be addressed.

**Resolution:** A technical memorandum was provided by Sound Transit to the IRT indicating that stray current should not have an impact on marine life in the lake.

### **Attachment of OCS Supports to Bridge**

(Issue N, Importance – High)

To avoid damage to the Homer M. Hadley Bridge reinforcing and post-tension steel, attachment of OCS supports to the edge of the bridge deck cantilevers should be carefully designed and detailed to minimize concrete deck penetrations.

**Resolution:** Sound Transit provided the IRT with conceptual OCS and rail post attachment details that minimize penetrations into the existing pontoon concrete deck South cantilever. Further analysis should be performed by Sound Transit to prove the concept during preliminary design.

### **Accurate Location of Existing Concrete Reinforcing**

(Issue O, Importance – High)

To avoid damage to the Homer M. Hadley Bridge, reliable method(s) should be utilized for locating rebar and post tensioning in the bridge deck.

**Resolution:** The IRT has reviewed Sound Transit's evaluation of rebar locating technologies to ascertain their effectiveness in locating reinforcing steel in the deck slab. The method selected for actual construction will depend on the accuracy needed for reinforcing steel location.

## ***RAIL EXPANSION JOINT DESIGN AND PROTOTYPE TESTING***

***(ISSUES A, M, R)***

### ***Technical Terms***

**Track Bridge:** The LRT rail bridge that spans over the major expansion joints at the ends of the floating bridge.

**Prototype:** A full size fabricated model of a design concept (typically tested in accordance with specific criteria).

**Rider Comfort Performance:** Track bridge movements under LRT loads that do not exceed rider comfort limits.

**Storm Water Drainage System:** The drainage system on the existing bridge that collects and discharges rainfall and wind storm spray that fall on the bridge deck.

### **Track Bridge Design and Prototype Testing**

(Issue A, Importance – High)

Since the track bridge is unique and has never before been used on a floating bridge, track bridge/expansion joint design should be accelerated and prototype tested with appropriate performance criteria, including the noise generated by loads passing over the track bridge.

**Resolution:** Prototype testing and vetting of the track bridge concept design needs to be performed as soon as possible. This type of track bridge has never been utilized before, and there are no historical data available for the IRT to judge the feasibility of this concept. However, preliminary analysis by the IRT indicates that the Sound Transit conceptual design track bridge member stresses are within reasonable limits under the application of LRT loads.

### **Rider Comfort Performance of the Track Bridge**

(Issue M, Importance – High)

Since the track bridge is unique and has never been used on a floating bridge before, rider comfort performance for the LRT track bridge at expansion joints should be evaluated.

**Resolution:** The IRT has performed an independent analysis of the Sound Transit track bridge concept, and has concluded that the LRT vehicle will most likely be able to traverse the track bridge during normal conditions without undue discomfort to the riders, but with reduced speed.

### **Storm Water Drainage across the Track Bridge**

(Issue R, Importance – Low)

The track bridge will cross the existing expansion joints, and storm water drainage system modifications must be addressed.

**Resolution:** Sound Transit has provided the IRT with acceptable conceptual details of the method for collecting storm water and transporting it into the existing storm water drainage system.

### **SEISMIC VULNERABILITY OF STRUCTURES (ISSUES C, D)**

#### **Technical Terms:**

*Seismic Vulnerability:* Seismic resistance of a bridge, tunnel, or other structural element for a particular earthquake design event.

*Approach Spans:* The shore-supported bridge spans at the west and east end of the floating bridge.

*Transition Spans:* The spans at each end of the floating bridge that span between the west and east end of the floating bridge, and the west and east approach spans (Supported by the floating bridge at one end, and a shore-supported pier at the other end).

### **Seismic Vulnerability of Approach and Transition Spans**

(Issue C, Importance – High)

Placing light rail on the approach spans and transition spans does not change their seismic vulnerability. However, the conversion of the center roadway to LRT does constitute a significant change-of-use of the bridge and significant capital investment which alters seismic risk prioritization of the I-90 Lake Washington crossing. For LRT, this bridge will be the only link across Lake Washington and is critical link. For WSDOT, conversion of the bridge to LRT reduces the number of vehicle bridges crossing Lake Washington, thus reduces redundancy in the case of a seismic event. The IRT recommends that seismic vulnerability be assessed and retrofit strategies analyzed early in the design process so that the strategies and associated cost can be incorporated into project.

**Resolution:** Sound Transit and WSDOT have agreed that seismic vulnerability studies will be undertaken as an early-start preliminary engineering activity. Retrofit strategies and associated cost estimates will then be developed during preliminary design to address vulnerabilities.

### **Seismic Vulnerability of Tunnels with LRT**

(Issue D, Importance – Medium)

Placing light rail in the west tunnel or other structures in the corridor does not change the seismic vulnerability. However to protect the large investment the East Link Project represents, the Independent Review Team recommends that seismic vulnerability be assessed, and that a consistent seismic design criteria for the west approach tunnel and all other existing structures in the project be considered.

**Resolution:** Sound Transit and WSDOT agreed that seismic vulnerability studies will be undertaken as an early-start preliminary engineering activity. Retrofit strategies and associated cost estimates will then be developed during preliminary design to address these vulnerabilities.

### **MISCELLANEOUS (ISSUES B, I, J, L, S, V)**

#### **Technical Terms**

*Torsional Moment Capacity:* A twisting action limit on a structural member.

*Median Barrier:* The concrete barrier that separates the existing westbound and reversible lanes at the center of the existing bridge.

*Operational Restrictions (Storms):* Limits placed on the operation of LRT during storms (due to wind or wave action on the floating bridge).

*Anchor Cables:* The woven steel cables that anchor the floating bridge to the anchors embedded in the lake bottom.

### **Operational Restrictions**

(Issue B, Importance – Medium)

Operational restrictions for combination of train loading and one-year storm loading from north should be addressed.

**Resolution:** Based on the Independent Review Team preliminary investigation, this issue does not represent a severe operational limitation on LRT.

### **Torsional Capacity**

(Issue I, Importance – High)

Previous studies have indicated that the operational level bridge global torsional moment demand was very close to the allowable torsional moment capacity. Analysis should be performed to confirm torsional capacity of the existing bridge.

**Resolution:** Independent calculations by the IRT indicate that the torsional capacity of the floating bridge is adequate for the application of LRT loads and a 1-year storm from the north. However, more load combinations need to be analyzed as part of the final design process.

### **North Wind Storm Effects**

(Issue J, Importance – Medium)

The analysis of "North Wind" storm effects on Homer M. Hadley Floating Bridge should be considered.

**Resolution:** The Independent Review Team has performed preliminary analysis for the 1-year north storm event. The preliminary analysis indicates that a storm from the north would produce lower seas (and loads) than the storm from the south used in the previous assessment. The existing Lacey V. Morrow Floating bridge acts as a shelter for storms approaching the Homer M. Hadley Floating Bridge from the south.

### **Operation/Maintenance Coordination between Sound Transit and WSDOT**

(Issue L, Importance – Medium)

The bridge will become a shared asset of Sound Transit and Washington State DOT following the placement of LRT and, therefore, an operation and maintenance coordination agreement between Sound Transit and Washington State DOT is necessary.

**Resolution:** Washington State DOT and Sound Transit have provided documentation acceptable to the Independent Review Team that outlines development, review, and approval of a Sound Transit/Washington State DOT Operation and Maintenance Agreement for the Homer M. Hadley Bridge.

### **Effects of Median Barrier Relocation**

(Issue S, Importance – High)

Measure R-8A proposes that the median barrier be relocated two feet to the south, which require attachment of the new barrier, and may present maintenance and drainage issues.

**Resolution:** Sound Transit provided three preliminary design concepts for relocation of the barrier. Sound Transit and Washington State DOT propose to study the three alternatives, as well as a “no move” alternative to determine the optimum solution. The Independent Review Team recommends that every effort be made to avoid relocation of the existing median.

### **Impact of LRT Installation on Anchor Cable Replacement**

(Issue V, Importance – Low)

Currently, Washington State DOT uses barge cranes to facilitate replacement of anchor cables. This could pose an operation and safety issue when LRT is placed on the bridge. Therefore, the effect of LRT installation on construction operations associated with anchor cable replacement should be addressed.

**Resolution:** Based on discussion with floating bridge construction experts, the IRT determined that anchor cable replacement can be performed without impact to LRT operations, safety, or cost of anchor cable replacement.

### **CONCLUSION**

Based on extensive study, analysis, and discussions with Sound Transit and WSDOT, the IRT has concluded that all issues associated with the installation of LRT on the Homer Hadley Floating Bridge and approach spans can be addressed or mitigated, providing that the IRT resolutions and recommendations are incorporated. However, several issues could affect project cost estimates and schedules and therefore should be resolved at the earliest stages of the project design. One issue, A, deals with a required design element (LRT Expansion Joint Track Bridge) that has no history of use on floating bridges, and therefore requires careful study and testing in the early stages of the project.

Since many of the issues require additional study, analysis, and design, the IRT recommends that an independent review or peer review panel be organized to provide oversight throughout the LRT East Link design process.

**Note:** See the following appendices for a more detailed and technical discussion of all issues, including technical memos that summarize all analyses performed by the IRT.

### **Appendices**

A – Issue Resolution Report

B – Technical Memoranda

C – Meeting Notes

D – Reference Reports

The Independent Review Team concludes that all issues identified as impacting LRT installation can be addressed or mitigated.

# I-90 HOMER HADLEY FLOATING BRIDGE

## Independent Review Team - Light Rail Train Impacts



## *APPENDIX A: ISSUES REPORT*

**SC SOLUTIONS** In Association with

 **THE GLOSTEN ASSOCIATES**  
Consulting Engineers Serving the Marine Community

 **RUSSELL CORROSION CONSULTANTS, INC.**  
Columbia, Maryland  
Garden City, New York

 **CONCORR, Inc.**  
CONCRETE CORROSION SPECIALISTS





# Issue Resolution Report

**Title:**

Washington State Legislature, Joint Transportation Committee  
Independent Review Team  
Feasibility of Placing LRT on the Homer M. Hadley Floating Bridge

**Rev: Page:**

1 of 42

<b>Issue Resolution Report</b>		
<b>Title: Appendix A</b>		
Washington State Legislature, Joint Transportation Committee Independent Review Team Feasibility of Placing LRT on the Homer M. Hadley Floating Bridge		
<p><b>Prepared for:</b></p> <p><b>Washington State Legislature Joint Transportation Committee</b></p> <p><b>September 15, 2008</b></p> <p><b>Prepared by:</b></p>		
Tom Ballard Chuck Ruth, S.E.	SC Solutions, Inc. Lacey, WA	
J. Thomas Bringloe, P.E.	The Glostén Associates Seattle, WA	
Steve Nikolakakos, P.E.	Russell Corrosion Consultants, Inc Garden City, NY	
Ali Akbar Sohangpurwala	CONCORR, Inc. Sterling, VA	

# Issue Resolution Report

## Title:

Washington State Legislature, Joint Transportation Committee  
Independent Review Team  
Feasibility of Placing LRT on the Homer M. Hadley Floating Bridge

## Rev:

## Page:

2 of 42

## Table of Contents

1.	Introduction.....	3
2.	Purpose and Scope of Independent Review .....	4
3.	Definition and Classification of Issues.....	6
Issue A	Track Bridge/Expansion Joint Design and Performance Criteria .....	7
Issue B	Operational Restrictions for Combination of Train Loading and One-year Storm Loading from North .....	9
Issue C	Seismic Vulnerability and Seismic Retrofit of Approach Spans and Transition Span .....	10
Issue D	West Approach Tunnel Design Criteria Consistency .....	12
Issue E	Need for Lightning Arrestors on Floating Bridge and Approaches .....	13
Issue F	Sound Transit Adoption of North Link/Airport Link Stray Current Mitigation Design Criteria for Homer M. Hadley Floating Bridge Installation .....	15
Issue G	Impact of Stray Current Dispersion in Lake Washington on Environment and Fish.....	18
Issue H	Stray Current and Cathodic Protection System Interference and Compatibility.....	19
Issue I	Analysis to Confirm Torsional Capacity of the Existing Bridge.....	21
Tech Memo:		
Issue J	Analysis "North Wind" Storm Effects on Homer M. Hadley Floating Bridge .....	22
Issue K	Criteria Established for Independent Review Team to Evaluate Numerous Issues .....	24
Issue L	Operation and Maintenance Coordination Agreement between Sound Transit and Washington State DOT .....	25
Issue M	Rider Comfort Performance for LRT Track Bridge at Expansion Joints .....	26
Issue N	Attachment of OCS Supports to Edge of Homer M. Hadley Floating Bridge Deck Cantilevers.....	28
Issue O	Methods to be Utilized for Locating Rebar and Post Tensioning in Bridge Deck.....	30
Issue P	Determining Strength and Electrical Resistance of Existing Concrete .....	32
Issue Q	Modification of Current Bridge Inspection Procedures if LRT Approved .....	33
Issue R	Storm water Drainage System Modifications under New LRT Track Bridge at Expansion Joints.....	35
Issue S	Median Barrier Relocation Design, Attachment, Maintenance and Drainage.....	36
Issue T	Washington State DOT's and Sound Transit's Goal for Life Expectancy of Bridge .....	37
Issue U	Method for Identifying Stray Current Failure and Response/Repair Plan .....	38
Issue V	Effect of LRT Installation on Construction Operations Associated With Anchor Cable Replacement .....	40
Issue W	Additional Needs and Changes Required for LRT Installation to meet "Blue Ribbon Panel" Recommendations .....	41
Conclusion.....		41



# Issue Resolution Report

**Title:**

Washington State Legislature, Joint Transportation Committee  
Independent Review Team  
Feasibility of Placing LRT on the Homer M. Hadley Floating Bridge

**Rev:****Page:**

3 of 42

## General

The purpose of this independent review is to evaluate the original bridge analysis, studies, and tests, to determine the impacts associated with installation and operation of LRT on the Homer M. Hadley Floating Bridge. Supplemental analysis was also performed by the IRT. While there are similar installations of light rail across suspension bridges, there is no precedent for installing light rail across a floating bridge. This report identifies LRT installation impact issues and outlines recommendations and resolution for each issue.

### 1. Introduction

The central Puget Sound region is home to Fortune 500 corporations such as Microsoft, Boeing and Starbucks, while serving as a primary gateway for the movement of goods to and from East Asian markets through its world class ports and terminal facilities. The region has only two transportation facilities crossing Lake Washington: I-90 and SR 520 Floating Bridges. The Puget Sound area is faced with a growing population and increased congestion on these key regional links. The Central Puget Sound region has a steadily growing population with an estimated 3.5 million people in 2005 and is projected to grow to over 4.6 million by 2030 with notable growth assumed on the east side of Lake Washington.

For the I-90 Corridor, past studies and regional agreements have identified I-90 as the preferred corridor for high capacity transit, light rail. The I-90 roadway and floating bridges link the City of Seattle with the island community of Mercer Island and communities on the east side of Lake Washington such as Bellevue and Issaquah with I-90 serving as the only connection between Mercer Island and the mainland. During an average weekday the I-90 roadway carries approximately 133,000 vehicles per day. It is for these reasons that Sound Transit is proposing the corridor to accommodate high capacity transit in the form of light rail across the I-90 floating bridge.

The Homer M. Hadley Floating Bridge was designed in the early 1980s. The design for the bridge was supported by the 1976 Memorandum Agreement signed by communities and jurisdictions along the I-90 corridor to support the development of high capacity transit in the center roadway of the Homer M. Hadley Floating Bridge. As part of the bridge design process, the design included analysis of the bridge for light rail (LRT) which had design characteristics similar to the current Sound Transit LRT loading standards. This previous analysis assumed that the center roadway HOV (South side) lanes would be converted to LRT.

Beginning in 2001 studies and tests were re-initiated to evaluate the effects of LRT on the floating bridge utilizing current Sound Transit LRT loads. These structural feasibility studies, performed by Washington State DOT consultants, assessed placing LRT in the center roadway and adding an HOV lane to the outer westbound roadway (R-8A scenario). The analysis showed LRT conversion modifications were structurally feasible with weight mitigation measures on the bridge and limitations on track system weight.

In 2005, fully loaded large trucks were run across the Homer M. Hadley Bridge to simulate an LRT system based on current Sound Transit train and track standards. The bridge was fully

# Issue Resolution Report

**Title:**

Washington State Legislature, Joint Transportation Committee  
Independent Review Team  
Feasibility of Placing LRT on the Homer M. Hadley Floating Bridge

**Rev: Page:**

4 of 42

instrumented to record pontoon deflections and stresses during the test. The data from the load test demonstrated close correlation to the computer model used in earlier studies with minor modifications. LRT loads were combined with original design load combinations like wind, wave, temperature, dead load and pre-stress.

The analysis showed that live loading (obtained by creating the live load envelopes including two-four-car crush loaded LRV and three lanes of HS25 highway loading) combined with the 1-year storm loads, from the south, produced demands that were 97% of the allowable stresses becoming the controlling case for operational limitations of LRT. The allowable stress criteria protect the bridge from fatigue. This calculation also ignored the shielding effect providing by the Lacy V, Murrow Bridge to storms from the south.

In 2006, Governor Christine Gregoire reaffirmed the State's previous commitment to dedicate the center roadway to light rail or light rail convertible bus rapid transit. During this year, the Sound Transit Board also identified light rail as the preferred mode for high capacity transit across the I-90 Bridge.

During summer and fall 2007, Sound Transit prepared preliminary concept studies for:

- Rail Expansion Joints Across The Transition Spans Joints
- LRT-Induced Vibrations
- Overhead Contact System (OCS)
- Stray Current Issues (Structures and Utilities)
- Instrumentation of Transition Spans Joints For Current In-Service Motions

Sound Transit intends to expand structural analysis of light rail and mitigation to the Homer M. Hadley Bridge during the design phase of East Link, following the funding of the project.

## 2. Purpose and Scope of Independent Review

The purpose of the independent review is to evaluate the original bridge analysis, subsequent studies, tests, and preliminary concept studies to determine the impacts to install and operate LRT on the Homer M. Hadley Floating Bridge. While there are similar developments of light rail across suspension bridges, there is no precedent in the world for implementing light rail across a floating bridge. The East Link project is currently in the environmental review and conceptual design phase with preliminary engineering anticipated to start in 2009, final design anticipated to start in 2011 and revenue operation in 2020, assuming approval of an ST2 plan with East Link funding.

The following elements were addressed as part of the independent review:

1. Review Sound Transit conceptual proposals for stray current mitigation, recommend areas of further investigation, and design milestones through preliminary engineering and final design. Specifically, review of designs for isolating stray current that avoids corrosion of the steel reinforcing and other metal elements of the existing floating bridge and transition spans.

# Issue Resolution Report

## Title:

Washington State Legislature, Joint Transportation Committee  
Independent Review Team  
Feasibility of Placing LRT on the Homer M. Hadley Floating Bridge

Rev: Page:

5 of 42

2. Review Sound Transit standard directive drawings for the light rail track and power system. Review and recommend design approaches for attaching the LRT track system (including OCS poles, plinths and track fasteners, and safety rails) to the pontoon, elevated roadway, and transition span decks that maintains the reinforcing steel, post-tensioning cables, other metallic embeds; and limits existing concrete installation damage to an acceptable levels.
3. Review the previous load test data, perform preliminary analysis as required to evaluate structural feasibility, and recommend any additional analysis needed to determine the operational “storm” limitation on the floating bridge in combination with LRT dead and live loads. Assess weight mitigation measures for sufficiency.
4. Assess impact of weight mitigation measures on bridge life, effects of LRT track system on existing maintenance and operations policies, recommend new policies, maintenance criteria and potential work force and cost increases needed to accommodate LRT beyond existing bridge maintenance practices and budget, and recommend any additional analysis.
5. Identify the effects (including eccentricity) of the LRT dead/live loads and rails on the transition spans expansion joints, bridge decks, and other bridge elements and make recommendations for design criteria.
6. Review the proposed rail expansion joint design and provide any additional comment or suggestions to accommodate anticipated joint movements and any associated modifications to the bridge.

Although not part of this independent review, the stakeholders (Joint Transportation Committee, Washington State DOT and Sound Transit) should assess the cost associated with “risk” of earlier loss and reconstruction of the Homer M. Hadley Floating Bridge and approaches than expected remaining life. There are several elements, such as stray current and corrosion, associated with placing LRT on the Homer M. Hadley Floating Bridge that require careful attention during design to avoid reducing the remaining life of the bridge. To adequately assess the risk of the potential loss of bridge and/or reduced remaining life, all stakeholders need to understand the costs associated with loss of this facility. The risk can be defined in terms of cost as follows:

- Time required to redesign bridge and approaches and associated cost
- Time required to reconstruct a new floating bridge and approaches and associated cost
- The economic impact costs associated with the total time identified in items 1 & 2
- The total cost impacts associated with items 1, 2, & 3.

Having this risk information should put the importance of each issue in proper perspective. This is considered an important issue when considering the cost of design measures to mitigate impacts and protect the useful life of the floating bridge. However, from an engineering standpoint, this will not affect the feasibility of placing LRT on the bridge.

# Issue Resolution Report

**Title:**

Washington State Legislature, Joint Transportation Committee  
Independent Review Team  
Feasibility of Placing LRT on the Homer M. Hadley Floating Bridge

**Rev: Page:**

6 of 42

### 3. Definition and Classification of Issues

This report identifies, tracks, and provides resolution to the issues that impact placement of the LRT on the Homer M. Hadley Floating Bridge. Sound Transit and WSDOT provided responses to these issues, and resolution is documented in this report. The issue importance definitions in Table 1 have been adopted as part of this independent review assessment.

**Table 1: Definition of Importance of Each Issue to the Feasibility Study**

<b>Importance of Issue</b>	<b>Definition</b>
<b>High</b>	These issues have the potential to have a major installation impact or represent a potential major cost impact to the East Link Project. An action plan was developed by Sound Transit and/or Washington State DOT to address these issues during concept studies and before preliminary design is started.
<b>Medium</b>	These issues will most likely not have a major impact on installing LRT on the Homer M. Hadley floating bridge, but should be resolved before preliminary design is complete and final design proceeds. These are important issues identified by the Independent Review Team, but ones that can be mitigated or addressed. An action plan was developed by Sound Transit and/or Washington State DOT to address these issues during preliminary design.
<b>Low</b>	These issues are important, but will have no significant impact on LRT installation. This issue can be resolved during the final design, but before construction begins.

Following is a summary of each issue along with resolution and IRT recommendations. Appendix A of this report contains additional information regarding the definition of the issues and references to analysis performed by the IRT (See Appendix B, Tech Memos).

# Issue Resolution Report

**Title:**

Washington State Legislature, Joint Transportation Committee  
 Independent Review Team  
 Feasibility of Placing LRT on the Homer M. Hadley Floating Bridge

**Rev: Page:**

7 of 42

<b>Issue A Track Bridge/Expansion Joint Design and Performance Criteria</b>		
<b>Independent Review Team Member Responsible for Resolution of Issue</b>	<b>Importance of Issue</b>	<b>Agency Responsible for Providing Resolution</b>
Chuck Ruth	High	Sound Transit
<b>General Description and Background of Issue</b>		
<p>The feasibility of connecting the East Link light rail line to the Central Link requires that the track bridge, at each end of the transition spans, be functional at all times during operation. The Independent Review Team acquired the design/performance criteria used by Washington State DOT for the new expansion joints that they are placing in the Homer M. Hadley Floating Bridge. These criteria should be a good basis for outlining the performance specification for the track bridge at the expansion joints. Early prototype testing is recommended because the track bridge is unique.</p> <p>The Independent Review Team is not aware of any current manufactured track bridge concept that could be adopted for the use on the floating bridge. Sound Transit has developed and provided the Independent Review Team with conceptual details for the proposed track bridge. Since the successful installation and operation of the track bridge is a critical element for East Link and a unique design, the track bridge concept needs to be developed and prototype testing performed before final design begins. Track bridge noise should also be evaluated as part of the prototype testing. The track bridge attachments and effects on the supporting structure require testing as well.</p>		
<b>Required Information for Independent Review Team's Review</b>		
<ul style="list-style-type: none"> <li>• Design and performance criteria for new expansion joint from Washington State DOT.</li> <li>• Prototype development and test plan for track bridge.</li> <li>• Method for production track bridge testing.</li> <li>• Proposed approach for incorporation of track bridge into final contract (agency-furnished contract element or contractor-fabricated element).</li> </ul>		
<b>Data Sources and Documents Provided by Responsible Agency</b>		
<ol style="list-style-type: none"> <li>1. INCA Engineers, Inc., "Eastside HCT Corridor, I-90 floating Bridge (Homer Hadley), Expansion Joint Final Conceptual Report, January 2008.</li> <li>2. May 30th, 2008 letter from Sound Transit in response to the Independent Review Team's April 24, 2008 letter.</li> </ol>		

# Issue Resolution Report

**Title:**

Washington State Legislature, Joint Transportation Committee  
Independent Review Team  
Feasibility of Placing LRT on the Homer M. Hadley Floating Bridge

**Rev: Page:**

8 of 42

## Resolution of Issue

Prototype testing and vetting of the track bridge concept design needs to be performed as soon as possible. This type of track bridge has never been utilized before and there is no historical data available for Independent Review Team to judge the feasibility of this concept. Therefore, the Independent Review Team recommends the following action plan for track bridge:

- Perform preliminary design of the track bridge system based on Washington State DOT-accepted design criteria for the following two load conditions: (1) LRT max load in combination with “normal operating conditions” (to be established based on nominal bridge storm movement and maximum lake level drop or rise, with appropriate load factors), and (2) extreme (maximum operational level storm movement) in combination with max LRT load (up to yield material stress allowed with no load factors). Preliminary and final design of the track bridge system should be completed prior to prototype testing.
- Based on member sizes, connections, bridge rail elements, and fasteners determined from preliminary design, fabricate a “prototype” track bridge and test in accordance with Washington State DOT fatigue testing requirements for major bridge expansion joints. Prototype testing should include provisions maintenance, removal, and replacement of the track bridges. The sound emitted by the track bridge under LRT loading should be monitored throughout testing to assure that acceptable sound levels are not exceeded. Prototype fabrication and testing should be completed prior to the start of final design of the LRT installation.
- Modify track bridge design based on results of prototype testing and perform additional testing until it is determined that the final prototype will function with tolerable maintenance for the anticipated remaining life of the bridge or until scheduled replacement milestones. This stage should be completed at least two years before the anticipated final LTR installation contract on the Homer Hadley Floating Bridge, and before any construction begins on the East/West LRT Link.
- Consider fabricating track bridges prior to final contract for placing LRT on Homer Hadley Floating Bridge. Fabrication would include development of a “track bridge maintenance manual” and at least one extra replacement track bridge.
- Consider installing track bridges in final LRT contract as “agency-furnished materials”

Preliminary analysis by the Independent Review Team indicates that the Sound Transit conceptual design track bridge member stresses are within reasonable limits under the application of LRT loads (see Appendix B, Technical Memorandum TM-03 Expansion Joint Model).

# Issue Resolution Report

**Title:**

Washington State Legislature, Joint Transportation Committee  
 Independent Review Team  
 Feasibility of Placing LRT on the Homer M. Hadley Floating Bridge

**Rev: Page:**

9 of 42

<b>Issue B Operational Restrictions for Combination of Train Loading and One-year Storm Loading from North</b>		
<b>Independent Review Team Member Responsible for Resolution of Issue</b>	<b>Importance of Issue</b>	<b>Agency Responsible for Providing Resolution</b>
Tom Bringloe	Medium	Washington State DOT and Sound Transit
<b>General Description and Background of Issue</b>		
<p>Earlier studies by KPFF concluded combined live load from two four-car crush-load trains plus three lanes of HS25 highway loading plus a one-year recurrence storm from the south would load the bridge to 97% of its operational capacity in torsion. The storm demand will be verified (Issue J). The train live load demand will be reviewed, but has been validated by full scale experiments.</p>		
<b>Required Information for Independent Review Team’s Review</b>		
<p>All required information is in hand to address this issue.</p>		
<b>Data Sources and Documents Provided by Responsible Agency</b>		
<p> </p>		
<b>Resolution of Issue</b>		
<p>Based on the Independent Review Team preliminary investigation, this issue does not represent a significant operational limitation on LRT (see Appendix B, Technical Memorandum TM-02 Torsional Analysis).</p>		

# Issue Resolution Report

**Title:**

Washington State Legislature, Joint Transportation Committee  
 Independent Review Team  
 Feasibility of Placing LRT on the Homer M. Hadley Floating Bridge

**Rev: Page:**

10 of 42

<b>Issue C Seismic Vulnerability and Seismic Retrofit of Approach Spans and Transition Span</b>		
<b>Independent Review Team Member Responsible for Resolution of Issue</b>	<b>Importance of Issue</b>	<b>Agency Responsible for Providing Resolution</b>
Tom Ballard	High	Washington State DOT and Sound Transit
<b>General Description and Background of Issue</b>		
<p>The Homer M. Hadley Floating Bridge approaches and transition span were designed based on ATC-6 detailing requirements and a 475-yr return period earthquake.</p> <p>The Sound Transit Design Criteria Manual for the North Link and Airport Link states that structures owned and operated by local agencies (Washington State DOT, cities and counties) shall be designed by the codes adopted by the local agency and jurisdiction. Beginning in 2008, Washington State DOT adopted a new seismic retrofit policy for bridges using a 1000-year return period earthquake in combination with a of the no-collapse damage limit.</p> <p>Since the bridge is the only link between the Central Link and East Link lines, the level of seismic risk and performance goals for the structure should be evaluated in a consistent manner with the rest of the East Link project. The Homer M. Hadley bridge remaining life should first be determined (Issue T).</p> <p>This issue is not considered to be critical to the feasibility of placing the LRT on the bridge; however, it does represent a potentially a design and construction cost impact to the project and should be addressed before final design can proceed.</p>		
<b>Required Information for Independent Review Team’s Review</b>		
<p>Two aspects of the seismic vulnerability and retrofit feasibility should be addressed:</p> <ul style="list-style-type: none"> <li>• The vulnerability of the approach spans to the acceleration ground motions. This should be assessed with a response spectrum demand analysis and push-over capacity analysis. It should be noted that the Sound Transit design criteria for new aerial structures requires that the inertia effects of a LRV on a single track, without impact, be considered along with the design earthquake loads. These criteria results from the fact that Sound Transit has aerial structures that are several miles long which increases the probability of having the LRV on an aerial structure during a seismic event. Strategies that address this vulnerability should be presented and their feasibility should be discussed.</li> <li>• The vulnerability of the transition spans, pivot pins and bearings to the acceleration ground motions and the maximum horizontal and vertical ground displacements. For this analysis, response modification factors should not be greater than one. Strategies that address this vulnerability should be presented and their feasibility should be discussed.</li> </ul>		



# Issue Resolution Report

**Title:**

Washington State Legislature, Joint Transportation Committee  
Independent Review Team  
Feasibility of Placing LRT on the Homer M. Hadley Floating Bridge

**Rev: Page:**

11 of 42

## Data Sources and Documents Provided by Responsible Agency

1. INCA Engineers, Inc., "Eastside HCT Corridor, I-90 floating Bridge, Seismic Vulnerability Study, Final Conceptual Report, January 2008.
2. May 30th, 2008 letter from Sound Transit in response to the Independent Review Team's April 24, 2008 letter.
3. INCA Engineers, Inc., Sound Transit East Link Phase 2 Project – IRT ISSUE C – Seismic Vulnerability and Seismic Retrofit of Approach Spans and Transition Span, June 13, 2008

## Resolution of Issue

It appears that the design of the approach structures met the seismic requirements at the time of construction in the early 1980s. Considering the importance of the structure to transit and general purpose traffic, current AASHTO seismic retrofit standards should be applied, which will likely result in significant retrofit costs. WSDOT and Sound Transit have determined that the Homer Hadley Floating Bridge and approach spans that support LRT should meet the requirements of current AASHTO bridge standards (1000 year return period).

The Independent Review Team performed a preliminary seismic vulnerability study on the west approach spans for the 1000 year event (see Appendix B, Technical Memorandum TM-05 Seismic Vulnerability Assessment of the West Approach and Transition Spans). Preliminary analysis by the IRT indicates that significant retrofit will likely be required for the approach spans. The IRT recommends that both approach span alignments be considered for retrofit due to the proximity of the two structures to each other (for example, one over the top of the other at the east portal of the Mount Baker Ridge Tunnel). WSDOT and Sound Transit have agreed that detailed seismic vulnerability studies will be undertaken as an early-start Preliminary Engineering activity. Retrofit strategies and associated construction costs should then be developed during preliminary design to address any identified vulnerabilities and determine project cost impacts.

# Issue Resolution Report

**Title:**

Washington State Legislature, Joint Transportation Committee  
 Independent Review Team  
 Feasibility of Placing LRT on the Homer M. Hadley Floating Bridge

**Rev: Page:**

12 of 42

<b>Issue D West Approach Tunnel Design Criteria Consistency</b>		
<b>Independent Review Team Member Responsible for Resolution of Issue</b>	<b>Importance of Issue</b>	<b>Agency Responsible for Providing Resolution</b>
Tom Ballard	Medium	Sound Transit
<b>General Description and Background of Issue</b>		
<p>Although the West Approach Tunnel is not the responsibility and therefore not the focus of the Independent Review Team, the tunnel at the western approach to the Homer M. Hadley Floating Bridge is a critical structural element in the East Link Project. The Sound Transit Design Criteria Manual for the North Link and Airport Link states that structures owned and operated by local agencies (Washington State DOT, cities and counties) shall be designed by the codes adopted by the local agency and jurisdiction. However, Washington State DOT does not currently have seismic retrofit policies for tunnel structures.</p> <p>This tunnel is also an existing Washington State DOT structure and is therefore similar to the situation with the approach and transition spans. The design criteria for the tunnel should therefore be aligned with the design criteria for the approach and transition spans to the floating bridge. A consistent level of risk should be specified for all structures making up this link. This issue does not affect the feasibility of placing the LRT on the bridge; however, it is important for developing consistent design criteria for the East Link project and therefore should be resolved before final design begins.</p>		
<b>Required Information for Independent Review Team’s Review</b>		
<p>Verification from Sound Transit and Washington State DOT that this issue will be addressed as part of the design process.</p>		
<b>Data Sources and Documents Provided by Responsible Agency</b>		
<ol style="list-style-type: none"> <li>1. Parsons, “East Link Project, Ventilation Analysis of Existing I-90 Tunnels, Mount Baker and First Hill Tunnels, Final Draft Report, August 2007.</li> <li>2. May 30th, 2008 letter from Sound Transit in response to the Independent Review Team’s April 24, 2008 letter.</li> </ol>		
<b>Resolution of Issue</b>		
<p>Although this issue is not an impact issue, given that the vulnerability of this structure affects the risk of East Link down time as well as the general purpose traffic in the upper tunnel level, the Independent Review Team recommends that Washington State DOT and Sound Transit perform a full seismic vulnerability study of all existing structures that will be used for LRT before preliminary design.</p>		

# Issue Resolution Report

**Title:**

Washington State Legislature, Joint Transportation Committee  
 Independent Review Team  
 Feasibility of Placing LRT on the Homer M. Hadley Floating Bridge

**Rev: Page:**

13 of 42

<b>Issue E Need for Lightning Arrestors on Floating Bridge and Approaches</b>		
<b>Independent Review Team Member Responsible for Resolution of Issue</b>	<b>Importance of Issue</b>	<b>Agency Responsible for Providing Resolution</b>
Steve Nikolakakos	Medium	Sound Transit
<b>General Description and Background of Issue</b>		
<p>Lightning can cause safety hazards and damage to equipment, structures, electrical systems, etc. Lightning protection systems are designed and installed to provide protection against such threats. The systems normally consist of lightning arrestor/rods, down conductors and ground electrodes. The Sound Transit "North Link and Airport Link Design Criteria Manual provide general guidelines for Lightning Protection and Grounding. The Independent Review Team requests additional details to be able to evaluate the adequacy of the system for the approach structures and the Homer M. Hadley Floating Bridge.</p> <p>It is assumed that the lightning protection system will be designed during the final design of the project. It is important that the lightning protection system be designed and installed to minimize structural damage to the pontoon walls, approach structures, pier foundations, and provide protection to the traction power system and personnel/public. It should be noted that although lightning storms do not occur very often in the Pacific Northwest, compared to other areas of the United States, they do represent a risk.</p>		
<b>Required Information for Independent Review Team's Review</b>		
<p>Detailed lightning/grounding protection criteria. The issue on design criteria is also raised in Issue K. The final design criteria should include:</p> <ul style="list-style-type: none"> <li>• Structures/equipment to be provided with lightning arrestors/rods.</li> <li>• Down conductor (description).</li> <li>• Ground electrode (description and location).</li> </ul>		
<b>Data Sources and Documents Provided by Responsible Agency</b>		
<p>General comments on the lightning protection system for OCS poles were provided to Sue Comis (Sound Transit) from Roger Koester (Parsons) in an e-mail dated April 29, 2008.</p> <ol style="list-style-type: none"> <li>1. Sound Transit "North Link and Airport Link Design Criteria Manual" dated November 2005.</li> <li>2. Lightning Protection Code, NFPA No. 780</li> <li>3. Master Labeled Lightning Protection System, UL 96A.</li> <li>4. May 30th, 2008 letter from Sound Transit in response to the Independent Review Team's April 24, 2008 letter.</li> </ol>		

# Issue Resolution Report

**Title:**

Washington State Legislature, Joint Transportation Committee  
Independent Review Team  
Feasibility of Placing LRT on the Homer M. Hadley Floating Bridge

**Rev:    Page:**

14 of 42

## Resolution of Issue

Sound Transit has indicated that lightning protection system will be designed for the floating bridge.

Based on the review of the proposed lightening protection system, the Independent Review Team recommends the following:

- The conductors and ground electrodes are not to be connected to the stray current conductors and ground electrodes (this will minimize stray current from discharging from the OCS support plates on the pontoon walls).
- The OCS support plates and bolts are to be electrically isolated from the concrete walls of the pontoons (this will minimize possible damage to the wall from lightning discharges).

# Issue Resolution Report

**Title:**

Washington State Legislature, Joint Transportation Committee  
 Independent Review Team  
 Feasibility of Placing LRT on the Homer M. Hadley Floating Bridge

**Rev: Page:**

15 of 42

<b>Issue F Sound Transit Adoption of North Link/Airport Link Stray Current Mitigation Design Criteria for Homer M. Hadley Floating Bridge Installation</b>		
<b>Independent Review Team Member Responsible for Resolution of Issue</b>	<b>Importance of Issue</b>	<b>Agency Responsible for Providing Resolution</b>
Steve Nikolakakos	High	Sound Transit
<b>General Description and Background of Issue</b>		
<p>The Sound Transit “North Link and Airport Link Design Criteria Manual provide stray current control guidelines under Section 17.3 of the manual. The guidelines, even though do not specifically refer to the Homer M. Hadley floating bridge, they provide criteria for stray current corrosion control for different transit fixed facilities. For facilities with direct fixation rails the criteria for stray current corrosion control include:</p> <ul style="list-style-type: none"> <li>• Electrical continuity of the top layer of the reinforcing steel or a wire mesh current collector mat.</li> <li>• Ground electrode system.</li> <li>• Test facilities</li> </ul> <p>Such stray current corrosion control systems are designed to collect the stray current and discharged it to earth/water through the ground electrodes. These systems will minimize/prevent stray current corrosion of support reinforced concrete structures.</p> <p>Sound Transit’s primary approach to stray current corrosion control is to minimize the stray current by lowering the return circuit resistance, increasing the track to earth resistance, and frequently monitoring the stray current of the system. The Independent Review Team reviewed the preliminary stray current information provided by Sound Transit and requested additional information.</p>		
<b>Required Information for Independent Review Team’s Review</b>		
<p>The information below was required, by Independent Review Team, to evaluate the overall stray current effects on the structures and determine, based on the calculation/assumptions made, if the proposed design (including the use of stray current collection mats, ground electrodes and monitoring systems) assumes an increased level of risk.</p> <ul style="list-style-type: none"> <li>• Stray current calculations.</li> <li>• Track-to-earth resistance under different weather conditions.</li> <li>• Stray current variations due to changes in track-to-earth resistance.</li> <li>• The monitoring of stray current and estimated time to identify and repair/replace failed fasteners.</li> <li>• Preliminary design details of stray current corrosion control system components (to</li> </ul>		

# Issue Resolution Report

**Title:**

Washington State Legislature, Joint Transportation Committee  
Independent Review Team  
Feasibility of Placing LRT on the Homer M. Hadley Floating Bridge

**Rev: Page:**

16 of 42

collect and discharge the stray current).

- The process for identifying and repairing failed components of the system that would increase the stray current.

### Data Sources and Documents Provided by Responsible Agency

1. Sound Transit "North Link and Airport Link Design Criteria Manual" dated November 2005. "
2. Stray Current Analysis Report - Draft" Dated August 31, 2007. Prepared by Sound Transit East Link Project Team
3. Data Sheet for Stray Current Calculations: Sound Transit I-90 Bridge Feasibility dated May 20, 2008.
4. May 30th, 2008 letter from Sound Transit in response to the Independent Review Team's April 24, 2008 letter.
5. Sound Transit East Link Project – Issue Resolution Report – Support Data; June 13, 2008

### Resolution of Issue

Sound Transit has agreed to utilize more stringent design criteria for stray current analysis. They have also agreed to provide collection mats with ground electrodes to dissipate stray current and provide stray current monitoring system. These measures (if properly implemented, monitored and maintained) should protect the useful life of the floating bridge.

The Independent Review Team recommends, based on the review of various stray current documents, that the following be included in the final design calculations:

- The resistance of the rails applied in calculations should be greater than the actual resistance of the final configuration for the negative return.
- Field testing on other transit systems shows that a wide range of resistance values for in-service rail fasteners can occur depending on the mode of deterioration. The track-to-earth resistance calculations, for the life of the project, should reflect degradation of the insulating characteristics of the rail fasteners with time. The results of these calculations should be included in the overall stray current analysis including metal loss calculations.
- The failure mode calculations should consider worst case and intermediate case scenarios. The metal loss calculations should also consider potential failures of the stray current collector mat. The worst case scenarios should include failures of the fastener insulation and collector mat. The results of such an evaluation should define the risks and the requirements for timely repairs. All assumptions made and formulas used in the calculations should be supported by references.

# Issue Resolution Report

**Title:**

Washington State Legislature, Joint Transportation Committee  
Independent Review Team  
Feasibility of Placing LRT on the Homer M. Hadley Floating Bridge

**Rev:    Page:**

17 of 42

The Independent Review Team also makes the following design recommendations:

- The top steel reinforcement layer of the deck and possibly the transverse post tension cables in the deck under the rails may not be electrically continuous. These steel components could be affected by the stray current and therefore the stray current mitigation system that Sound Transit proposes to design and install must be capable to collect most of the stray current. In addition, the monitoring system must initiate an alarm when increased levels of stray current are detected or a stray current collector mat has failed. The cause of such alarms must be investigated and corrected in a short period of time.
- The proposed upgraded cathodic protection system will provide backup stray current protection to the underwater steel reinforcing of the pontoons and anchor cables. It would not, however, provide any stray current protection to the top steel reinforcement layer of the deck and the post tension cables in the deck that are assumed not to be electrically continuous. It is therefore important that any failures in fastener insulation and/or collector mats be detected and repaired in a short period of time.
- See Stray Current technical memo by Concorr, Inc., dated August 20, 2008 in Appendix B.

# Issue Resolution Report

**Title:**

Washington State Legislature, Joint Transportation Committee  
 Independent Review Team  
 Feasibility of Placing LRT on the Homer M. Hadley Floating Bridge

**Rev: Page:**

18 of 42

<b>Issue G Impact of Stray Current Dispersion in Lake Washington on Environment and Fish</b>		
<b>Independent Review Team Member Responsible for Resolution of Issue</b>	<b>Importance of Issue</b>	<b>Agency Responsible for Providing Resolution</b>
Chuck Ruth	Low	Sound Transit
<b>General Description and Background of Issue</b>		
<p>There is currently some electrical current dispersion in Lake Washington originating from the existing cathodic protection system. While there is no known impact on fish from this system, the Independent Review Team recommends assessing how stray current levels from the light rail system compare to the existing cathodic protection system and determining whether impacts to fish are possible.</p> <p>The Independent Review Team does not consider this as a critical issue relative to the feasibility of placing the LRT on the bridge. However, it does need to be resolved as part of the environmental approval process and therefore should be addressed before the final design begins.</p>		
<b>Required Information for Independent Review Team’s Review</b>		
An assessment by Sound Transit/ Washington State DOT environmental specialists.		
<b>Data Sources and Documents Provided by Responsible Agency</b>		
<ol style="list-style-type: none"> <li>Herrera Environmental Consultants, Inc., Interstate 90/Homer Hadley Bridge, Light Rail Transit (LRT) Stray Current – Assessment of Potential Effects on Fish, June 13, 2008.</li> </ol>		
<b>Resolution of Issue</b>		
A technical assessment provided by Sound Transit indicates that stray current will not have a significant impact on fish in Lake Washington.		



# Issue Resolution Report

**Title:**

Washington State Legislature, Joint Transportation Committee  
 Independent Review Team  
 Feasibility of Placing LRT on the Homer M. Hadley Floating Bridge

**Rev: Page:**

19 of 42

<b>Issue H Stray Current and Cathodic Protection System Interference and Compatibility</b>		
<b>Independent Review Team Member Responsible for Resolution of Issue</b>	<b>Importance of Issue</b>	<b>Agency Responsible for Providing Resolution</b>
Ali Akbar Sohanghpurwala	High	Washington State DOT and Sound Transit
<b>General Description and Background of Issue</b>		
<p>Cathodic protection systems are presently installed on the Homer M. Hadley and the Lacey V. Murrow Bridges. The original goal of the system was to protect the anchor cables of both bridges, minimize corrosion and reduce the frequency of replacement. The cables of both bridges cross under each other and each system can be expected to interfere with the other systems.</p> <p>The present cathodic protection systems are deficient; many anodes are missing and they are not fully operational. Considering the recent findings by Sound Transit that much of the reinforcement and many of the anchor cables are continuous, it can be expected that some of the cathodic protection current is distributed to the reinforcement in the concrete pontoons. The original system was not designed to provide such protection and therefore, cannot be expected to provide the level of protection originally intended for the anchor cables. Even if Light Rail is not installed on the bridge, the present condition of the system may inadvertently cause corrosion of the anchor cables or reinforcement.</p> <p>If and when stray currents are generated by light rail, they can impact the integrity of the anchor cables and the exterior reinforced concrete elements of the pontoons exposed under water. The cathodic protection systems will then be essential in mitigating corrosion on the cables and the reinforcement in the pontoons. The present system is not capable of performing this function and needs to be upgraded.</p> <p>The stray current from the light rail can also impact the integrity of the anchor cables of the Lacey V. Murrow Bridge as they pass right under the Homer M. Hadley Bridge and therefore, it is necessary the cathodic protection systems on both bridges, the Homer M. Hadley and the Lacey V. Murrow be upgraded and effective monitoring and maintenance procedures be put in place.</p> <p>For the cathodic protection systems to be effective, sufficient resources will have to be devoted to regular monitoring and maintenance. An effective plan for monitoring and maintenance will be needed to ensure that stray current impact is kept to a level that will achieve the desired 100-year bridge life expectancy.</p>		
<b>Required Information for Independent Review Team's Review</b>		

# Issue Resolution Report

**Title:**

Washington State Legislature, Joint Transportation Committee  
Independent Review Team  
Feasibility of Placing LRT on the Homer M. Hadley Floating Bridge

**Rev: Page:**

20 of 42

- Information already exists to address this issue, however, a commitment from Washington State DOT to upgrade, monitor and maintain the cathodic protection systems is required.
- The impact to Washington State DOT of running this system needs to be factored into near term and long term costs associated with this issue.

### **Data Sources and Documents Provided by Responsible Agency**

1. Cathodic Protection Systems Third Lake Washington Bridge, Norton Corrosion Engineers, July 1993.
2. Cathodic Protection Assessment, I-90 Bridges, R. W. Beck & Associates, October 1993
3. In-Depth Cathodic Protection System Inspection and Recommendations, May 2004
4. In-Depth Cathodic Protection System Inspection and Recommendations, May 2006

### **Resolution of Issue**

The Independent Review Team believes that a cathodic protection system provides another layer of defense against environmental and stray currents. Therefore the Independent Review Team recommends the following:

- The cathodic protection systems on the Homer Hadley and the Lacey V. Murrow bridges should be upgraded.
- Resources and plans must be in place to operate, monitor and adequately maintain the cathodic protection systems.

# Issue Resolution Report

**Title:**

Washington State Legislature, Joint Transportation Committee  
 Independent Review Team  
 Feasibility of Placing LRT on the Homer M. Hadley Floating Bridge

**Rev: Page:**

21 of 42

<b>Issue I Analysis to Confirm Torsional Capacity of the Existing Bridge</b>		
<b>Independent Review Team Member Responsible for Resolution of Issue</b>	<b>Importance of Issue</b>	<b>Agency Responsible for Providing Resolution</b>
Tom Ballard	High	Washington State DOT and Sound Transit
<b>General Description and Background of Issue</b>		
<p>The capacity of the floating bridge has been previously computed using classical analysis methods, which could be in error as compared to more rigorous methods, such as finite element analysis methods. Specifically, torsional stiffness and stress distribution is very difficult to determine using simple hand calculations. In addition, the web shear distribution can be in error. The Independent Review Team will assess the existing calculations and perform or recommend supplemental analysis to provide a more exact determination of the need for the LRT operational restrictions during storms (Issue B and Issue J)</p>		
<b>Required Information for Independent Review Team’s Review</b>		
<p>Study that addresses the stresses in the bridge overhang, side wall and side wall/overhang joint that demonstrate that the calculations performed to date are accurate and do not represent an overstress condition.</p>		
<b>Data Sources and Documents Provided by Responsible Agency</b>		
<b>Resolution of Issue</b>		
<p>Calculations provided by Washington State DOT and Sound Transit have addressed this issue. The Independent Review Team’s independent assessment confirms the torsional capacity of the existing floating bridge (see Appendix B, Technical Memorandum TM-02, Torsional Analysis).</p>		

# Issue Resolution Report

**Title:**

Washington State Legislature, Joint Transportation Committee  
 Independent Review Team  
 Feasibility of Placing LRT on the Homer M. Hadley Floating Bridge

**Rev: Page:**

22 of 42

<b>Issue J Analysis "North Wind" Storm Effects on Homer M. Hadley Floating Bridge</b>		
<b>Independent Review Team Member Responsible for Resolution of Issue</b>	<b>Importance of Issue</b>	<b>Agency Responsible for Providing Resolution</b>
Tom Bringloe	Medium	Washington State DOT
<b>General Description and Background of Issue</b>		
<p>Earlier studies by KPFF concluded combined live load from two crush-loaded passing trains plus three lanes of HS25 highway loading plus a one-year recurrence storm would load the bridge to 97% of its capacity in torsion. The one-year wave loading was based on a south storm and ignored the wave sheltering provided by the LVM Bridge. This approach was taken because, at the time the original Homer M. Hadley wave load analysis was performed, the old LVM Bridge was a very old structure that was expected to be removed and replaced, leaving the Homer M. Hadley Bridge unprotected for some time period. And that situation in fact happened for two years.</p> <p>The question is whether a north storm would produce larger seas than the storms from the south because of the longer fetch and lack of protection. This question should be answered to resolve Issue B.</p>		
<b>Required Information for Independent Review Team's Review</b>		
All required information is in hand to address this issue.		
<b>Data Sources and Documents Provided by Responsible Agency</b>		
<ol style="list-style-type: none"> <li>1. The Glostén Associates, Inc., Wave Loading Analysis of Lake Washington Bridges Volume 1, June 1983.</li> <li>2. Unpublished work in progress on Lake Washington climatology re SR-520 bridge design, in the files of The Glostén Associates.</li> </ol>		
<b>Resolution of Issue</b>		
<p>The Independent Review Team has performed preliminary analysis for the 1-year north storm event and estimates that a storm from the north would produce significantly lower seas than the storm from the south used in previous assessment:</p> <ul style="list-style-type: none"> <li>• The sea condition characterized in the 1983 work as 1-year southerly storm was described as:                     <ul style="list-style-type: none"> <li>Significant wave height = 2.2 feet</li> <li>Peak period = 2.7 seconds</li> </ul> </li> <li>• Based on recent (unpublished) work done for the SR-520 site, the IRT computed a</li> </ul>		

# Issue Resolution Report

**Title:**

Washington State Legislature, Joint Transportation Committee  
Independent Review Team  
Feasibility of Placing LRT on the Homer M. Hadley Floating Bridge

**Rev:    Page:**

23 of 42

hindcast 1-year recurrence northerly sea condition of

Significant wave height = 1.2 feet

Peak period = 2.3 seconds

- Both height and period have a strong effect on bridge responses. We estimate that the torsional response to waves will be reduced to about 1600 kip-feet, compared to the 10,000 kip feet used in the earlier KPFF study.
- See “Wave Climatology” technical memo by Glostren Associates, Dated July 30, 2008 in Appendix B.

# Issue Resolution Report

**Title:**

Washington State Legislature, Joint Transportation Committee  
 Independent Review Team  
 Feasibility of Placing LRT on the Homer M. Hadley Floating Bridge

**Rev: Page:**

24 of 42

<b>Issue K Criteria Established for Independent Review Team to Evaluate Numerous Issues</b>		
<b>Independent Review Team Member Responsible for Resolution of Issue</b>	<b>Importance of Issue</b>	<b>Agency Responsible for Providing Resolution</b>
Tom Ballard	High	Washington State DOT and Sound Transit
<b>General Description and Background of Issue</b>		
<p>Design criteria for the East Link Project will be established by updating the North Link and Airport Link design criteria to address the unique requirements established in conceptual engineering. To evaluate issues relative to use of existing facilities, such as, the Homer M. Hadley bridge, approach spans, transition spans and west approach tunnel, the Independent Review Team needs confirmation of design criteria for several design details, such as:</p> <ol style="list-style-type: none"> <li>1. Stray current collector system (Issue F)</li> <li>2. Lightening arrestors for entire bridge (Issue E)</li> <li>3. Seismic return period and performance criteria (Issue C, Issue D,)</li> <li>4. Passenger safety and comfort criteria requirements (Issue M)</li> <li>5. Expansion joint and track bridge performance criteria (Issue A)</li> </ol> <p>This issue is considered critical in order for the Independent Review Team to make the assessment as to the feasibility of placing the LRT on the bridge.</p>		
<b>Required Information for Independent Review Team's Review</b>		
<p>Criteria for stray current collection, lightening protection, seismic return period and performance criteria for approach spans, passenger safety and comfort criteria and expansion joint and track bridge performance criteria.</p>		
<b>Data Sources and Documents Provided by Responsible Agency</b>		
<ol style="list-style-type: none"> <li>1. May 30th, 2008 letter from Sound Transit in response to the Independent Review Team's April 24, 2008 letter.</li> </ol>		
<b>Resolution of Issue</b>		
<p>Sound Transit and WSDOT provided or agreed to acceptable design criteria for all identified issues. The Independent Review Team recommends that Sound Transit issue policy level documentation whenever they choose to adopt design criteria that are less stringent than their own criteria when installing LRT on existing facilities owned by other agencies.</p>		

# Issue Resolution Report

**Title:**

Washington State Legislature, Joint Transportation Committee  
 Independent Review Team  
 Feasibility of Placing LRT on the Homer M. Hadley Floating Bridge

**Rev: Page:**

25 of 42

<b>Issue L Operation and Maintenance Coordination Agreement between Sound Transit and Washington State DOT</b>		
<b>Independent Review Team Member Responsible for Resolution of Issue</b>	<b>Importance of Issue</b>	<b>Agency Responsible for Providing Resolution</b>
Chuck Ruth	Medium	Washington State DOT and Sound Transit
<b>General Description and Background of Issue</b>		
<p>If appropriate staff and maintenance funds are not consistently dedicated to the operation and maintenance of the LRT and Homer M. Hadley Floating Bridge and approaches, it is unlikely that the adopted 100 year bridge life can be achieved.</p> <p>At the "executive" meeting the responsible Independent Review Team member attended on April 29, 2008, between Washington State DOT and Sound Transit, this issue was discussed. Sound Transit and Washington State DOT indicated that initial maintenance coordination discussions have been held. A multi-layer stray current collection system will be installed on the Homer M. Hadley Floating Bridge and approaches as part of the LRT construction. This system will require constant monitoring and dedicated maintenance staff and maintenance funds to achieve the desired bridge life (100 years total). This is only one element of many associated with maintenance of the bridge and the LRT facilities the bridge will have to support. With two agencies having maintenance functions on the same bridge at the same time, coordination, communication and commitment are essential.</p> <p>A plan for developing a coordinated operations and maintenance agreement to ensure the desirable life of the bridge should be developed, approved and implemented as part of the design/construction process.</p>		
<b>Required Information for Independent Review Team's Review</b>		
<p>Letter from Sound Transit and Washington State DOT establishing a plan to develop a coordinated operations and maintenance agreement for the bridge.</p>		
<b>Data Sources and Documents Provided by Responsible Agency</b>		
Empty cell for data sources		
<b>Resolution of Issue</b>		
<p>Washington State DOT and Sound Transit have made a commitment for development, review, and approval of a Sound Transit/Washington State DOT Operation and Maintenance Agreement for the Homer Hadley Bridge.</p>		

# Issue Resolution Report

**Title:**

Washington State Legislature, Joint Transportation Committee  
 Independent Review Team  
 Feasibility of Placing LRT on the Homer M. Hadley Floating Bridge

**Rev: Page:**

26 of 42

<b>Issue M Rider Comfort Performance for LRT Track Bridge at Expansion Joints</b>		
<b>Independent Review Team Member Responsible for Resolution of Issue</b>	<b>Importance of Issue</b>	<b>Agency Responsible for Providing Resolution</b>
Tom Ballard	High	Sound Transit
<b>General Description and Background of Issue</b>		
<p>The LRT vehicles will cross the transition spans and two track bridges at each end of the Homer M. Hadley Floating Bridge.</p> <p>The North Link and Airport Link design criteria, Section 12.7.6 Ride Quality, requires that: “The rms acceleration values shall not exceed the 4-hour, reduced comfort level (vertical) and 2.5 hr, reduced comfort level (horizontal) boundaries derived from Figure 2a (vertical) and Figure 3a (horizontal) of ISO 2631 over the range of 1 Hz to 80 Hz, for all load conditions AW0 to AW3.”</p> <p>The track bridge should be designed to meet these standards. There are two ways to demonstrate that this standard has been met. The design should be first based on an analytical model comprised of a vehicle dynamic based on Reference 1 and a track-structure model, based on the preliminary design for the track bridge. This model should be used to determine the shock and vibration levels that the vehicles are subjected to traveling at the proposed 30 and 40 mph operating speeds under load conditions AW0 and AW3. The final designed track bridge should then be prototyped before production.</p> <p>The maximum acceptable single amplitude horizontal acceleration is 0.05 g to 0.08 g. Also, refer to Issue 1 for further discussion of prototype testing.</p> <p>Since the track bridge is such a unique structure, it is important to determine if the track bridge is going to work from the standpoint of passenger safety and comfort.</p>		
<b>Required Information for Independent Review Team’s Review</b>		
<ul style="list-style-type: none"> <li>• Study reports on track bridge analysis for passenger ride quality and comfort.</li> <li>• Test plan for conducting tests of the track bridge.</li> </ul>		
<b>Data Sources and Documents Provided by Responsible Agency</b>		
<ol style="list-style-type: none"> <li>1. ER2013, Car Body Roll Control Method, Kinkisharyo International, L.L.C., Rev 0, March 31, 2005</li> <li>2. INCA Engineers, Inc., “Eastside HCT Corridor, I-90 floating Bridge (Homer Hadley), Expansion Joint Final Conceptual Report, January 2008.</li> <li>3. CH2M Hill, INCA Engineers and Parsons Transportation Group Working Draft</li> </ol>		



# Issue Resolution Report

**Title:**

Washington State Legislature, Joint Transportation Committee  
Independent Review Team  
Feasibility of Placing LRT on the Homer M. Hadley Floating Bridge

**Rev: Page:**

27 of 42

Technical Memorandum "Sound Transit East Link Project – Rider Comfort Performance for LRT Track Bridge at Expansion Joints", May 21, 2008

4. May 30th, 2008 letter from Sound Transit in response to the Independent Review Team's April 24, 2008 letter.

### Resolution of Issue

The Independent Review Team has performed independent analysis for this issue and has concluded that the LRT vehicle will most likely be able to traverse the track bridge during normal conditions without undue discomfort to the riders but with reduced speed. This conclusion should be revisited following final design and prototype testing of the track bridge elements, including 3-link beam, track fasteners, and centering mechanism. Sound Transit has anticipated the need to traverse the track bridges at reduced speeds, already taking this into account in its systems operations planning and evaluation studies to date.

See Vehicle Dynamics Analysis, SC Solutions Tech Memo TM-04, Dated August 6, 2008 in Appendix B

# Issue Resolution Report

**Title:**

Washington State Legislature, Joint Transportation Committee  
 Independent Review Team  
 Feasibility of Placing LRT on the Homer M. Hadley Floating Bridge

**Rev: Page:**

28 of 42

<b>Issue N Attachment of OCS Supports to Edge of Homer M. Hadley Floating Bridge Deck Cantilevers</b>		
<b>Independent Review Team Member Responsible for Resolution of Issue</b>	<b>Importance of Issue</b>	<b>Agency Responsible for Providing Resolution</b>
Chuck Ruth	High	Washington State DOT and Sound Transit
<b>General Description and Background of Issue</b>		
<p>The proposed Overhead Contact System (OCS) pole support attachments rely on retaining a 4 to 8 foot piece of the existing traffic barrier at the edge of the cantilever and new attachments/connections into the existing concrete at the edge of the cantilever at every OCS pole location. The ends of the cantilevers are in good condition in their current configuration. Located at the ends of the cantilever are the transverse deck post tensioning tendon anchorages (and surrounding bursting stress reinforcing) that support the entire cantilever. There is mild reinforcing steel as well for load distribution. Damage to any of these elements is not acceptable structurally. Therefore, the OCS support pole attachment and support base load distribution needs to be carefully studied, analyzed, and detailed to prevent any potential damage to the end of the cantilever. The goal should be to design an OCS support pole attachment that minimizes barrier removal and does not rely on any direct connection into the end of the cantilever.</p> <p>Constructing the OCS pole attachments could damage the deck in a manner that may not be repairable. Therefore an acceptable OCS pole attachment concept should be developed prior to the start of preliminary design. The OCS poles and attachments should not impact the structural integrity of the bridge and should not cause cracking on the deck.</p>		
<b>Required Information for Independent Review Team's Review</b>		
Calculations supporting the design for the attachment of the OCS poles to the deck overhang.		
<b>Data Sources and Documents Provided by Responsible Agency</b>		
<ol style="list-style-type: none"> <li>1. Parsons, "East Link Project, Overhead Catenary System Concept Study, Final Draft Report, December 2007</li> <li>2. CH2M Hill and INCA Engineers Working Draft Technical Memorandum "Sound Transit East Link Project – OCS Pole/Deck Attachment Analysis", May 16, 2008</li> <li>3. INCA Engineers, Inc., Sound Transit East Link Phase 2 Project – IRT ISSUE N – Attachment of OCS Supports to Edge of Homer M. Hadley Floating Bridge Deck Cantilevers, June 13, 2008.</li> </ol>		

# Issue Resolution Report

**Title:**

Washington State Legislature, Joint Transportation Committee  
Independent Review Team  
Feasibility of Placing LRT on the Homer M. Hadley Floating Bridge

**Rev:    Page:**

29 of 42

## Resolution of Issue

Sound Transit has provided the Independent Review Team with acceptable conceptual OCS and fall protection rail post attachment details that minimize penetrations into the existing pontoon concrete deck South cantilever. Further analysis will be performed by Sound Transit to prove concept during preliminary design. The IRT has also analyzed the OCS attachment concept proposed by Sound Transit. The IRT analysis indicates that the concept results in tolerable stress levels in the existing bridge (see Appendix B, Technical Memorandum TM-01 OCS Pole Load Analysis).

# Issue Resolution Report

**Title:**

Washington State Legislature, Joint Transportation Committee  
 Independent Review Team  
 Feasibility of Placing LRT on the Homer M. Hadley Floating Bridge

**Rev: Page:**

30 of 42

<b>Issue O Methods to be Utilized for Locating Rebar and Post Tensioning in Bridge Deck</b>		
<b>Independent Review Team Member Responsible for Resolution of Issue</b>	<b>Importance of Issue</b>	<b>Agency Responsible for Providing Resolution</b>
Ali Akbar Sohanghpurwala	High	Washington State DOT and Sound Transit
<b>General Description and Background of Issue</b>		
<p>Plinths will need to be installed for the attachment of the rail tracks and they will be fastened onto the deck slab. However, the higher density of conventional reinforcement and the presence of transverse post tensioning in the floating bridge pose a construction challenge.</p> <p>Sound Transit has proposed to install plinths at 2' 6" on center, longitudinally. Two plinths will be required per track, i.e. a total of 4 plinths will be required at each longitudinal marker. They initially proposed to fasten each plinth to the deck with two epoxy coated anchors. Each anchor would sit in a hole drilled partially into the bridge deck and each would be approximately 5/8" in diameter and 4 1/8" deep. Therefore, at each longitudinal marker, a total of eight holes would have to be drilled. Washington State DOT indicates that there should be no damage to the post tensioning and would like to minimize damage to the conventional reinforcements as any damage would impact the overall integrity of the deck slab and reduce its service life. Also, the number of penetrations in the deck slab could reduce its overall structural integrity. Therefore, the plinth installation should be conducted with the highest level of efficiency in locating the reinforcement and making only penetrations that are absolutely necessary. To do so, a high accuracy mechanism to locate reinforcement will be required.</p> <p>Although several techniques such as ground penetrating radar survey and X-ray of the concrete slab can be used for this purpose, Washington State DOT has had limited success with them on this structure. Sound Transit should evaluate the applicability of these technologies to this particular situation and perform some preliminary field studies to demonstrate feasibility of such technology on this structure and determine the absolute minimum number of penetrations (if any) required for acceptable performance of the plinths.</p>		
<b>Required Information for Independent Review Team's Review</b>		
<ul style="list-style-type: none"> <li>• Sound Transit should demonstrate a mechanism or protocol for locating reinforcing steel on the deck surface without any more excavations than necessary to install the plinths. The number of plinths and tolerance on the spacing of the plinths needs to be considered.</li> <li>• Sound Transit needs to demonstrate that the method(s) selected can locate the reinforcing and post tensioning within a high level of accuracy necessary to assure that no transverse post-tensioning tendons are damaged and that damage to existing mild reinforcing steel is minimized.</li> </ul>		

# Issue Resolution Report

**Title:**

Washington State Legislature, Joint Transportation Committee  
Independent Review Team  
Feasibility of Placing LRT on the Homer M. Hadley Floating Bridge

**Rev:    Page:**

31 of 42

## Data Sources and Documents Provided by Responsible Agency

1. Pontoon Bars, which contains slides and drawings identifying reinforcement in the deck slab.
2. CH2M Hill and INCA Engineers Working Draft Technical Memorandum "Sound Transit East Link Project – Plinth Block Analysis", May 20, 2008
3. Mayes Testing Engineers, Sound Transit East Link Non-Destructive Testing Demonstration/Evaluation – Mayes Testing Engineers Project Number S08040, June 10, 2008.

## Resolution of Issue

Sound Transit has conducted a field evaluation of several technologies to ascertain their effectiveness in locating reinforcing steel in the deck slab and the report has been submitted. The report concludes that these technologies can be an effective tool to locate reinforcement including post-tensioned bars in the deck slab for placement of the plinths.

Sound Transit has indicated that they are researching plinth attachment methods that minimize and/or eliminate penetrations into the deck. The Independent Review Team encourages the development of these alternate plinth attachment methods. Such alternative attachment methods may be more critical for the segmental concrete approach spans due to longitudinal post tensioning congestion at the piers.

# Issue Resolution Report

**Title:**

Washington State Legislature, Joint Transportation Committee  
 Independent Review Team  
 Feasibility of Placing LRT on the Homer M. Hadley Floating Bridge

**Rev: Page:**

32 of 42

<b>Issue P Determining Strength and Electrical Resistance of Existing Concrete</b>		
<b>Independent Review Team Member Responsible for Resolution of Issue</b>	<b>Importance of Issue</b>	<b>Agency Responsible for Providing Resolution</b>
Ali Akbar Sohanghpurwala	Medium	Washington State DOT
<b>General Description and Background of Issue</b>		
<p>To ascertain the impact of plinth block installation on the deck slab, information on the strength of in place concrete will be required. The strength of concrete is also required to ascertain the time to cracking due to stray current discharge from reinforcement in the pontoon. In addition, the resistivity of concrete is required for determining the impact of stray current on the structure. The information on the resistivity of concrete is helpful in understanding the resistance offered by the pontoon deck slab to the flow of stray current down the pontoon walls to the below the water level where it is likely to cause corrosion.</p>		
<b>Required Information for Independent Review Team’s Review</b>		
<p>Washington State DOT to provide any information available which would be used to make a reasonable guess at the in place concrete strength. The resistivity of the deck concrete will have to be obtained by literature review or by in-place testing of the existing concrete.</p>		
<b>Data Sources and Documents Provided by Responsible Agency</b>		
<b>Resolution of Issue</b>		
<p>Concrete sampling and testing has been completed. The test results will be utilized by Sound Transit for their design. See Appendix B, “I-90 Independent Review Team Resistivity, Unit Weight, &amp; Absorption Test Results” dated August 14, 2008, by Concorr, Inc.</p>		

# Issue Resolution Report

**Title:**

Washington State Legislature, Joint Transportation Committee  
 Independent Review Team  
 Feasibility of Placing LRT on the Homer M. Hadley Floating Bridge

**Rev: Page:**

33 of 42

<b>Issue Q Modification of Current Bridge Inspection Procedures For LRT Installation</b>		
<b>Independent Review Team Member Responsible for Resolution of Issue</b>	<b>Importance of Issue</b>	<b>Agency Responsible for Providing Resolution</b>
Steve Nikolakakos	Low	Washington State DOT and Sound Transit
<b>General Description and Background of Issue</b>		
<p>The current Bridge Inspection Procedures would need to be modified, if a Light Rail Transit (LRT) system is approved for the bridge, to allow for more thorough and more frequent inspections in order to monitor for stray current damage, if any, to the bridge structures.</p> <p>The current inspection program of the Washington State DOT for the bridge structures include:</p> <ul style="list-style-type: none"> <li>• Interim Inspection of the bridge roadway decks (approximate inspection frequency – 24 months).</li> <li>• Interim inspection of the Assembly Joint (approximate inspection frequency – 6 months).</li> <li>• Routine, fracture critical, and special inspections with a under the bridge inspection truck (approximate inspection frequency – 24 months).</li> <li>• Walk-thru inspection of the Post-Tensioned Box Girders Spans 1-6 and 10-16 approximate inspection frequency – 72 months).</li> <li>• Watertight inspection of the pontoons (inspection frequency – 12 months).</li> <li>• Underwater inspection of the pontoons (inspection frequency – 72 months).</li> <li>• Inspection of the anchor cables (approximate inspection frequency – 24 months).</li> </ul> <p>In addition, Washington State DOT/Sound Transit would need to address the issue of updating the existing cathodic protection system to provide corrosion protection to the pontoon walls and the anchor cable system (See Issue H). A modified cathodic protection system would also minimize the stray current corrosion on the reinforcement steel off the pontoon walls. An annual inspection and test program should be adopted for the updated cathodic protection system(s).</p> <p>Early detection of stray current problems is absolutely necessary, and therefore a stray current monitoring system is required (See Issues F &amp; U). It follows that inspection and maintenance of the stray current monitoring system is also a critical bridge operation function. Visual detection of corrosion in submerged pontoon walls would be an indication that the stray current collection and monitoring system had failed.</p>		

# Issue Resolution Report

**Title:**

Washington State Legislature, Joint Transportation Committee  
Independent Review Team  
Feasibility of Placing LRT on the Homer M. Hadley Floating Bridge

**Rev: Page:**

34 of 42

## Required Information for Independent Review Team's Review

Information on proposed modifications to inspection procedures should be provided to Independent Review Team by Washington State DOT and Sound Transit for review and evaluation. Information provided should include:

- Type of modifications proposed for each inspection, and change, if any, to frequency of inspection.
- Modifications, if any, proposed for the cathodic protection systems, including inspection requirements.

The above information is required to determine if modified inspection procedures would be adequate to detect stray current corrosion in the early stages, mitigate the stray current condition and prevent/minimize corrosion.

## Data Sources and Documents Provided by Responsible Agency

1. Bridge Inspection Report dated 1/22/2008; Homer M. Hadley Bridge - (Washington State DOT)
2. Underwater Inspection Report for the Homer Hadley Floating Bridge dated September, 2006 – (Washington State DOT)

## Resolution of Issue

The Independent Review Team recommends that the current inspection procedures and frequency be modified to timely detect and mitigate/repair any problems that may have resulted from the operation of the LRT. To properly monitor, maintain and operate the Homer Hadley Bridge with LRT will require adequate funding and in-house expertise in the following engineering disciplines.

- Structural engineering with bridge preservation background.
- Electrical engineering with cathodic protection and stray current background.
- Material science with corrosion background.

These skill sets are more suitable for incorporation into Washington State DOT staff as they will be useful in preservation of other structures. This recommendation can be met through hiring additional Washington State DOT staff with the required expertise or providing training or certification to existing staff.



# Issue Resolution Report

**Title:**

Washington State Legislature, Joint Transportation Committee  
 Independent Review Team  
 Feasibility of Placing LRT on the Homer M. Hadley Floating Bridge

**Rev:    Page:**

35 of 42

<b>Issue R    Storm water Drainage System Modifications under New LRT Track Bridge at Expansion Joints</b>		
<b>Independent Review Team Member Responsible for Resolution of Issue</b>	<b>Importance of Issue</b>	<b>Agency Responsible for Providing Resolution</b>
Chuck Ruth	Low	Washington State DOT and Sound Transit
<b>General Description and Background of Issue</b>		
<p>Developing workable details to direct storm water into the existing collection system should not present a major problem. Sound Transit is proposing that the Transition Span expansion joints be removed in the area of the LRT. This will require that the deck surface storm water be collected and directed into the existing collection system. There are a number of ways this could be done and should not present a major problem for design or construction.</p>		
<b>Required Information for Independent Review Team’s Review</b>		
<p>Preliminary design details and calculations for storm water drainage system modifications under track bridge at expansion joints.</p>		
<b>Data Sources and Documents Provided by Responsible Agency</b>		
<p>1. Parsons, Sound Transit East Link Project – Drainage Details at Expansion Joints, June 12, 2008</p>		
<b>Resolution of Issue</b>		
<p>Sound Transit has provided the Independent Review Team with acceptable conceptual details of the anticipated expansion joint (under the track bridges and adjacent maintenance access lane) and the conceptual method for collecting storm water and transporting it into the existing storm water drainage system.</p>		

# Issue Resolution Report

**Title:**

Washington State Legislature, Joint Transportation Committee  
 Independent Review Team  
 Feasibility of Placing LRT on the Homer M. Hadley Floating Bridge

**Rev: Page:**

36 of 42

<b>Issue S Median Barrier Relocation Design, Attachment, Maintenance and Drainage</b>		
<b>Independent Review Team Member Responsible for Resolution of Issue</b>	<b>Importance of Issue</b>	<b>Agency Responsible for Providing Resolution</b>
Chuck Ruth	High	Washington State DOT and Sound Transit
<b>General Description and Background of Issue</b>		
<p>Relocation of the median barrier proposed by the I-90 Two-Way HOV/Transit Project (R-8A) is not desirable from a structural standpoint as new barrier attachments to the existing deck represent potential damage to existing post tensioning and reinforcing steel. Moving the median barrier may damage the deck and therefore a preliminary approach should be developed and approved prior to the start of final design.</p> <p>The goal of any median barrier relocation concept should be to maintain the existing pontoon access, storm water drainage, and assure that the structural integrity of the bridge and bridge deck.</p>		
<b>Required Information for Independent Review Team’s Review</b>		
<p>Proposed details and calculations associated with the new barrier placement, showing attachments, avoidance of post tensioning and rebar, and maintenance access.</p>		
<b>Data Sources and Documents Provided by Responsible Agency</b>		
<p>1. INCA Engineers, Inc., Sound Transit East Link Phase 2 Project – IRT ISSUE S – Median Barrier Relocation, Design, Attachment, Maintenance and Drainage, June 13, 2008.</p>		
<b>Resolution of Issue</b>		
<p>Sound Transit provided preliminary design concepts that suggest three alternative approaches. Sound Transit and Washington State DOT will study all three alternatives to determine optimum alternative. The Independent Review Team recommends that every effort be made to avoid relocation of the existing median.</p>		

# Issue Resolution Report

**Title:**

Washington State Legislature, Joint Transportation Committee  
 Independent Review Team  
 Feasibility of Placing LRT on the Homer M. Hadley Floating Bridge

**Rev: Page:**

37 of 42

<b>Issue T Washington State DOT's and Sound Transit's Goal for Life Expectancy of Bridge</b>		
<b>Independent Review Team Member Responsible for Resolution of Issue</b>	<b>Importance of Issue</b>	<b>Agency Responsible for Providing Resolution</b>
Tom Ballard	High	Washington State DOT and Sound Transit
<b>General Description and Background of Issue</b>		
<p>In order to determine the extent of corrosion protection required, the extent of expected corrosion damage due to stray current and other aspects of the design, such as, level of risk associated with a storm or earthquake return period, the life expectancy of the bridge needs to be stated.</p>		
<b>Required Information for Independent Review Team's Review</b>		
<p>Bridge design life proposed by WSDOT and Sound Transit.</p>		
<b>Data Sources and Documents Provided by Responsible Agency</b>		
<ol style="list-style-type: none"> <li>1. Letter from Washington State DOT and Sound Transit regarding the agreement made on April 29, 2008.</li> <li>2. Washington State DOT and Sound Transit Letter to IRT Establishing Bridge Life Expectancy, May 13, 2008.</li> </ol>		
<b>Resolution of Issue</b>		
<p>WSDOT and Sound Transit have selected a total bridge life goal of 100 years. This issue is resolved; however, the Joint Transportation Committee should be aware that by defining the total life of the bridge as 100 years, the remaining life, following the installation of LRT is 70 years. The useful life of structures in the entire LRT system will be variable. The Downtown Seattle Transit Tunnel which all LRT lines in the Sound Transit system operate through is approaching 20 years old and Airport Link will be 11 years old by the time East Link opens. The East Link will ultimately include an Operations and Maintenance facility on the Eastside and be capable of intra-Eastside operations with a bus 'bridge' to Seattle when it comes time to replace the Homer M. Hadley floating bridge.</p>		

# Issue Resolution Report

**Title:**

Washington State Legislature, Joint Transportation Committee  
 Independent Review Team  
 Feasibility of Placing LRT on the Homer M. Hadley Floating Bridge

**Rev: Page:**

38 of 42

<b>Issue U Method for Identifying Stray Current Failure and Response/Repair Plan</b>		
<b>Independent Review Team Member Responsible for Resolution of Issue</b>	<b>Importance of Issue</b>	<b>Agency Responsible for Providing Resolution</b>
Steve Nikolakakos	Medium	Washington State DOT and Sound Transit
<b>General Description and Background of Issue</b>		
<p>Stray current control measures for a new light rail system mostly consist of insulated rail fasteners, low resistance negative return circuit, and high resistivity concrete ties/plinths. Under normal operating conditions, where the track-to-earth resistance is within design limits, the stray current effects on structures and utilities are in most cases minimal. Under abnormal operating conditions however, where the track-to-earth resistance is lower than the design limits due to insulation damage/failure of the rail fasteners, a significant increase in stray current can result that may have an adverse affect on the structures and utilities. Methods to monitor increased levels of stray current should be implemented in a system in order to timely identify and repair the failed system component and minimize the stray current effects on the structures/utilities. Additional measures, that can be used, to minimize these effects include design and installation of a stray current collection/mitigation system (discussed in Issue F).</p> <p>Sound Transit proposes continuous monitoring for stray current. Sound Transit should provide the Independent Review Team a plan for developing procedures to be used in identifying system failures, failed components, and repair/replacement of failed components.</p>		
<b>Required Information for Independent Review Team’s Review</b>		
<p>Information on the proposed stray current monitoring system should be provided to Independent Review Team for review and evaluation. Information provided should include:</p> <ul style="list-style-type: none"> <li>• The type of monitoring system, such as stray current measurements, track-to-earth resistance, etc.</li> <li>• Frequency of monitoring.</li> <li>• Method for analysis of the monitoring system results.</li> <li>• Method for identifying failed system components such as rail fastener insulation.</li> <li>• Proposed maintenance and repair/replacement schedule.</li> </ul> <p>The above information will allow the Independent Review Team to ensure that the monitoring system put in place will provide reliable data that could be analyzed, and used to detect system failures that can be repaired in a timely manner and thus prevent/minimize the damaging effect of the stray current on structures, reinforcing steel and/or utilities.</p>		

# Issue Resolution Report

**Title:**

Washington State Legislature, Joint Transportation Committee  
Independent Review Team  
Feasibility of Placing LRT on the Homer M. Hadley Floating Bridge

**Rev:    Page:**

39 of 42

## Data Sources and Documents Provided by Responsible Agency

1. May 30th, 2008 letter from Sound Transit in response to the Independent Review Team's April 24, 2008 letter.
2. Sound Transit East Link Project – Issue Resolution Report – Support Data; June 13, 2008.

## Resolution of Issue

Sound Transit has agreed to the following preliminary details of the monitoring system.

The stray current remote monitoring system, as a minimum, should include:

- Track-to-earth resistance measurements (two times a year).
- Continuous stray current measurements at each ground electrode.
- Continuous voltage measurements of stray current collector mats

The design of the monitoring system, as a minimum, should include:

- Current shunts for measuring the stray current.
- Diodes at ground electrodes.
- Continuity monitoring of the collector mat
- Initiation of alarms if the stray current or the track-to-earth resistance exceeds a pre-set value.
- A monitoring system that is capable to collect and store data at programmed intervals.

The repair/maintenance procedure should include a method of inspection/evaluation if an alarm is initiated from the monitoring system.

Washington State DOT should have approval authority over the selected system and Washington State DOT should have access to expertise to evaluate the selected system.

# Issue Resolution Report

**Title:**

Washington State Legislature, Joint Transportation Committee  
 Independent Review Team  
 Feasibility of Placing LRT on the Homer M. Hadley Floating Bridge

**Rev: Page:**

40 of 42

<b>Issue V Effect of LRT Installation on Construction Operations Associated With Anchor Cable Replacement</b>		
<b>Independent Review Team Member Responsible for Resolution of Issue</b>	<b>Importance of Issue</b>	<b>Agency Responsible for Providing Resolution</b>
Tom Bringloe	Low	Washington State DOT and Sound Transit
<b>General Description and Background of Issue</b>		
<p>South anchors cables on the Homer M. Hadley bridge (as well as North cables on the LVM Bridge) extend down through the channel between the two bridges. Large construction or crane barges do not fit between the bridges, so it is necessary to reach over the roadway with a large barge mounted crane, or have a truck crane parked on the shoulder to handle the weights involved. Crane operations will not be permitted close to or reaching over the live overhead catenary wires. Anchor cable maintenance/replacement may have to be limited to night shifts when the wires can be de-energized. It is thought that this is a Washington State DOT maintenance issue, not a feasibility issue.</p>		
<b>Required Information for Independent Review Team’s Review</b>		
No additional information required.		
<b>Data Sources and Documents Provided by Responsible Agency</b>		
None		
<b>Resolution of Issue</b>		
<p>The Independent Review Team believes that anchor cable replacement can be performed without impact on the LRT operations, safety or cost of replacement.</p> <p>Following discussions with previous anchor cable installation contractors, the IRT has determined that anchor cable replacement can be achieved without cranes reaching over the bridge. Small portable barges can be floated into the channel and latched together to form a work platform. This work platform can be fitted with winches and low profile equipment that can perform all of the required functions. A larger derrick barge moored on the outside can support the majority of the cable weight.</p>		

# Issue Resolution Report

**Title:**

Washington State Legislature, Joint Transportation Committee  
 Independent Review Team  
 Feasibility of Placing LRT on the Homer M. Hadley Floating Bridge

**Rev: Page:**

41 of 42

<b>Issue W Additional Needs and Changes Required for LRT Installation to meet "Blue Ribbon Panel" Recommendations</b>		
<b>Independent Review Team Member Responsible for Resolution of Issue</b>	<b>Importance of Issue</b>	<b>Agency Responsible for Providing Resolution</b>
Tom Bringloe	Low	Washington State DOT and Sound Transit
<b>General Description and Background of Issue</b>		
<p>The report of the Governor’s Blue Ribbon Panel, convened following the sinking of the LVM Bridge, is the established standard for Washington State DOT construction and maintenance work on floating structures. It will not likely raise any project feasibility issues. However it contains provisions that the designers should incorporate into any special provisions for work on the bridge and will likely affect Washington State DOT and Sound Transit maintenance operation procedures and priorities.</p>		
<b>Required Information for Independent Review Team’s Review</b>		
No additional information required.		
<b>Data Sources and Documents Provided by Responsible Agency</b>		
<ol style="list-style-type: none"> <li>1. Report of the Governor’s Blue Ribbon Panel, Investigation into the Sinking of the I-90 Lacey V. Murrow Bridge, May 2, 1991.</li> </ol>		
<b>Resolution of Issue</b>		
<p>The Blue Ribbon Panel recommendations contain provisions that the designers should incorporate into any special provisions for work on the bridge and will likely affect Washington State DOT and Sound Transit maintenance operation procedures and priorities. The specific recommendations, and the appropriate times to implement them are:</p> <p><b>Recommendations that have been implemented by Washington State DOT</b></p> <ul style="list-style-type: none"> <li>• <i>Electronic surveillance:</i> implement an electronic system to monitor water level in all cells.</li> <li>• <i>Automated bridge barricades:</i> Study the most effective mechanical means to close the bridge when needed.</li> </ul> <p><b>Recommendations for contract provisions and other detailed design phase activities. Language has been developed by Washington State DOT.</b></p> <ul style="list-style-type: none"> <li>• <i>Reconstruction or renovation:</i> Washington State DOT to prepare a set of contractual provisions that establish minimum standards for surveillance, inspection, reporting, and</li> </ul>		

# Issue Resolution Report

## Title:

Washington State Legislature, Joint Transportation Committee  
Independent Review Team  
Feasibility of Placing LRT on the Homer M. Hadley Floating Bridge

Rev: Page:

42 of 42

immediate rectification of discrepancies during construction.

- *Interagency cooperation:* Fully implement the agreement between the Washington State DOT and the Department of Ecology.
- *Environmental requirements:* Require contractor to demonstrate knowledge of environmental regulations when bidding.
- *Construction practices:* Incorporate procedures for assuring watertightness, and for surveillance and response activities.
- *Prequalification of contractors:* Contractor prequalification includes marine expertise.

### Recommendations that will apply during construction

- *Contract enforcement:* Assure that bridge safety requirements are fully implemented.
- *Outside counsel:* Since rapid decisions are sometimes critically necessary, consider the assignment of outside contract counsel on major projects.

### Recommendations that will apply to ongoing operations. Note that Washington State DOT and Sound Transit have committed to a joint operating agreement.

- *Independent random inspections:* To be conducted, emphasizing the watertightness of the bridge and the reliability of systems.
- *Staff continuity:* Review the training procedures for personnel who make decisions in inclement weather, and assure implementation and back-up in all key positions.

## Conclusion

The Independent Review Team concludes that all issues identified as impacting LRT installation can be addressed or mitigated providing that the IRT resolutions and recommendations are incorporated. However, several issues could affect project cost estimates and schedules and therefore should be resolved at the earliest stages of the project design. One issue, A, deals with a required design element (LRT Expansion Joint Track Bridge) that has no history of use on floating bridges, and therefore requires careful study and testing in the early stages of the project.



# I-90 HOMER HADLEY FLOATING BRIDGE

Independent Review Team - Light Rail Train Impacts



## ***APPENDIX B: TECHNICAL MEMORANDUMS***

***B1: OVERHEAD CONTACT SYSTEM POLE LOAD ANALYSIS***

***B2: TORSIONAL ANALYSIS***

***B3: EXPANSION JOINT ANALYSIS***

***B4: VEHICLE DYNAMICS ANALYSIS***

***B5: SEISMIC VULNERABILITY ASSESSMENT OF THE WEST APPROACH AND TRANSITION SPANS***

***B6: WAVE CLIMATOLOGY***

***B7: IMPACT OF STRAY CURRENT ON REMAINING SERVICE LIFE***

***B8: RESISTIVITY, UNIT WEIGHT AND ABSORPTION TEST RESULTS***

**I-90 Homer Hadley Floating Bridge – LRT Impacts  
TECHNICAL MEMORANDUM COVER SHEET**

**Technical Memorandum TM-01  
OCS Pole Load Analysis**

**Prepared by: SC Solutions  
Date: August 6, 2008**

**Disclaimer:**

The analysis in this technical document is preliminary and is strictly to be used as advice in determining the feasibility of placing the LRT on the Homer Hadley Floating Bridge and approach spans. It is not intended for any other purpose or as the basis for any final design or construction issue associated with this project.

<b>I-90 Homer Hadley Floating Bridge – LRT Impacts</b>		<b>SC Solutions</b>
<b>Subject/Description:</b> <b>OCS Pole Load Analysis</b>	Originator: H.J. Lee	Date: 8/6/08
	Checked: Hassan Sedarat	Date: 8/6/08
Disclaimer: The analysis in this technical document is preliminary and is strictly to be used as advice in determining the feasibility of placing the LRT on the Homer Hadley Floating Bridge and approach spans. It is not intended for any other purpose or as the basis for any final design or construction issue associated with this project.	Calculation No.:TM-01	
	Rev No.: 0	Sheet 2 of 40

## Table of Contents

<b>1. Introduction</b> .....	3
1.1 Problem Statement .....	3
1.2 Objective .....	3
<b>2. Basis for Analysis</b> .....	4
2.1 OCS Model Development.....	4
2.2 OCS Model Loading Condition.....	4
2.3 OCS Model Geometry .....	5
2.4 OCS Model Constraint and Restraint .....	5
2.5 OCS Model Post-Tensioning Bars.....	5
2.6 OCS Model Material Properties.....	6
2.7 Cantilever Model Development.....	6
2.8 Cantilever Model Load and Boundary Conditions .....	6
2.9 Load Cases considered for the Cantilever Model .....	7
<b>3. Discussion</b> .....	18
3.1 OCS Model Analysis Results.....	18
3.2 Cantilever Model Analysis Results – Stress Values .....	19
3.2.1 Case 1 with OCS Pole Loads .....	19
3.2.2 Case 2 without OCS Pole Loads.....	19
3.3 Cantilever Model Analysis Results – Contour Plots.....	20
3.3.1 Case 1 with OCS Pole Loads .....	20
3.3.2 Case 2 without OCS Pole Loads.....	21
<b>4. Conclusion</b> .....	38
4.1 Conclusion based on OCS Model Analysis Results .....	38
4.2 Conclusion based on Cantilever Model Analysis Results .....	39
<b>5. References</b> .....	39

<b>I-90 Homer Hadley Floating Bridge – LRT Impacts</b>		<b>SC Solutions</b>
<b>Subject/Description:</b> <b>OCS Pole Load Analysis</b>	Originator: H.J. Lee	Date: 8/6/08
	Checked: Hassan Sedarat	Date: 8/6/08
Disclaimer: The analysis in this technical document is preliminary and is strictly to be used as advice in determining the feasibility of placing the LRT on the Homer Hadley Floating Bridge and approach spans. It is not intended for any other purpose or as the basis for any final design or construction issue associated with this project.	Calculation No.:TM-01	
	Rev No.: 0	Sheet 3 of 40

## 1. Introduction

### 1.1 Problem Statement

As part of the sound transit east link project, poles on the deck pontoon bridge for the Overhead Contact System (OCS) will be installed at 200 ft intervals. According to the report by Parsons and INCA [1], it was pointed out that the OCS pole bases attract large moments at the existing deck. The existing deck slab was not designed to carry this size of load and the increased load should be distributed by sufficient anchor blocks. There was a concern about the corrosive environment at the roadway deck surface and thus it needs to be confirmed that transverse post-tensioning forces at the roadway deck are sufficient to prevent tensile stresses at the roadway surface under OCS pole loads. It was also necessary to clarify the effects of light rail vehicle loads. The combined effects of OCS pole loads and light rail vehicle loads on the roadway deck and the pontoon wall were investigated in this study.

### 1.2 Objective

Two different finite element analysis models were built to investigate stresses at the roadway deck and the pontoon wall. One is the OCS model without light rail vehicle loads and the other is the cantilever model with light rail vehicle loads. A two-track cantilever configuration with a single pole at the end of the cantilever slab was analyzed in this study. The combined effects of self weight, post-tensioning forces, OCS pole loads, and light rail vehicle loads were investigated. The specific objectives of this study are as follows:

- Investigate maximum principal tensile stresses at the roadway deck under self weight + post-tension forces + OCS pole loads
- Investigate normal compressive stresses at the deck critical sections under self weight + post-tension forces + OCS pole loads

<b>I-90 Homer Hadley Floating Bridge – LRT Impacts</b>		<b>SC Solutions</b>
Subject/Description: <b>OCS Pole Load Analysis</b>	Originator: H.J. Lee	Date: 8/6/08
	Checked: Hassan Sedarat	Date: 8/6/08
Disclaimer: The analysis in this technical document is preliminary and is strictly to be used as advice in determining the feasibility of placing the LRT on the Homer Hadley Floating Bridge and approach spans. It is not intended for any other purpose or as the basis for any final design or construction issue associated with this project.	Calculation No.:TM-01	
	Rev No.: 0	Sheet 4 of 40

- Investigate maximum principal tensile stresses at the roadway deck and the pontoon wall under self weight + post-tension forces + OCS pole loads + light rail vehicle loads
- Investigate normal compressive stresses at the roadway deck and the pontoon wall under self weight + post-tension forces + OCS pole loads + light rail vehicle loads

## 2. Basis for Analysis

### 2.1 OCS Model Development

A two-track cantilever configuration with a single pole at the end of the cantilever slab (**Figure 2-1**) was analyzed in this study. According to the report by Parsons and INCA [1], the ultimate moment capacity of the existing deck is about 12 kips-ft/ft, while the factored moment demand is 94 kips-ft for the two-track cantilever structure. Therefore, these loads need to be distributed along at least 8 ft length. A 10-ft OCS pole anchor block proposed by INCA for the two-track cantilever structure (**Figure 2-2** and **Figure 2-3**) was analyzed using a finite element analysis program ADINA [2]. Due to the geometric irregularities of the OCS anchor block, three-dimensional finite element analyses using ADINA 20-node solid elements were performed.

### 2.2 OCS Model Loading Condition

According to the report by Parsons and INCA [1], the estimated unfactored loads at the base of the OCS pole spaced at 200 ft are as follows:

$V$  (Axial) = 3.8 kips,  $H$  (Shear transverse to LRT tracks) = 2.3 kips,

$M$  (Moment on pole base transverse to LRT tracks) = 72 kips-ft.

On top of these OCS pole loads, self weight and transverse post-tensioning forces were also included in the OCS model analysis. The OCS moment and the moment due to post-tension forces are in the same direction. The moment direction due to self weight is opposite to that of moments due to the OCS and post-tensioning forces. These unfactored loads were used for the three-dimensional finite element analysis. Since the analysis is

I-90 Homer Hadley Floating Bridge – LRT Impacts		SC Solutions
Subject/Description: <b>OCS Pole Load Analysis</b>	Originator: H.J. Lee	Date: 8/6/08
	Checked: Hassan Sedarat	Date: 8/6/08
Disclaimer: The analysis in this technical document is preliminary and is strictly to be used as advice in determining the feasibility of placing the LRT on the Homer Hadley Floating Bridge and approach spans. It is not intended for any other purpose or as the basis for any final design or construction issue associated with this project.	Calculation No.:TM-01	
	Rev No.: 0	Sheet 5 of 40

linear elastic, any load factor can be directly multiplied to the result obtained from this study.

### 2.3 OCS Model Geometry

The cantilever slab of Pontoon J combined with the OCS pole anchor block was selected for this analysis (**Figure 2-4**). The model was cut at a distance of 3 times OCS pole anchor block width in the transverse direction. Since the finite element model has a limited substructure model boundary, it was necessary to remove boundary effects for reasonable predictions of three-dimensional stress state. Based on a parametric study on substructure model boundary, the model with a 30-ft longitudinal length and restraints at the model boundary as shown in **Figure 2-5** was selected for this study.

### 2.4 OCS Model Constraint and Restraint

The model has restraints against translation in the longitudinal direction at the longitudinal ends of the substructure model. The cut section of the model in the middle of the cantilever part was restrained against translation in all directions.

The roadway deck and the OCS pole anchor block were modeled as ADINA 20-node solid elements. It was assumed that the OCS anchor block is fully connected to the deck slab. Rigid links were used in the area of the base plate of the OCS pole to apply OCS pole loads (**Figure 2-6**). The OCS pole loads were applied to a master node located at the centroid of the rigid links.

### 2.5 OCS Model Post-Tensioning Bars

Transverse post-tension bars were modeled as truss elements and the profile of post-tension bars matched to the mesh line as shown in **Figure 2-7**. It was assumed that transverse post-tension bars are spaced at 21 inch. Post-tension forces were applied by using an initial strain option in ADINA. Based on the information available in the as-built drawings [3], a post-tension force of 152 kips per each transverse post-tension bar was used for the analysis. The rigid links were used in the anchor plate area for transverse post-tensioning bars to get reasonable boundary effects (**Figure 2-6**). According to

I-90 Homer Hadley Floating Bridge – LRT Impacts		SC Solutions
Subject/Description: <b>OCS Pole Load Analysis</b>	Originator: H.J. Lee	Date: 8/6/08
	Checked: Hassan Sedarat	Date: 8/6/08
Disclaimer: The analysis in this technical document is preliminary and is strictly to be used as advice in determining the feasibility of placing the LRT on the Homer Hadley Floating Bridge and approach spans. It is not intended for any other purpose or as the basis for any final design or construction issue associated with this project.	Calculation No.:TM-01	
	Rev No.: 0	Sheet 6 of 40

technical memorandum by INCA [4], no longitudinal post-tension bars were used in the roadway deck. Self weight of the structure was assumed to be 160 lb/ft<sup>3</sup> based on concrete weight.

## 2.6 OCS Model Material Properties

Since a linear elastic analysis was performed, Young's modulus (E) = 4030.5 ksi and Poisson's ratio ( $\nu$ ) = 0.15 of concrete were necessary for material property input data. Since the same concrete material properties were used for all concrete elements, a change in the Young's modulus value does not affect stress magnitude values.

## 2.7 Cantilever Model Development

A cantilever model was also analyzed to investigate stresses at the critical regions under combined self weight, post-tension forces, OCS pole loads, and light rail vehicle loads. The main objective of the cantilever model was to figure out the effects of light rail vehicle loads. The substructure model boundary of the cantilever model is shown in **Figure 2-8**. The cantilever model extended the OCS pole model and has an outer wall and one light rail track. The cantilever model includes the modeling details of the OCS pole model. On top of that, the cantilever model has vertical and longitudinal post tension-bars and is subjected to light rail vehicle loads.

## 2.8 Cantilever Model Load and Boundary Conditions

Load and boundary conditions of the cantilever model are shown in **Figure 2-9**. The bottom of the wall and the inner side end of the deck were fixed against all translations. The longitudinal ends of the cantilever model were fixed against longitudinal translation. For the light rail vehicle loads, a portion of axle loads, 27.7<sup>k</sup> spaced at 5.58 ft shown in **Figure 2-10** were applied to the cantilever model. This axle loads were divided by two wheels and furthermore by plinth blocks. A simple beam analysis shown in **Figure 2-11** was performed to get a proper load distribution between plinth blocks. An axle load was placed on the top of one plinth block to get a concentrated local force acting on a plinth block. By doing this way, the light rail vehicle loads were applied to the deck through

<b>I-90 Homer Hadley Floating Bridge – LRT Impacts</b>		<b>SC Solutions</b>
<b>Subject/Description:</b> <b>OCS Pole Load Analysis</b>	Originator: H.J. Lee	Date: 8/6/08
	Checked: Hassan Sedarat	Date: 8/6/08
Disclaimer: The analysis in this technical document is preliminary and is strictly to be used as advice in determining the feasibility of placing the LRT on the Homer Hadley Floating Bridge and approach spans. It is not intended for any other purpose or as the basis for any final design or construction issue associated with this project.	Calculation No.:TM-01	
	Rev No.: 0	Sheet 7 of 40

plinth blocks. Each plinth block includes many nodes of solid elements and thus loads were well distributed to minimize boundary effects related to the light rail vehicle loads. The other modeling techniques of the cantilever model were same as those of the OCS pole model. The material properties of the cantilever model were the same as those of the OCS pole model.

## 2.9 Load Cases considered for the Cantilever Model

The following two different loading cases were analyzed in the analysis of the cantilever model:

- Case 1: 1.3 (Self weight + Vertical light rail vehicle load + Transverse light rail vehicle load + OCS pole load) + Post-tensioning forces
- Case 2: 1.3 (Self weight + Vertical light rail vehicle load + Transverse light rail vehicle load) + Post-tensioning forces

Case 1 includes both the light rail vehicle load and OCS pole load and for Case 2, OCS pole loads were excluded. A load factor of 1.3 was applied to the cantilever model except post-tensioning forces. It was assumed that post-tensioning forces are related to resistance and thus the load factor was not used for post-tensioning forces. Transverse light rail vehicle load was assumed to be 10 % of the vertical light rail vehicle load based on the report by INCA [4]. Transverse light rail vehicle load was applied in the direction to produce tension in the roadway deck for conservative prediction.



# I-90 Homer Hadley Floating Bridge – LRT Impacts

SC Solutions

Subject/Description:  
**OCS Pole Load Analysis**

Originator: H.J. Lee  
Checked: Hassan Sedarat

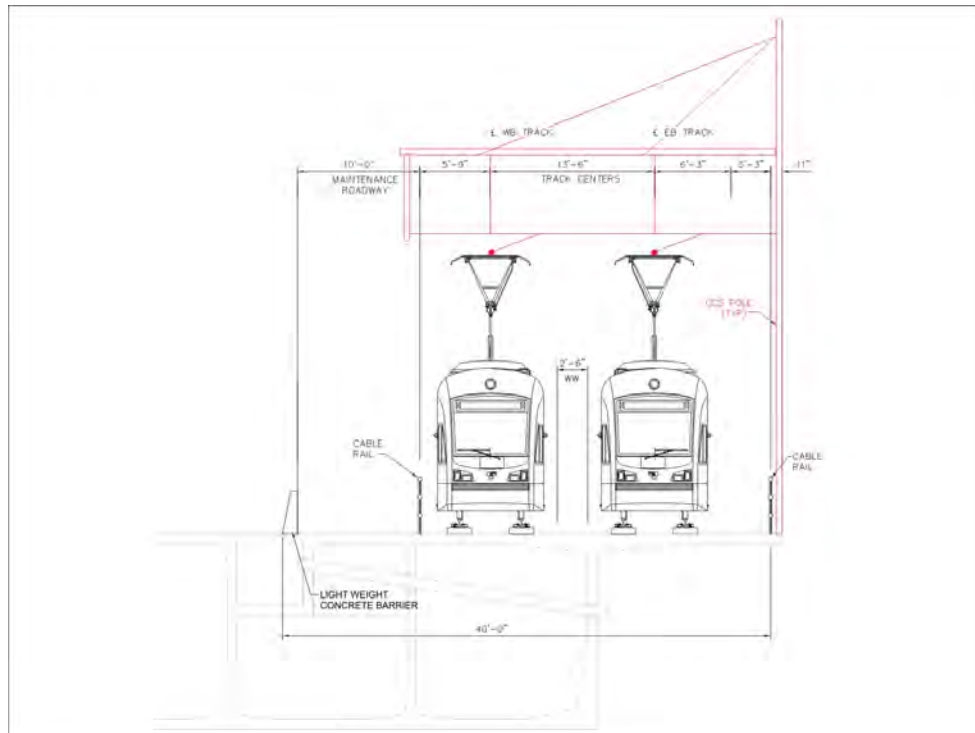
Date: 8/6/08  
Date: 8/6/08

Disclaimer: The analysis in this technical document is preliminary and is strictly to be used as advice in determining the feasibility of placing the LRT on the Homer Hadley Floating Bridge and approach spans. It is not intended for any other purpose or as the basis for any final design or construction issue associated with this project.

Calculation No.: TM-01

Rev No.: 0

Sheet 8 of 40



Subject/Description:  
**OCS Pole Load Analysis**

Originator: H.J. Lee

Date: 8/6/08

Checked: Hassan  
Sedarat

Date: 8/6/08

Disclaimer: The analysis in this technical document is preliminary and is strictly to be used as advice in determining the feasibility of placing the LRT on the Homer Hadley Floating Bridge and approach spans. It is not intended for any other purpose or as the basis for any final design or construction issue associated with this project.

Calculation No.:TM-01

Rev No.: 0

Sheet 9 of 40

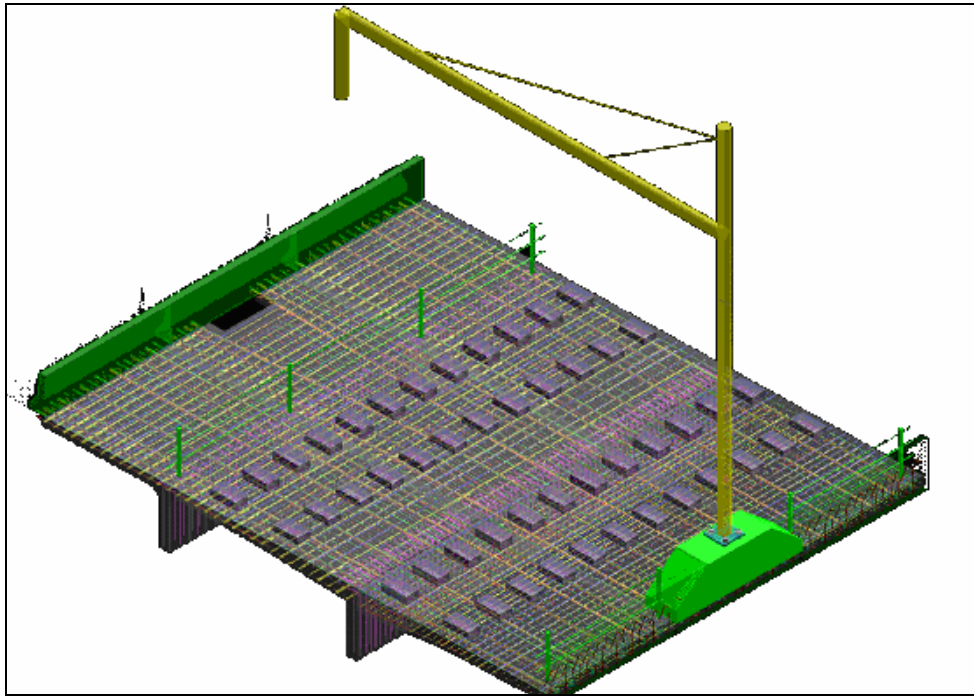


Figure 2-1: Two-Track OCS Cantilever Structure (Parsons and INCA [1])

Subject/Description:  
**OCS Pole Load Analysis**

Originator: H.J. Lee      Date: 8/6/08  
 Checked: Hassan          Date: 8/6/08  
 Sedarat

Disclaimer: The analysis in this technical document is preliminary and is strictly to be used as advice in determining the feasibility of placing the LRT on the Homer Hadley Floating Bridge and approach spans. It is not intended for any other purpose or as the basis for any final design or construction issue associated with this project.

Calculation No.: TM-01

Rev No.: 0                      Sheet 10 of 40

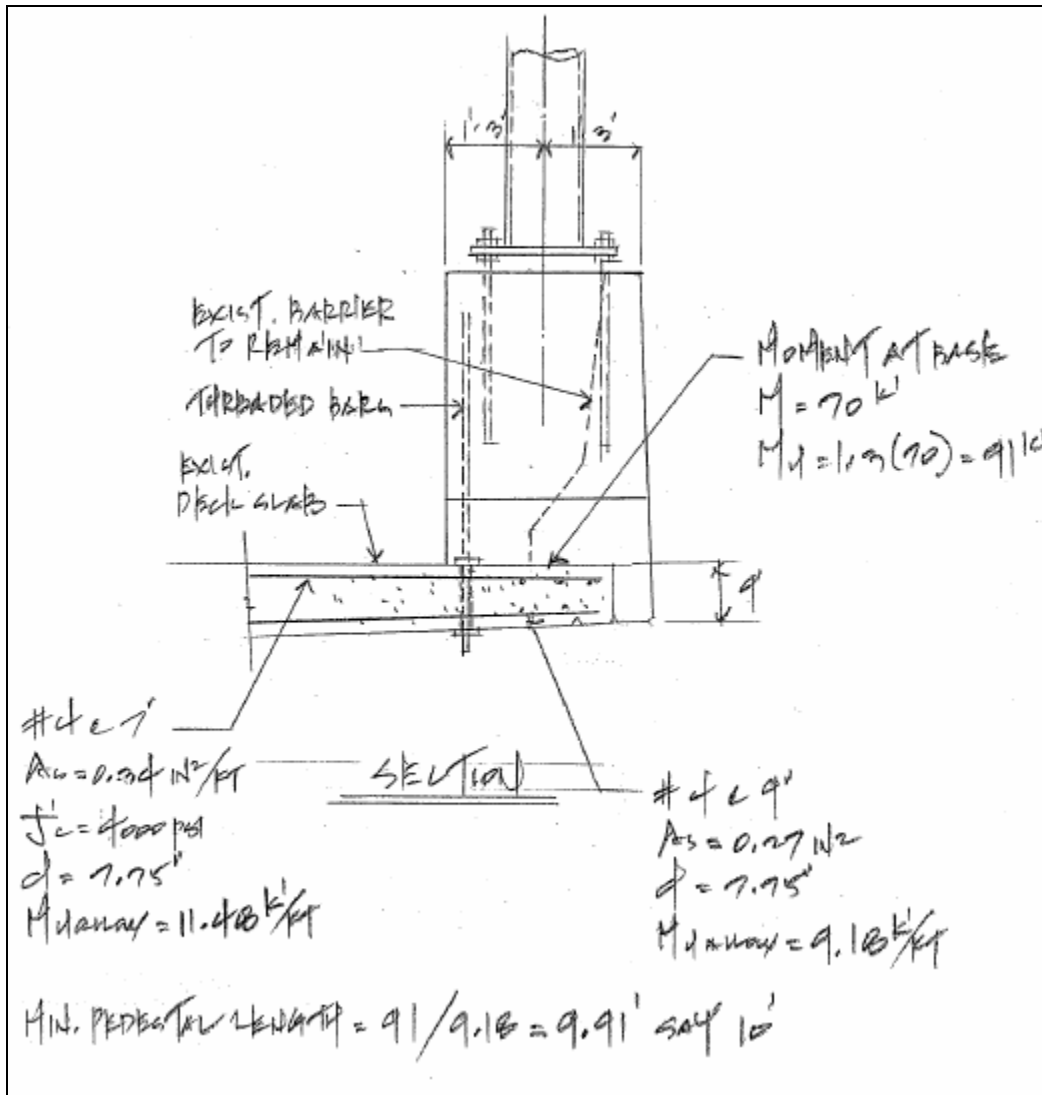


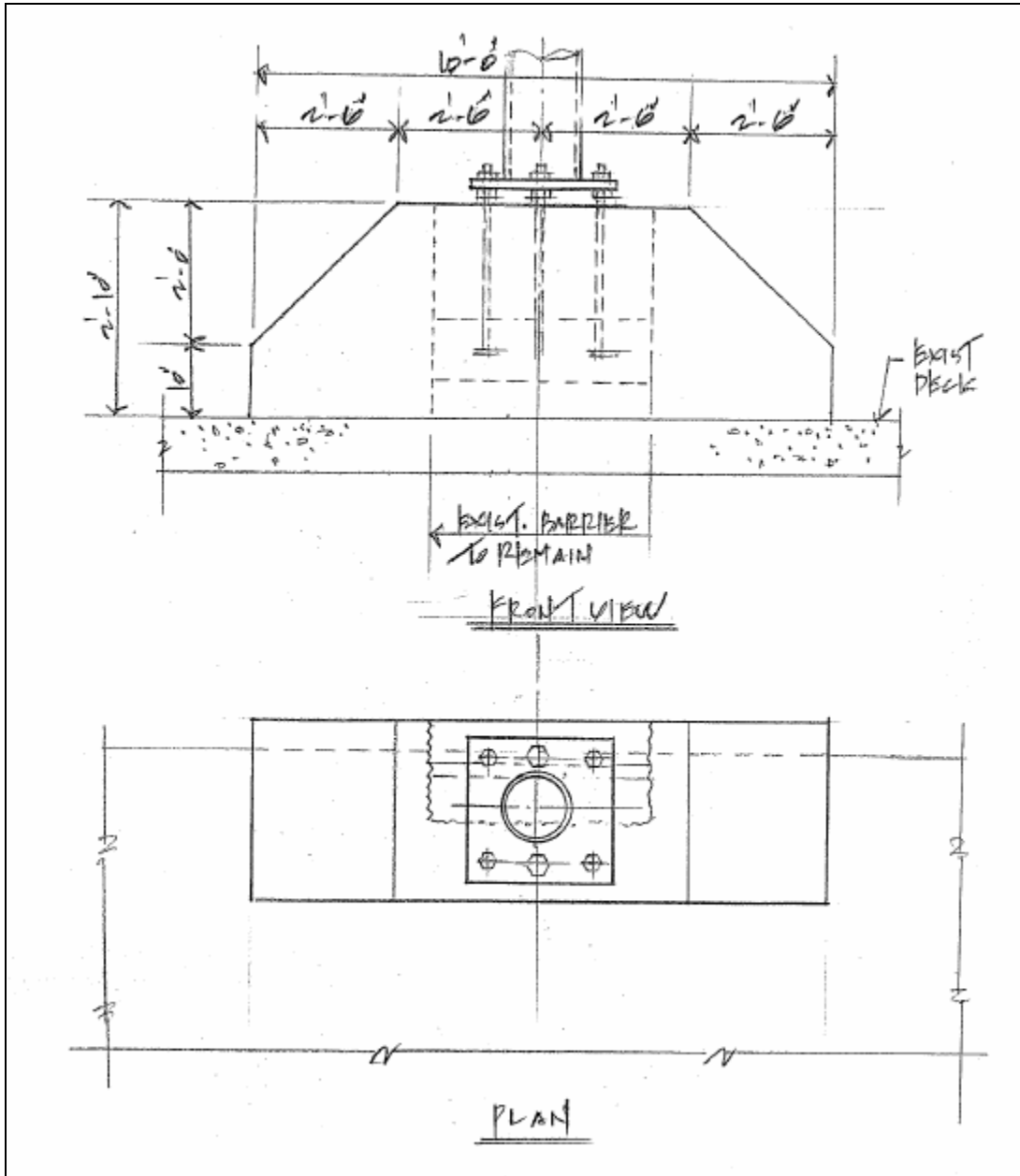
Figure 2-2: An OCS Anchor Block Design by INCA [5] Analyzed in This Study – Sectional View

Subject/Description:  
**OCS Pole Load Analysis**

Originator: H.J. Lee      Date: 8/6/08  
 Checked: Hassan          Date: 8/6/08  
 Sedarat

Disclaimer: The analysis in this technical document is preliminary and is strictly to be used as advice in determining the feasibility of placing the LRT on the Homer Hadley Floating Bridge and approach spans. It is not intended for any other purpose or as the basis for any final design or construction issue associated with this project.

Calculation No.: TM-01  
 Rev No.: 0                      Sheet 11 of 40



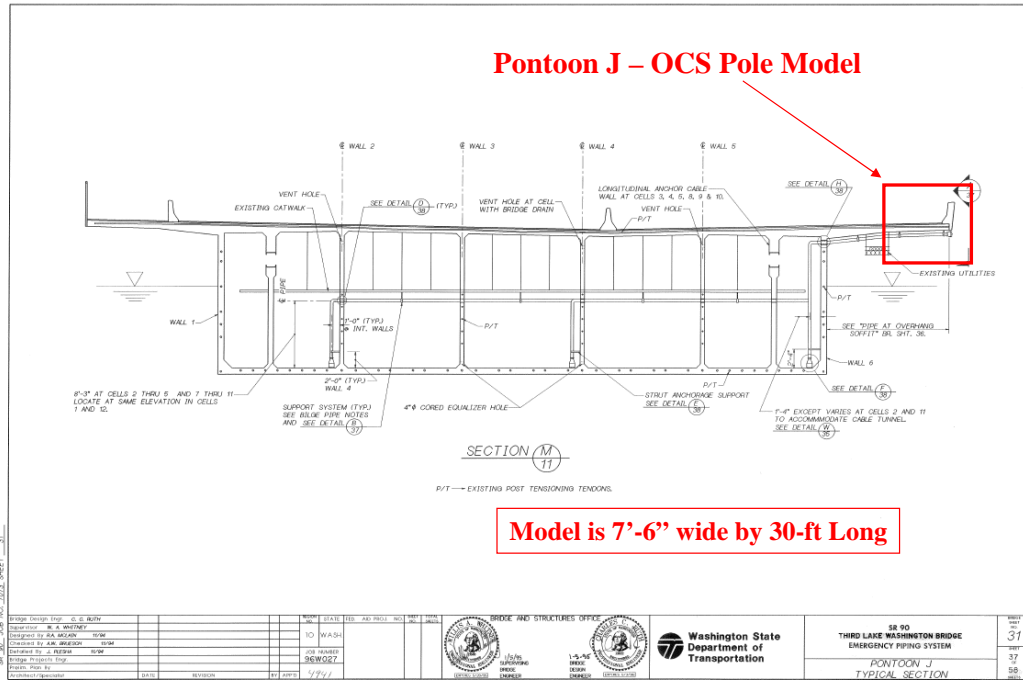
**Figure 2-3: An OCS Anchor Block Design by INCA [5] Analyzed in This Study – Front View and Plan View**

Subject/Description:  
**OCS Pole Load Analysis**

Originator: H.J. Lee      Date: 8/6/08  
 Checked: Hassan      Date: 8/6/08  
 Sedarat

Disclaimer: The analysis in this technical document is preliminary and is strictly to be used as advice in determining the feasibility of placing the LRT on the Homer Hadley Floating Bridge and approach spans. It is not intended for any other purpose or as the basis for any final design or construction issue associated with this project.

Calculation No.: TM-01  
 Rev No.: 0      Sheet 12 of 40



**Figure 2-4: Substructure Model Boundary selected for OCS Pole Analysis**

Subject/Description:  
**OCS Pole Load Analysis**

Originator: H.J. Lee  
 Checked: Hassan Sedarat

Date: 8/6/08  
 Date: 8/6/08

Disclaimer: The analysis in this technical document is preliminary and is strictly to be used as advice in determining the feasibility of placing the LRT on the Homer Hadley Floating Bridge and approach spans. It is not intended for any other purpose or as the basis for any final design or construction issue associated with this project.

Calculation No.:TM-01

Rev No.: 0

Sheet 13 of 40

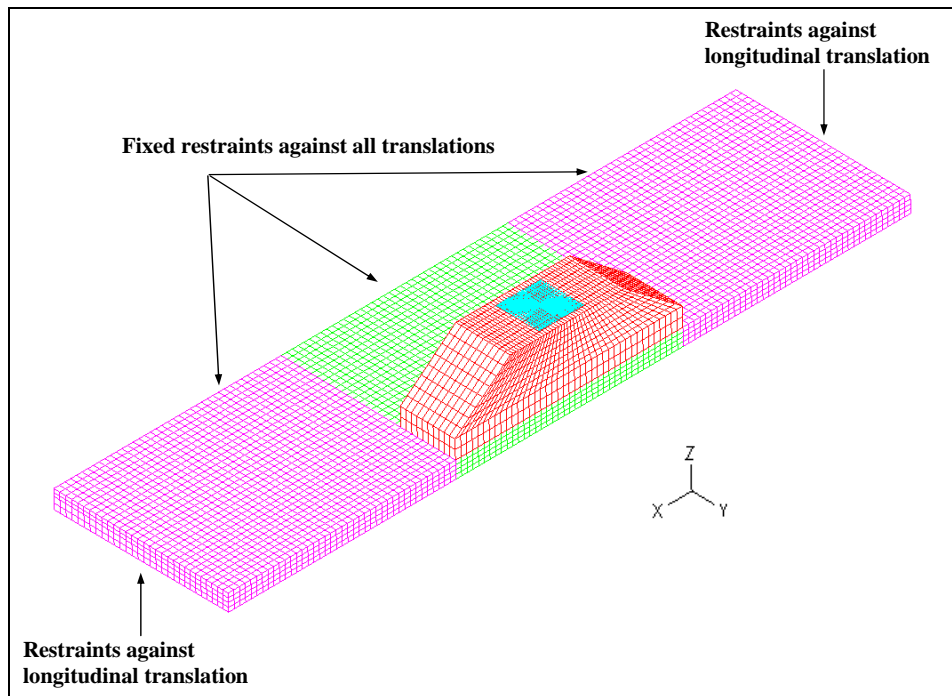
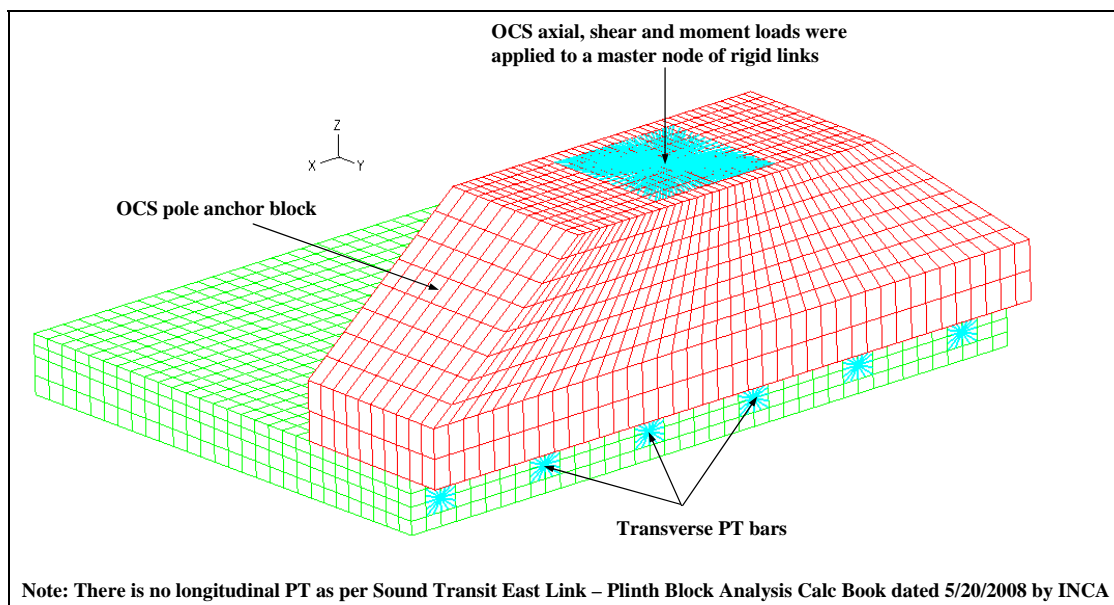


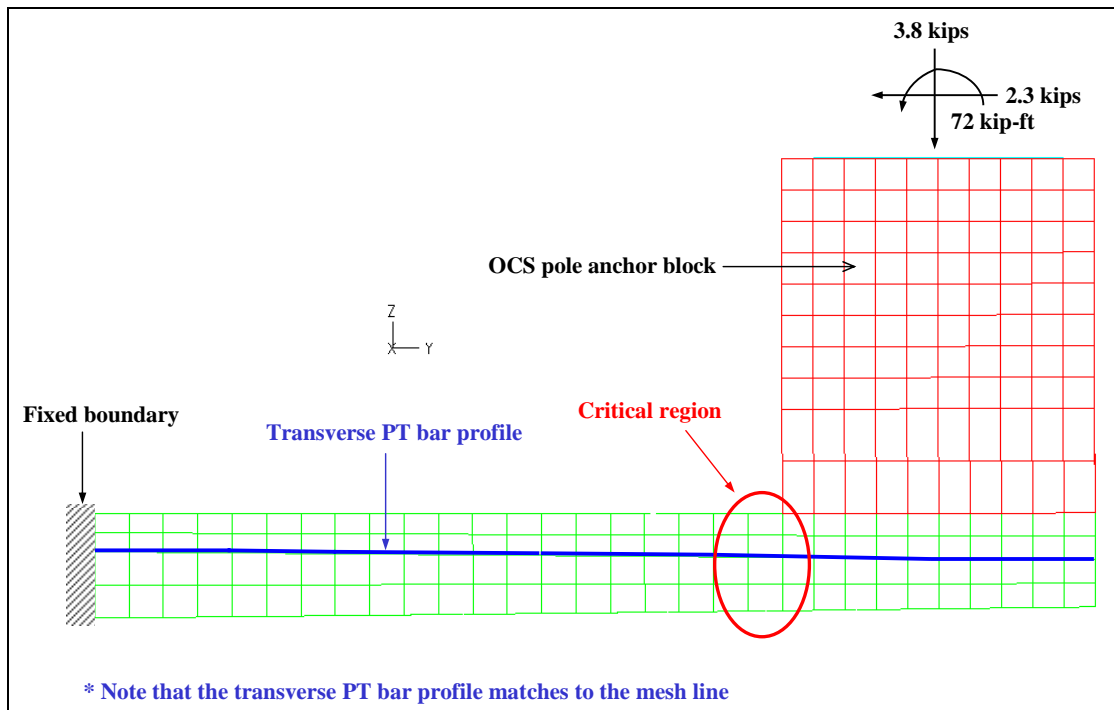
Figure 2-5: Finite Element Model for OCS Pole Analysis (7'-6" wide by 30-ft long)



Note: There is no longitudinal PT as per Sound Transit East Link – Plinth Block Analysis Calc Book dated 5/20/2008 by INCA

<b>I-90 Homer Hadley Floating Bridge – LRT Impacts</b>		<b>SC Solutions</b>
<b>Subject/Description:</b> <b>OCS Pole Load Analysis</b>	Originator: H.J. Lee	Date: 8/6/08
	Checked: Hassan Sedarat	Date: 8/6/08
Disclaimer: The analysis in this technical document is preliminary and is strictly to be used as advice in determining the feasibility of placing the LRT on the Homer Hadley Floating Bridge and approach spans. It is not intended for any other purpose or as the basis for any final design or construction issue associated with this project.	Calculation No.:TM-01	
	Rev No.: 0	Sheet 14 of 40

**Figure 2-6: Transverse PT Bar Locations and OCS Loading Location**



**Figure 2-7: Transverse PT Bar Profile and Critical Zone Location**

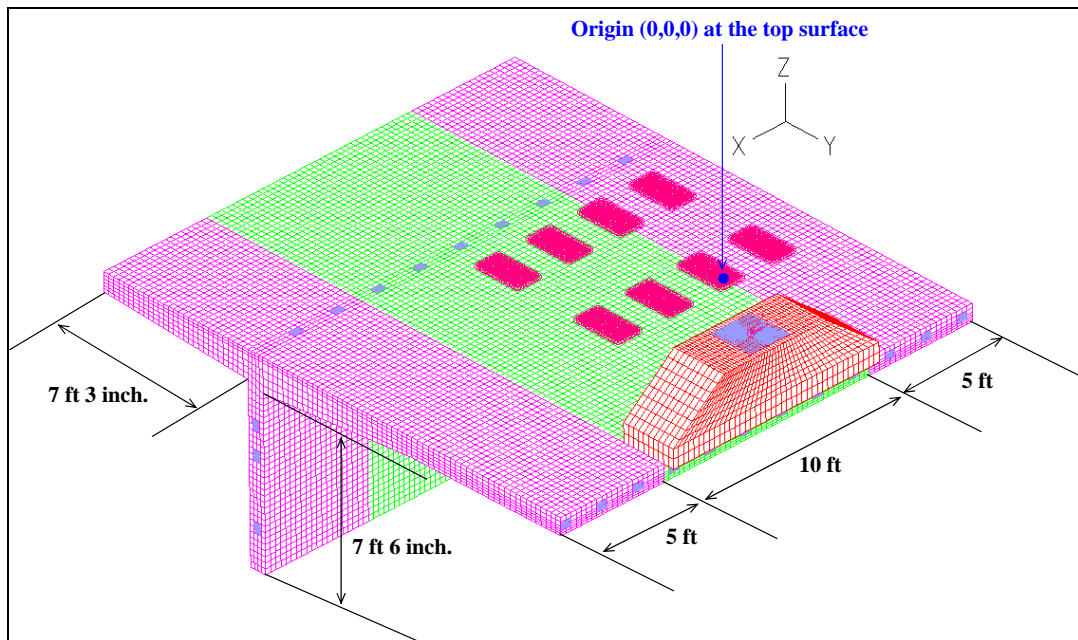
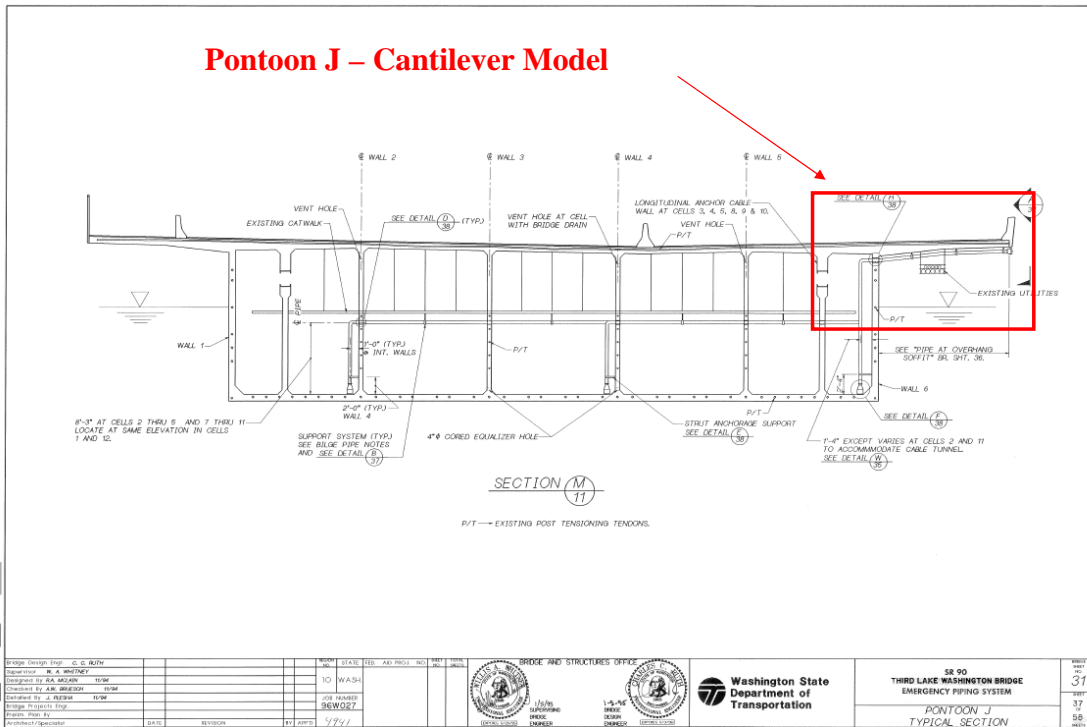
Subject/Description:  
**OCS Pole Load Analysis**

Originator: H.J. Lee      Date: 8/6/08  
 Checked: Hassan      Date: 8/6/08  
 Sedarat

Disclaimer: The analysis in this technical document is preliminary and is strictly to be used as advice in determining the feasibility of placing the LRT on the Homer Hadley Floating Bridge and approach spans. It is not intended for any other purpose or as the basis for any final design or construction issue associated with this project.

Calculation No.: TM-01

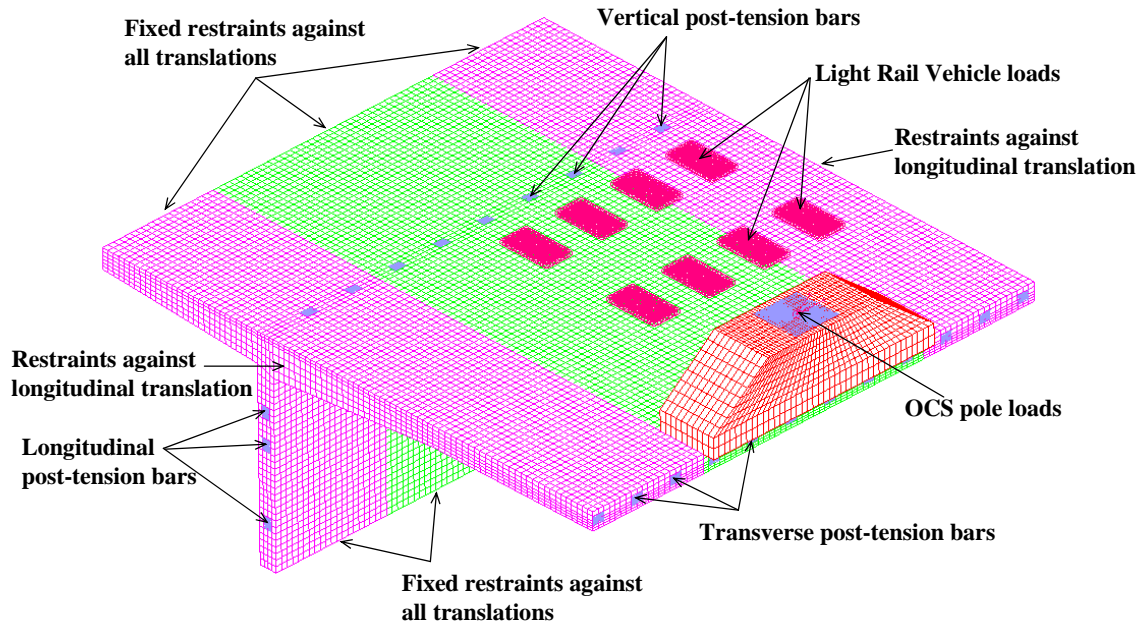
Rev No.: 0      Sheet 15 of 40



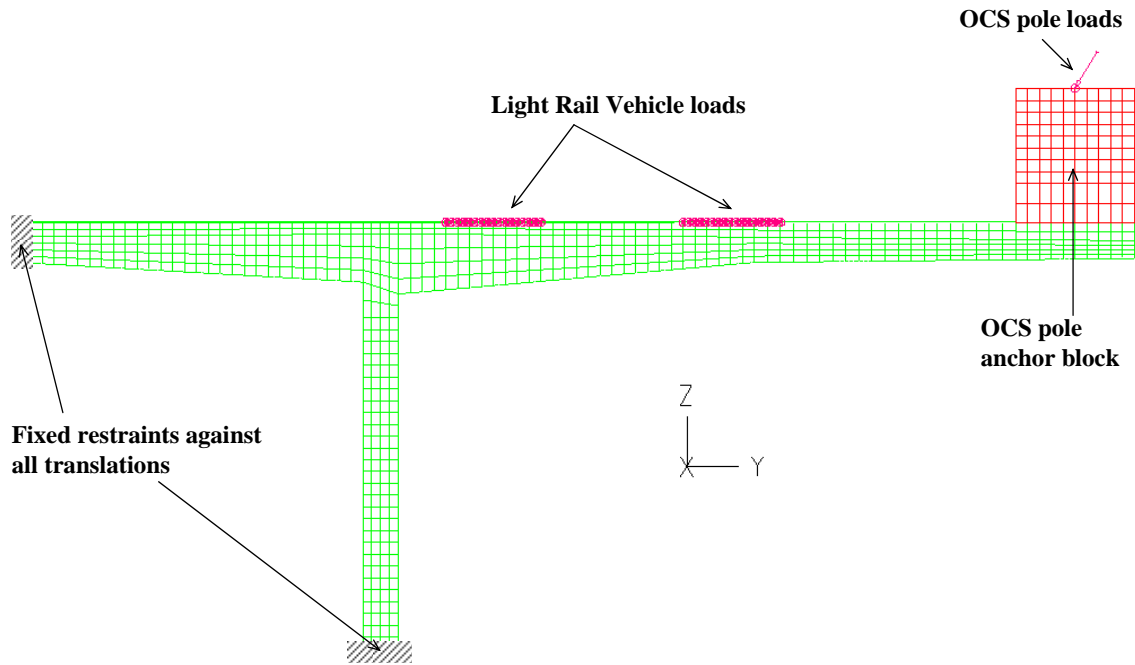


<b>I-90 Homer Hadley Floating Bridge – LRT Impacts</b>		<b>SC Solutions</b>
<b>Subject/Description:</b> <b>OCS Pole Load Analysis</b>	Originator: H.J. Lee	Date: 8/6/08
	Checked: Hassan Sedarat	Date: 8/6/08
Disclaimer: The analysis in this technical document is preliminary and is strictly to be used as advice in determining the feasibility of placing the LRT on the Homer Hadley Floating Bridge and approach spans. It is not intended for any other purpose or as the basis for any final design or construction issue associated with this project.	Calculation No.:TM-01	
	Rev No.: 0	Sheet 16 of 40

**Figure 2-8: Substructure Model Boundary of a Cantilever Model**

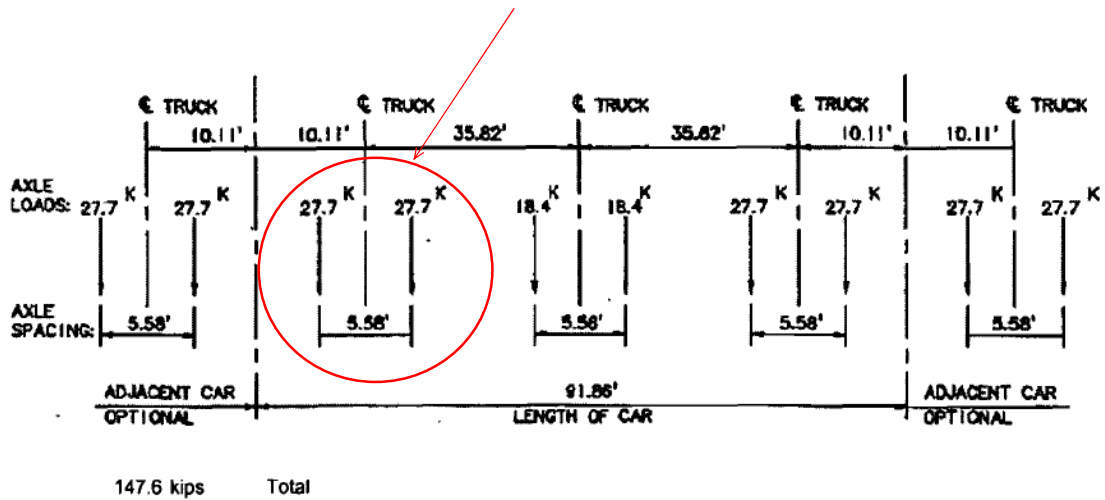


<b>I-90 Homer Hadley Floating Bridge – LRT Impacts</b>		<b>SC Solutions</b>
<b>Subject/Description:</b> <b>OCS Pole Load Analysis</b>	Originator: H.J. Lee	Date: 8/6/08
	Checked: Hassan Sedarat	Date: 8/6/08
Disclaimer: The analysis in this technical document is preliminary and is strictly to be used as advice in determining the feasibility of placing the LRT on the Homer Hadley Floating Bridge and approach spans. It is not intended for any other purpose or as the basis for any final design or construction issue associated with this project.	Calculation No.: TM-01	
	Rev No.: 0	Sheet 17 of 40



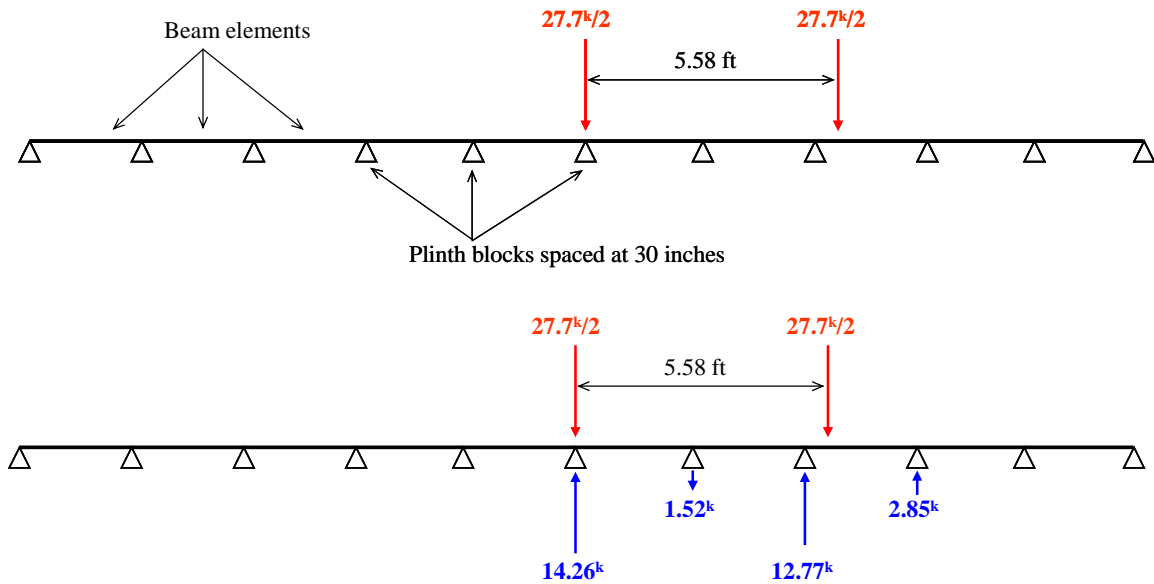
**Figure 2-9: Loading and Boundary Conditions of a Cantilever Model**

Loads considered in the Cantilever Model of this study



I-90 Homer Hadley Floating Bridge – LRT Impacts		SC Solutions
Subject/Description: <b>OCS Pole Load Analysis</b>	Originator: H.J. Lee	Date: 8/6/08
	Checked: Hassan Sedarat	Date: 8/6/08
Disclaimer: The analysis in this technical document is preliminary and is strictly to be used as advice in determining the feasibility of placing the LRT on the Homer Hadley Floating Bridge and approach spans. It is not intended for any other purpose or as the basis for any final design or construction issue associated with this project.	Calculation No.:TM-01	
	Rev No.: 0	Sheet 18 of 40

**Figure 2-10: Light Rail Vehicle Design Load included in the Cantilever Model**



**Figure 2-11: Forces acting on the Plinth Blocks under Light Rail Vehicle Loading**

### 3. Discussion

#### 3.1 OCS Model Analysis Results

Stress values were extracted at the element centroid of the middle 10-ft zone shown in **Figure 3-1**. According to analysis results, transverse stress ( $S_{yy}$ ) and longitudinal stress ( $S_{xx}$ ) values are negative (compressive) in most of the regions except locations under severe boundary effects (**Figure 3-2** and **Figure 3-3**). Boundary effects related to post-tension forces quickly decays and are small at the region near the inner edge of the OCS anchor block. The maximum principal tensile stresses ( $S_{p1}$ ) at some regions below the OCS anchor block show tensile values (**Figure 3-4**), but the stress magnitude is less than

I-90 Homer Hadley Floating Bridge – LRT Impacts		SC Solutions
Subject/Description: <b>OCS Pole Load Analysis</b>	Originator: H.J. Lee	Date: 8/6/08
	Checked: Hassan Sedarat	Date: 8/6/08
Disclaimer: The analysis in this technical document is preliminary and is strictly to be used as advice in determining the feasibility of placing the LRT on the Homer Hadley Floating Bridge and approach spans. It is not intended for any other purpose or as the basis for any final design or construction issue associated with this project.	Calculation No.:TM-01	
	Rev No.: 0	Sheet 19 of 40

a stress limit ( $2\sqrt{f'_c}=2\sqrt{5000} = 141$  psi ) based on concrete design strength of  $f'_c = 5000$  psi . It was found that tensile stress values at the roadway surface are very small. According to test results on core drilled concrete specimens by Mayes Testing Engineers [6], concrete strength of  $f'_c$  was 7090 psi and thus, the allowable stress can be increased to  $2\sqrt{f'_c}=2\sqrt{7090} = 168$  psi . This increased concrete strength gives additional margin for bridge safety.

### 3.2 Cantilever Model Analysis Results – Stress Values

Stress values at the critical zones of the cantilever model shown in **Figure 3-5** were investigated. Principal tensile stress contour plots at the surfaces of the wall and the deck shown in **Figure 3-6** were generated in the middle 10-ft zone.

#### 3.2.1 Case 1 with OCS Pole Loads

For Case 1 with OCS pole loads, maximum principal tensile stress ( $Sp_1$ ) variations in the x-direction at the wall critical sections are presented in **Figure 3-7** and **Figure 3-8**. No tensile stresses are observed at element centroids. It was found that vertical normal stresses ( $S_{zz}$ ) are compressive at the element centroids of the wall critical sections. Maximum principal tensile stress ( $Sp_1$ ) variations in the x-direction at the deck critical sections are presented in **Figure 3-9** and **Figure 3-10**. There are significant local effects related to vertical post-tensioning forces. However, principal tensile stress values at element centroids are less than a design stress limit ( $2\sqrt{f'_c}=2\sqrt{5000} = 141$  psi ) and a stress limit ( $2\sqrt{f'_c}=2\sqrt{7090} = 168$  psi ) based on test results by Mayes Testing Engineers [6]. It was found that transverse normal stresses ( $S_{yy}$ ) are compressive at the element centroids of the deck critical sections.

#### 3.2.2 Case 2 without OCS Pole Loads

For Case 2 without OCS pole loads, maximum principal tensile stress ( $Sp_1$ ) variations in the x-direction at the wall critical sections are presented in **Figure 3-11** and **Figure 3-12**.

I-90 Homer Hadley Floating Bridge – LRT Impacts		SC Solutions
Subject/Description: <b>OCS Pole Load Analysis</b>	Originator: H.J. Lee	Date: 8/6/08
	Checked: Hassan Sedarat	Date: 8/6/08
Disclaimer: The analysis in this technical document is preliminary and is strictly to be used as advice in determining the feasibility of placing the LRT on the Homer Hadley Floating Bridge and approach spans. It is not intended for any other purpose or as the basis for any final design or construction issue associated with this project.	Calculation No.:TM-01	
	Rev No.: 0	Sheet 20 of 40

No tensile stresses are observed at element centroids. It was found that vertical normal stresses ( $S_{zz}$ ) are compressive at the element centroids of the wall critical sections. Maximum principal tensile stress ( $S_{p1}$ ) variations in the x-direction at the deck critical sections are presented in **Figure 3-13** and **Figure 3-14**. There are significant local effects related to vertical post-tensioning forces. However, principal tensile stress values at element centroids are less than a design stress limit (141 psi) and a stress limit (168 psi) based on test results by Mayes Testing Engineers [6]. It was found that transverse normal stresses ( $S_{yy}$ ) are compressive at the element centroids of the deck critical sections.

### 3.3 Cantilever Model Analysis Results – Contour Plots

For the extensive investigation of stress values, the contour plots of the elements in the critical zones of the middle 10-ft zone were generated. In order to remove boundary effects, the middle 10-ft zone was used for the contour plots.

#### 3.3.1 Case 1 with OCS Pole Loads

For Case 1 with OCS pole loads, maximum principal tensile stress ( $S_{p1}$ ) contour plots at the inner and outer surfaces of the wall are shown in **Figure 3-15** and **Figure 3-16**, respectively. A maximum principal tensile stress of 0.1437 ksi at the inner surface of the wall is slightly larger than a design stress limit of 0.1414 ksi (demand/capacity ratio= 1.016), but is less than a stress limit (0.168 ksi) based on test results by Mayes Testing Engineers [6]. A maximum principal tensile stress of 0.1047 ksi at the outer surface of the wall is less than a design stress limit (0.141 ksi) and a stress limit (0.168 ksi) based on test results by Mayes Testing Engineers [6]. Maximum principal tensile stress ( $S_{p1}$ ) contour plots at the top and bottom surfaces of the deck are shown in **Figure 3-17** and **Figure 3-18**, respectively. There are high tensile stress values at the local zones related to vertical post-tensioning bars. These high tensile stress values are only local effects. The maximum principal tensile stress values at the top and bottom surfaces of the deck are 0.1079 ksi and 0.1288 ksi, respectively. These values are less than a design stress limit (0.141 ksi) and a stress limit (0.168 ksi) based on test results by Mayes Testing Engineers [6].

I-90 Homer Hadley Floating Bridge – LRT Impacts		SC Solutions
Subject/Description: <b>OCS Pole Load Analysis</b>	Originator: H.J. Lee	Date: 8/6/08
	Checked: Hassan Sedarat	Date: 8/6/08
Disclaimer: The analysis in this technical document is preliminary and is strictly to be used as advice in determining the feasibility of placing the LRT on the Homer Hadley Floating Bridge and approach spans. It is not intended for any other purpose or as the basis for any final design or construction issue associated with this project.	Calculation No.:TM-01	
	Rev No.: 0	Sheet 21 of 40

### 3.3.2 Case 2 without OCS Pole Loads

For Case 2 without OCS pole loads, maximum principal tensile stress (Sp1) contour plots at the inner and outer surfaces of the wall are shown in **Figure 3-19** and **Figure 3-20**, respectively. A maximum principal tensile stress of 0.1008 ksi at the inner surface of the wall is less than a design stress limit (0.141 ksi) and a stress limit (0.168 ksi) based on test results by Mayes Testing Engineers [6]. A maximum principal tensile stress of 0.08866 ksi at the outer surface of the wall is also less than a design stress limit (0.141 ksi) and a stress limit (0.168 ksi) based on test results by Mayes Testing Engineers [6]. Maximum principal tensile stress (Sp1) contour plots at the top and bottom surfaces of the deck are shown in **Figure 3-21** and **Figure 3-22**. There are high tensile stress values at the local zones related to vertical post-tensioning bars. These high tensile stress values are only local effects. The maximum principal tensile stress values at the top and bottom surfaces of the deck are 0.0813 ksi and 0.1239 ksi, respectively. These values are less than a design stress limit (0.141 ksi) and a stress limit (0.168 ksi) based on test results by Mayes Testing Engineers [6].

Subject/Description:  
**OCS Pole Load Analysis**

Originator: H.J. Lee  
 Checked: Hassan Sedarat

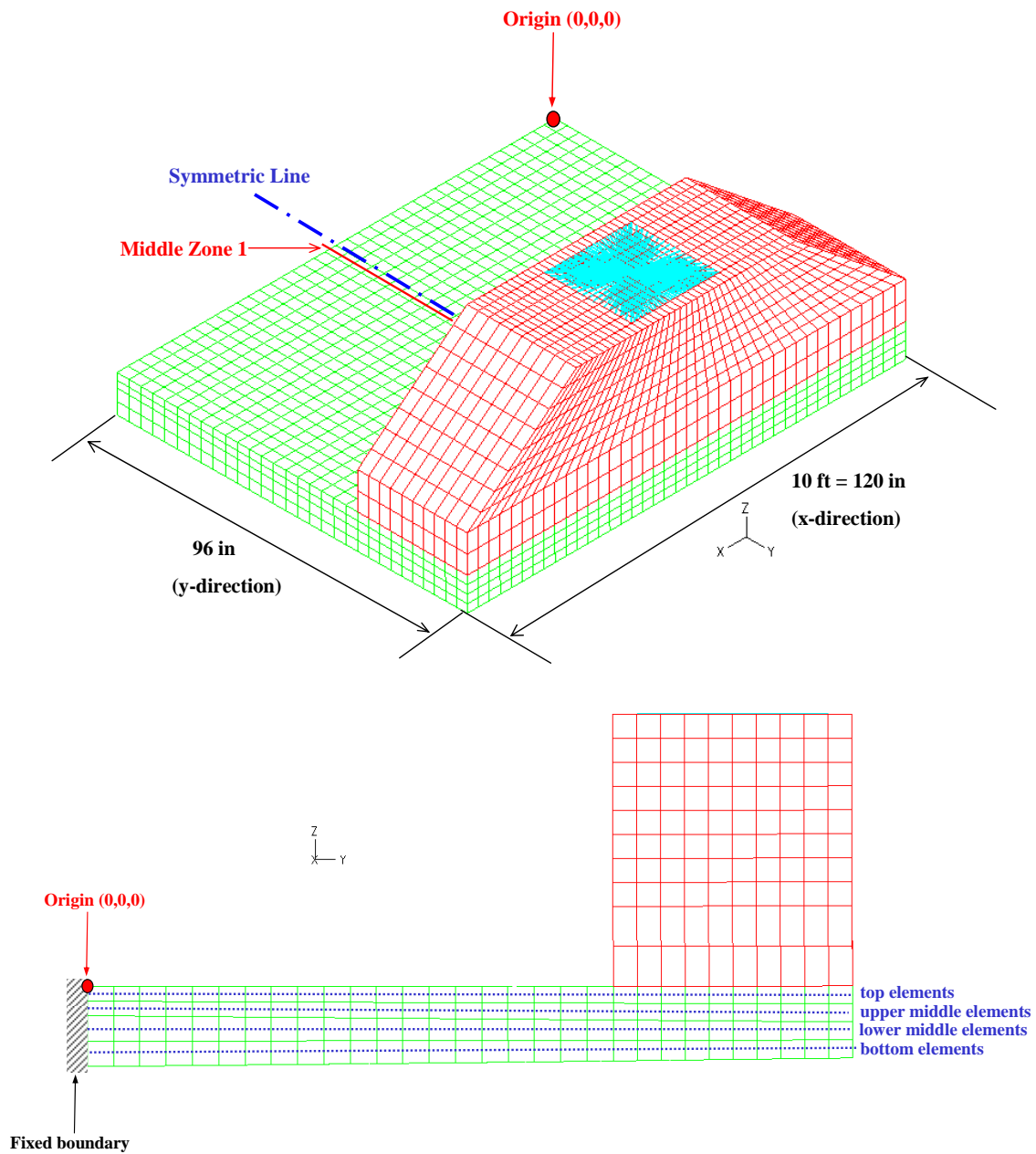
Date: 8/6/08  
 Date: 8/6/08

Disclaimer: The analysis in this technical document is preliminary and is strictly to be used as advice in determining the feasibility of placing the LRT on the Homer Hadley Floating Bridge and approach spans. It is not intended for any other purpose or as the basis for any final design or construction issue associated with this project.

Calculation No.:TM-01

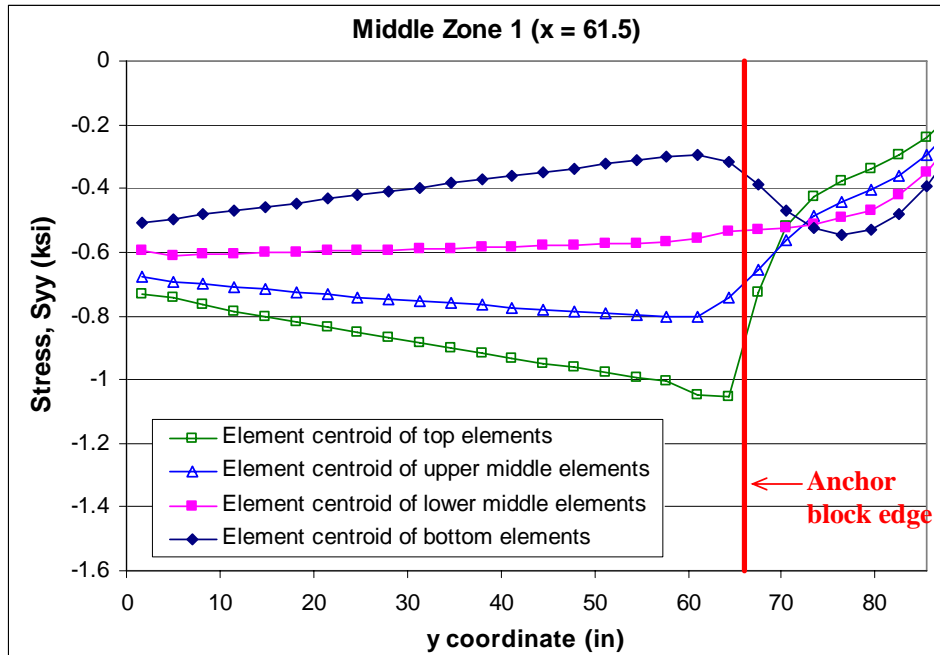
Rev No.: 0

Sheet 22 of 40



**Figure 3-1: Middle Zone Location selected for the Investigation of Stress Variation in the y-direction (x = 61.5)**

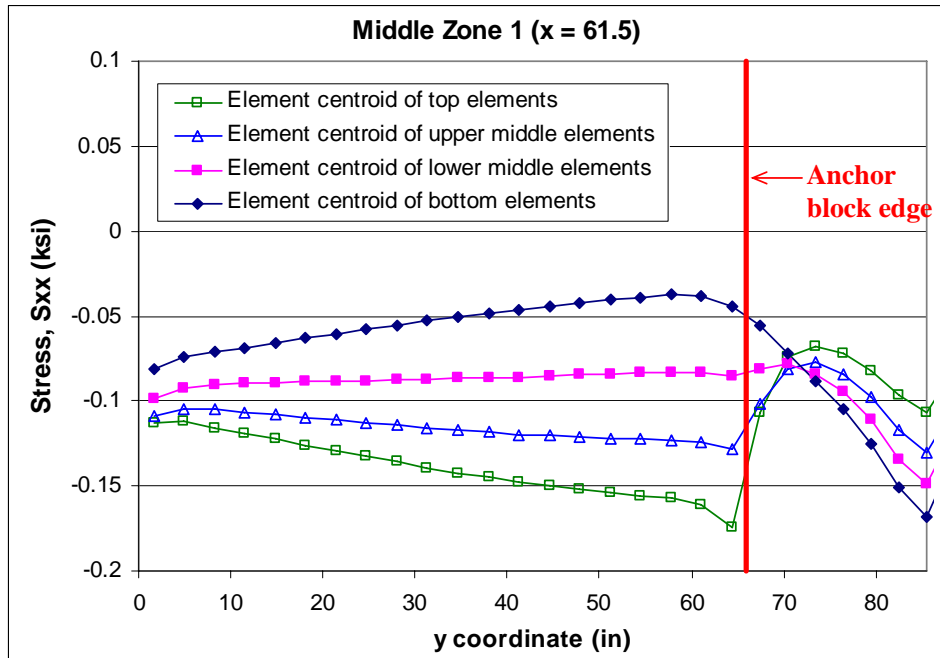
<b>I-90 Homer Hadley Floating Bridge – LRT Impacts</b>		<b>SC Solutions</b>
Subject/Description: <b>OCS Pole Load Analysis</b>	Originator: H.J. Lee	Date: 8/6/08
	Checked: Hassan Sedarat	Date: 8/6/08
Disclaimer: The analysis in this technical document is preliminary and is strictly to be used as advice in determining the feasibility of placing the LRT on the Homer Hadley Floating Bridge and approach spans. It is not intended for any other purpose or as the basis for any final design or construction issue associated with this project.	Calculation No.:TM-01	
	Rev No.: <b>0</b>	Sheet 23 of 40



**Figure 3-2: Transverse Stress (Syy) Variation in the y-direction**

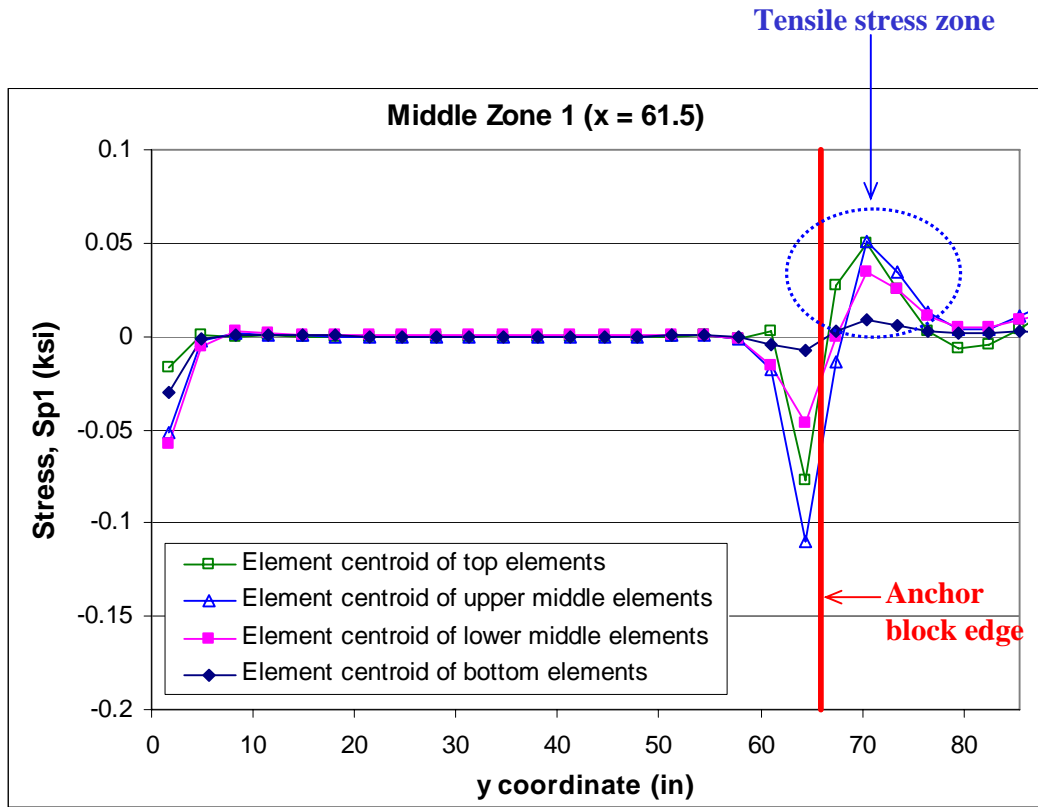


<b>I-90 Homer Hadley Floating Bridge – LRT Impacts</b>		<b>SC Solutions</b>
<b>Subject/Description:</b> <b>OCS Pole Load Analysis</b>	Originator: H.J. Lee	Date: 8/6/08
	Checked: Hassan Sedarat	Date: 8/6/08
Disclaimer: The analysis in this technical document is preliminary and is strictly to be used as advice in determining the feasibility of placing the LRT on the Homer Hadley Floating Bridge and approach spans. It is not intended for any other purpose or as the basis for any final design or construction issue associated with this project.	Calculation No.:TM-01	
	Rev No.: 0	Sheet 24 of 40



**Figure 3-3: Longitudinal Stress (Sxx) Variation in the y-direction**

<b>I-90 Homer Hadley Floating Bridge – LRT Impacts</b>		<b>SC Solutions</b>
<b>Subject/Description:</b> <b>OCS Pole Load Analysis</b>	Originator: H.J. Lee	Date: 8/6/08
	Checked: Hassan Sedarat	Date: 8/6/08
Disclaimer: The analysis in this technical document is preliminary and is strictly to be used as advice in determining the feasibility of placing the LRT on the Homer Hadley Floating Bridge and approach spans. It is not intended for any other purpose or as the basis for any final design or construction issue associated with this project.	Calculation No.:TM-01	
	Rev No.: 0	Sheet 25 of 40



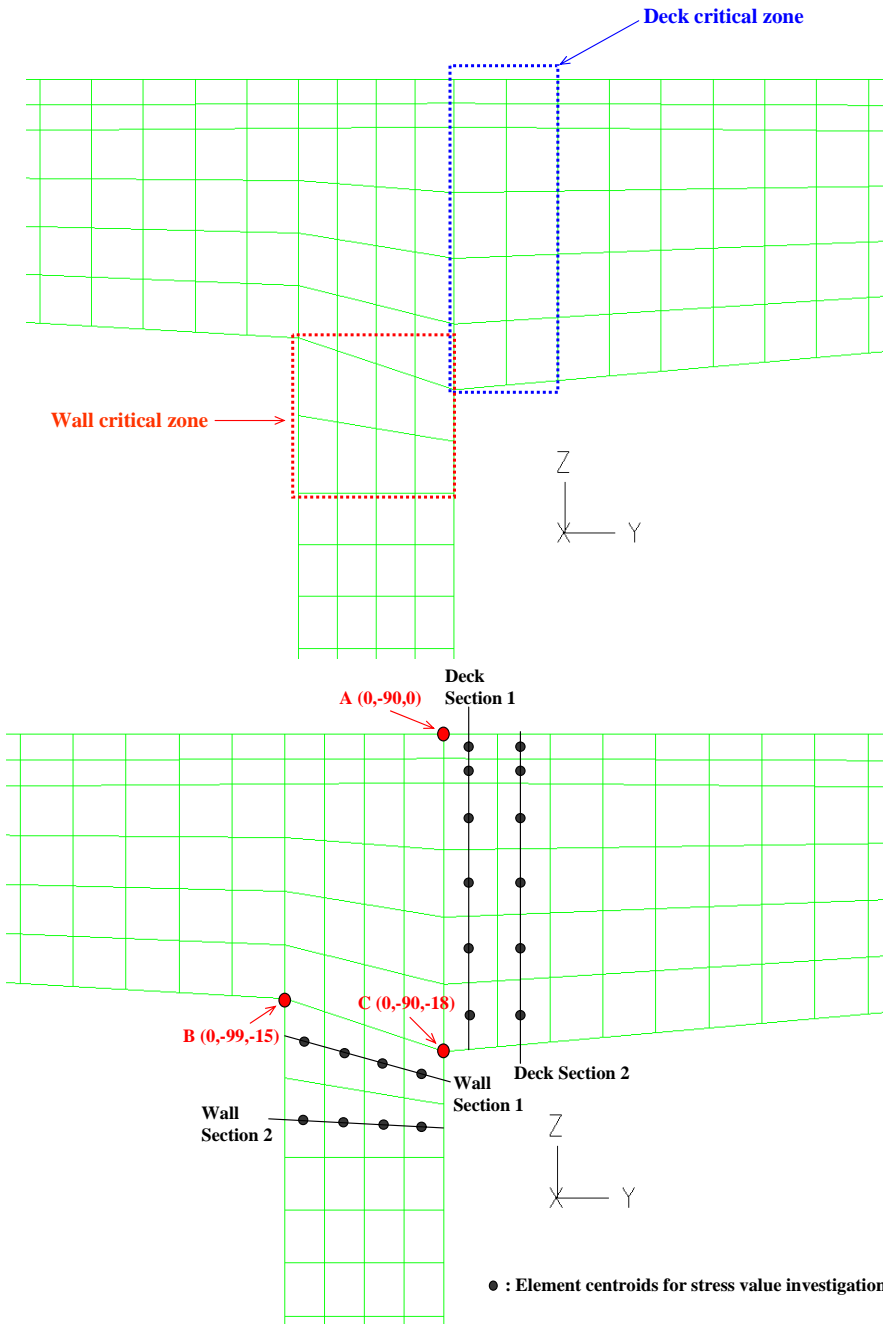
**Figure 3-4: Principal Tensile Stress (Sp1) Variation in the y-direction**

Subject/Description:  
**OCS Pole Load Analysis**

Originator: H.J. Lee      Date: 8/6/08  
 Checked: Hassan          Date: 8/6/08  
 Sedarat

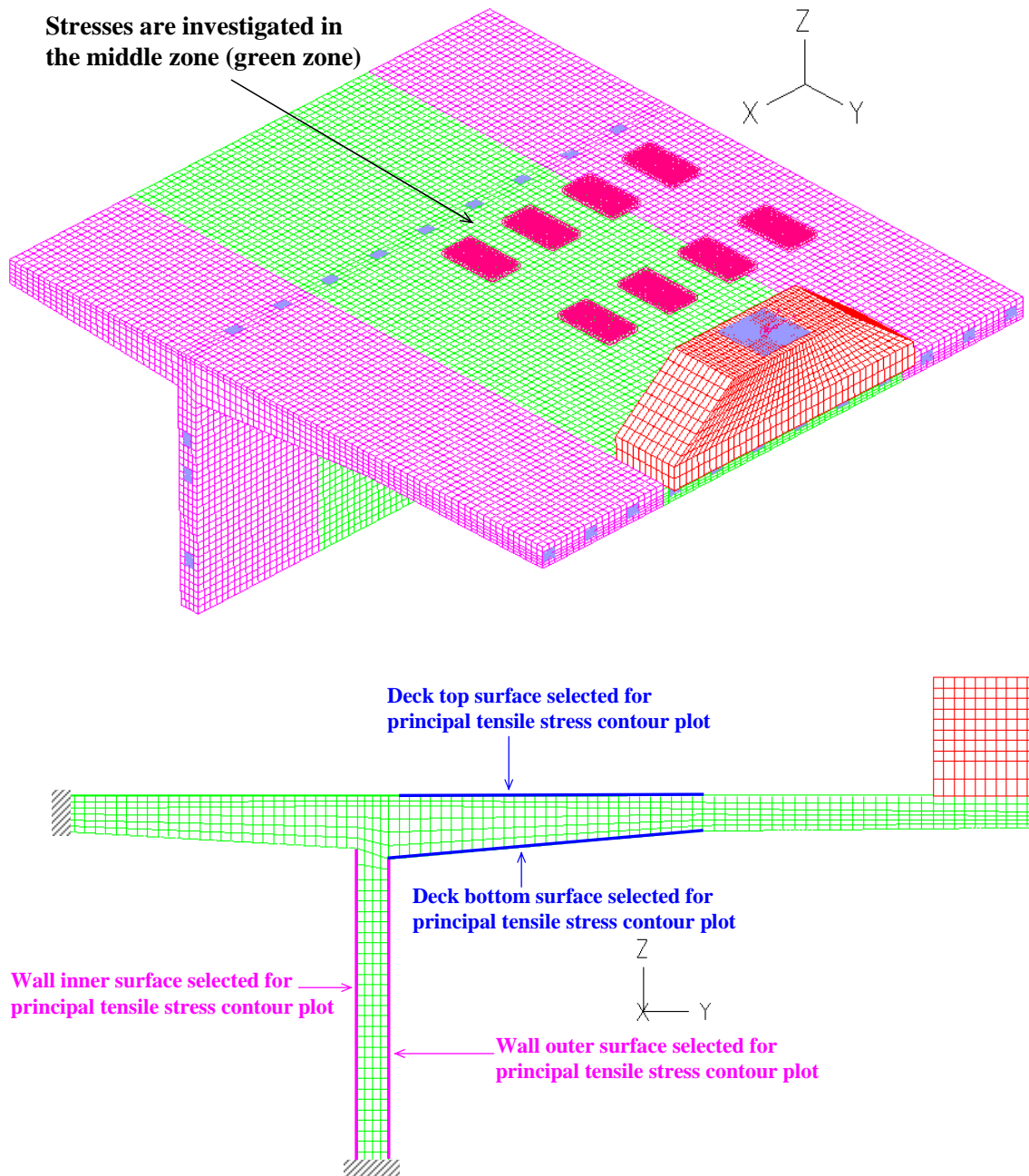
Disclaimer: The analysis in this technical document is preliminary and is strictly to be used as advice in determining the feasibility of placing the LRT on the Homer Hadley Floating Bridge and approach spans. It is not intended for any other purpose or as the basis for any final design or construction issue associated with this project.

Calculation No.:TM-01  
 Rev No.: **0**                      Sheet 26 of 40



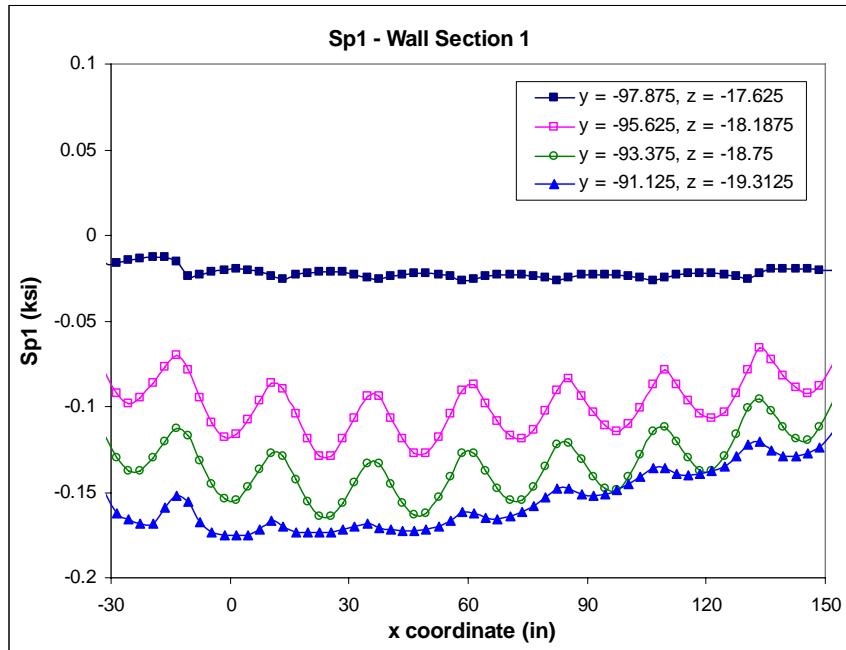
<b>I-90 Homer Hadley Floating Bridge – LRT Impacts</b>		<b>SC Solutions</b>
<b>Subject/Description:</b> <b>OCS Pole Load Analysis</b>	Originator: H.J. Lee	Date: 8/6/08
	Checked: Hassan Sedarat	Date: 8/6/08
Disclaimer: The analysis in this technical document is preliminary and is strictly to be used as advice in determining the feasibility of placing the LRT on the Homer Hadley Floating Bridge and approach spans. It is not intended for any other purpose or as the basis for any final design or construction issue associated with this project.	Calculation No.:TM-01	
	Rev No.: 0	Sheet 27 of 40

**Figure 3-5: Coordinate Reference Points and Critical Sections selected for Stress Value Investigation – Cantilever Model**



<b>I-90 Homer Hadley Floating Bridge – LRT Impacts</b>		<b>SC Solutions</b>
<b>Subject/Description:</b> <b>OCS Pole Load Analysis</b>	Originator: H.J. Lee	Date: 8/6/08
	Checked: Hassan Sedarat	Date: 8/6/08
Disclaimer: The analysis in this technical document is preliminary and is strictly to be used as advice in determining the feasibility of placing the LRT on the Homer Hadley Floating Bridge and approach spans. It is not intended for any other purpose or as the basis for any final design or construction issue associated with this project.	Calculation No.:TM-01	
	Rev No.: 0	Sheet 28 of 40

**Figure 3-6: Surface Zones selected for Principal Tensile Stress Contour Plots – Cantilever Model**



**Figure 3-7: Principal Tensile Stress Variation in the x-direction at Wall Section 1 – Self Weight +Post Tension Forces +Light Rail Vehicle Loads +OCS Loads (Case 1)**

Subject/Description:  
**OCS Pole Load Analysis**

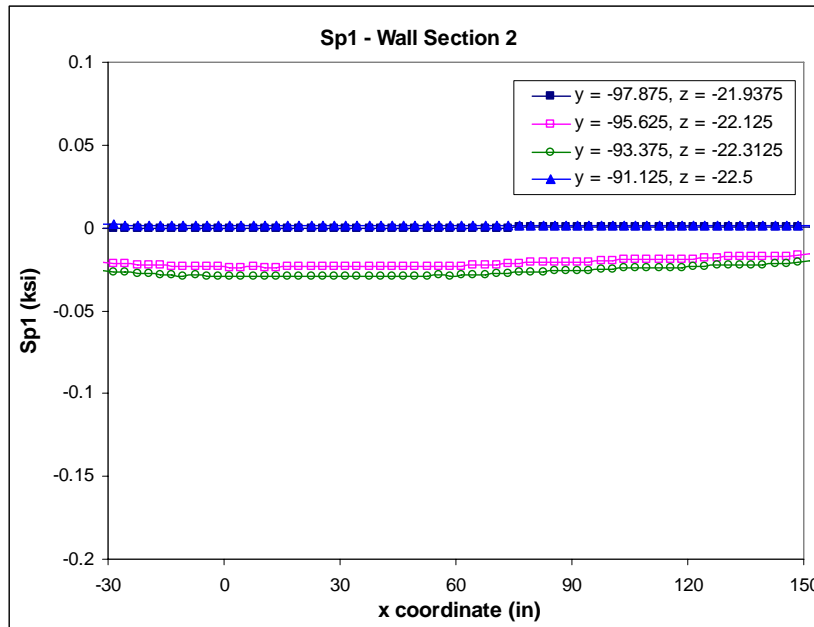
Originator: H.J. Lee      Date: 8/6/08

Checked: Hassan          Date: 8/6/08  
 Sedarat

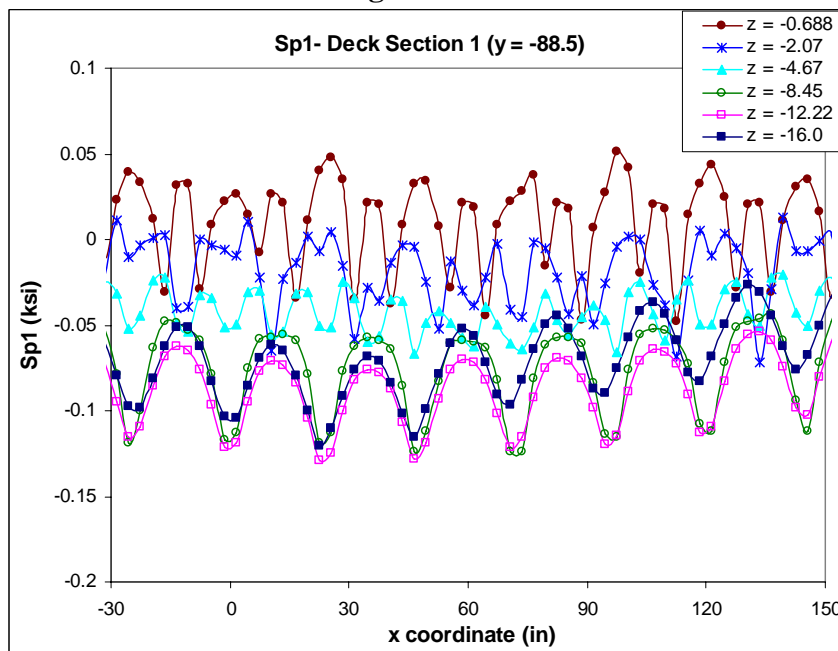
Disclaimer: The analysis in this technical document is preliminary and is strictly to be used as advice in determining the feasibility of placing the LRT on the Homer Hadley Floating Bridge and approach spans. It is not intended for any other purpose or as the basis for any final design or construction issue associated with this project.

Calculation No.:TM-01

Rev No.: **0**                      Sheet 29 of 40

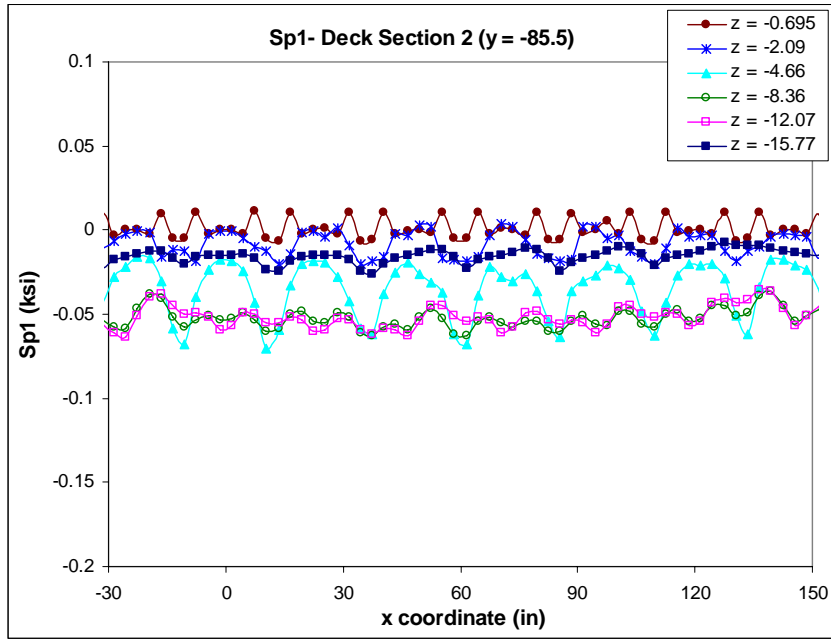


**Figure 3-8: Principal Tensile Stress Variation in the x-direction at Wall Section 2- Self Weight +Post Tension Forces +Light Rail Vehicle Loads +OCS Loads (Case 1)**



<b>I-90 Homer Hadley Floating Bridge – LRT Impacts</b>		<b>SC Solutions</b>
Subject/Description: <b>OCS Pole Load Analysis</b>	Originator: H.J. Lee	Date: 8/6/08
	Checked: Hassan Sedarat	Date: 8/6/08
Disclaimer: The analysis in this technical document is preliminary and is strictly to be used as advice in determining the feasibility of placing the LRT on the Homer Hadley Floating Bridge and approach spans. It is not intended for any other purpose or as the basis for any final design or construction issue associated with this project.	Calculation No.:TM-01	
	Rev No.: 0	Sheet 30 of 40

**Figure 3-9: Principal Tensile Stress Variation in the x-direction at Deck Section 1 - Self Weight +Post Tension Forces +Light Rail Vehicle Loads +OCS Loads (Case 1)**



**Figure 3-10: Principal Tensile Stress Variation in the x-direction at Deck Section 2 - Self Weight +Post Tension Forces +Light Rail Vehicle Loads +OCS Loads (Case 1)**

# I-90 Homer Hadley Floating Bridge – LRT Impacts

SC Solutions

Subject/Description:  
**OCS Pole Load Analysis**

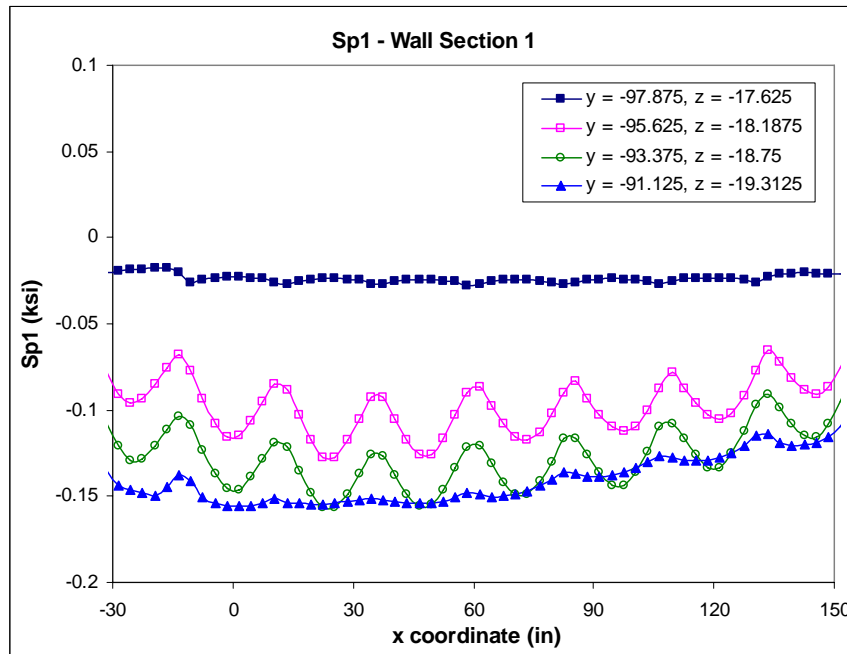
Originator: H.J. Lee      Date: 8/6/08

Checked: Hassan          Date: 8/6/08  
 Sedarat

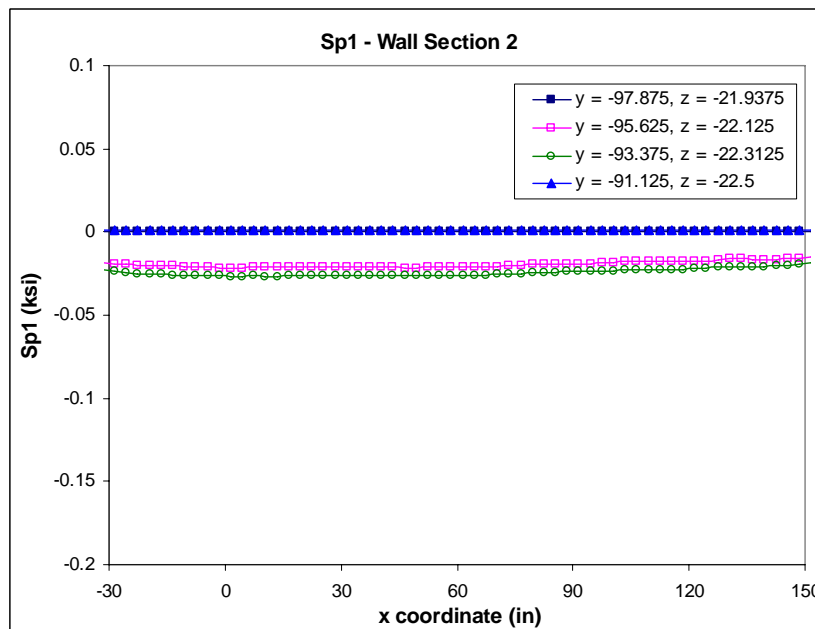
Disclaimer: The analysis in this technical document is preliminary and is strictly to be used as advice in determining the feasibility of placing the LRT on the Homer Hadley Floating Bridge and approach spans. It is not intended for any other purpose or as the basis for any final design or construction issue associated with this project.

Calculation No.:TM-01

Rev No.: **0**                      Sheet 31 of 40



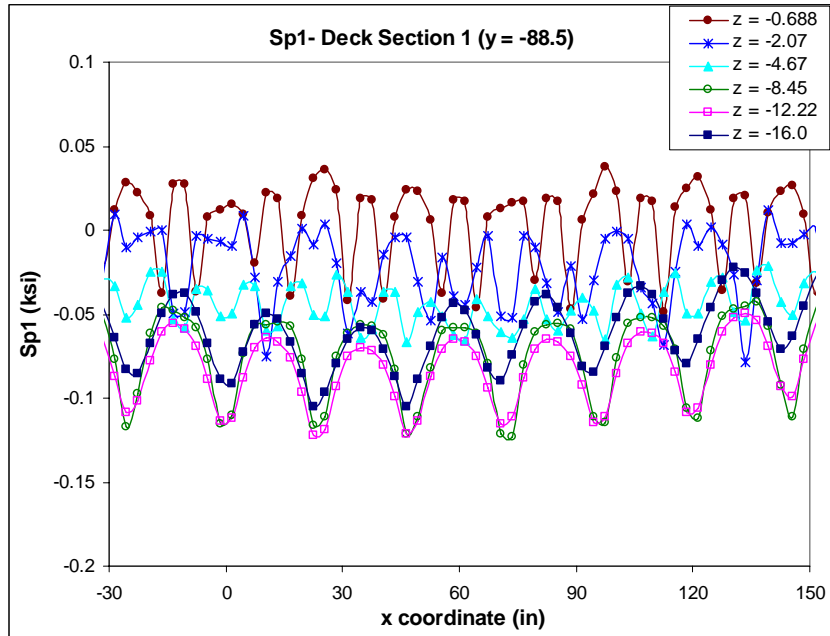
**Figure 3-11: Principal Tensile Stress (Sp1) Variation in the x-direction at Wall Section 1 - Self Weight + Post Tension Forces + Light Rail Vehicle Loads (Case 2)**





<b>I-90 Homer Hadley Floating Bridge – LRT Impacts</b>		<b>SC Solutions</b>
Subject/Description: <b>OCS Pole Load Analysis</b>	Originator: H.J. Lee	Date: 8/6/08
	Checked: Hassan Sedarat	Date: 8/6/08
Disclaimer: The analysis in this technical document is preliminary and is strictly to be used as advice in determining the feasibility of placing the LRT on the Homer Hadley Floating Bridge and approach spans. It is not intended for any other purpose or as the basis for any final design or construction issue associated with this project.	Calculation No.:TM-01	
	Rev No.: <b>0</b>	Sheet 32 of 40

**Figure 3-12: Principal Tensile Stress (Sp1) Variation in the x-direction at Wall Section 2 - Self Weight + Post Tension Forces + Light Rail Vehicle Loads (Case 2)**



**Figure 3-13: Principal Tensile Stress (Sp1) Variation in the x-direction at Deck Section 1 - Self Weight + Post Tension Forces + Light Rail Vehicle Loads (Case 2)**

# I-90 Homer Hadley Floating Bridge – LRT Impacts

SC Solutions

Subject/Description:  
**OCS Pole Load Analysis**

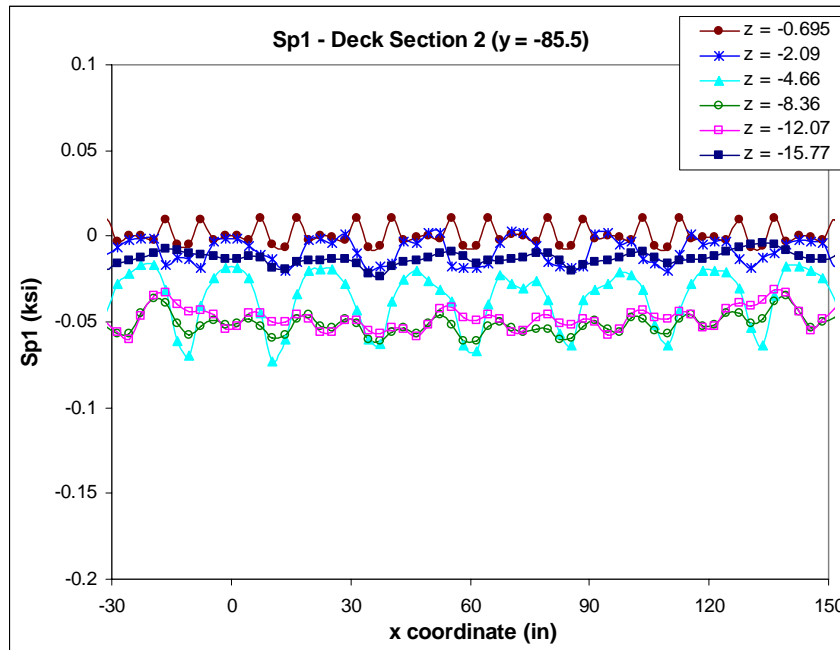
Originator: H.J. Lee      Date: 8/6/08

Checked: Hassan          Date: 8/6/08  
 Sedarat

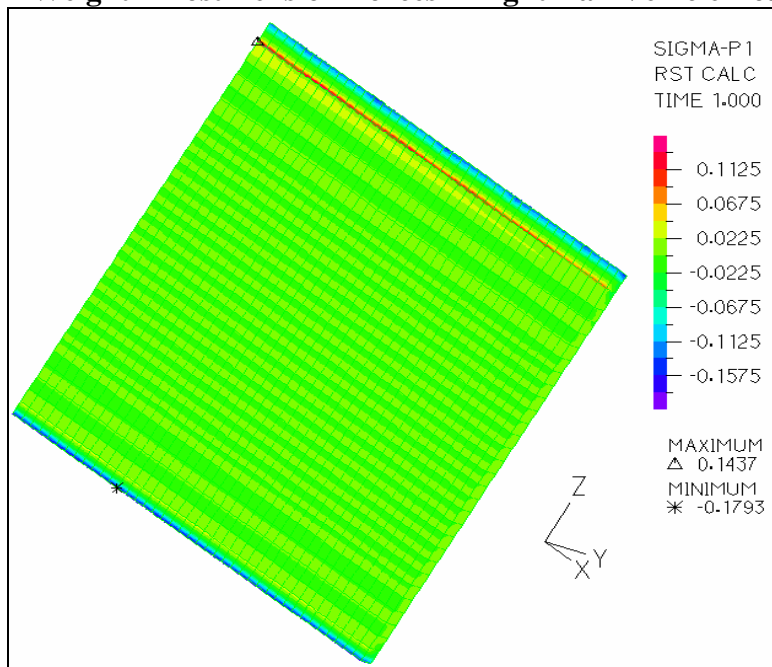
Disclaimer: The analysis in this technical document is preliminary and is strictly to be used as advice in determining the feasibility of placing the LRT on the Homer Hadley Floating Bridge and approach spans. It is not intended for any other purpose or as the basis for any final design or construction issue associated with this project.

Calculation No.:TM-01

Rev No.: **0**                      Sheet 33 of 40

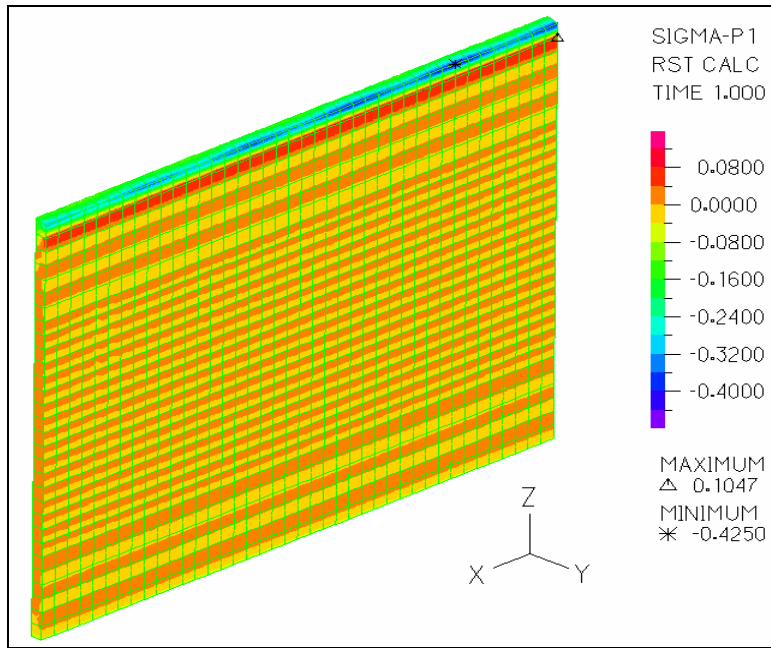


**Figure 3-14: Principal Tensile Stress (Sp1) Variation in the x-direction at Deck Section 2 - Self Weight + Post Tension Forces + Light Rail Vehicle Loads (Case 2)**



<b>I-90 Homer Hadley Floating Bridge – LRT Impacts</b>		<b>SC Solutions</b>
<b>Subject/Description:</b> <b>OCS Pole Load Analysis</b>	Originator: H.J. Lee	Date: 8/6/08
	Checked: Hassan Sedarat	Date: 8/6/08
Disclaimer: The analysis in this technical document is preliminary and is strictly to be used as advice in determining the feasibility of placing the LRT on the Homer Hadley Floating Bridge and approach spans. It is not intended for any other purpose or as the basis for any final design or construction issue associated with this project.	Calculation No.:TM-01	
	Rev No.: 0	Sheet 34 of 40

**Figure 3-15: Principal Tensile Stress Contour Plot at the Inner Surface of the Wall – Self Weight +Post Tension Forces +Light Rail Vehicle Loads +OCS Loads (Case 1)**



**Figure 3-16: Principal Tensile Stress Contour Plot at the Outer Surface of the Wall – Self Weight +Post Tension Forces +Light Rail Vehicle Loads+OCS Loads (Case 1)**

Subject/Description:  
**OCS Pole Load Analysis**

Originator: H.J. Lee  
 Checked: Hassan Sedarat

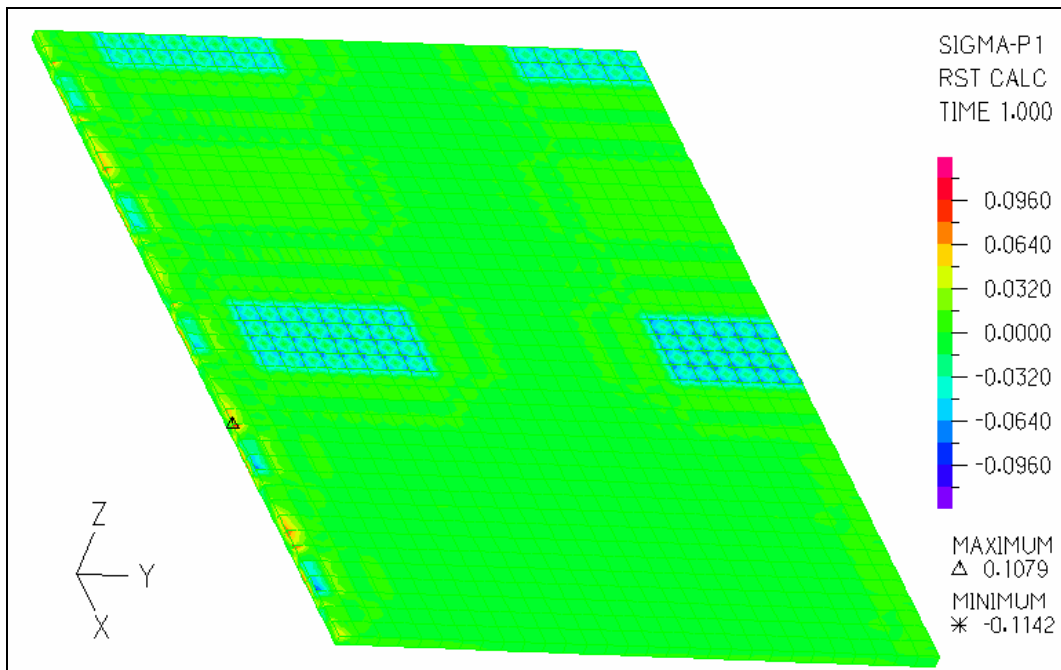
Date: 8/6/08  
 Date: 8/6/08

Disclaimer: The analysis in this technical document is preliminary and is strictly to be used as advice in determining the feasibility of placing the LRT on the Homer Hadley Floating Bridge and approach spans. It is not intended for any other purpose or as the basis for any final design or construction issue associated with this project.

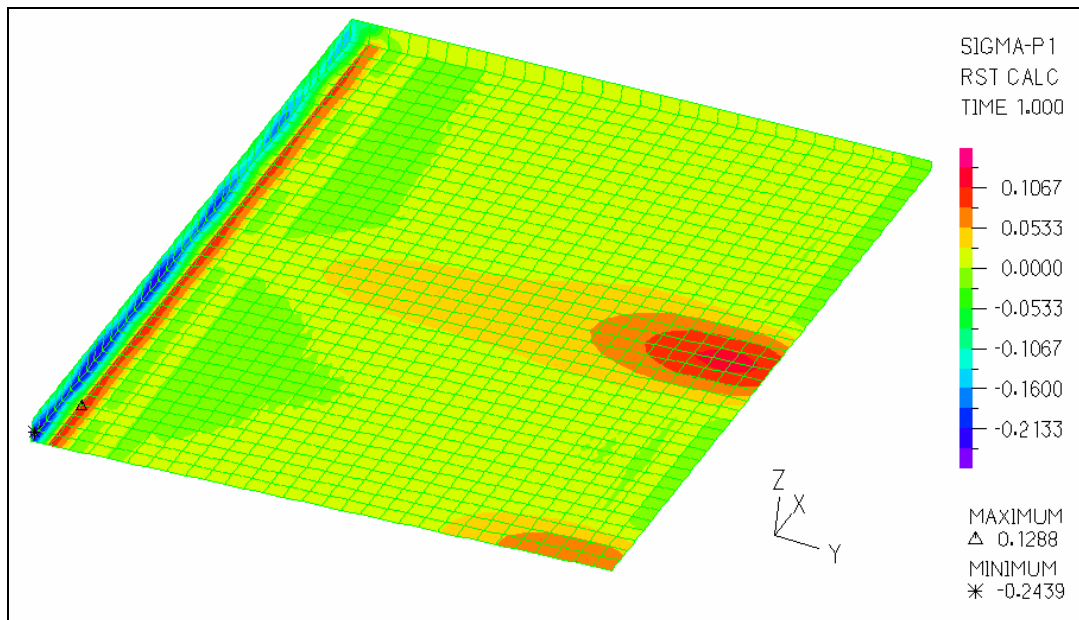
Calculation No.:TM-01

Rev No.: 0

Sheet 35 of 40

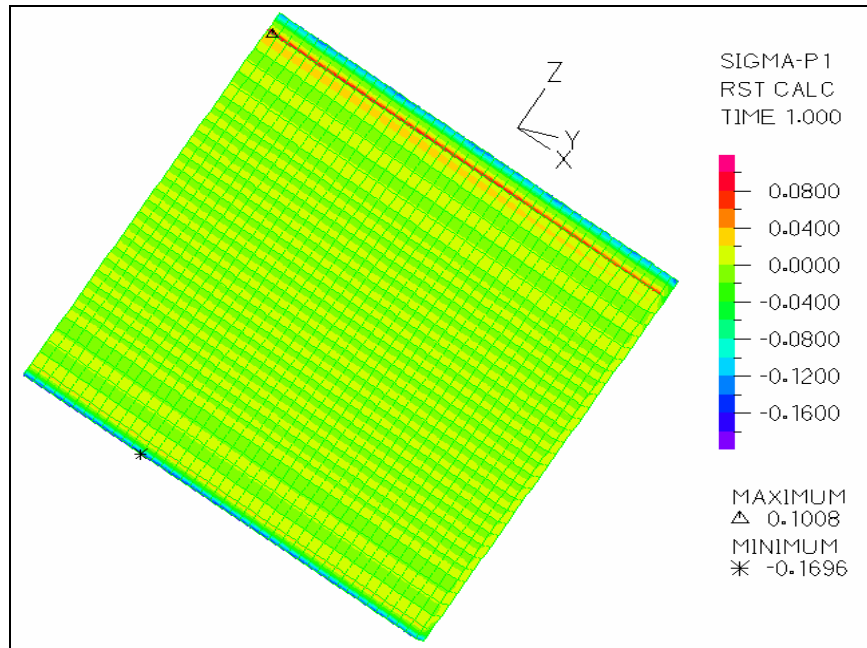


**Figure 3-17: Principal Tensile Stress Contour Plot at the Top Surface of the Deck – Self Weight + Post Tension Forces + Light Rail Vehicle Loads +OCS Loads (Case 1)**



<b>I-90 Homer Hadley Floating Bridge – LRT Impacts</b>		<b>SC Solutions</b>
<b>Subject/Description:</b> <b>OCS Pole Load Analysis</b>	Originator: H.J. Lee	Date: 8/6/08
	Checked: Hassan Sedarat	Date: 8/6/08
Disclaimer: The analysis in this technical document is preliminary and is strictly to be used as advice in determining the feasibility of placing the LRT on the Homer Hadley Floating Bridge and approach spans. It is not intended for any other purpose or as the basis for any final design or construction issue associated with this project.	Calculation No.:TM-01	
	Rev No.: 0	Sheet 36 of 40

**Figure 3-18: Principal Tensile Stress Contour Plot at the Bottom Surface of the Deck – Self Weight +Post Tension Forces +Light Rail Vehicle Loads +OCS Loads (Case 1)**



**Figure 3-19: Principal Tensile Stress (Sp1) Contour Plot at the Inner Surface of the Wall – Self Weight + Post Tension Forces + Light Rail Vehicle Loads (Case 2)**

Subject/Description:  
**OCS Pole Load Analysis**

Originator: H.J. Lee  
 Checked: Hassan Sedarat

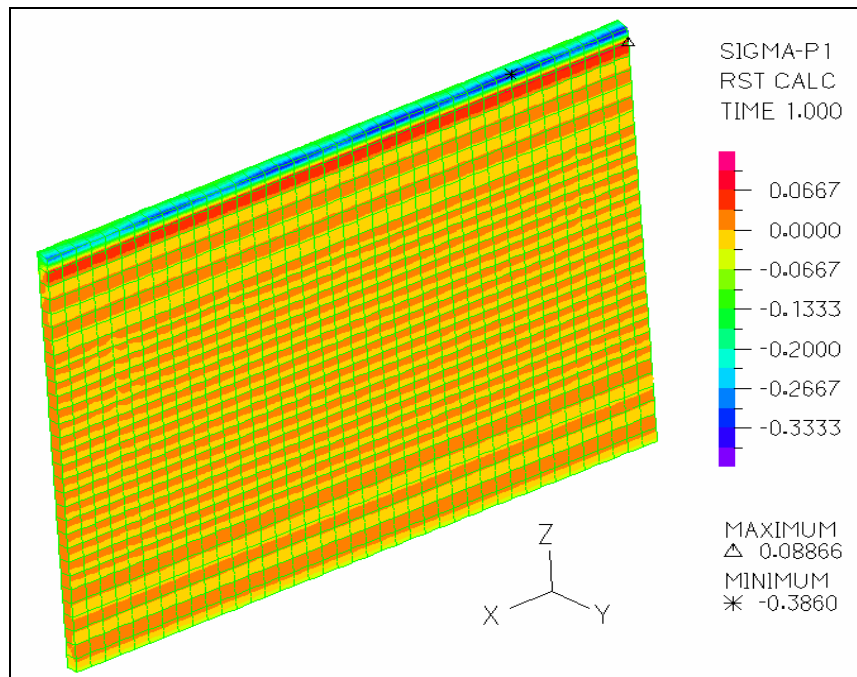
Date: 8/6/08  
 Date: 8/6/08

Disclaimer: The analysis in this technical document is preliminary and is strictly to be used as advice in determining the feasibility of placing the LRT on the Homer Hadley Floating Bridge and approach spans. It is not intended for any other purpose or as the basis for any final design or construction issue associated with this project.

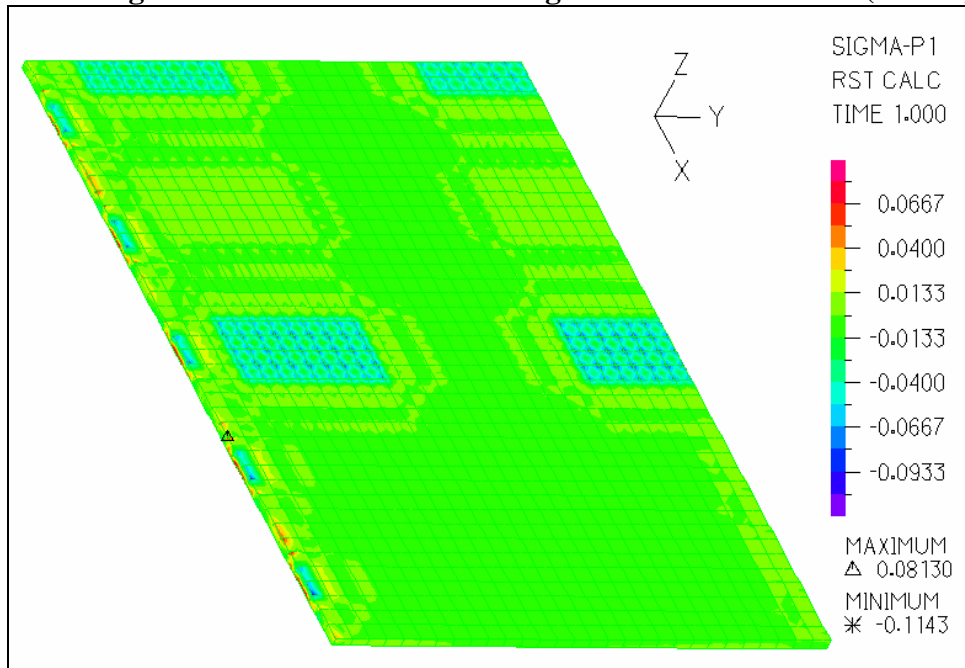
Calculation No.:TM-01

Rev No.: 0

Sheet 37 of 40

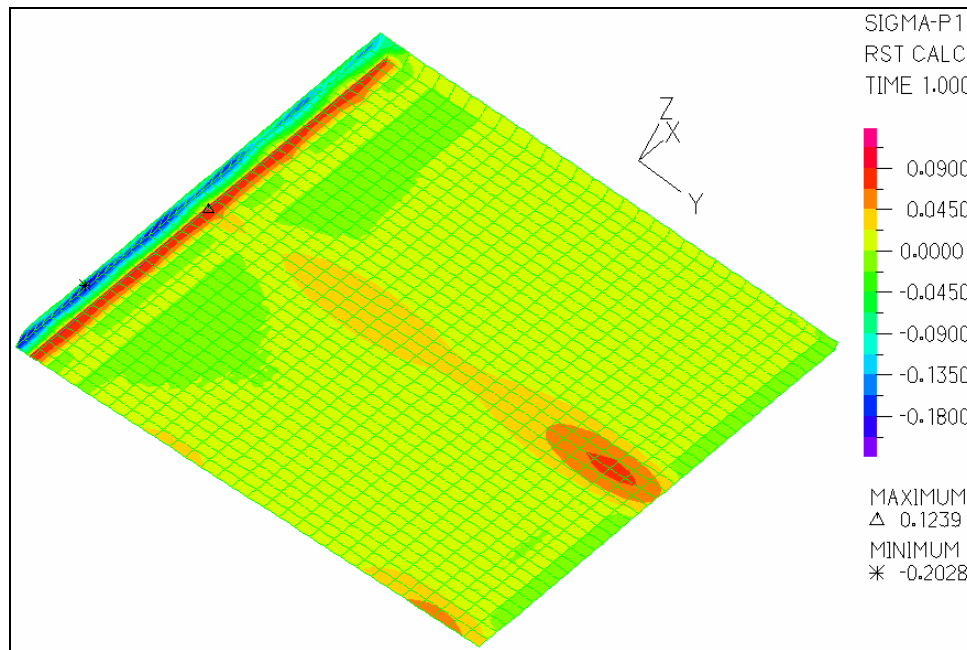


**Figure 3-20: Principal Tensile Stress (Sp1) Contour Plot at the Outer Surface of the Wall – Self Weight + Post Tension Forces + Light Rail Vehicle Loads (Case 2)**



I-90 Homer Hadley Floating Bridge – LRT Impacts		SC Solutions
Subject/Description: <b>OCS Pole Load Analysis</b>	Originator: H.J. Lee	Date: 8/6/08
	Checked: Hassan Sedarat	Date: 8/6/08
Disclaimer: The analysis in this technical document is preliminary and is strictly to be used as advice in determining the feasibility of placing the LRT on the Homer Hadley Floating Bridge and approach spans. It is not intended for any other purpose or as the basis for any final design or construction issue associated with this project.	Calculation No.:TM-01	
	Rev No.: 0	Sheet 38 of 40

**Figure 3-21: Principal Tensile Stress (Sp1) Contour Plot at the Top Surface of the Deck – Self Weight + Post Tension Forces + Light Rail Vehicle Loads (Case 2)**



**Figure 3-22: Principal Tensile Stress (Sp1) Contour Plot at the Bottom Surface of the Deck – Self Weight + Post Tension Forces + Light Rail Vehicle Loads (Case 2)**

## 4. Conclusion

### 4.1 Conclusion based on OCS Model Analysis Results

It seems that maximum principal tensile stress is not a significant concern under combined self weight, post-tensioning forces and OCS loads. It is likely that the principal tensile stresses at the roadway surface of the deck are zero or very little values. The analysis results of this study are based on the unfactored loads. To apply a load factor of 1.3 is not going to change the conclusion because stress magnitude is small.

<b>I-90 Homer Hadley Floating Bridge – LRT Impacts</b>		<b>SC Solutions</b>
<b>Subject/Description:</b> <b>OCS Pole Load Analysis</b>	Originator: H.J. Lee	Date: 8/6/08
	Checked: Hassan Sedarat	Date: 8/6/08
Disclaimer: The analysis in this technical document is preliminary and is strictly to be used as advice in determining the feasibility of placing the LRT on the Homer Hadley Floating Bridge and approach spans. It is not intended for any other purpose or as the basis for any final design or construction issue associated with this project.	Calculation No.:TM-01	
	Rev No.: 0	Sheet 39 of 40

## 4.2 Conclusion based on Cantilever Model Analysis Results

Normal stresses at the critical sections of the wall and the deck are in compression for both the cases with and without OCS pole loads. The maximum principal tensile stress value at the inner and outer surfaces of the wall is slightly larger than a design stress limit of 141 psi in a certain case (demand/capacity ratio=1.016), but does not exceed a stress limit of 168 psi based on concrete strength test results. Maximum principal tensile stress values at the top and bottom surfaces of the deck are less than a design stress limit except local zones related to the vertical post-tension bars.

## 5. References

1. Parsons and INCA Technical Memorandum (May, 2008 – Sound Transit East Link Project – OCS Pole/Deck Attachment Analysis)
2. ADINA version 8.3



<b>I-90 Homer Hadley Floating Bridge – LRT Impacts</b>		<b>SC Solutions</b>
<b>Subject/Description:</b> <b>OCS Pole Load Analysis</b>	Originator: H.J. Lee	Date: 8/6/08
	Checked: Hassan Sedarat	Date: 8/6/08
Disclaimer: The analysis in this technical document is preliminary and is strictly to be used as advice in determining the feasibility of placing the LRT on the Homer Hadley Floating Bridge and approach spans. It is not intended for any other purpose or as the basis for any final design or construction issue associated with this project.	Calculation No.:TM-01	
	Rev No.: <b>0</b>	Sheet 40 of 40

3. Drawings: As built drawings
4. INCA Technical Memorandum (May, 2008 – Sound Transit East Link Project – Plinth Block Analysis)
5. INCA OCS Pole Attachment Calculations
6. CH2M HILL and Mayes Technical Memorandum (May 7, 2008 – Sound Transit East Link Project – IRT Issue – Homer Hadley Floating Bridge Core Drilled Concrete Specimens)

**I-90 Homer Hadley Floating Bridge – LRT Impacts  
TECHNICAL MEMORANDUM COVER SHEET**

**Technical Memorandum TM-02  
Torsional Analysis**

**Prepared by: SC Solutions  
Date: August 6, 2008**

**Disclaimer:**

The analysis in this technical document is preliminary and is strictly to be used as advice in determining the feasibility of placing the LRT on the Homer Hadley Floating Bridge and approach spans. It is not intended for any other purpose or as the basis for any final design or construction issue associated with this project.

<b>I-90 Homer Hadley Floating Bridge – LRT Impacts</b>		<b>SC Solutions</b>
<b>Subject/Description:</b> <b>Torsional Analysis</b>	Originator: H.J. Lee	Date: 8/6/08
	Checked: Hassan Sedarat	Date: 8/6/08
Disclaimer: The analysis in this technical document is preliminary and is strictly to be used as advice in determining the feasibility of placing the LRT on the Homer Hadley Floating Bridge and approach spans. It is not intended for any other purpose or as the basis for any final design or construction issue associated with this project.	Calculation No.:TM-02	
	Rev No.: <b>0</b>	Sheet 2 of 23

### Table of Contents

<b>1. Introduction .....</b>	<b>3</b>
1.1 Problem Statement .....	3
1.2 Objective .....	3
<b>2. Basis for Analysis.....</b>	<b>4</b>
2.1 Model Development.....	4
2.2 Load and Boundary Conditions .....	4
2.3 Material Properties.....	5
<b>3. Discussion.....</b>	<b>7</b>
3.1 Comparison of a Finite Element Analysis Result with a Hand Calculation .....	7
3.2 Stress Contour Plots at Critical Sections of the Pontoon Deck and Wall.....	7
<b>4. Conclusion .....</b>	<b>20</b>
<b>5. References .....</b>	<b>23</b>

<b>I-90 Homer Hadley Floating Bridge – LRT Impacts</b>		<b>SC Solutions</b>
<b>Subject/Description:</b> <b>Torsional Analysis</b>	Originator: H.J. Lee	Date: 8/6/08
	Checked: Hassan Sedarat	Date: 8/6/08
Disclaimer: The analysis in this technical document is preliminary and is strictly to be used as advice in determining the feasibility of placing the LRT on the Homer Hadley Floating Bridge and approach spans. It is not intended for any other purpose or as the basis for any final design or construction issue associated with this project.	Calculation No.:TM-02	
	Rev No.: 0	Sheet 3 of 23

## 1. Introduction

### 1.1 Problem Statement

According to the report by KPFF [1], the pontoons of the I-90 Homer Hadley Bridge are subjected to large torsional moment resulting from light rail transit (LRT) load, traffic load, and storm load. There was a concern about the corrosive environment at the deck and wall surfaces. Thus, it needs to be confirmed that tensile stress should be less than the value specified in the design criteria under torsional loads. For this purpose, it was necessary to perform a detailed three-dimensional finite element analysis for the better estimation of principal tensile stress. In this study, a full section model using ADINA [2] 20-node three-dimensional solid elements was analyzed under a sea state condition of a one-year north storm. Based on finite element analysis results and test results on concrete strength by Mayes Testing Engineers [3], a torsional moment capacity of a full section was predicted. This predicted torsional capacity was compared with the torsional demand reported by KPFF [1].

### 1.2 Objective

The objective of a full section model analysis is to obtain the demand/capacity ratio of a full section subjected to torsion. A torsion of 6202 kip-ft for a one-year north storm was used for analysis. From a three-dimensional solid finite element analysis using ADINA, a maximum principal tensile stress value at the critical locations of the pontoon wall and deck was obtained. Based on the maximum principal tensile stress value and design acceptance criteria, a torsional moment capacity of a full section was obtained. The obtained torsional moment capacity of a full section was compared with the maximum torsional moment demand presented in the KPFF report [1]. It was confirmed that the torsional moment demand/capacity ratio is less than 1.0, which means that the bridge is good for torsional load.

I-90 Homer Hadley Floating Bridge – LRT Impacts		SC Solutions
Subject/Description: <b>Torsional Analysis</b>	Originator: H.J. Lee	Date: 8/6/08
	Checked: Hassan Sedarat	Date: 8/6/08
Disclaimer: The analysis in this technical document is preliminary and is strictly to be used as advice in determining the feasibility of placing the LRT on the Homer Hadley Floating Bridge and approach spans. It is not intended for any other purpose or as the basis for any final design or construction issue associated with this project.	Calculation No.:TM-02	
	Rev No.: 0	Sheet 4 of 23

## 2. Basis for Analysis

### 2.1 Model Development

A full section model was analyzed to investigate stresses at the critical regions under a sea state condition of a one-year north storm. A detailed three-dimensional finite element model of a full section using 20-node solid elements was built based on the project as-built drawings [4]. The substructure model boundary of the full section model is shown in **Figure 2-1**. The full section model analyzed a portion of Pontoon J and a longitudinal length of 235 ft was modeled in the full section analysis. A fine mesh was used in the middle regions of the full section model because stresses were investigated in these middle zones to remove boundary effects. A coarse mesh was used in the regions close to the longitudinal ends because these regions were included to consider boundary effects related to loading and restraint conditions.

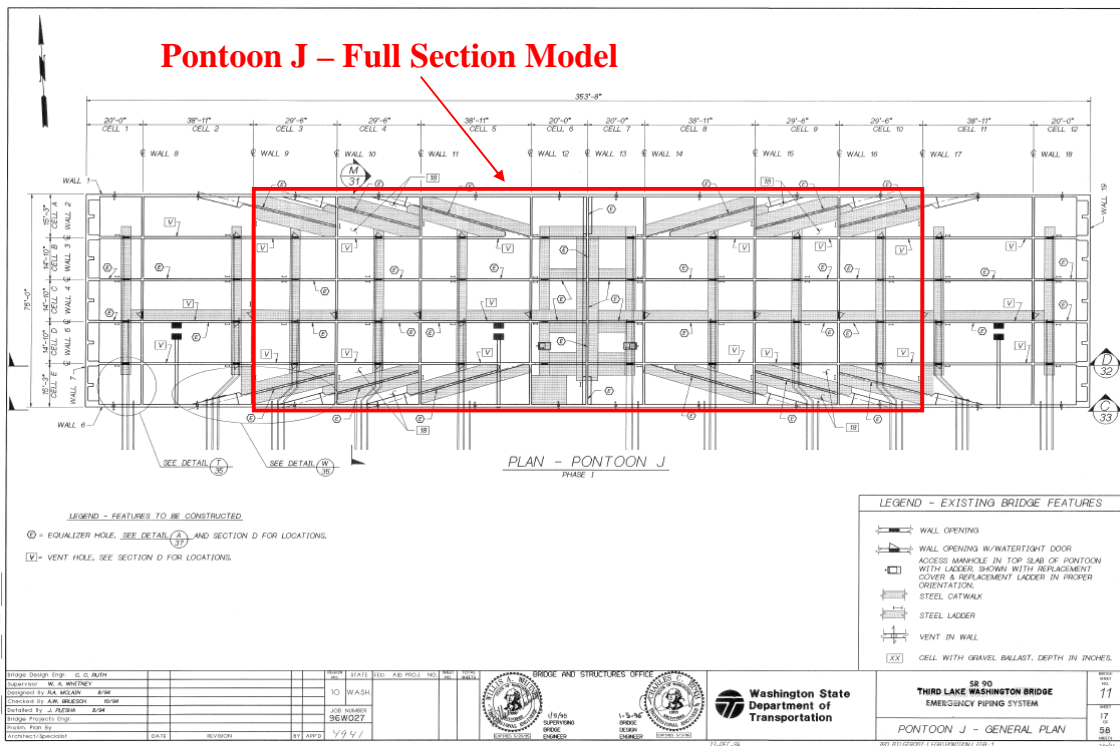
### 2.2 Load and Boundary Conditions

Load and boundary conditions of the full section model is shown in **Figure 2-2**. One longitudinal end of the substructure model was fixed against all translations. A torsion of 6202 kip-ft for a one-year north storm was applied to the other longitudinal end of the substructure model. The torsion was applied to a master node at the centroid of the longitudinal end section. The other nodes of the section were connected to the master node by rigid links. The full section model did not include any post-tension bars and was subjected to pure torsion. Therefore, the full section model focuses on the effects of torsion.

<b>I-90 Homer Hadley Floating Bridge – LRT Impacts</b>		<b>SC Solutions</b>
<b>Subject/Description:</b> <b>Torsional Analysis</b>	Originator: H.J. Lee	Date: 8/6/08
	Checked: Hassan Sedarat	Date: 8/6/08
Disclaimer: The analysis in this technical document is preliminary and is strictly to be used as advice in determining the feasibility of placing the LRT on the Homer Hadley Floating Bridge and approach spans. It is not intended for any other purpose or as the basis for any final design or construction issue associated with this project.	Calculation No.:TM-02	
	Rev No.: 0	Sheet 5 of 23

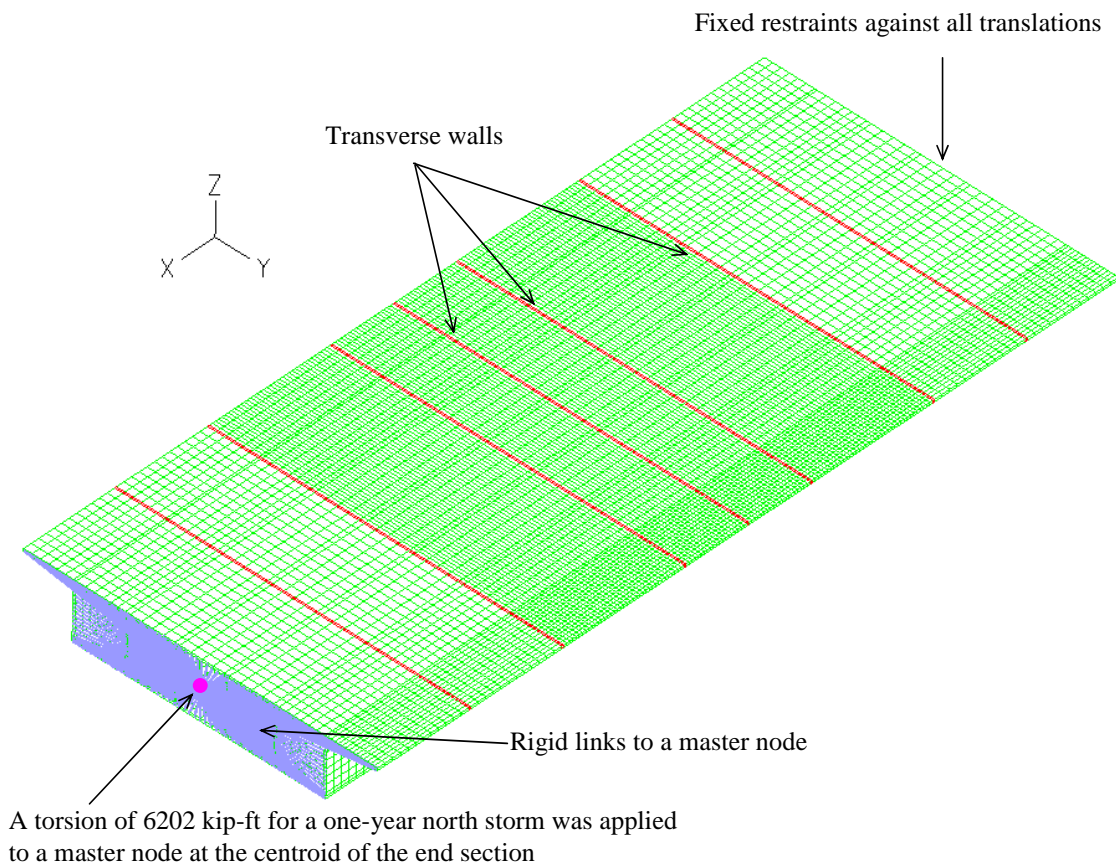
### 2.3 Material Properties

Since a linear elastic analysis was performed, Young’s modulus ( $E$ ) = 4030.5 ksi and Poisson’s ratio ( $\nu$ ) = 0.15 of concrete were necessary for material property input data. Since the same concrete material properties were used for all concrete elements, a change in the Young’s modulus value does not affect stress magnitude values.



**Figure 2-1: Substructure Model Boundary of a Full Section Model**

<b>I-90 Homer Hadley Floating Bridge – LRT Impacts</b>		<b>SC Solutions</b>
<b>Subject/Description:</b> <b>Torsional Analysis</b>	Originator: H.J. Lee	Date: 8/6/08
	Checked: Hassan Sedarat	Date: 8/6/08
Disclaimer: The analysis in this technical document is preliminary and is strictly to be used as advice in determining the feasibility of placing the LRT on the Homer Hadley Floating Bridge and approach spans. It is not intended for any other purpose or as the basis for any final design or construction issue associated with this project.	Calculation No.:TM-02	
	Rev No.: 0	Sheet 6 of 23



**Figure 2-2: Loading and Boundary Conditions of a Full Section Model**

I-90 Homer Hadley Floating Bridge – LRT Impacts		SC Solutions
Subject/Description: <b>Torsional Analysis</b>	Originator: H.J. Lee	Date: 8/6/08
	Checked: Hassan Sedarat	Date: 8/6/08
Disclaimer: The analysis in this technical document is preliminary and is strictly to be used as advice in determining the feasibility of placing the LRT on the Homer Hadley Floating Bridge and approach spans. It is not intended for any other purpose or as the basis for any final design or construction issue associated with this project.	Calculation No.:TM-02	
	Rev No.: 0	Sheet 7 of 23

### 3. Discussion

#### 3.1 Comparison of a Finite Element Analysis Result with a Hand Calculation

A deformed shape of the full section model under a pure torsion of 6202 kip-ft is shown in **Figure 3-1**. ADINA predicted a twist angle of 1.7136E-4 in this case. A hand calculation was also performed to check this analysis result. The hand calculation was based on a thin-walled rectangular tube assumption of the pontoon full section shown in **Figure 3-2** and used the following formula:

$$\text{Twist angle } (\phi) = \frac{TL}{GJ} = \frac{74424 \times 2824}{1920 \times 5.4309E8} = 2.0156E-4$$

where T = a torsion value = 6202 kip-ft = 74424 kip-inch.

L = a longitudinal length of the full section model = 235 ft = 2824 inch.

G = a shear modulus = 1920 ksi

$$J = \text{a torsional constant} = \frac{2b^2h^2t_1t_2}{bt_1+ht_2} = 5.4309E8$$

A prediction by a hand calculation was 2.0156E-4 and was slightly larger than that by ADINA because the stiffness contribution of the inner walls and cantilever parts of the pontoon section was neglected in the hand calculation. Thus, the ADINA result seems to be reasonable.

#### 3.2 Stress Contour Plots at Critical Sections of the Pontoon Deck and Wall

A principal tensile stress (Sp1) contour plot is shown in **Figure 3-3**. The overall stress values are small and stress values at some local locations near the longitudinal ends are larger than those in the middle zone because of boundary effects. The stress contour plots at the critical zones shown in **Figure 3-4** and **Figure 3-5** were generated. Principal tensile stress (Sp1) contour plots at the deck element zone 1 are shown in **Figure 3-6**. The maximum principal tensile stress value is 14 psi. Transverse normal stress (Syy) contour plots at the deck element zone 1 are shown in **Figure 3-7**. The maximum transverse normal stress value at the deck element zone 1 is close to zero.



I-90 Homer Hadley Floating Bridge – LRT Impacts		SC Solutions
Subject/Description: <b>Torsional Analysis</b>	Originator: H.J. Lee	Date: 8/6/08
	Checked: Hassan Sedarat	Date: 8/6/08
Disclaimer: The analysis in this technical document is preliminary and is strictly to be used as advice in determining the feasibility of placing the LRT on the Homer Hadley Floating Bridge and approach spans. It is not intended for any other purpose or as the basis for any final design or construction issue associated with this project.	Calculation No.:TM-02	
	Rev No.: 0	Sheet 8 of 23

Principal tensile stress ( $S_{p1}$ ) contour plots at the wall element zone 1 are shown in **Figure 3-8**. The maximum principal tensile stress value is 24 psi. Vertical normal stress ( $S_{zz}$ ) contour plots at the wall element zone 1 are shown in **Figure 3-9**. The maximum transverse normal stress value at the wall element zone 1 is close to zero.

Principal tensile stress ( $S_{p1}$ ) contour plots at the wall element zone 2 are shown in **Figure 3-10**. The maximum principal tensile stress value is 22 psi. Vertical normal stress ( $S_{zz}$ ) contour plots at the wall element zone 2 are shown in **Figure 3-11**. The maximum transverse normal stress value at the wall element zone 2 is close to zero. It seems that torsion does not much contribute to normal stress, while principal tensile stress resulting from torsion is not negligible.

# I-90 Homer Hadley Floating Bridge – LRT Impacts

SC Solutions

Subject/Description:  
**Torsional Analysis**

Originator: H.J. Lee

Date: 8/6/08

Checked: Hassan  
Sedarat

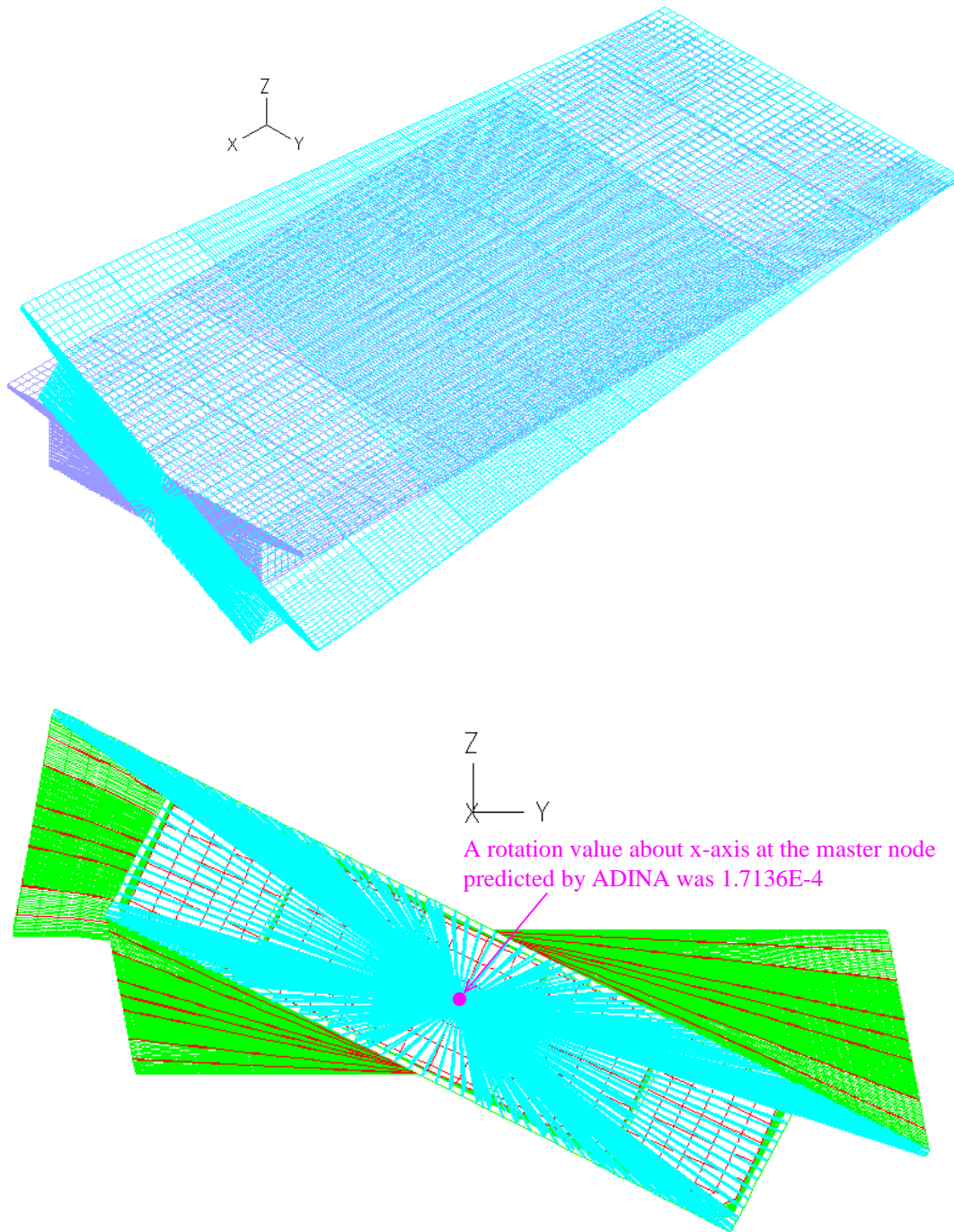
Date: 8/6/08

Disclaimer: The analysis in this technical document is preliminary and is strictly to be used as advice in determining the feasibility of placing the LRT on the Homer Hadley Floating Bridge and approach spans. It is not intended for any other purpose or as the basis for any final design or construction issue associated with this project.

Calculation No.:TM-02

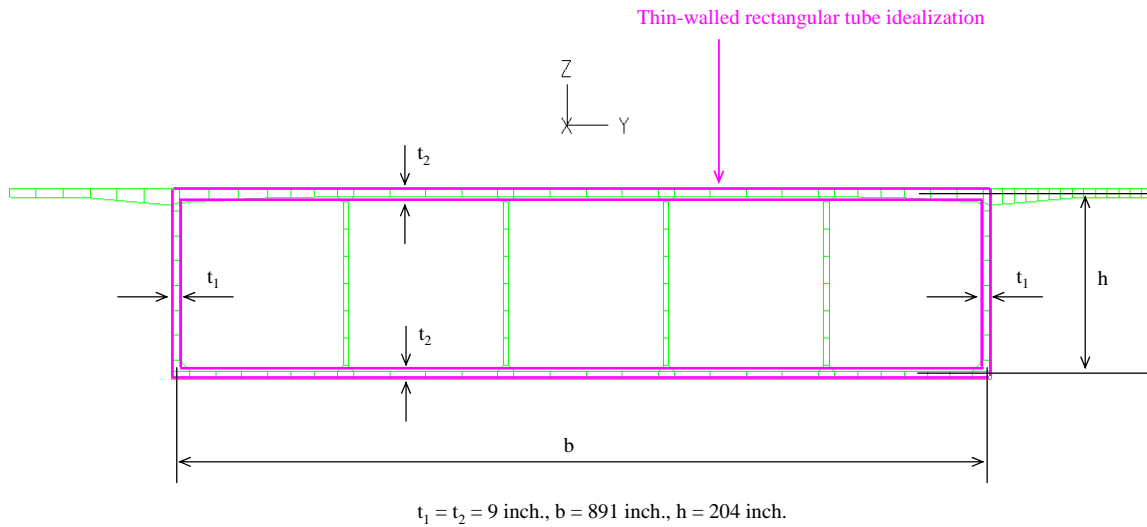
Rev No.: 0

Sheet 9 of 23



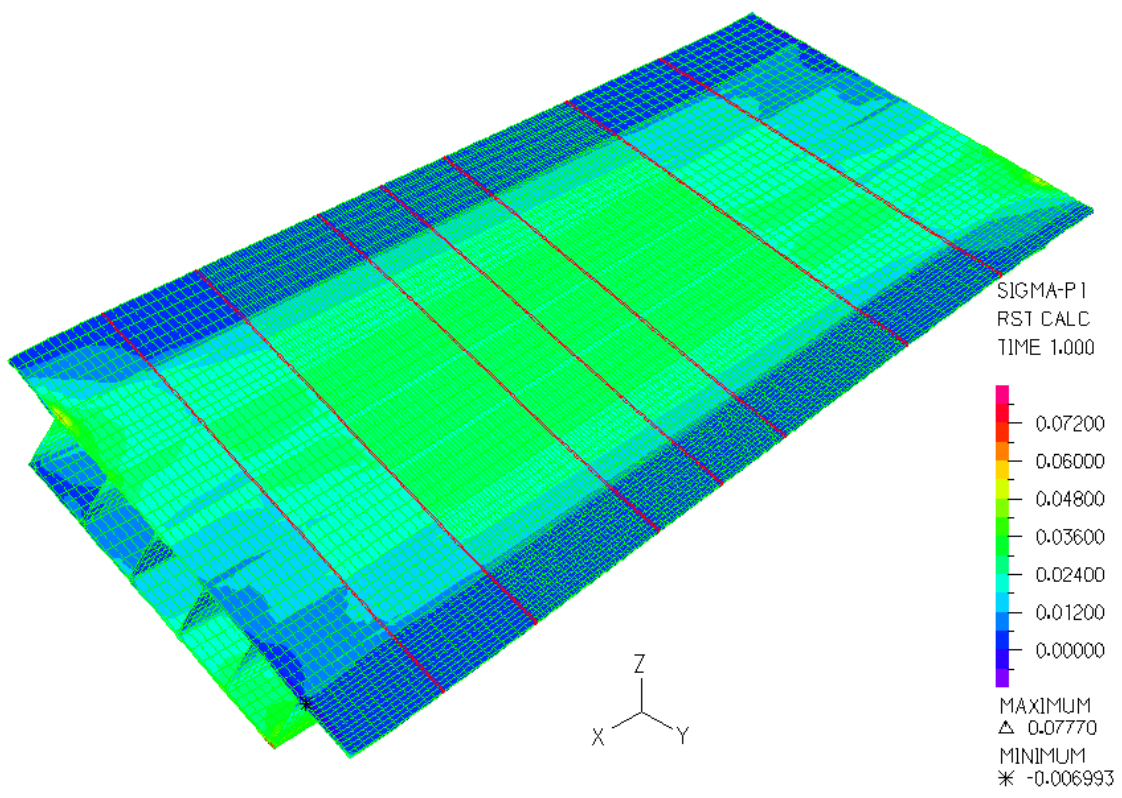
**Figure 3-1: Deformed Shape of a Full Section Model under a Torsion of 6202 kip-ft**

<b>I-90 Homer Hadley Floating Bridge – LRT Impacts</b>		<b>SC Solutions</b>
<b>Subject/Description:</b> <b>Torsional Analysis</b>	Originator: H.J. Lee	Date: 8/6/08
	Checked: Hassan Sedarat	Date: 8/6/08
Disclaimer: The analysis in this technical document is preliminary and is strictly to be used as advice in determining the feasibility of placing the LRT on the Homer Hadley Floating Bridge and approach spans. It is not intended for any other purpose or as the basis for any final design or construction issue associated with this project.	Calculation No.:TM-02	
	Rev No.: <b>0</b>	Sheet 10 of 23



**Figure 3-2: Thin-Walled Rectangular Tube Assumption of a Pontoon Full Section for a Twist Angle Prediction**

<b>I-90 Homer Hadley Floating Bridge – LRT Impacts</b>		<b>SC Solutions</b>
<b>Subject/Description:</b> <b>Torsional Analysis</b>	Originator: H.J. Lee	Date: 8/6/08
	Checked: Hassan Sedarat	Date: 8/6/08
Disclaimer: The analysis in this technical document is preliminary and is strictly to be used as advice in determining the feasibility of placing the LRT on the Homer Hadley Floating Bridge and approach spans. It is not intended for any other purpose or as the basis for any final design or construction issue associated with this project.	Calculation No.:TM-02	
	Rev No.: 0	Sheet 11 of 23



**Figure 3-3: Principal Tensile Stress (Sp1) Contour Plot under a Torsion of 6202 kip-ft**

Subject/Description:  
**Torsional Analysis**

Originator: H.J. Lee  
 Checked: Hassan Sedarat

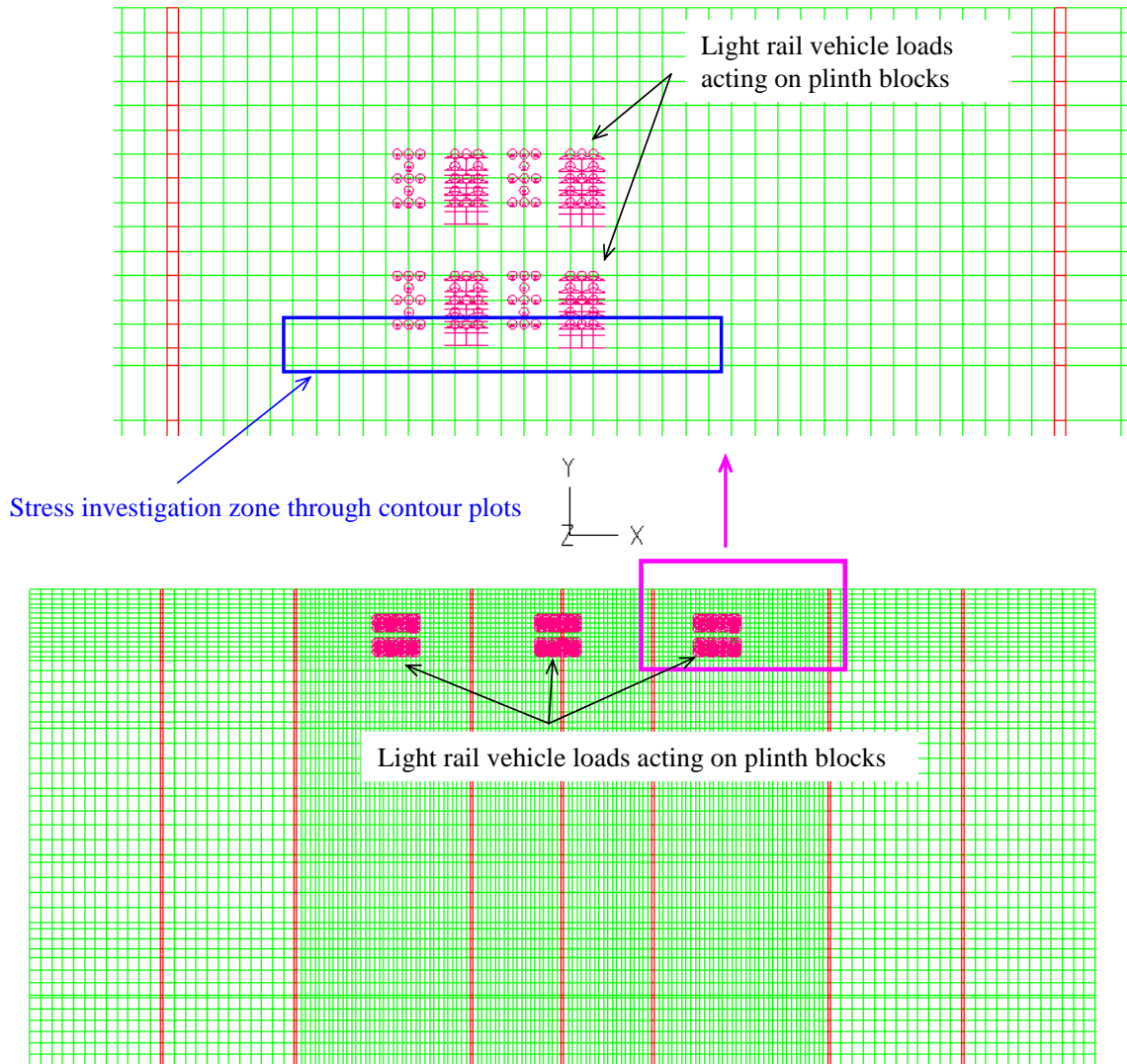
Date: 8/6/08  
 Date: 8/6/08

Disclaimer: The analysis in this technical document is preliminary and is strictly to be used as advice in determining the feasibility of placing the LRT on the Homer Hadley Floating Bridge and approach spans. It is not intended for any other purpose or as the basis for any final design or construction issue associated with this project.

Calculation No.:TM-02

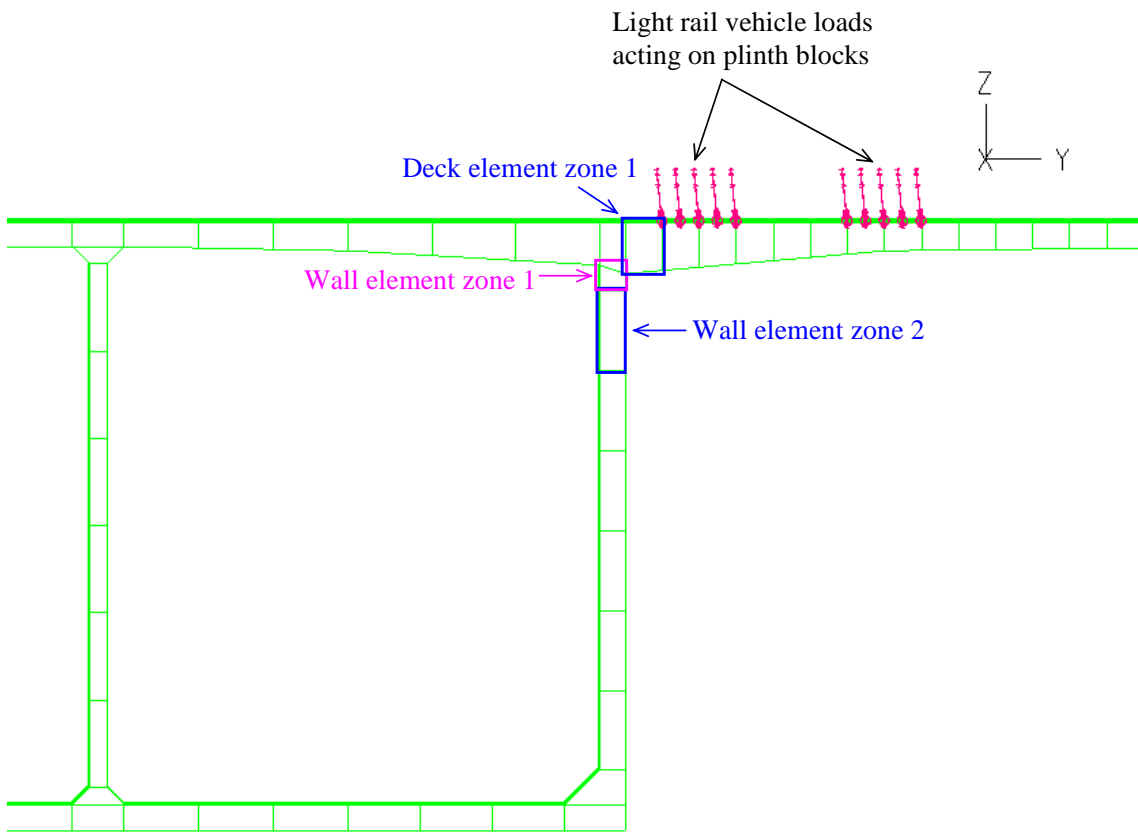
Rev No.: 0

Sheet 12 of 23



**Figure 3-4: Critical Zones selected for Stress Investigation – Plan View**

I-90 Homer Hadley Floating Bridge – LRT Impacts		SC Solutions
Subject/Description: <b>Torsional Analysis</b>	Originator: H.J. Lee	Date: 8/6/08
	Checked: Hassan Sedarat	Date: 8/6/08
Disclaimer: The analysis in this technical document is preliminary and is strictly to be used as advice in determining the feasibility of placing the LRT on the Homer Hadley Floating Bridge and approach spans. It is not intended for any other purpose or as the basis for any final design or construction issue associated with this project.	Calculation No.:TM-02	
	Rev No.: <b>0</b>	Sheet 13 of 23



**Figure 3-5: Critical Zones selected for Stress Investigation – Elevation View**

Subject/Description:  
**Torsional Analysis**

Originator: H.J. Lee  
 Checked: Hassan Sedarat

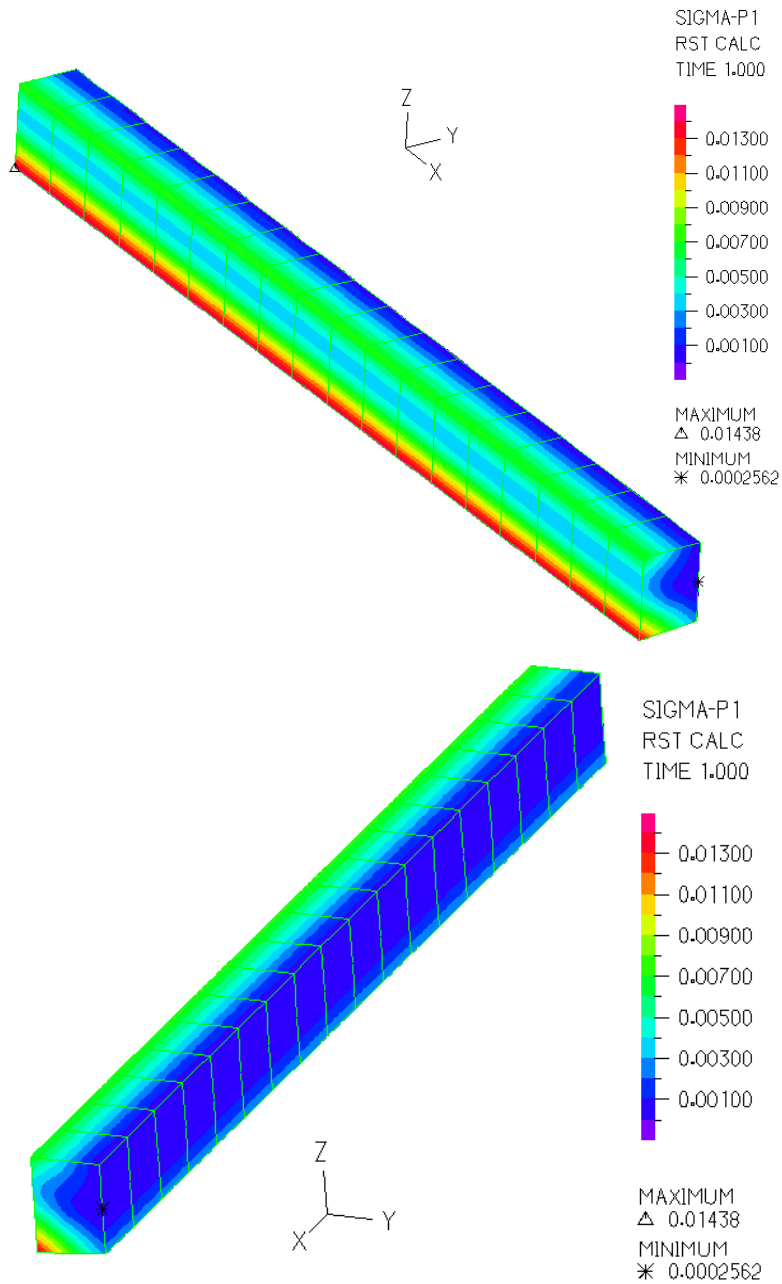
Date: 8/6/08  
 Date: 8/6/08

Disclaimer: The analysis in this technical document is preliminary and is strictly to be used as advice in determining the feasibility of placing the LRT on the Homer Hadley Floating Bridge and approach spans. It is not intended for any other purpose or as the basis for any final design or construction issue associated with this project.

Calculation No.:TM-02

Rev No.: 0

Sheet 14 of 23



**Figure 3-6: Principal Tensile Stress (Sp1) Contour Plots at the Deck Element Zone 1 under a Torsion of 6202 kip-ft**

Subject/Description:  
**Torsional Analysis**

Originator: H.J. Lee  
 Checked: Hassan Sedarat

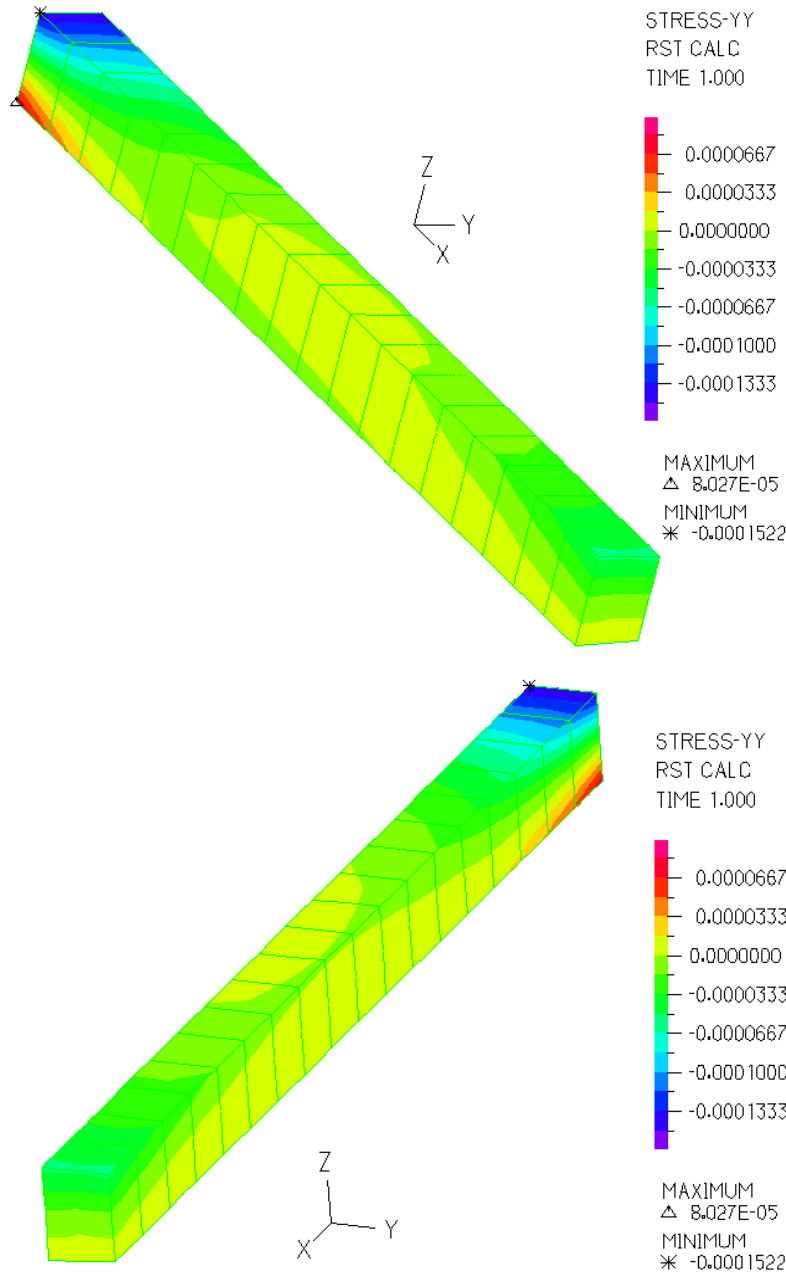
Date: 8/6/08  
 Date: 8/6/08

Disclaimer: The analysis in this technical document is preliminary and is strictly to be used as advice in determining the feasibility of placing the LRT on the Homer Hadley Floating Bridge and approach spans. It is not intended for any other purpose or as the basis for any final design or construction issue associated with this project.

Calculation No.:TM-02

Rev No.: 0

Sheet 15 of 23



**Figure 3-7: Transverse Normal Stress (Syy) Contour Plots at the Deck Element Zone 1 under a Torsion of 6202 kip-ft**



Subject/Description:  
**Torsional Analysis**

Originator: H.J. Lee  
 Checked: Hassan Sedarat

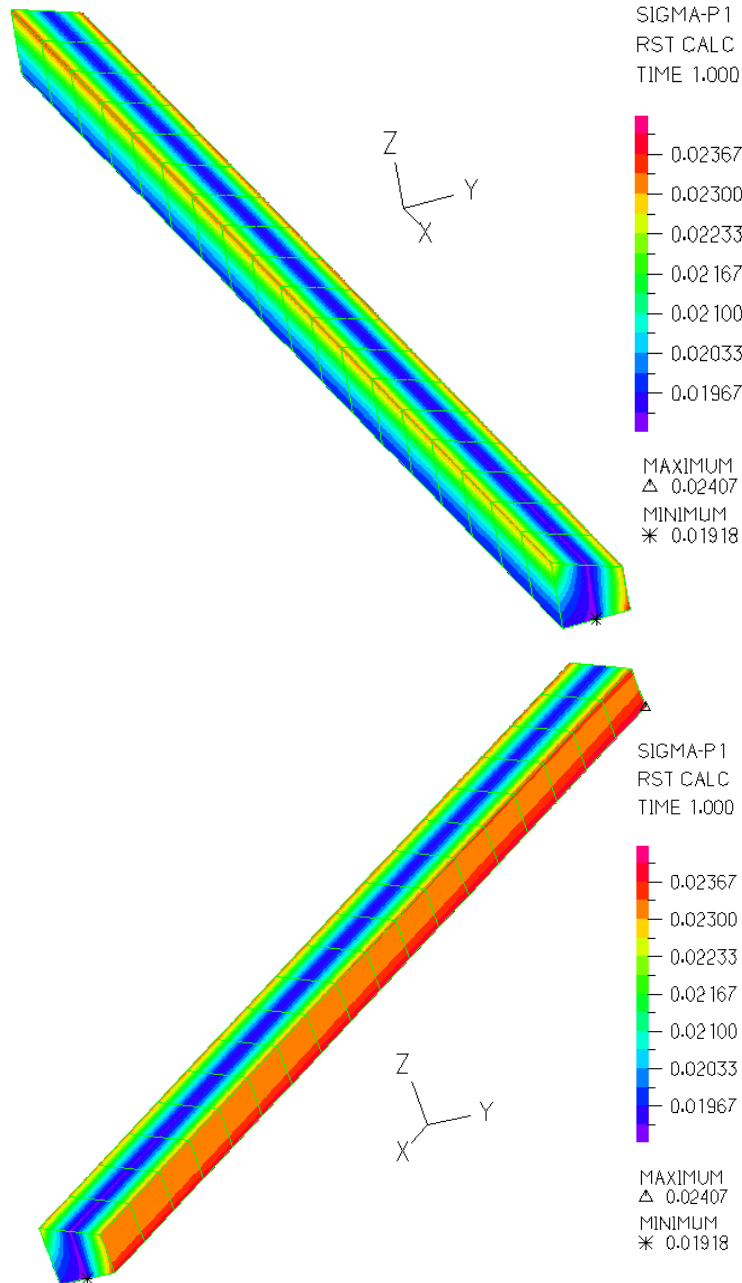
Date: 8/6/08  
 Date: 8/6/08

Disclaimer: The analysis in this technical document is preliminary and is strictly to be used as advice in determining the feasibility of placing the LRT on the Homer Hadley Floating Bridge and approach spans. It is not intended for any other purpose or as the basis for any final design or construction issue associated with this project.

Calculation No.:TM-02

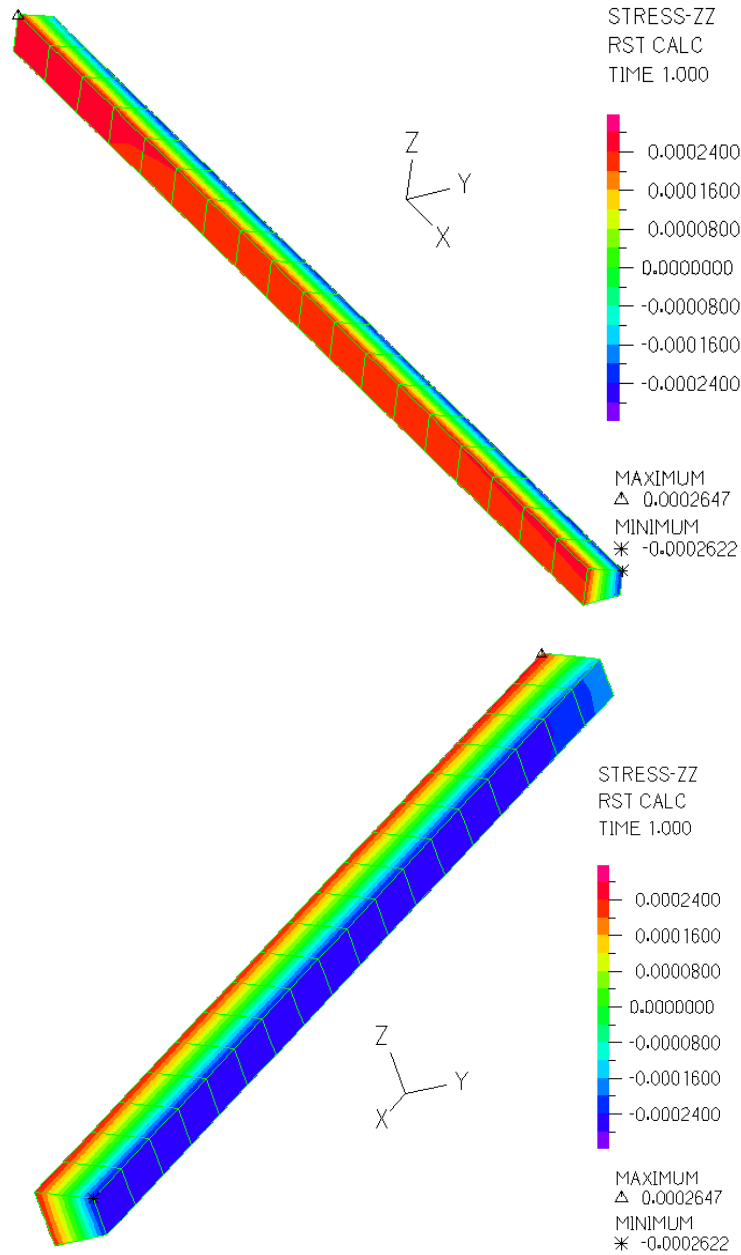
Rev No.: 0

Sheet 16 of 23



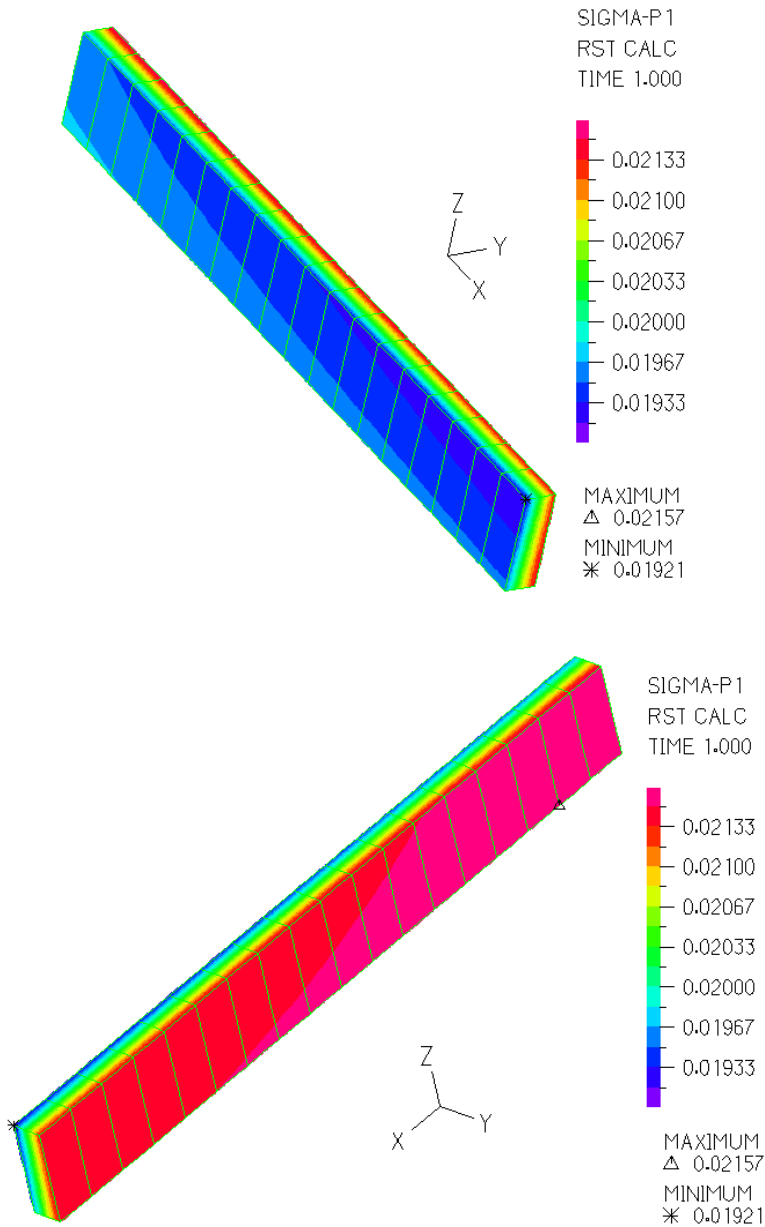
**Figure 3-8: Principal Tensile Stress (Sp1) Contour Plots at the Wall Element Zone 1 under a Torsion of 6202 kip-ft**

<b>I-90 Homer Hadley Floating Bridge – LRT Impacts</b>		<b>SC Solutions</b>
<b>Subject/Description:</b> <b>Torsional Analysis</b>	Originator: H.J. Lee	Date: 8/6/08
	Checked: Hassan Sedarat	Date: 8/6/08
Disclaimer: The analysis in this technical document is preliminary and is strictly to be used as advice in determining the feasibility of placing the LRT on the Homer Hadley Floating Bridge and approach spans. It is not intended for any other purpose or as the basis for any final design or construction issue associated with this project.	Calculation No.:TM-02	
	Rev No.: 0	Sheet 17 of 23



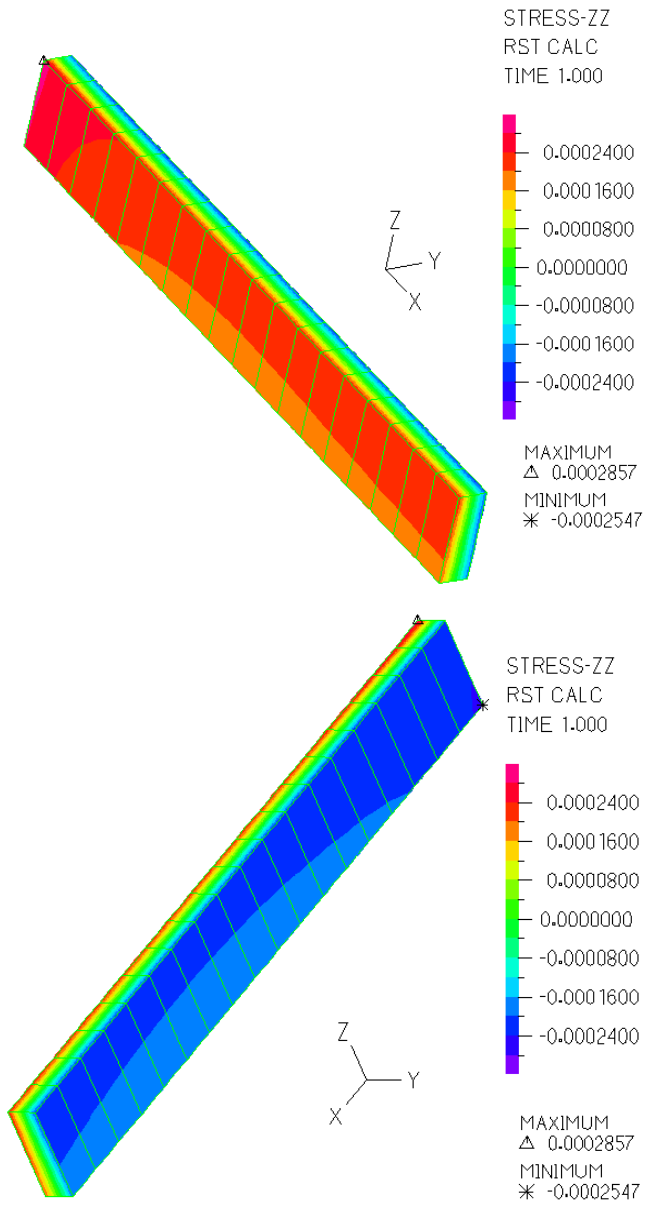
**Figure 3-9: Vertical Normal Stress (Szz) Contour Plots at the Wall Element Zone 1 under a Torsion of 6202 kip-ft**

<b>I-90 Homer Hadley Floating Bridge – LRT Impacts</b>		<b>SC Solutions</b>
<b>Subject/Description:</b> <b>Torsional Analysis</b>	Originator: H.J. Lee	Date: 8/6/08
	Checked: Hassan Sedarat	Date: 8/6/08
Disclaimer: The analysis in this technical document is preliminary and is strictly to be used as advice in determining the feasibility of placing the LRT on the Homer Hadley Floating Bridge and approach spans. It is not intended for any other purpose or as the basis for any final design or construction issue associated with this project.	Calculation No.:TM-02	
	Rev No.: 0	Sheet 18 of 23



**Figure 3-10: Principal Tensile Stress (Sp1) Contour Plots at the Wall Element Zone 2 under a Torsion of 6202 kip-ft**

<b>I-90 Homer Hadley Floating Bridge – LRT Impacts</b>		<b>SC Solutions</b>
<b>Subject/Description:</b> <b>Torsional Analysis</b>	Originator: H.J. Lee	Date: 8/6/08
	Checked: Hassan Sedarat	Date: 8/6/08
Disclaimer: The analysis in this technical document is preliminary and is strictly to be used as advice in determining the feasibility of placing the LRT on the Homer Hadley Floating Bridge and approach spans. It is not intended for any other purpose or as the basis for any final design or construction issue associated with this project.	Calculation No.:TM-02	
	Rev No.: 0	Sheet 19 of 23



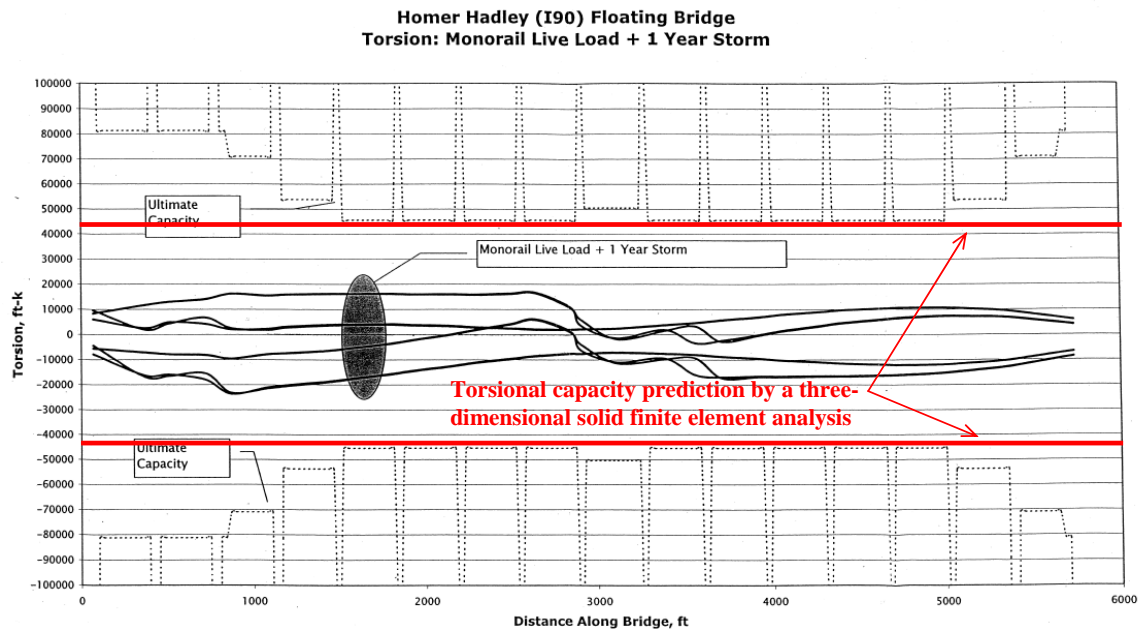
**Figure 3-11: Vertical Normal Stress ( $S_{zz}$ ) Contour Plots at the Wall Element Zone 2 under a Torsion of 6202 kip-ft**

I-90 Homer Hadley Floating Bridge – LRT Impacts		SC Solutions
Subject/Description: <b>Torsional Analysis</b>	Originator: H.J. Lee	Date: 8/6/08
	Checked: Hassan Sedarat	Date: 8/6/08
Disclaimer: The analysis in this technical document is preliminary and is strictly to be used as advice in determining the feasibility of placing the LRT on the Homer Hadley Floating Bridge and approach spans. It is not intended for any other purpose or as the basis for any final design or construction issue associated with this project.	Calculation No.:TM-02	
	Rev No.: 0	Sheet 20 of 23

#### 4. Conclusion

According to the coring memo for the samples taken from two of the pontoons on the I-90 Homer Hadley Bridge [3], the average concrete strength is about 7,090 psi. This was used to compute a torsional capacity of the bridge. From these test results, the acceptance criteria was calculated using an allowable stress of  $2\sqrt{f'_c}=2\sqrt{7090} = 168 \text{ psi} = 0.168 \text{ ksi}$ . Extrapolating a three-dimensional finite element analysis result to the allowable stress yields a torsional moment capacity of  $6202 \times 168/24 = 43,414 \text{ k-ft}$ . For the extrapolation, the maximum principal tensile stress value of 24 psi obtained from the finite element analysis was used. This torsional moment capacity prediction is similar to that by KPFF [5] as shown in **Figure 4-1**. The maximum torsional moment demand reported by KPFF [1] is 44,298 k-ft (**Figure 4-2**). This maximum torsional moment demand included a storm torsional load of 10,000 k-ft, which has now been reduced to about 1600 k-ft by Glostén Associates, Inc. The reduction in storm loading reduces the maximum torsional load to 35,898 k-ft. Therefore, the demand/capacity ratio is about 0.827, which means the bridge is good to go for these loads, provided the concrete strength can be used for the rest of the pontoons on the bridge. If we stay with the 5,000 psi concrete design strength, the allowable tensile stress is  $2\sqrt{f'_c}=2\sqrt{5000} = 141 \text{ psi} = 0.141 \text{ ksi}$  and the computed torsional capacity is  $6202 \times 141/24 = 36,437 \text{ k-ft}$ . Then, the demand/capacity ratio is about 0.985 and is still less than 1.0.

<b>I-90 Homer Hadley Floating Bridge – LRT Impacts</b>		<b>SC Solutions</b>
<b>Subject/Description:</b> <b>Torsional Analysis</b>	Originator: H.J. Lee	Date: 8/6/08
	Checked: Hassan Sedarat	Date: 8/6/08
Disclaimer: The analysis in this technical document is preliminary and is strictly to be used as advice in determining the feasibility of placing the LRT on the Homer Hadley Floating Bridge and approach spans. It is not intended for any other purpose or as the basis for any final design or construction issue associated with this project.	Calculation No.:TM-02	
	Rev No.: 0	Sheet 21 of 23



**Figure 4-1: Torsional Capacities presented in the KPFF Calc Book [5] (2005 - KPFF - I90 Structural Feasibility Study Monorail Conversion)**

<b>I-90 Homer Hadley Floating Bridge – LRT Impacts</b>		<b>SC Solutions</b>
<b>Subject/Description:</b> <b>Torsional Analysis</b>	Originator: H.J. Lee	Date: 8/6/08
	Checked: Hassan Sedarat	Date: 8/6/08
Disclaimer: The analysis in this technical document is preliminary and is strictly to be used as advice in determining the feasibility of placing the LRT on the Homer Hadley Floating Bridge and approach spans. It is not intended for any other purpose or as the basis for any final design or construction issue associated with this project.	Calculation No.:TM-02	
	Rev No.: 0	Sheet 22 of 23

<b>Pontoon Global Stress due to Pure Torsion at Mid-Span</b>					
Torsion					
Case	Max Torsion (ft-k)	Maximum Shearing Stresses, psi			
		Top Slab	Keel Slab	North Wall	South Wall
LRT only	20,075	94	-89	-74	74
LRT + Traffic	34,298	160	-153	-126	127
1-Year Storm only	10,000	47	-44	-37	37
LRT + Traffic + 1 Year Storm	44,298	207	-197	-163	164
<b>Pontoon Global Stress due to Pure Torsion at West End of Bridge</b>					
Torsion					
Case	Max Torsion (ft-k)	Maximum Shearing Stresses, psi			
		Top Slab	Keel Slab	North Wall	South Wall
LRT only	23,218	71	71	55	50
LRT + Traffic	23,218	71	71	55	50
1-Year Storm only	12,000	37	37	28	25
LRT + Traffic + 1-Year Storm	35,218	108	108	83	75

**Figure 4-2: Torsional Demands presented in the KPFF Calc Book [1] (2005 – KPFF Homer Hadley Bridge Structural Calculations)**

<b>I-90 Homer Hadley Floating Bridge – LRT Impacts</b>		<b>SC Solutions</b>
<b>Subject/Description:</b> <b>Torsional Analysis</b>	Originator: H.J. Lee	Date: 8/6/08
	Checked: Hassan Sedarat	Date: 8/6/08
Disclaimer: The analysis in this technical document is preliminary and is strictly to be used as advice in determining the feasibility of placing the LRT on the Homer Hadley Floating Bridge and approach spans. It is not intended for any other purpose or as the basis for any final design or construction issue associated with this project.	Calculation No.:TM-02	
	Rev No.: <b>0</b>	Sheet 23 of 23

## 5. References

1. KPFF calc book (2005 – KPFF Homer Hadley Bridge Structural Calculations)
2. ADINA version 8.3
3. CH2M HILL and Mayes Technical Memorandum (May 7, 2008 – Sound Transit East Link Project – IRT Issue – Homer Hadley Floating Bridge Core Drilled Concrete Specimens
4. Drawings: As built drawings
5. KPFF calc book (2005 – I90 Structural Feasibility Study Monorail Conversion – Appendix A)



**I-90 Homer Hadley Floating Bridge – LRT Impacts  
Technical Memorandum Cover Sheet**

**Technical Memorandum TM-03  
Expansion Joint Analysis**

**Prepared by: SC Solutions**  
**Date: August 6, 2008**

**Disclaimer:**

The analysis in this technical document is preliminary and is strictly to be used as advice in determining the feasibility of placing the LRT on the Homer Hadley Floating Bridge and approach spans. It is not intended for any other purpose or as the basis for any final design or construction issue associated with this project.

<b>I-90 Homer Hadley Floating Bridge – LRT Impacts</b>		<b>SC Solutions</b>
<b>Subject/Description: Expansion Joint Model</b>	Originator: Alexander Kozak	Date: 8/6/2008
	Checked: T. E. Abrahamson	Date: 8/6/2008
Disclaimer: The analysis in this technical document is preliminary and is strictly to be used as advice in determining the feasibility of placing the LRT on the Homer Hadley Floating Bridge and approach spans. It is not intended for any other purpose or as the basis for any final design or construction issue associated with this project	Calculation No.:TM-03	
	Rev No.: 0	Sheet 2 of 38

### Table of Contents

1. Introduction.....	3
2. Basis for Analysis and References.....	4
3. Discussion.....	4
3.1 Model Description .....	4
3.1.1 Geometry.....	4
3.1.2 Boundary Conditions .....	14
3.1.3 Loading .....	14
3.2 Analysis Results.....	19
3.2.1 Individual Joint Motions.....	19
3.2.1.1 Case 1: Longitudinal Translation.....	19
3.2.1.2 Case 2: Vertical Rotation.....	19
3.2.1.3 Case 3: Horizontal Rotation.....	21
3.2.2 Combined Maximum Vertical and Lateral Rotations.....	22
3.2.2.1 Case 4: Maximum Vertical and Lateral Rotations, No Wheel Loads..	23
3.2.2.2 Cases 5, 6, and 7: Combined Loads at 75%, 50%, and 25% .....	29
3.2.2.3 Case 8: Lateral rotation and vehicle wheel reactions.....	29
3.2.2.4 Case 9: Combined maximum vertical and lateral rotation and vehicle wheel reactions.....	33
4. Conclusions.....	38

<b>I-90 Homer Hadley Floating Bridge – LRT Impacts</b>		<b>SC Solutions</b>
<b>Subject/Description: Expansion Joint Model</b>	Originator: Alexander Kozak	Date: 8/6/2008
	Checked: T. E. Abrahamson	Date: 8/6/2008
Disclaimer: The analysis in this technical document is preliminary and is strictly to be used as advice in determining the feasibility of placing the LRT on the Homer Hadley Floating Bridge and approach spans. It is not intended for any other purpose or as the basis for any final design or construction issue associated with this project	Calculation No.:TM-03	
	Rev No.: 0	Sheet 3 of 38

## 1. Introduction

This analysis examined the effect of expansion joint motions on the stresses in the rails and provided the rail shape information for the vehicle dynamics analysis. The expansion joints connect the transition spans to the floating spans of the bridge. Changing water levels and horizontal motions of the floating spans can cause rotational displacements in the expansion joints. These rotations cause stresses in the rails. The rails are supported by a three beam system, which smoothes the transition across the expansion joint.

The analysis was conducted with preliminary data, not final data on the design of the expansion joint three beam track bridge. In addition, the actual design load conditions were not fully defined. Therefore, this should be considered to be a preliminary study, which should not be used for final design. This memo is provided to convey the results of this study.

The analysis found that motions of the expansion joint can cause large stresses in the rails, depending on the level of load considered. The design rotations are 2.2° vertical and 1.1° horizontal rotation. If these are combined at 100% each, then the stress would be about 62 ksi, without any train live load. The train live load causes an additional 4 ksi in the rail. If the rotations are limited to the “ultimate event”, with rotations of 1.25° vertical and 1° horizontal, the stresses are reduced to about 47 ksi, again without the train live load. At the level of the “annual event” (0.4° vertical, 0.2° horizontal rotation), the rail stresses become about 16 ksi.

The ultimate event is a storm condition, during which the trains would not cross the bridge. The minimum level load defined was the “annual event”, which probably also includes some storm components. The live load of the train should only be included in this case. Using the 4 ksi live load computed at the worst case combination, the stress in the rails for the annual event becomes about 20 ksi. The strength of the rail material is 67 ksi, so this is well within the strength capacity of the rails.

The analysis also examined the effect of the train on the deformations of the rails and track bridge. The train loads had a negligible effect on the deformations of the rails, so a full vehicle / rail dynamic interaction model is not required.

<b>I-90 Homer Hadley Floating Bridge – LRT Impacts</b>		<b>SC Solutions</b>
<b>Subject/Description: Expansion Joint Model</b>	Originator: Alexander Kozak	Date: 8/6/2008
	Checked: T. E. Abrahamson	Date: 8/6/2008
Disclaimer: The analysis in this technical document is preliminary and is strictly to be used as advice in determining the feasibility of placing the LRT on the Homer Hadley Floating Bridge and approach spans. It is not intended for any other purpose or as the basis for any final design or construction issue associated with this project	Calculation No.:TM-03	
	Rev No.: 0	Sheet 4 of 38

## 2. Basis for Analysis and References

1. Sound Transit East Link Project Team. "Eastside HCT Corridor. I-90 Floating Bridge (Homer Hadley). Expansion Joint. Final Conceptual Report". January, 2008.
2. ADINA v. 8.4, ADINA R&D, Inc, 2007
3. SoundTransit Link Design Criteria, 2005
4. Jersey Shore Steel Company (<http://www.jssteel.com/steel-angle/specifications.asp>)
5. Vehicle Dynamics Tech Memo

The geometry of the expansion joint and track bridge were defined in [1]. The loads were also summarized in this reference. The design criteria are defined in [3]. All analysis was performed using ADINA v. 8.4 [2]. Rail material properties were found at the Jersey Shore Steel Company [4].

## 3. Discussion

### 3.1 Model Description

#### 3.1.1 Geometry

The approaches to the floating bridge travel downward from the shore, where they are fixed to the ground, and connect to the floating bridge, which is moored on the surface of the lake. The floating portion of the bridge can move in 3 directions, due to changing water levels in the lake, and horizontal drifting of the bridge in the water. A transition structure is required to accommodate the differences in motion between the fixed and moving spans. The transition span rests on the last bent cap of the approach structure, which bearings that allow rotation of the deck in 2 axes. At the floating end, the transition span rests on the first pontoon of the floating bridge, with an expansion joint to accommodate the floating deck movements.

Motion of the bridge will change the angle between the transition span and the floating spans. If the rail were attached directly to the decks of the transition and floating spans, then the change in angle would occur as a sharp bend at the expansion joint. This would be an unacceptable kink in the rail. Instead, a track bridge was designed to spread the bend over a long curve.

<b>I-90 Homer Hadley Floating Bridge – LRT Impacts</b>		<b>SC Solutions</b>
<b>Subject/Description: Expansion Joint Model</b>	Originator: Alexander Kozak	Date: 8/6/2008
	Checked: T. E. Abrahamson	Date: 8/6/2008
Disclaimer: The analysis in this technical document is preliminary and is strictly to be used as advice in determining the feasibility of placing the LRT on the Homer Hadley Floating Bridge and approach spans. It is not intended for any other purpose or as the basis for any final design or construction issue associated with this project	Calculation No.:TM-03	
	Rev No.: 0	Sheet 5 of 38

The track bridge concept is described in [1]. In the concept study, the center beam of the track bridge was 22’6” long. Because of high loads experienced in the original study, the length was increased to 30 ft.

The model geometry was generated according to the sketches in [1], in an excel file. The model was generated for ADINA v. 8.4 [2]. An overall plot of the model is shown in Figure 3-1. The “fixed span” represents the transition spans. The actual transition spans are 192 and 202 ft long, while those in the model were 450 ft. This was to provide room for the vehicle dynamics model and a model analyzing the dynamic interaction between the vehicle and the track bridge / expansion joint model. The loads were always applied as local rotations or deformations measured at the expansion joint, so the addition length of the transition span was irrelevant.

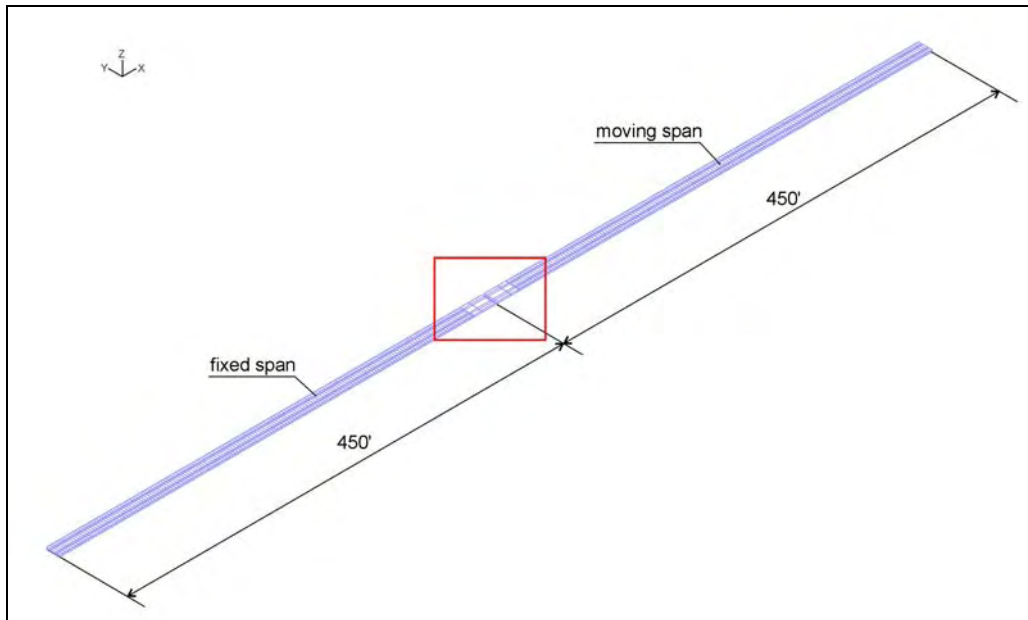
A detailed plot of the expansion joints is shown in Figure 3-2. A sketch of the track bridge is shown in Figure 3-3. It is supported on rollers on both ends, and is centered by a system of cables attached to the transition and floating spans (Figure 3-4). This track bridge structure was modeled in detail, and attached to the top of the deck models (Figure 3-5, Figure 3-6). Note that the original concept called for a significant recess to be cut into both decks, so that the track bridge would not be much higher than the deck. This has very little effect on this analysis, since the deck is much stiffer than the track bridge. Therefore, the recess was not included in this model. The track bridge was placed directly on the top of the deck slab section.

There are two locations at each rail (at each side of the transfer beam system) where the axial force is released and not transmitted (see Figure 3-6). This allows longitudinal motion of the floating bridge with respect to the shore, without applying stress to the rail.

Dimensions used in generating the model are summarized in Table 3-1. This table also lists the source or the data, or states that it was assumed.

Dimensioned cross-sections of the three-beam transition system elements are shown in Figure 3-7.

<b>I-90 Homer Hadley Floating Bridge – LRT Impacts</b>		<b>SC Solutions</b>
<b>Subject/Description: Expansion Joint Model</b>	Originator: Alexander Kozak	Date: 8/6/2008
	Checked: T. E. Abrahamson	Date: 8/6/2008
Disclaimer: The analysis in this technical document is preliminary and is strictly to be used as advice in determining the feasibility of placing the LRT on the Homer Hadley Floating Bridge and approach spans. It is not intended for any other purpose or as the basis for any final design or construction issue associated with this project	Calculation No.:TM-03	
	Rev No.: 0	Sheet 6 of 38



**Figure 3-1: Expansion Joint Model – Total View – Dimensions in Feet.**

Subject/Description: **Expansion Joint Model**

Originator: Alexander Kozak Date: 8/6/2008

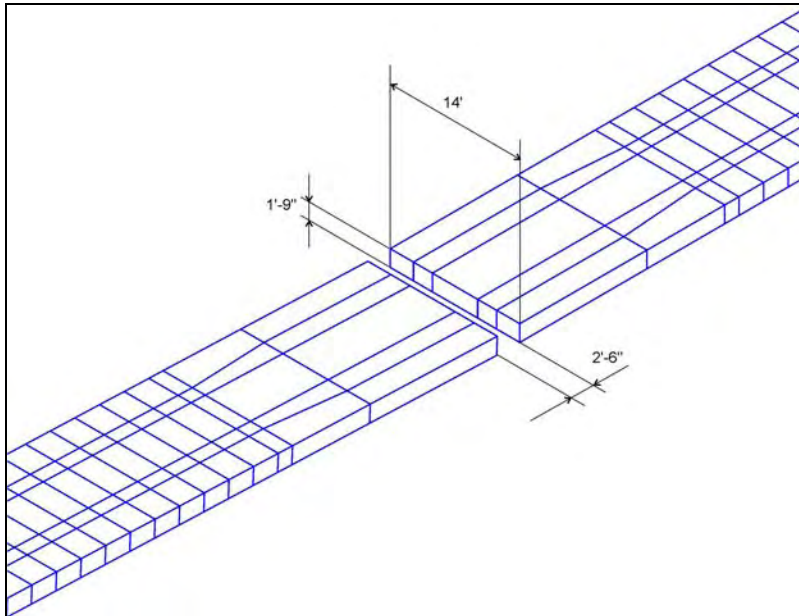
Checked: T. E. Abrahamson Date: 8/6/2008

Disclaimer: The analysis in this technical document is preliminary and is strictly to be used as advice in determining the feasibility of placing the LRT on the Homer Hadley Floating Bridge and approach spans. It is not intended for any other purpose or as the basis for any final design or construction issue associated with this project

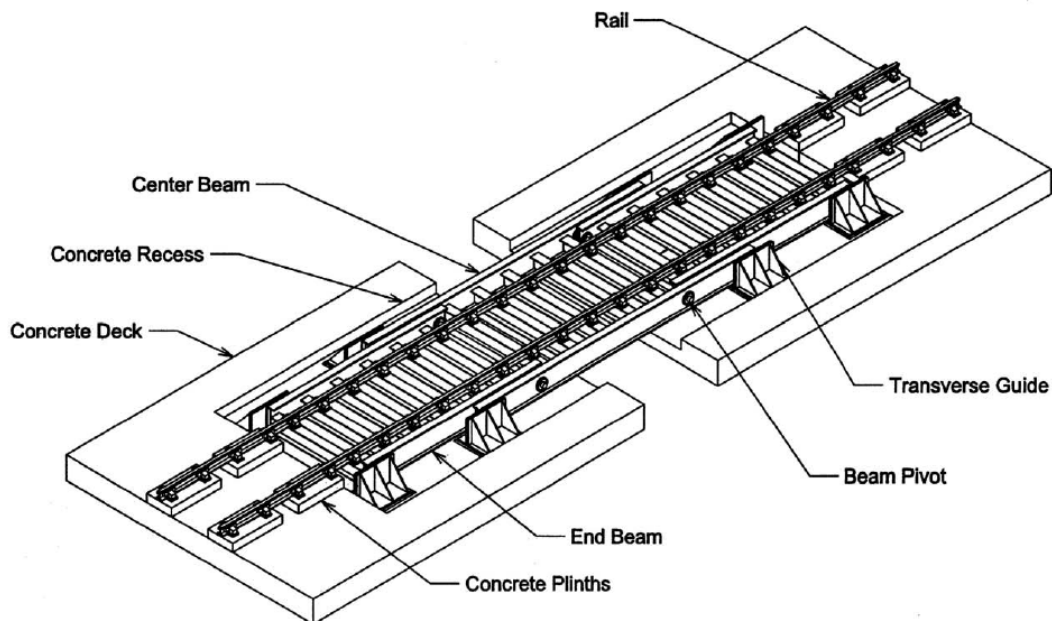
Calculation No.:TM-03

Rev No.: 0

Sheet 7 of 38

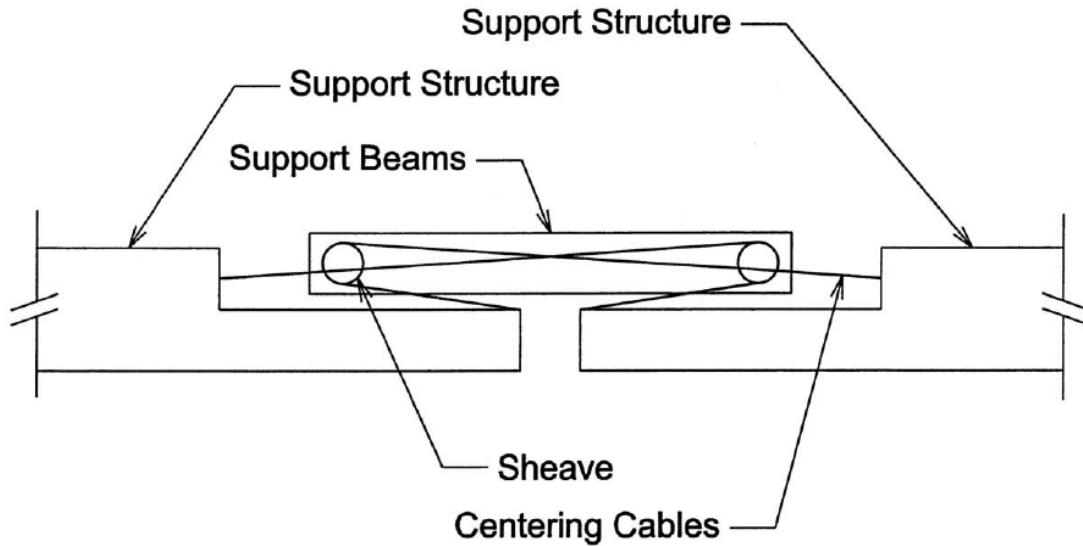


**Figure 3-2: Expansion Joint Model – Span Connection Area – Dimensions in Feet and Inches.**



<b>I-90 Homer Hadley Floating Bridge – LRT Impacts</b>		<b>SC Solutions</b>
<b>Subject/Description: Expansion Joint Model</b>	Originator: Alexander Kozak	Date: 8/6/2008
	Checked: T. E. Abrahamson	Date: 8/6/2008
Disclaimer: The analysis in this technical document is preliminary and is strictly to be used as advice in determining the feasibility of placing the LRT on the Homer Hadley Floating Bridge and approach spans. It is not intended for any other purpose or as the basis for any final design or construction issue associated with this project	Calculation No.:TM-03	
	Rev No.: 0	Sheet 8 of 38

**Figure 3-3: Track Beam Sketch (from [1])**



**Figure 3-4: Cable System for Centering the Track Bridge (from [1])**



Subject/Description: **Expansion Joint Model**

Originator: Alexander Kozak Date: 8/6/2008

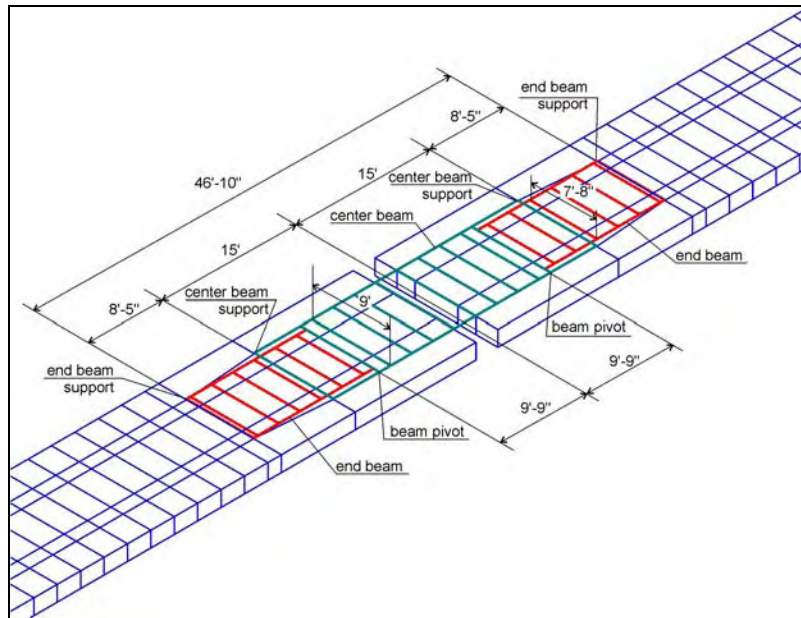
Checked: T. E. Abrahamson Date: 8/6/2008

Disclaimer: The analysis in this technical document is preliminary and is strictly to be used as advice in determining the feasibility of placing the LRT on the Homer Hadley Floating Bridge and approach spans. It is not intended for any other purpose or as the basis for any final design or construction issue associated with this project

Calculation No.:TM-03

Rev No.: 0

Sheet 9 of 38



**Figure 3-5: Expansion Joint Model – Three-Beam Transition System – Dimensions in Feet and Inches.**

Subject/Description: **Expansion Joint Model**

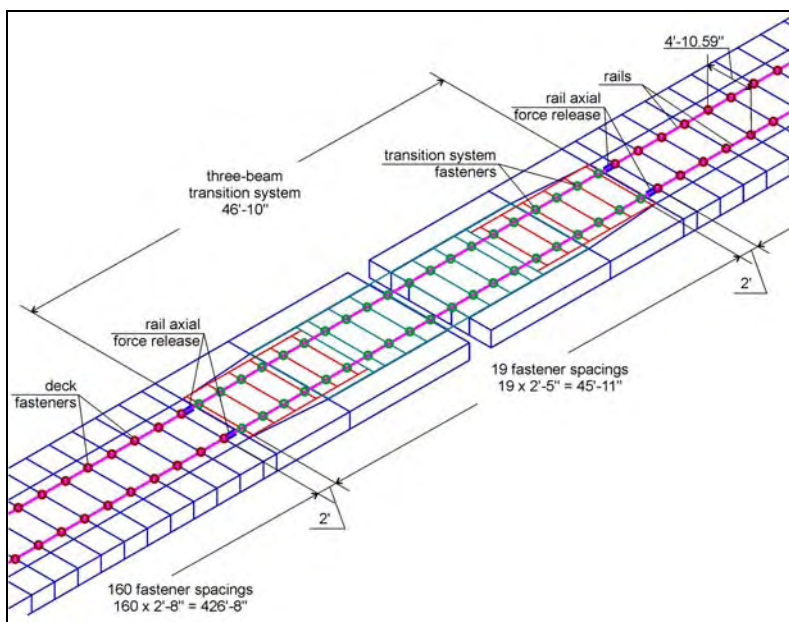
Originator: Alexander Kozak Date: 8/6/2008

Checked: T. E. Abrahamson Date: 8/6/2008

Disclaimer: The analysis in this technical document is preliminary and is strictly to be used as advice in determining the feasibility of placing the LRT on the Homer Hadley Floating Bridge and approach spans. It is not intended for any other purpose or as the basis for any final design or construction issue associated with this project

Calculation No.:TM-03

Rev No.: **0** Sheet 10 of 38



**Figure 3-6: Expansion Joint Model – Rails and Fasteners – Dimensions in Feet and Inches.**

**Table 3-1: Model Dimensions.**

	Dimension	ft-in	Description
1	normal spacing between the decks	2'-6"	see comment 1 below
2	deck thickness	1'-9"	assumption
3	deck width	14'-0"	assumption
4	distance from the expansion joint CL to the center beam support	15'-0"	half of center beam length (0.5x30')
5	distance from the expansion joint CL to the beam pivot	9'-9"	see comment 2 below
6	end beam length from the beam pivot	8'-5"	[1]
7	distance between the axes of the end beam longitudinal elements	7'-8"	[1]

<b>I-90 Homer Hadley Floating Bridge – LRT Impacts</b>		<b>SC Solutions</b>
<b>Subject/Description: Expansion Joint Model</b>	Originator: Alexander Kozak	Date: 8/6/2008
	Checked: T. E. Abrahamson	Date: 8/6/2008
Disclaimer: The analysis in this technical document is preliminary and is strictly to be used as advice in determining the feasibility of placing the LRT on the Homer Hadley Floating Bridge and approach spans. It is not intended for any other purpose or as the basis for any final design or construction issue associated with this project	Calculation No.:TM-03	
	Rev No.: 0	Sheet 11 of 38

8	distance between the axes of the center beam longitudinal elements	9'-0"	[1]
9	fastener spacing within the transition system	2'-5"	[1]
10	fastener spacing at the deck	2'-8"	[1]
11	fastener spacing within the last transition system fastener and the first of the deck	2'-0"	[1]
12	distance between the rail axes	4'-10.59"	Based on Track Gauge [3]

1. Maximum longitudinal translational movement at the expansion joint is  $\pm 24.5''$ . Minimum gap between the decks is assumed equal to  $5.5''$ . Then, normal spacing is  $(5.5'' + 24.5'') = 30'' = 2'-6''$ .
2. Distance between beam pivots ( $19'-6''$  according to [1]) is increased correspondingly to the increased center beam length ( $30''$ ).

Subject/Description: **Expansion Joint Model**

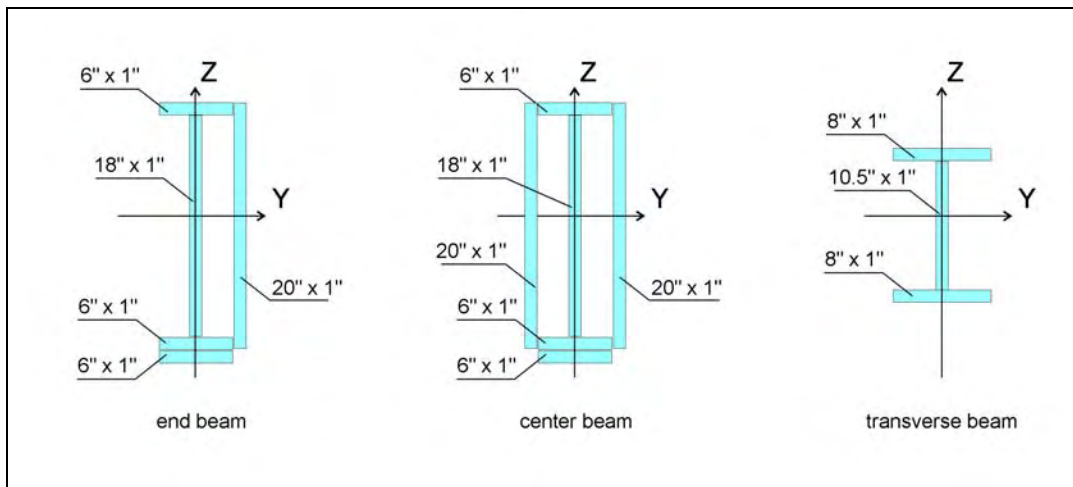
Originator: Alexander Kozak Date: 8/6/2008

Checked: T. E. Abrahamson Date: 8/6/2008

Disclaimer: The analysis in this technical document is preliminary and is strictly to be used as advice in determining the feasibility of placing the LRT on the Homer Hadley Floating Bridge and approach spans. It is not intended for any other purpose or as the basis for any final design or construction issue associated with this project

Calculation No.:TM-03

Rev No.: 0 Sheet 12 of 38



**Figure 3-7: Expansion Joint Model – Three-Beam Transition System Element Cross-Sections – Dimensions in Inches.**

The rail is defined as a 115 lb. RE rail, with a cross section as shown in Figure 3-8.

Cross-section properties are given at Harmer Steel web site [2] for area and bending moment about a horizontal axis (vertical bending). However, the moment of inertia about a vertical axis (horizontal bending) and torsional moment of inertia, are not available. Those were computed, as shown in Table 3-2.

**Table 3-2: Rail Section Properties**

Property	115 lb. RE rail
Area (in <sup>2</sup> )	11.25
Moment of Inertial about horizontal axis (in <sup>4</sup> )	65.6
Moment of Inertial about vertical axis (in <sup>4</sup> )	11.58
Torsional moment of inertia (in <sup>4</sup> )	1.1

Subject/Description: **Expansion Joint Model**

Originator: Alexander Kozak Date: 8/6/2008

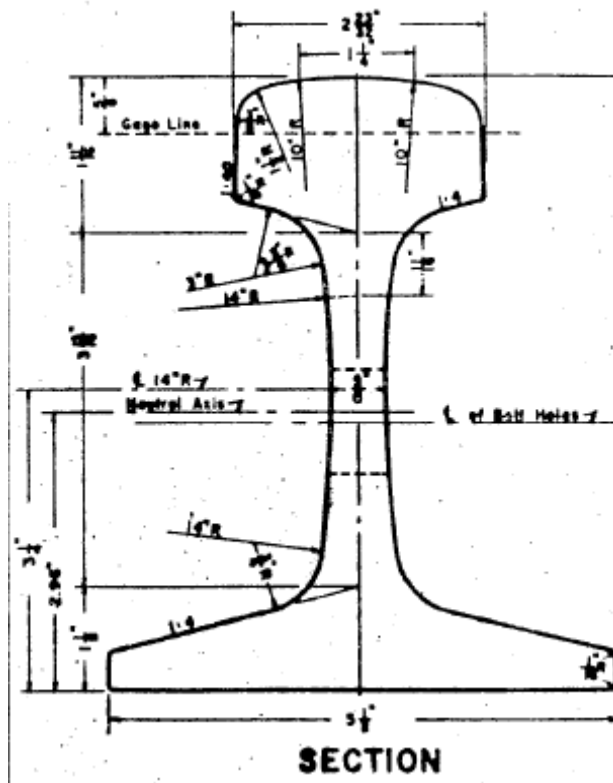
Checked: T. E. Abrahamson Date: 8/6/2008

Disclaimer: The analysis in this technical document is preliminary and is strictly to be used as advice in determining the feasibility of placing the LRT on the Homer Hadley Floating Bridge and approach spans. It is not intended for any other purpose or as the basis for any final design or construction issue associated with this project

Calculation No.: TM-03

Rev No.: 0

Sheet 13 of 38



**Figure 3-8: 115 LB RE Rail, Cross Section, Dimensions in Inches.**

The only component in this structure in which stresses were examined was the rails. Stresses in the remaining structure were not considered. According to Jersey Shore Steel Company [4], the rail steel averaged yield stress is 67 ksi.

Each rail fastener was modeled with three linear spring finite elements, oriented in the longitudinal, transverse and vertical directions. Stiffness of a fastener connected directly to the deck was assumed different from that of the fasteners within the three-beam transition system (Table 3-3).

<b>I-90 Homer Hadley Floating Bridge – LRT Impacts</b>		<b>SC Solutions</b>
<b>Subject/Description: Expansion Joint Model</b>	Originator: Alexander Kozak	Date: 8/6/2008
	Checked: T. E. Abrahamson	Date: 8/6/2008
Disclaimer: The analysis in this technical document is preliminary and is strictly to be used as advice in determining the feasibility of placing the LRT on the Homer Hadley Floating Bridge and approach spans. It is not intended for any other purpose or as the basis for any final design or construction issue associated with this project	Calculation No.:TM-03	
	Rev No.: 0	Sheet 14 of 38

**Table 3-3: Rail Fastener Stiffness**

Location	Direction	Stiffness
		kip/in
deck	longitudinal	28
	transverse	420
	vertical	420,000
transition system	longitudinal	28
	transverse	28
	vertical	420,000

### 3.1.2 Boundary Conditions

In all load cases, the deck sections were moved in order to generate displacement or rotational discontinuities in the expansion joint. Displaced positions of the decks were enforced for each load case. There were no other boundary conditions.

### 3.1.3 Loading

The expansion joint model was subjected to three joint movement loadings, as cited in [1]:

- Case 1: Maximum longitudinal (X) translation = 24.5” (Figure 3-9).
- Case 2: Maximum vertical (YY) rotation = 2.2° (Figure 3-10).
- Case 3: Maximum horizontal (ZZ) rotation = 1.1° (Figure 3-11).

Additional cases combining the expansion joint rotational deformations were run:

- Case 4: Maximum vertical and lateral rotations (Figure 3-12).
- Case 5: ¾ Maximum vertical and lateral rotations (Figure 3-13).
- Case 6: ½ Maximum vertical and lateral rotations (Figure 3-14).
- Case 7: ¼ Maximum vertical and lateral rotations (Figure 3-15).

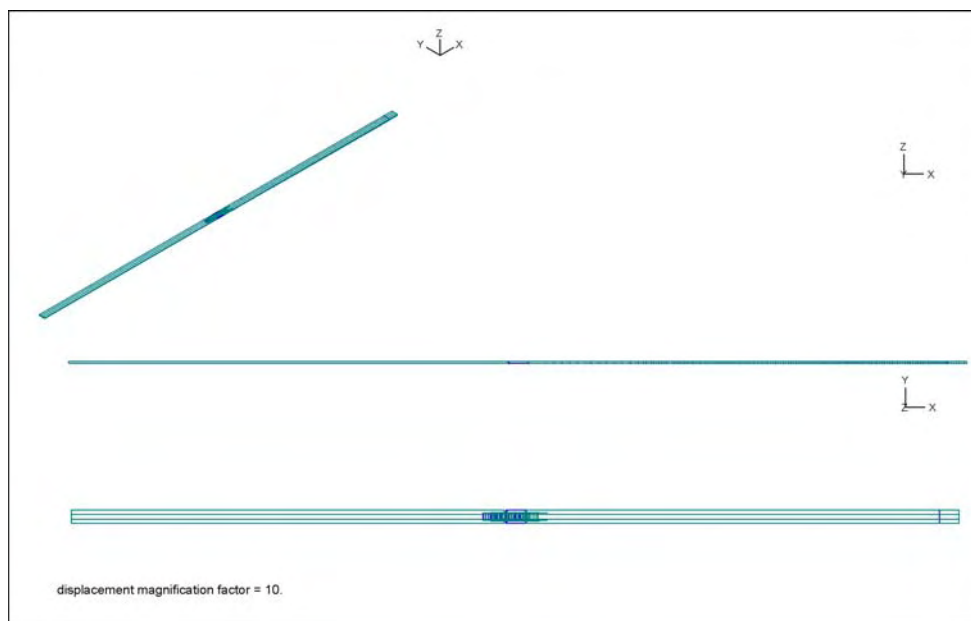
One final case was run in which the wheel reactions due to a vehicle dynamic model on the deformed expansion joint model were imposed on the rails of the deformed model:

<b>I-90 Homer Hadley Floating Bridge – LRT Impacts</b>		<b>SC Solutions</b>
<b>Subject/Description: Expansion Joint Model</b>	Originator: Alexander Kozak	Date: 8/6/2008
	Checked: T. E. Abrahamson	Date: 8/6/2008
Disclaimer: The analysis in this technical document is preliminary and is strictly to be used as advice in determining the feasibility of placing the LRT on the Homer Hadley Floating Bridge and approach spans. It is not intended for any other purpose or as the basis for any final design or construction issue associated with this project	Calculation No.:TM-03	
	Rev No.: 0	Sheet 15 of 38

Case 8: Wheel loads in combination with horizontal rotation (case 3)

Case 9: Wheel loads in combination with horizontal rotation (case 2)

Stresses in the rails were only computed for cases 4 and 9.



**Figure 3-9: Maximum Longitudinal (X) Translation – Deformed Mesh.**

Subject/Description: **Expansion Joint Model**

Originator: Alexander Kozak Date: 8/6/2008

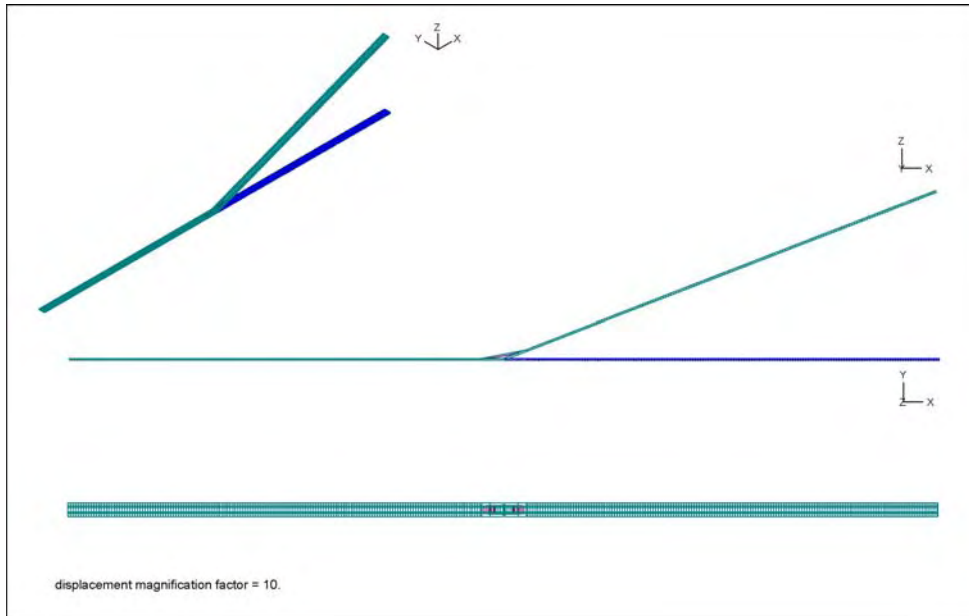
Checked: T. E. Abrahamson Date: 8/6/2008

Disclaimer: The analysis in this technical document is preliminary and is strictly to be used as advice in determining the feasibility of placing the LRT on the Homer Hadley Floating Bridge and approach spans. It is not intended for any other purpose or as the basis for any final design or construction issue associated with this project

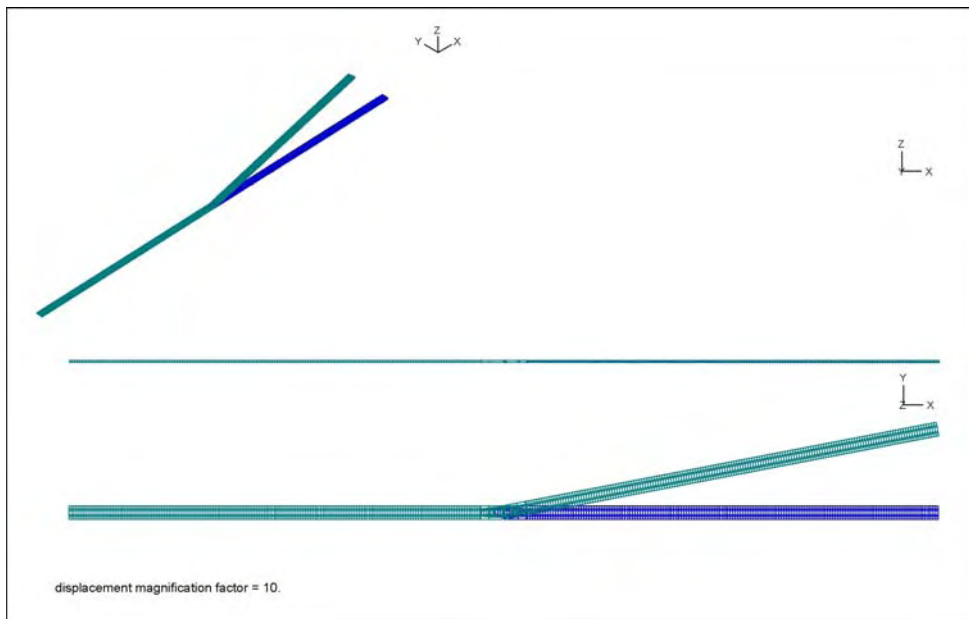
Calculation No.:TM-03

Rev No.: **0**

Sheet 16 of 38



**Figure 3-10: Maximum Vertical (YY) Rotation – Deformed Mesh.**



**Figure 3-11: Maximum Lateral (ZZ) Rotation – Deformed Mesh.**



Subject/Description: **Expansion Joint Model**

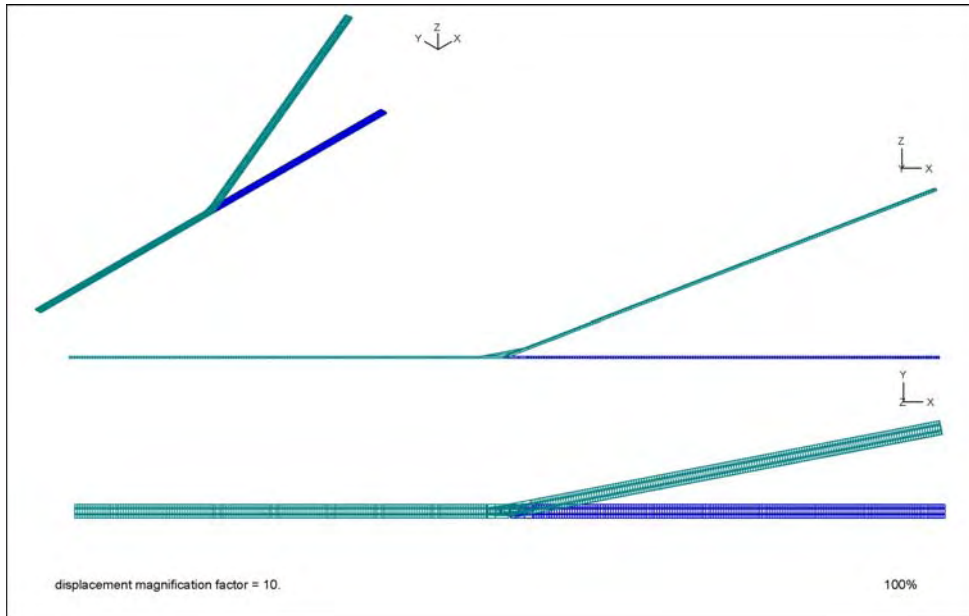
Originator: Alexander Kozak Date: 8/6/2008

Checked: T. E. Abrahamson Date: 8/6/2008

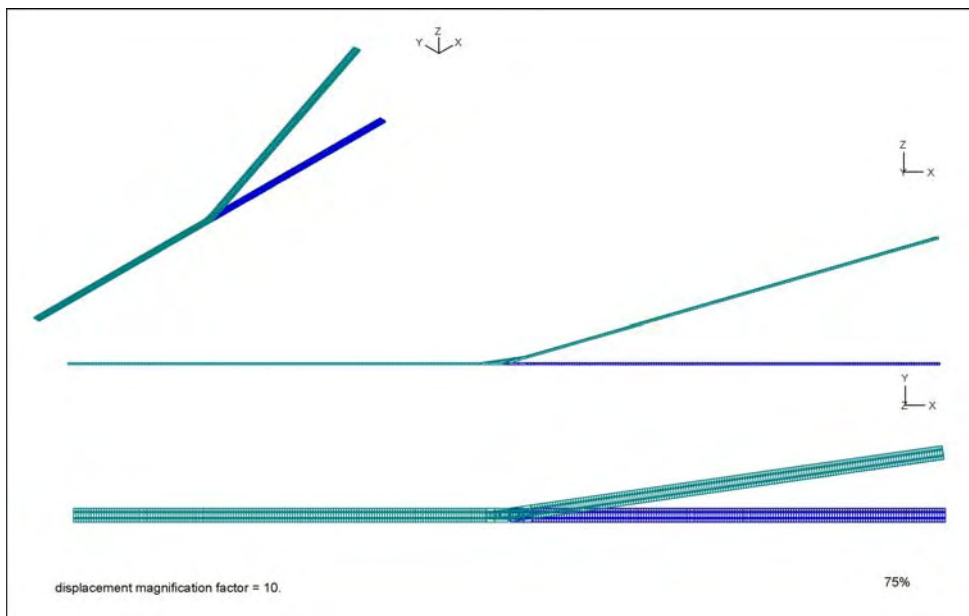
Disclaimer: The analysis in this technical document is preliminary and is strictly to be used as advice in determining the feasibility of placing the LRT on the Homer Hadley Floating Bridge and approach spans. It is not intended for any other purpose or as the basis for any final design or construction issue associated with this project

Calculation No.:TM-03

Rev No.: **0** Sheet 17 of 38



**Figure 3-12: Combined Maximum Vertical (YY) and Lateral (ZZ) Rotation – Deformed Mesh.**



**Figure 3-13: Combined 3/4 Maximum Vertical (YY) and Lateral (ZZ) Rotation – Deformed Mesh.**

Subject/Description: **Expansion Joint Model**

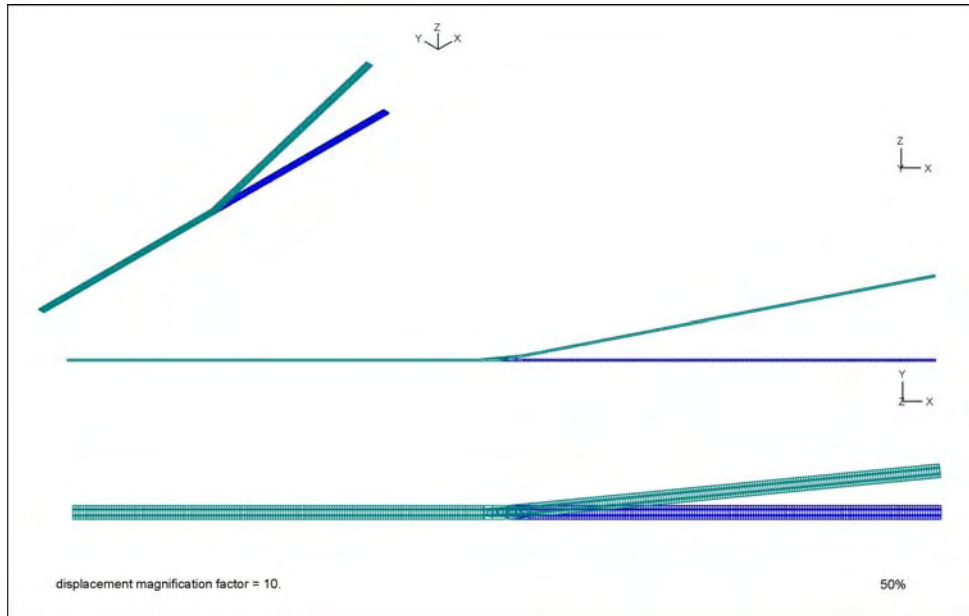
Originator: Alexander Kozak Date: 8/6/2008

Checked: T. E. Abrahamson Date: 8/6/2008

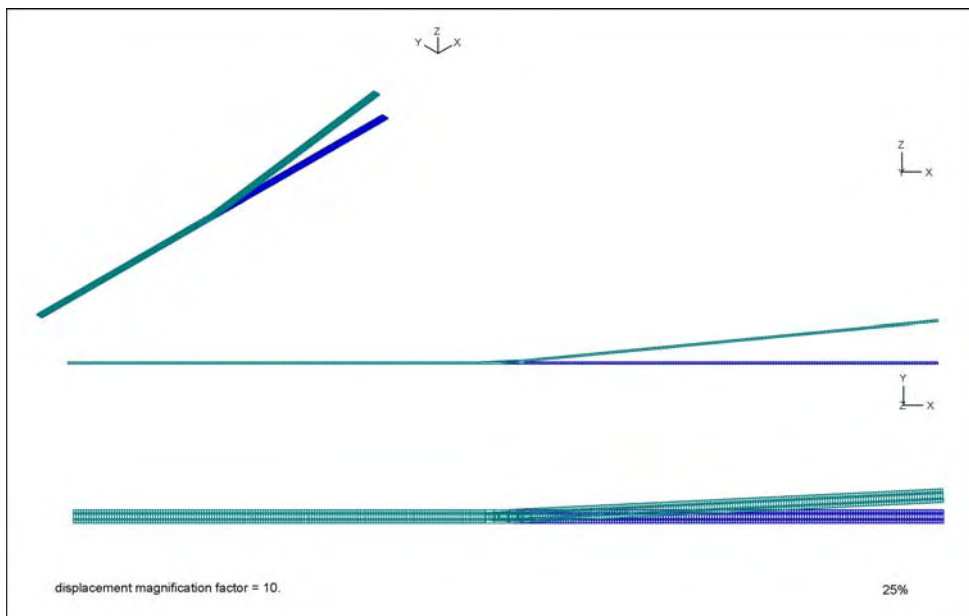
Disclaimer: The analysis in this technical document is preliminary and is strictly to be used as advice in determining the feasibility of placing the LRT on the Homer Hadley Floating Bridge and approach spans. It is not intended for any other purpose or as the basis for any final design or construction issue associated with this project

Calculation No.:TM-03

Rev No.: **0** Sheet 18 of 38



**Figure 3-14: Combined 1/2 Maximum Vertical (YY) and Lateral (ZZ) Rotation – Deformed Mesh.**



**Figure 3-15: Combined 1/4 Maximum Vertical (YY) and Lateral (ZZ) Rotation – Deformed Mesh.**

<b>I-90 Homer Hadley Floating Bridge – LRT Impacts</b>		<b>SC Solutions</b>
<b>Subject/Description: Expansion Joint Model</b>	Originator: Alexander Kozak	Date: 8/6/2008
	Checked: T. E. Abrahamson	Date: 8/6/2008
Disclaimer: The analysis in this technical document is preliminary and is strictly to be used as advice in determining the feasibility of placing the LRT on the Homer Hadley Floating Bridge and approach spans. It is not intended for any other purpose or as the basis for any final design or construction issue associated with this project	Calculation No.:TM-03	
	Rev No.: 0	Sheet 19 of 38

## 3.2 Analysis Results

### 3.2.1 Individual Joint Motions

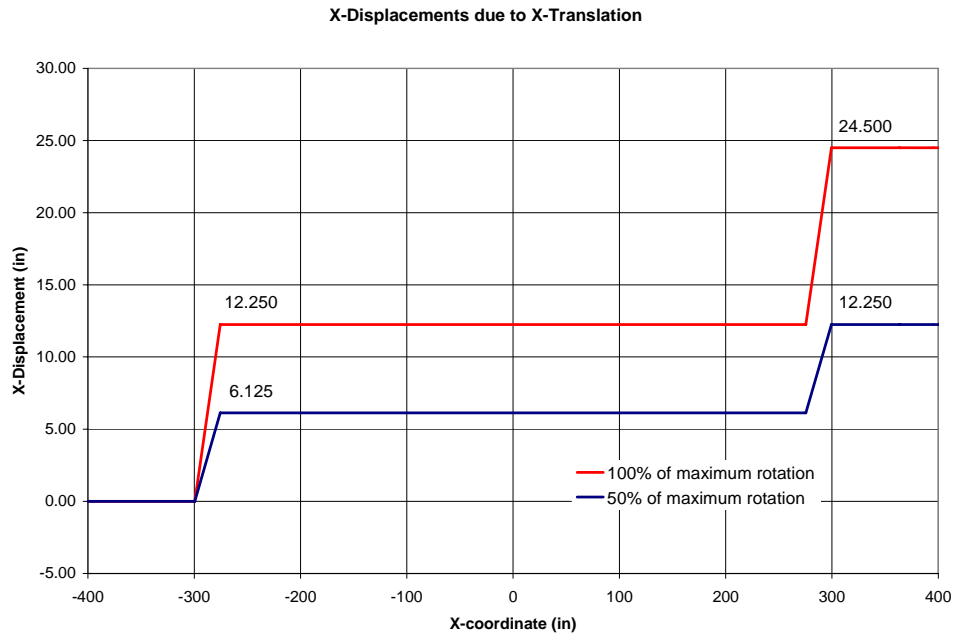
#### 3.2.1.1 Case 1: Longitudinal Translation

The rail nodal displacements in vicinity of the joint are given for the maximum and 50% of maximum joint movements for the longitudinal translation case (Figure 3-16). As expected, all of the deformation in the rail occurs in the two rail expansion joints. This expansion occurs with no force accumulation, so the stress in the rail is negligible.

#### 3.2.1.2 Case 2: Vertical Rotation

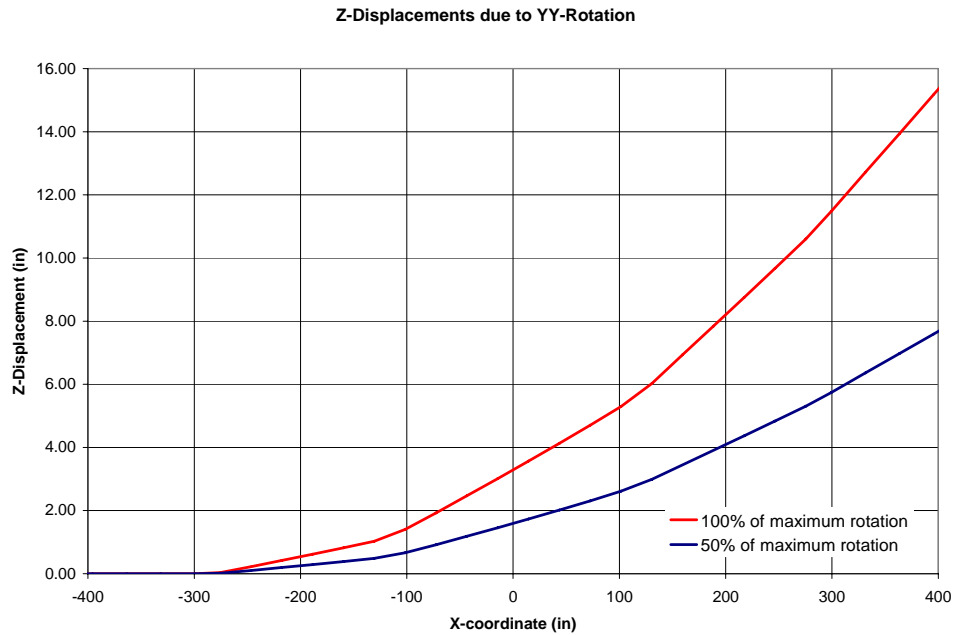
When the water level in the lake changes, the vertical angle of the rail may change. The rail nodal displacements in vicinity of the joint are given for the maximum and 50% of maximum joint movements for the vertical rotation case (Figure 3-17). The rotation was postulated in [1] to cause a uniform circular curve along the track bridge structure. However, Figure 3-17 shows that the track curvature is concentrated in two locations, at either end of the track bridge. This leads to high rail stresses in those regions, and high train car accelerations as the train passes these locations.

<b>I-90 Homer Hadley Floating Bridge – LRT Impacts</b>		<b>SC Solutions</b>
<b>Subject/Description: Expansion Joint Model</b>	Originator: Alexander Kozak	Date: 8/6/2008
	Checked: T. E. Abrahamson	Date: 8/6/2008
Disclaimer: The analysis in this technical document is preliminary and is strictly to be used as advice in determining the feasibility of placing the LRT on the Homer Hadley Floating Bridge and approach spans. It is not intended for any other purpose or as the basis for any final design or construction issue associated with this project	Calculation No.:TM-03	
	Rev No.: 0	Sheet 20 of 38



**Figure 3-16: Rail Longitudinal (X) Displacements due to Joint Longitudinal (X) Translation.**

<b>I-90 Homer Hadley Floating Bridge – LRT Impacts</b>		<b>SC Solutions</b>
<b>Subject/Description: Expansion Joint Model</b>	Originator: Alexander Kozak	Date: 8/6/2008
	Checked: T. E. Abrahamson	Date: 8/6/2008
Disclaimer: The analysis in this technical document is preliminary and is strictly to be used as advice in determining the feasibility of placing the LRT on the Homer Hadley Floating Bridge and approach spans. It is not intended for any other purpose or as the basis for any final design or construction issue associated with this project	Calculation No.:TM-03	
	Rev No.: 0	Sheet 21 of 38

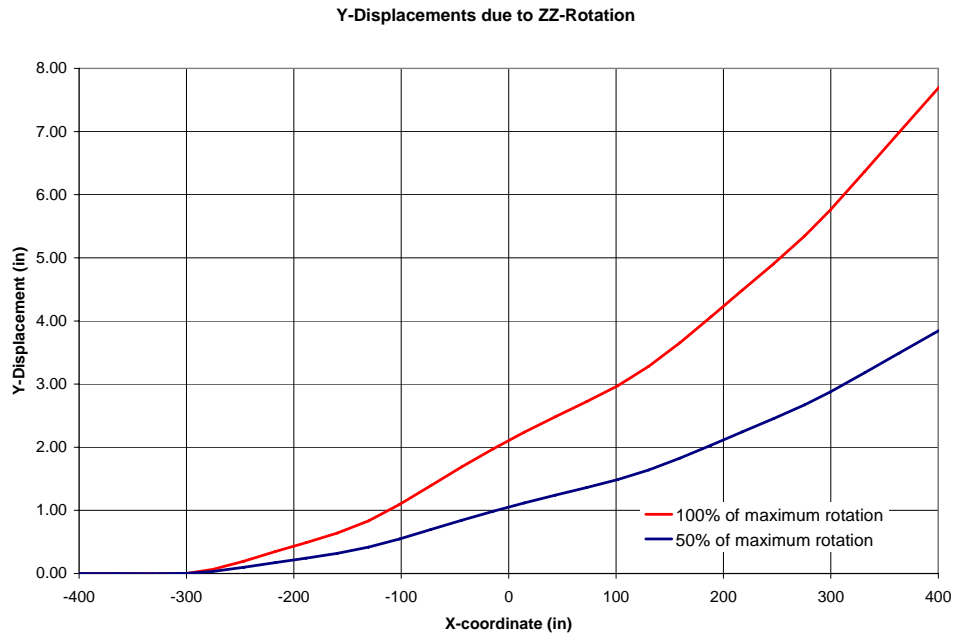


**Figure 3-17: Rail Vertical (Z) Displacements due to Joint Vertical (YY) Rotation.**

### 3.2.1.3 Case 3: Horizontal Rotation

When the floating bridge drifts laterally, it can move somewhat before being restrained by the mooring cables. This can result in a change in the horizontal angle with the transition span of up to 1.1°. The rail nodal displacements in vicinity of the joint are given for the maximum and 50% of maximum joint movements for the horizontal rotation case (Figure 3-18). As was the case for vertical rotation, rotation was postulated in [1] to cause a uniform circular curve along the track bridge structure. However, Figure 3-18 shows that the track curvature is concentrated in two locations, at either end of the track bridge. This again leads to high rail stresses in those regions, and high train car accelerations as the train passes these locations.

<b>I-90 Homer Hadley Floating Bridge – LRT Impacts</b>		<b>SC Solutions</b>
<b>Subject/Description: Expansion Joint Model</b>	Originator: Alexander Kozak	Date: 8/6/2008
	Checked: T. E. Abrahamson	Date: 8/6/2008
Disclaimer: The analysis in this technical document is preliminary and is strictly to be used as advice in determining the feasibility of placing the LRT on the Homer Hadley Floating Bridge and approach spans. It is not intended for any other purpose or as the basis for any final design or construction issue associated with this project	Calculation No.:TM-03	
	Rev No.: 0	Sheet 22 of 38



**Figure 3-18: Rail Lateral (Y) Displacements due to Joint Lateral (ZZ) Rotation.**

### 3.2.2 Combined Maximum Vertical and Lateral Rotations

Motions of the expansion joint are not expected to occur in isolation. Instead, there will generally be combinations of the relative motions. As the longitudinal displacement of the expansion joint causes no stress in the rails, that condition has been neglected here. Only the relative rotations were considered.

The expansion joint deformed model details are shown in Figure 3-19. It is noteworthy that there are two locations at each rail (at each side of the transfer beam system) where the axial force is not transmitted, providing stress relief at those locations. These points are indicated by blue squares in Figure 3-19.

Four additional analytical cases of the combined vertical (YY) and lateral (ZZ) angle change at the expansion joint were considered, as discussed in Section 3.1.3.

I-90 Homer Hadley Floating Bridge – LRT Impacts		SC Solutions
Subject/Description: <b>Expansion Joint Model</b>	Originator: Alexander Kozak	Date: 8/6/2008
	Checked: T. E. Abrahamson	Date: 8/6/2008
Disclaimer: The analysis in this technical document is preliminary and is strictly to be used as advice in determining the feasibility of placing the LRT on the Homer Hadley Floating Bridge and approach spans. It is not intended for any other purpose or as the basis for any final design or construction issue associated with this project	Calculation No.:TM-03	
	Rev No.: 0	Sheet 23 of 38

### 3.2.2.1 Case 4: Maximum Vertical and Lateral Rotations, No Wheel Loads

For the case of maximum vertical and lateral rotations, the rail axial force and bending moment about the horizontal (S) and vertical (T) axes are shown in Figure 3-20 to Figure 3-24. The axial forces are in tension in one rail and compression in the other, due to the horizontal rotation of the joint. Most of the axial force is concentrated on the fixed span side of the expansion joint. Bending moments occur mostly near the transverse guides in the track bridge, where rail motions are restricted. The moments are larger on the moving span side of the joint, resulting in higher stresses there.

Maximum vertical and lateral rotations cause significant rail normal stresses. The distribution along the rail for this case are shown in (Figure 3-25) with a maximum value of 61.7 ksi. This is compared to the rail steel yield stress 67 ksi, for an unfactored demand to capacity ratio of 0.92. The rail maximum stress is reached at the fastener located at the edge of the three-beam transition system (x = 22' 11", see Figure 3-5). Combination of the rail normal stress diagram with those of the axial force and bending moments (Figure 3-26) suggests that maximum contribution to the rail normal stress is provided by the bending moments about the horizontal and vertical axes. Although, the bending moment about the horizontal axis ( $M_s$ ) is higher than that about the vertical axis ( $M_t$ ), the section modulus about the horizontal axis ( $W_s$ ) is also much greater than that about the vertical axis ( $W_t$ ) which results in significant contribution (57%) of the expansion joint lateral rotation to the rail maximum stress:

$$\sigma = \frac{F}{A} + \frac{M_s}{W_s} + \frac{M_t}{W_t} = \frac{7.73}{0.007257} + \frac{53.54}{0.0002964} + \frac{16.83}{0.0000690} = 1,065 + 180,627 + 243,908 = 425,600 \text{ kPa} = 61.7 \text{ ksi}$$

The normal stress is calculated at the edge of the rail cross section bottom (Figure 3-27).

For other load combinations, the stress is lower, as shown in Table 3-4. For the annual event, which does not include major storms, the rail stress is only 16.1 ksi. This is only 24% of the mean yield value. Neither the load or the strength have any factors applied to them in this analysis, so the approximate D/C ratio of 0.24 for the annual event may be increased at a later date if additional load or resistance factors are applied.

Subject/Description: **Expansion Joint Model**

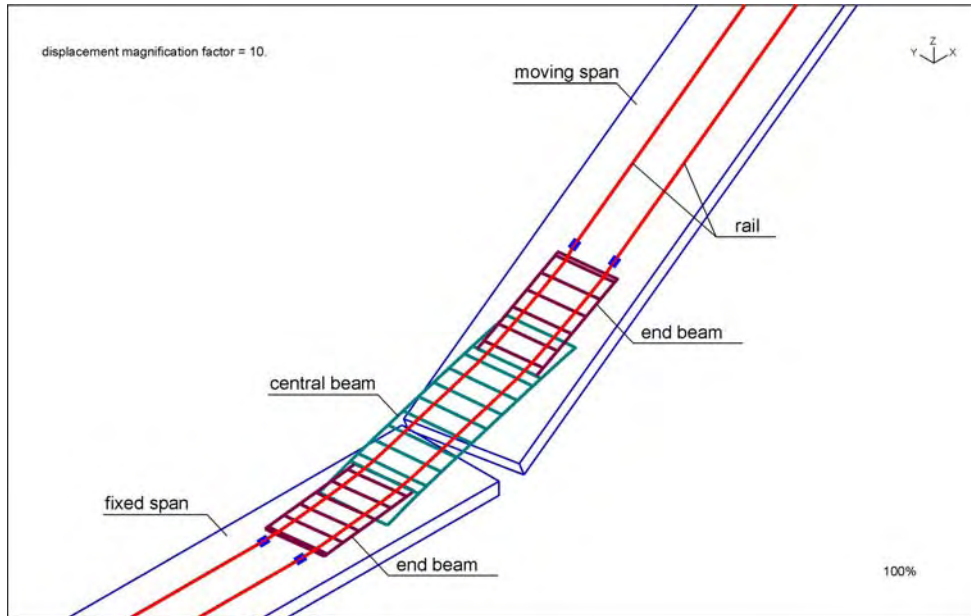
Originator: Alexander Kozak Date: 8/6/2008

Checked: T. E. Abrahamson Date: 8/6/2008

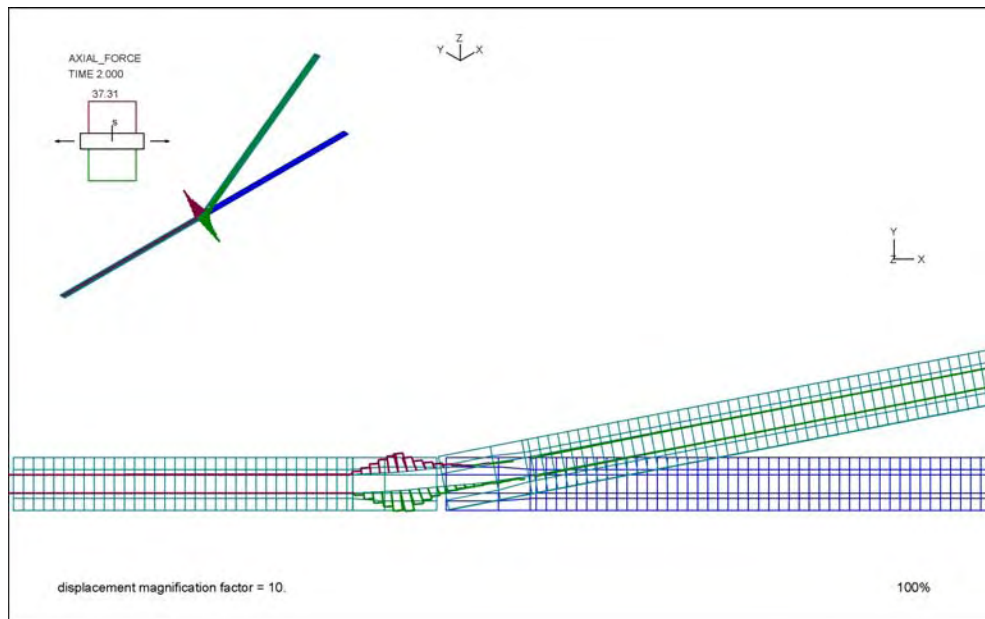
Disclaimer: The analysis in this technical document is preliminary and is strictly to be used as advice in determining the feasibility of placing the LRT on the Homer Hadley Floating Bridge and approach spans. It is not intended for any other purpose or as the basis for any final design or construction issue associated with this project

Calculation No.:TM-03

Rev No.: **0** Sheet 24 of 38



**Figure 3-19: Deformed Expansion Joint Model Details.**



**Figure 3-20: Combined Maximum Vertical (YY) and Lateral (ZZ) Rotation – Rail Axial Force on Deformed Mesh.**



Subject/Description: **Expansion Joint Model**

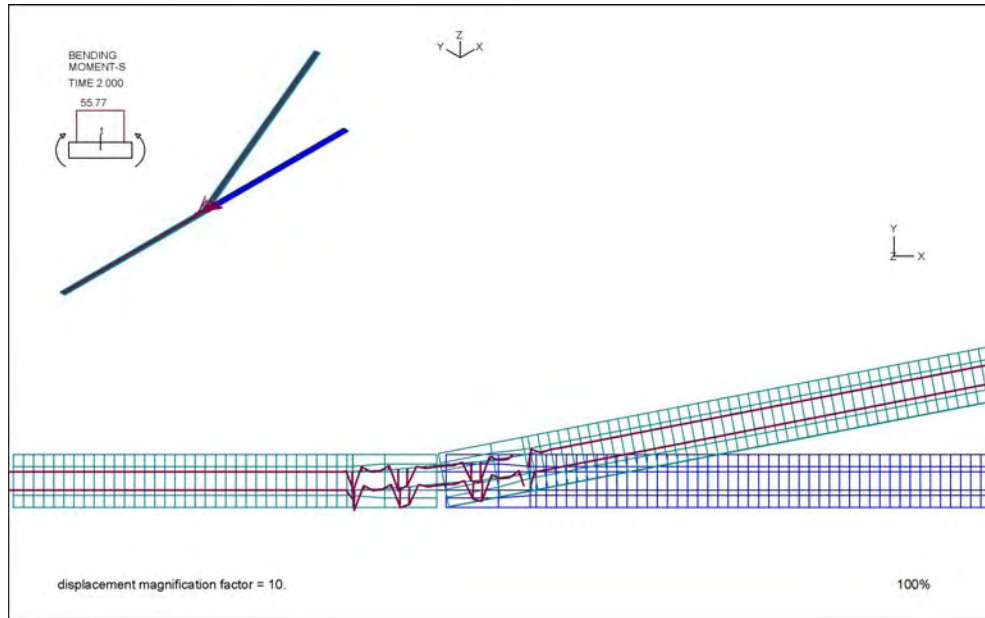
Originator: Alexander Kozak Date: 8/6/2008

Checked: T. E. Abrahamson Date: 8/6/2008

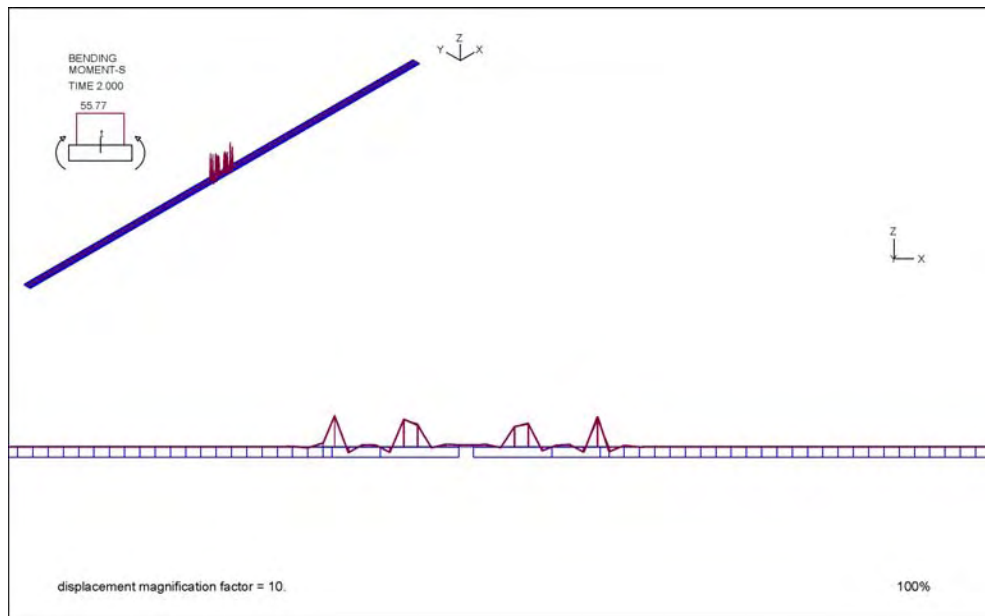
Disclaimer: The analysis in this technical document is preliminary and is strictly to be used as advice in determining the feasibility of placing the LRT on the Homer Hadley Floating Bridge and approach spans. It is not intended for any other purpose or as the basis for any final design or construction issue associated with this project

Calculation No.:TM-03

Rev No.: **0** Sheet 25 of 38



**Figure 3-21: Combined Maximum Vertical (YY) and Lateral (ZZ) Rotation – Rail Bending Moment-S (about Horizontal Axis) on Deformed Mesh.**



**Figure 3-22: Combined Maximum Vertical (YY) and Lateral (ZZ) Rotation – Rail Bending Moment-S (about Horizontal Axis) on Original Mesh.**

Subject/Description: **Expansion Joint Model**

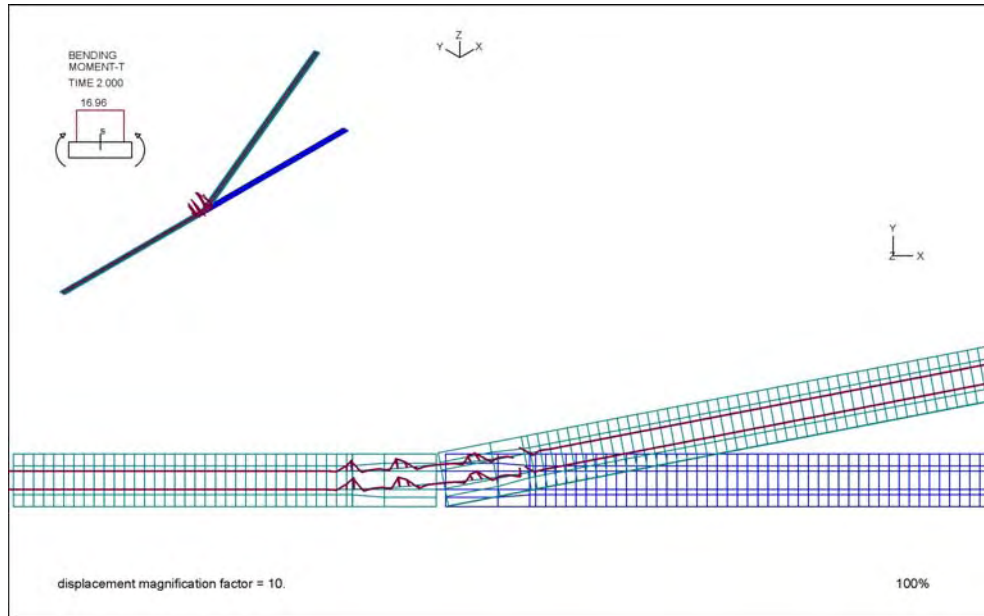
Originator: Alexander Kozak Date: 8/6/2008

Checked: T. E. Abrahamson Date: 8/6/2008

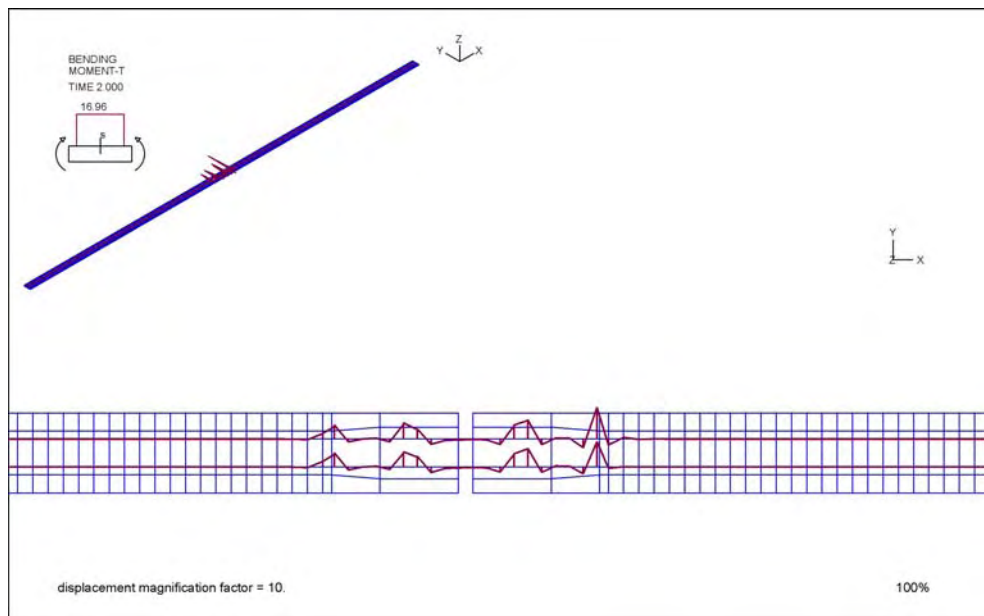
Disclaimer: The analysis in this technical document is preliminary and is strictly to be used as advice in determining the feasibility of placing the LRT on the Homer Hadley Floating Bridge and approach spans. It is not intended for any other purpose or as the basis for any final design or construction issue associated with this project

Calculation No.:TM-03

Rev No.: 0 Sheet 26 of 38



**Figure 3-23: Combined Maximum Vertical (YY) and Lateral (ZZ) Rotation – Rail Bending Moment-T (about Vertical Axis) on Deformed Mesh.**



**Figure 3-24: Combined Maximum Vertical (YY) and Lateral (ZZ) Rotation – Rail Bending Moment-T (about Vertical Axis) on Original Mesh.**

Subject/Description: **Expansion Joint Model**

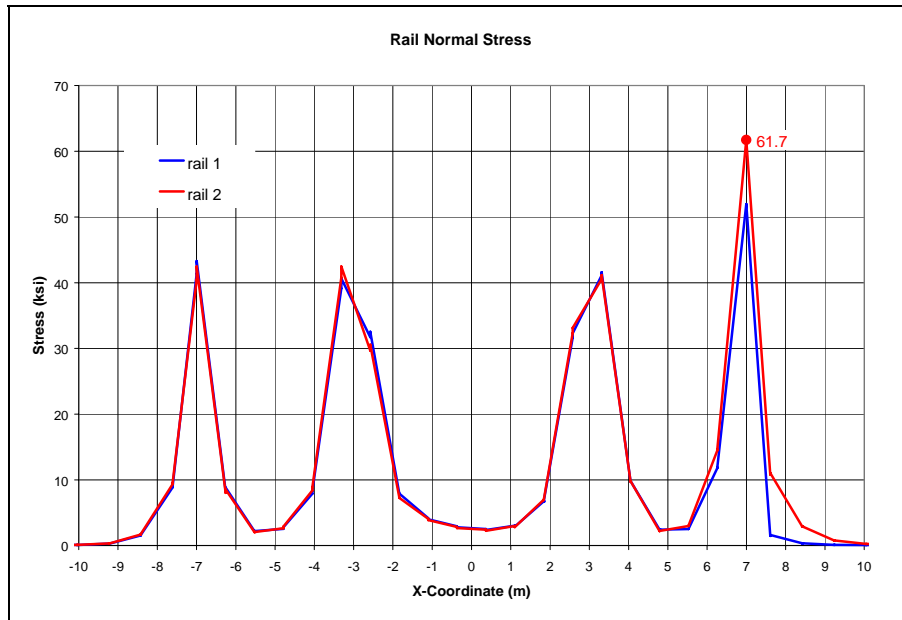
Originator: Alexander Kozak Date: 8/6/2008

Checked: T. E. Abrahamson Date: 8/6/2008

Disclaimer: The analysis in this technical document is preliminary and is strictly to be used as advice in determining the feasibility of placing the LRT on the Homer Hadley Floating Bridge and approach spans. It is not intended for any other purpose or as the basis for any final design or construction issue associated with this project

Calculation No.:TM-03

Rev No.: **0** Sheet 27 of 38



**Figure 3-25: Combined Maximum Vertical (YY) and Lateral (ZZ) Rotation – Rail Normal Stress (ksi).**

Subject/Description: **Expansion Joint Model**

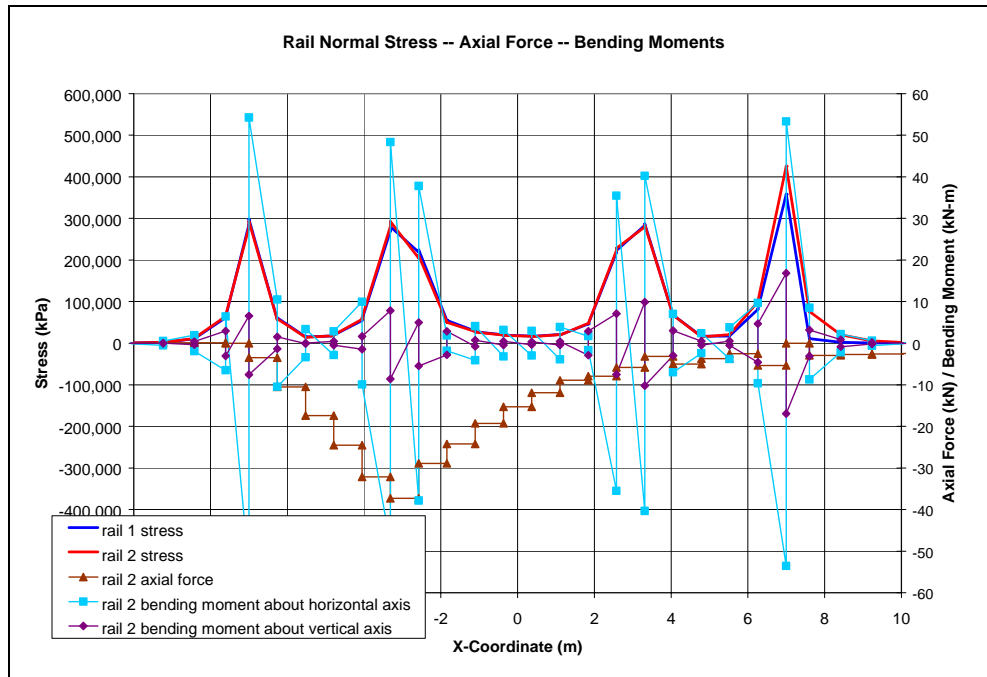
Originator: Alexander Kozak Date: 8/6/2008

Checked: T. E. Abrahamson Date: 8/6/2008

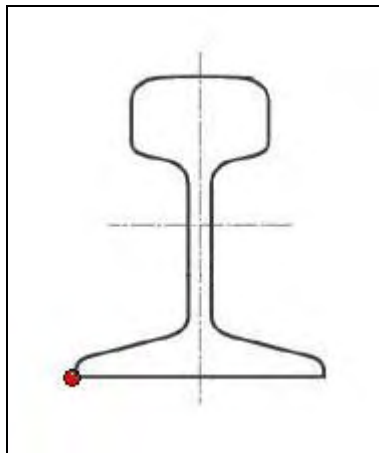
Disclaimer: The analysis in this technical document is preliminary and is strictly to be used as advice in determining the feasibility of placing the LRT on the Homer Hadley Floating Bridge and approach spans. It is not intended for any other purpose or as the basis for any final design or construction issue associated with this project

Calculation No.:TM-03

Rev No.: **0** Sheet 28 of 38



**Figure 3-26: Combined Maximum Vertical (YY) and Lateral (ZZ) Rotation – Rail Normal Stress (kPa) – Axial Force (kN) – Bending Moments (kN-m).**



**Figure 3-27: Rail Cross-Section – Point of Maximum Normal Stress**

**Table 3-4: Rail Stresses due to Expansion Joint Motion**

Case	Horizontal Angle	Vertical Angle	Rail Stress (ksi)
Annual Event	0.2°	0.4°	16.1

<b>I-90 Homer Hadley Floating Bridge – LRT Impacts</b>		<b>SC Solutions</b>
<b>Subject/Description: Expansion Joint Model</b>	Originator: Alexander Kozak	Date: 8/6/2008
	Checked: T. E. Abrahamson	Date: 8/6/2008
Disclaimer: The analysis in this technical document is preliminary and is strictly to be used as advice in determining the feasibility of placing the LRT on the Homer Hadley Floating Bridge and approach spans. It is not intended for any other purpose or as the basis for any final design or construction issue associated with this project	Calculation No.:TM-03	
	Rev No.: 0	Sheet 29 of 38

Ultimate Event	1.0°	1.25°	47.2
Combined Worst Case – Design Values	1.1°	2.2°	61.7

### 3.2.2.2 Cases 5, 6, and 7: Combined Loads at 75%, 50%, and 25%

Cases 5, 6, and 7 were run in order to provide deformed track geometry data for the vehicle dynamics model. Track stresses were not computed for these load cases. Results are not presented here.

### 3.2.2.3 Case 8: Lateral rotation and vehicle wheel reactions

A vehicle dynamics analysis is reported in [5]. The rail deformed shape (node locations of all rail nodes) was used as input for the vehicle dynamic analyses, which resulted in vehicle acceleration profiles, and wheel reactions on the rails. The rails were assumed to remain in their deformed shape computed as shown in Figure 3-18 throughout the analysis, without interaction with the wheel reactions. An evaluation of this assumption is presented in section here.

For the case of lateral (ZZ) rotation, the imposed displacements were applied to the deck models, resulting in deformations of the rails, exactly as was done above. Then the vehicle wheel reactions extracted from the vehicle dynamic analysis were applied to the rail of the expansion joint model in a transient vehicle passage analysis to estimate additional rail displacements due to the rail-vehicle interaction (Figure 3-28 and Figure 3-29). The reaction forces shown here are the total forces, and include both vertical and horizontal components. As the vertical component is much larger than the horizontal component, they show up much more clearly in Figure 3-29. The flanges on rail wheels are on the inner edge only. Therefore only the wheels on the outer side of the curve are loaded in the lateral direction. Figure 3-29 shows one wheel on the outer rail with a significant lateral load.

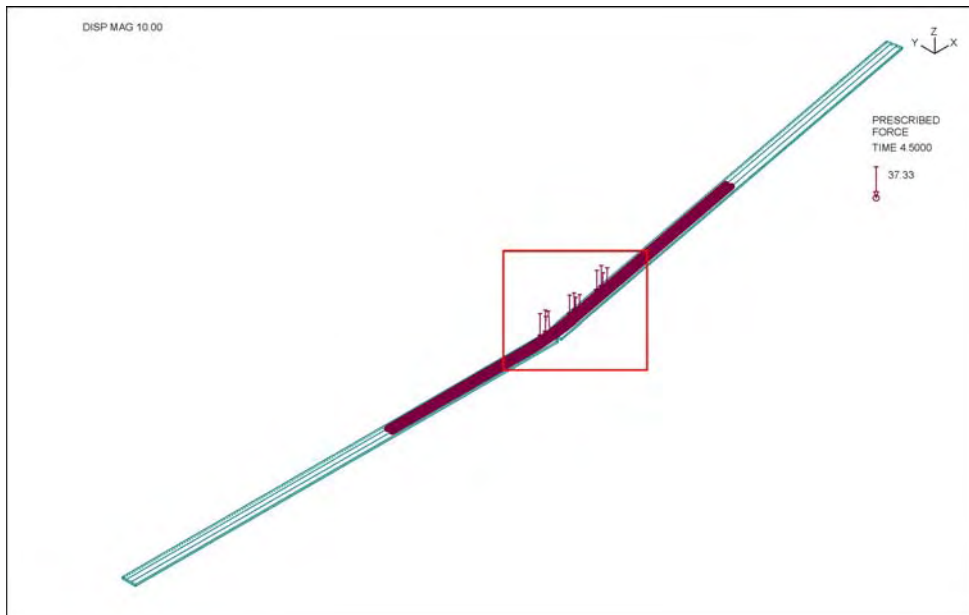
Comparison of the rail lateral (Y) displacements with those of the expansion joint model original displacements (due to the ZZ-rotation only) suggests quite negligible contribution (within  $\pm 0.07$  in.) of the wheel reactions (Figure 3-30). In the center of the track bridge, that is about a 3% error.

Rail vertical (Z) displacements are increased by 0.15 in. due to the wheel reactions (Figure 3-31). There was no significant vertical deformation due to the expansion joint

<b>I-90 Homer Hadley Floating Bridge – LRT Impacts</b>		<b>SC Solutions</b>
<b>Subject/Description: Expansion Joint Model</b>	Originator: Alexander Kozak	Date: 8/6/2008
	Checked: T. E. Abrahamson	Date: 8/6/2008
Disclaimer: The analysis in this technical document is preliminary and is strictly to be used as advice in determining the feasibility of placing the LRT on the Homer Hadley Floating Bridge and approach spans. It is not intended for any other purpose or as the basis for any final design or construction issue associated with this project	Calculation No.:TM-03	
	Rev No.: 0	Sheet 30 of 38

motion in this case, so the 0.15 in. motion dominates the original deformation. However, in the case of the vertical angle (YY rotation only), the vertical deformation was much larger (3 in. at the center of the track bridge), and the curvature causing this was concentrated in two locations. In this context, the 0.15 in. additional vertical deformation due to the weight of the train is negligible. This additional deformation is spread over the center beam part of the track bridge, with a nearly circular profile along that portion, so the curvature is relatively small.

In the horizontal direction, this indicates that the vehicle response will not be affected by rail deformations induced by the vehicle. In the vertical direction, the deformation was slightly larger, but still small compared to the track bridge deformation due to the vertical angle deformation case. Therefore, the simplified approach used in the vehicle dynamics analysis, in which the rail was assumed to remain in the rotated configurations computed in Figure 3-10 and Figure 3-11, is acceptable. A coupled vehicle dynamics model with deformable rails is not required.



**Figure 3-28: Maximum Lateral (ZZ) Rotation and Wheel Reactions.**

# I-90 Homer Hadley Floating Bridge – LRT Impacts

SC Solutions

Subject/Description: **Expansion Joint Model**

Originator: Alexander Kozak Date: 8/6/2008

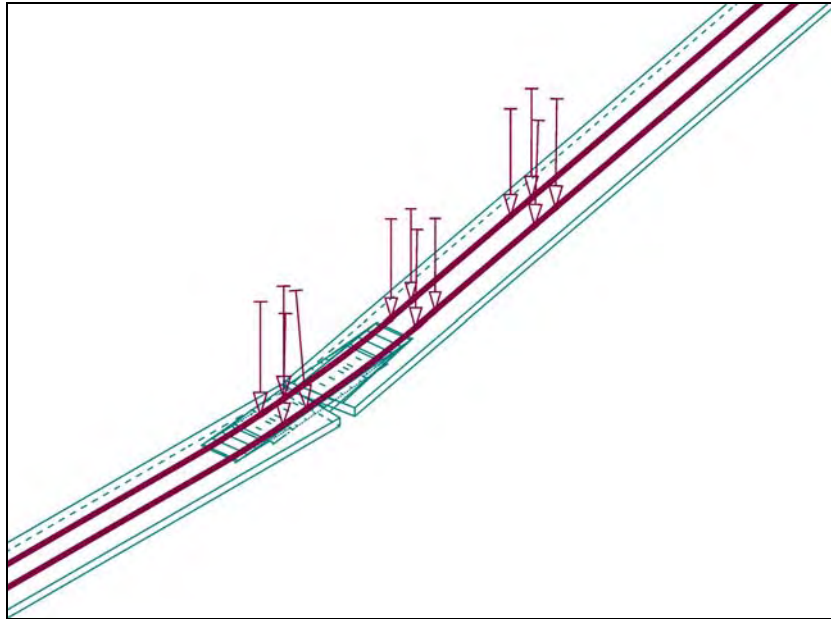
Checked: T. E. Abrahamson Date: 8/6/2008

Disclaimer: The analysis in this technical document is preliminary and is strictly to be used as advice in determining the feasibility of placing the LRT on the Homer Hadley Floating Bridge and approach spans. It is not intended for any other purpose or as the basis for any final design or construction issue associated with this project

Calculation No.:TM-03

Rev No.: **0**

Sheet 31 of 38



**Figure 3-29: Maximum Lateral (ZZ) Rotation and Wheel Reactions (zoomed).**

Subject/Description: **Expansion Joint Model**

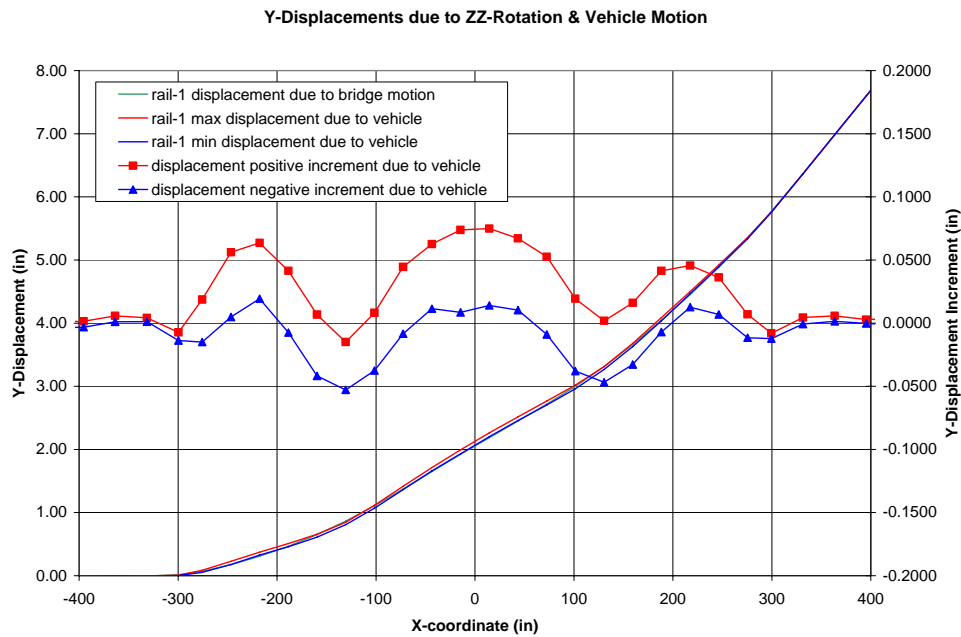
Originator: Alexander Kozak Date: 8/6/2008

Checked: T. E. Abrahamson Date: 8/6/2008

Disclaimer: The analysis in this technical document is preliminary and is strictly to be used as advice in determining the feasibility of placing the LRT on the Homer Hadley Floating Bridge and approach spans. It is not intended for any other purpose or as the basis for any final design or construction issue associated with this project

Calculation No.:TM-03

Rev No.: 0 Sheet 32 of 38



**Figure 3-30: Rail Lateral (Y) Displacements due to Joint Lateral (ZZ) Rotation and Wheel Reactions.**



<b>I-90 Homer Hadley Floating Bridge – LRT Impacts</b>		<b>SC Solutions</b>
Subject/Description: <b>Expansion Joint Model</b>	Originator: Alexander Kozak	Date: 8/6/2008
	Checked: T. E. Abrahamson	Date: 8/6/2008
Disclaimer: The analysis in this technical document is preliminary and is strictly to be used as advice in determining the feasibility of placing the LRT on the Homer Hadley Floating Bridge and approach spans. It is not intended for any other purpose or as the basis for any final design or construction issue associated with this project	Calculation No.:TM-03	
	Rev No.: <b>0</b>	Sheet 33 of 38

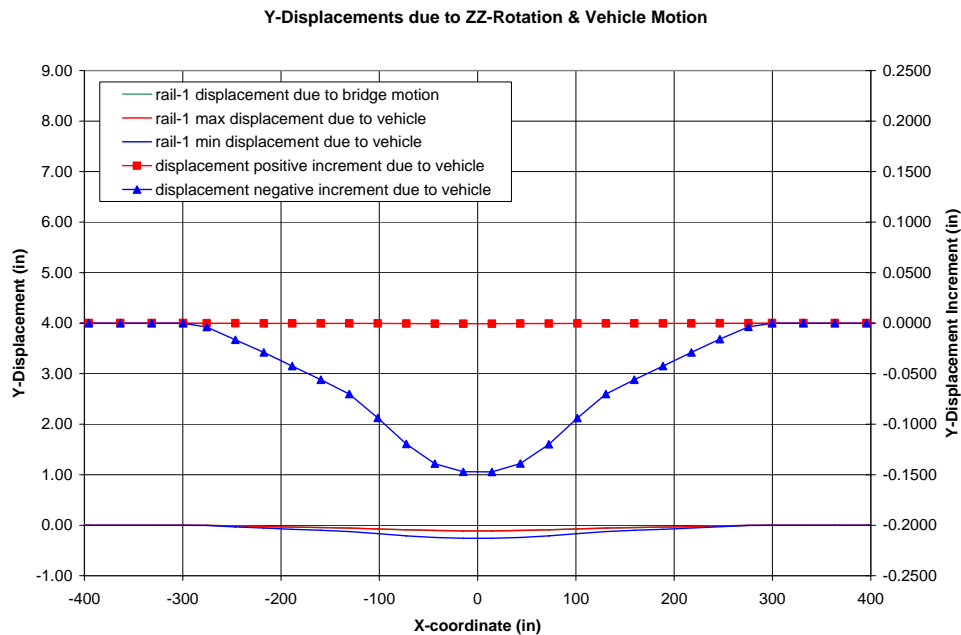


Figure 3-31: Rail Vertical (Z) Displacements due to Joint Lateral (ZZ) Rotation and Wheel Reactions.

### 3.2.2.4 Case 9: Combined maximum vertical and lateral rotation and vehicle wheel reactions

A vehicle dynamics analysis is reported in [4]. The rail deformed shape (node locations of all rail nodes) was used as input for the vehicle dynamic analyses, which resulted in vehicle acceleration profiles, and wheel reactions on the rails. The rails were assumed to remain in their deformed shape computed as shown in Figure 3-18 throughout the analysis, without interaction with the wheel reactions. An evaluation of this assumption is presented in section here.

For the case of combined vertical (YY) and lateral (ZZ) rotation, the vehicle wheel reactions extracted from the dynamic analysis were applied to the rail of the expansion joint model (together with the expansion joint YY- and ZZ-rotation) to estimate additional rail displacements due to the rail-vehicle interaction, and rail stresses.

Rail horizontal (Y) displacement increment due to the wheel reactions (Figure 3-32) is within  $\pm 0.05$  in which is less than that in case of only lateral joint rotation (compare with Figure 3-30). Rail vertical (Z) displacement increment due to the wheel reactions (Figure

<b>I-90 Homer Hadley Floating Bridge – LRT Impacts</b>		<b>SC Solutions</b>
<b>Subject/Description: Expansion Joint Model</b>	Originator: Alexander Kozak	Date: 8/6/2008
	Checked: T. E. Abrahamson	Date: 8/6/2008
Disclaimer: The analysis in this technical document is preliminary and is strictly to be used as advice in determining the feasibility of placing the LRT on the Homer Hadley Floating Bridge and approach spans. It is not intended for any other purpose or as the basis for any final design or construction issue associated with this project	Calculation No.:TM-03	
	Rev No.: 0	Sheet 34 of 38

3-33) is somewhat larger (by about 0.03 in.) than that in case of only lateral joint rotation (compare with Figure 3-31).

Maximum vertical and lateral rotations together with the vehicle wheel reactions cause rail normal stress distribution (Figure 3-34) with a maximum value of 65.9 ksi. Compare this with the maximum rail normal stress due to the joint rotation only 61.7 ksi (Figure 3-25). The rail maximum stress is reached at the fastener located at the edge of the tree-beam transition system (x = 375.5 in, see []). Contribution to the rail maximum normal stress by the axial force and bending moments is as follows:

$$\sigma = \frac{F}{A} + \frac{M_s}{W_s} + \frac{M_t}{W_t} = \frac{0}{0.007257} + \frac{55.22}{0.0002964} + \frac{18.51}{0.0000690} = 0 + 186,310 + 268,163 = 457,473 \text{ kPa} = 65.9 \text{ ksi}$$

The change in stress due to the addition of the train was only about 4 ksi. This was mostly due to a 10% increase in horizontal stresses caused by the horizontal reactions. The major contributor to the rail stresses was the expansion joint deformation, not the rail passage. For conservatism, an additional 4.2 ksi can be added to the annual and ultimate event rail stresses previously computed without the wheel loads:

Annual Event: 16.1 + 4.2 = 20.3 ksi

Ultimate Event: 47.2 + 4.2 = 51.4 ksi

Subject/Description: **Expansion Joint Model**

Originator: Alexander Kozak Date: 8/6/2008

Checked: T. E. Abrahamson Date: 8/6/2008

Disclaimer: The analysis in this technical document is preliminary and is strictly to be used as advice in determining the feasibility of placing the LRT on the Homer Hadley Floating Bridge and approach spans. It is not intended for any other purpose or as the basis for any final design or construction issue associated with this project

Calculation No.:TM-03

Rev No.: 0

Sheet 35 of 38

Y-Displacements due to YY-ZZ-Rotation & Vehicle Motion

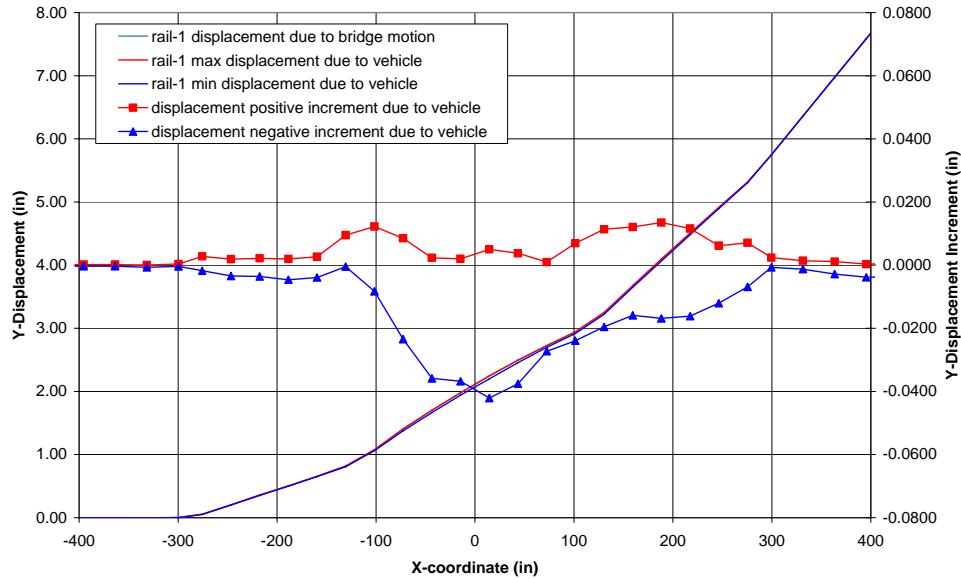


Figure 3-32: Rail Lateral (Y) Displacements due to Joint Combined Lateral (ZZ) and Vertical (YY) Rotation and Wheel Reactions.

Subject/Description: **Expansion Joint Model**

Originator: Alexander Kozak Date: 8/6/2008

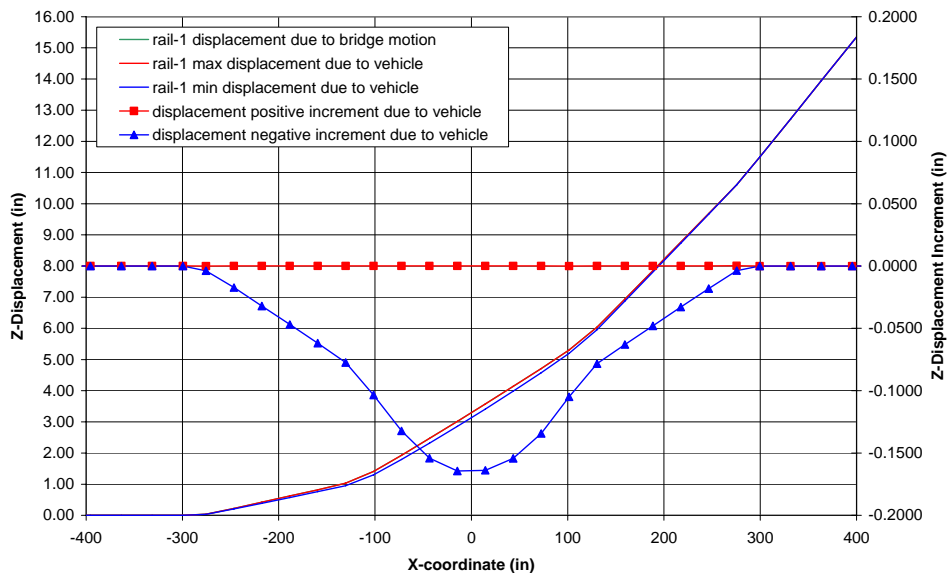
Checked: T. E. Abrahamson Date: 8/6/2008

Disclaimer: The analysis in this technical document is preliminary and is strictly to be used as advice in determining the feasibility of placing the LRT on the Homer Hadley Floating Bridge and approach spans. It is not intended for any other purpose or as the basis for any final design or construction issue associated with this project

Calculation No.:TM-03

Rev No.: **0** Sheet 36 of 38

Z-Displacements due to YY-ZZ-Rotation & Vehicle Motion



**Figure 3-33: Rail Vertical (Z) Displacements due to Joint Combined Lateral (ZZ) and Vertical (YY) Rotation and Wheel Reactions.**

Subject/Description: **Expansion Joint Model**

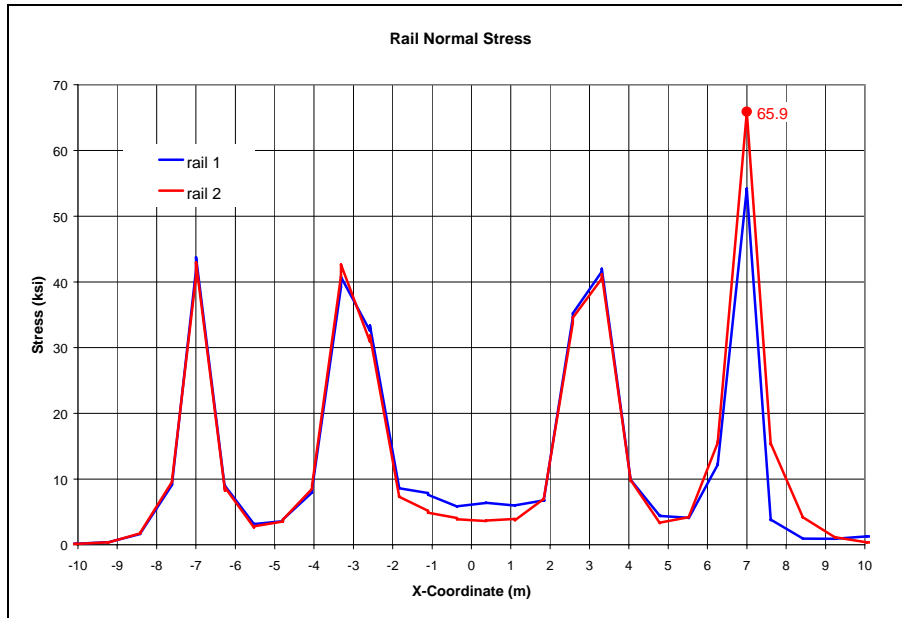
Originator: Alexander Kozak Date: 8/6/2008

Checked: T. E. Abrahamson Date: 8/6/2008

Disclaimer: The analysis in this technical document is preliminary and is strictly to be used as advice in determining the feasibility of placing the LRT on the Homer Hadley Floating Bridge and approach spans. It is not intended for any other purpose or as the basis for any final design or construction issue associated with this project

Calculation No.:TM-03

Rev No.: **0** Sheet 37 of 38



**Figure 3-34: Combined Maximum Vertical (YY) and Lateral (ZZ) Rotation – Rail Normal Stress Envelope (ksi).**

<b>I-90 Homer Hadley Floating Bridge – LRT Impacts</b>		<b>SC Solutions</b>
<b>Subject/Description: Expansion Joint Model</b>	Originator: Alexander Kozak	Date: 8/6/2008
	Checked: T. E. Abrahamson	Date: 8/6/2008
Disclaimer: The analysis in this technical document is preliminary and is strictly to be used as advice in determining the feasibility of placing the LRT on the Homer Hadley Floating Bridge and approach spans. It is not intended for any other purpose or as the basis for any final design or construction issue associated with this project	Calculation No.:TM-03	
	Rev No.: 0	Sheet 38 of 38

#### 4. Conclusions

Rail stresses can be very large if the worst case design rotations in the horizontal and vertical directions are directly combined. However, this is a much larger deformation than realistically expected. If the “ultimate event” is used to define the joint rotations, then the stress is about 47 ksi, while “annual event” stresses are about 16 ksi, both without any train live loads. Adding the train live load increases the rail stress by about 4 ksi. The train will not run during extreme storms, as are part of the definition of the ultimate event. Therefore, only the annual event should have the live load added to it. This results in a rail stress of about 20 ksi, compared to a strength of 67 ksi.

Dynamic wheel loads from the vehicle dynamics analysis were applied to the deformed rail system, to determine the extent of the rail deformations due to the vehicle loads. The rail deformations were very small compared to the deformations due to the expansion joint rotations. The difference would have a negligible effect on the behavior of the vehicle. Therefore, a dynamic coupled rail / vehicle analysis was not required. The deformed shape of the rail was fixed in the vehicle dynamics analysis, with no additional deformation due to the vehicle loads.

**I-90 Homer Hadley Floating Bridge – LRT Impacts  
TECHNICAL MEMORANDUM COVER SHEET**

**Technical Memorandum TM-04  
Vehicle Dynamics Analysis**

**Prepared by: SC Solutions**  
**Date: August 6, 2008**

**Disclaimer:**

The analysis in this technical document is preliminary and is strictly to be used as advice in determining the feasibility of placing the LRT on the Homer Hadley Floating Bridge and approach spans. It is not intended for any other purpose or as the basis for any final design or construction issue associated with this project.

<b>I-90 Homer Hadley Floating Bridge – LRT Impacts</b>		<b>SC Solutions</b>
<b>Subject/Description: Vehicle Dynamics Analysis</b>	Originator: T. E. Abrahamson	Date: 8/6/2008
	Checked: J Kleyn, A. Kozak	Date: 8/6/2008
Disclaimer: The analysis in this technical document is preliminary and is strictly to be used as advice in determining the feasibility of placing the LRT on the Homer Hadley Floating Bridge and approach spans. It is not intended for any other purpose or as the basis for any final design or construction issue associated with this project	Calculation No.:TM-04	
	Rev No.: 0	Sheet 2 of 25

1. Introduction.....	3
2. Basis for Analysis and References.....	3
3. Discussion.....	4
3.1 Model Description .....	4
3.1.1 Geometry.....	4
3.1.2 Boundary Conditions .....	12
3.1.3 Loading .....	12
3.2 Analysis Results.....	13
3.2.1 Track Loads .....	13
3.2.2 Train Accelerations .....	14
4. Conclusions.....	24



<b>I-90 Homer Hadley Floating Bridge – LRT Impacts</b>		<b>SC Solutions</b>
<b>Subject/Description: Vehicle Dynamics Analysis</b>	Originator: T. E. Abrahamson	Date: 8/6/2008
	Checked: J Kleyn, A. Kozak	Date: 8/6/2008
Disclaimer: The analysis in this technical document is preliminary and is strictly to be used as advice in determining the feasibility of placing the LRT on the Homer Hadley Floating Bridge and approach spans. It is not intended for any other purpose or as the basis for any final design or construction issue associated with this project	Calculation No.:TM-04	
	Rev No.: 0	Sheet 3 of 25

## 1. Introduction

The Homer Hadley Floating Bridge has expansion joints at the connections between the transition spans and the floating spans. These accommodate the motions of the floating sections relative to the fixed sections on the land. The floating sections will change elevations as the water level changes, and will move horizontally during storms.

The analysis was conducted with preliminary data, not final data on the design of the expansion joint three beam track bridge. In addition, the actual design load conditions were not fully defined. Also, the dynamic data for the rail vehicles may not be final. Therefore, this should be considered to be a preliminary study, which should not be used for final design. This memo is provided to convey the results of this study.

As the vehicle passes the expansion joints, the path of the wheels follows the rails, which will be deformed by the expansion joint rotation. This causes acceleration loads on the train cars and passengers. These accelerations must meet guidelines for passenger comfort.

In this analysis, a vehicle dynamics model of a three car train was generated, and analyzed in a dynamic analysis of the vehicle passing over the expansion joint. The result was a time history of the accelerations of the train cars. These were compared to the acceleration limits, to define the speed limit for the train.

## 2. Basis for Analysis and References

1. Sound Transit East Link Project Team. "Eastside HCT Corridor. I-90 Floating Bridge (Homer Hadley). Expansion Joint. Final Conceptual Report". January, 2008.
2. ADINA v. 8.4, ADINA R&D, Inc, 2007
3. SoundTransit Link Design Criteria, 2005
4. ISO 2631, Testing and Extrapolation Methods, High Speed Marine Vehicles, Excerpt of ISO-2631, 1999
5. Sound Transit, Car Body Roll Control Method, ER 2013, CDRL 11-6, Kinkisharyo International, LLC.
6. Expansion Joint Analysis

Much of the data regarding the track bridge was defined in [1]. The loads were also summarized in this reference. The design criteria are defined in [3]. All analysis was

<b>I-90 Homer Hadley Floating Bridge – LRT Impacts</b>		<b>SC Solutions</b>
<b>Subject/Description: Vehicle Dynamics Analysis</b>	Originator: T. E. Abrahamson	Date: 8/6/2008
	Checked: J Kleyn, A. Kozak	Date: 8/6/2008
Disclaimer: The analysis in this technical document is preliminary and is strictly to be used as advice in determining the feasibility of placing the LRT on the Homer Hadley Floating Bridge and approach spans. It is not intended for any other purpose or as the basis for any final design or construction issue associated with this project	Calculation No.:TM-04	
	Rev No.: 0	Sheet 4 of 25

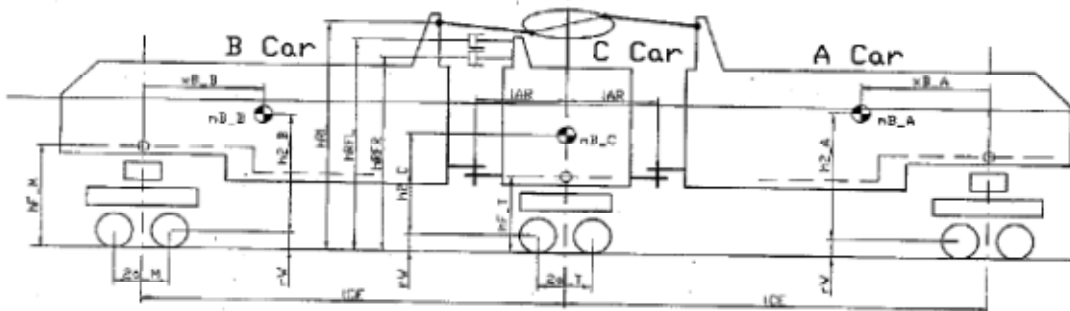
performed using ADINA v. 8.4 [2]. Acceleration limits for passenger comfort were derived from [4]. Dynamic characteristics were found in [5]. The deformed rail geometry was provided by the Expansion Joint Analysis [6].

### 3. Discussion

#### 3.1 Model Description

##### 3.1.1 Geometry

The Light Rail Vehicle (LRV) consists of 3 trucks supporting an articulated vehicle (Figure 3-1). The vehicle is separated into 3 cars, A, B, and C. The trucks at cars A and B are motorized, while the truck at car C is a trailer truck.



**Figure 3-1: Light Rail Vehicle**

A model of the LRV was developed based on the data found in the “Car Body Roll Control Method” report. This included the mass, stiffness, and damping of the vehicle and suspension system. The schematic of the trucks is shown in Figure 3-2. The data that accompanies the schematic was regenerated in an excel file, which is shown in Table 3-1. The values and units in the original were difficult to read, but they were interpreted to the best of our ability.

The model plot is shown in Figure 3-3. It extends from the axle, through springs to the truck frame, up through the bolster in Trucks A and B, and on to the car body. Cars B and C are connected with dampers, but not Cars A and C. The train travels in the direction of Truck A.

<b>I-90 Homer Hadley Floating Bridge – LRT Impacts</b>		<b>SC Solutions</b>
<b>Subject/Description: Vehicle Dynamics Analysis</b>	Originator: T. E. Abrahamson	Date: 8/6/2008
	Checked: J Kleyn, A. Kozak	Date: 8/6/2008
Disclaimer: The analysis in this technical document is preliminary and is strictly to be used as advice in determining the feasibility of placing the LRT on the Homer Hadley Floating Bridge and approach spans. It is not intended for any other purpose or as the basis for any final design or construction issue associated with this project	Calculation No.:TM-04	
	Rev No.: 0	Sheet 5 of 25

Details of the assembly of a Truck B are shown in Figure 3-4. The axles are at the lowest point in the model, with an elevation of 0.2m. Translational springs in 3 directions connect the axles to the truck frame. The rotations across these suspension springs are also constrained for stability. The truck frame is considered rigid, so it was modeled as 4 rigid beam elements connected at the center. A 6 DOF spring connected the center of the truck to the bolster. The bolster was then connected to the car floor node. The lateral translations and rotations in this connection are considered rigid, so the DOF's were constrained to be equal. The vertical and torsional displacements are somewhat flexible, as defined in Table 3-1 (the truck is allowed to rotate with respect to the car as the vehicle goes around a corner). Each node in Figure 3-3 has a mass defined in Table 3-1.

A wider view of Car B is shown in Figure 3-5. A rigid beam extends from the connection between the bolster and the car floor to the center of mass of the car. The car mass is located at this point. All acceleration data for Car B is extracted at this point.

The construction of Car A is identical to Car B, except that some of the values of mass and stiffness are different.

Figure 3-6 shows the detail view of Car C. The truck is similar to Car B, but the bolster is integrated into the car so there is no separate bolster mass. Car C is connected to Car A and Car B at links that transmit translational forces, but not rotational moments. At the top of Car C, there are 2 dampers at the outer edges of the car connecting to Car B only. These were modeled as a single damper with longitudinal and vertical torsional damping. There is negligible static stiffness in this connection. The ends of the dampers are connected by rigid beams to the Car B and Car C center of masses. There is also a small mass at the damper location, related to the overhead electrical system. The Car A to Car C does not have the dampers, but does have a mass point for the electrical system. There is no connection to Car C at the top of Car A.

Subject/Description: **Vehicle Dynamics Analysis**

Originator: T. E. Abrahamson

Date: 8/6/2008

Checked: J Kleyn, A. Kozak

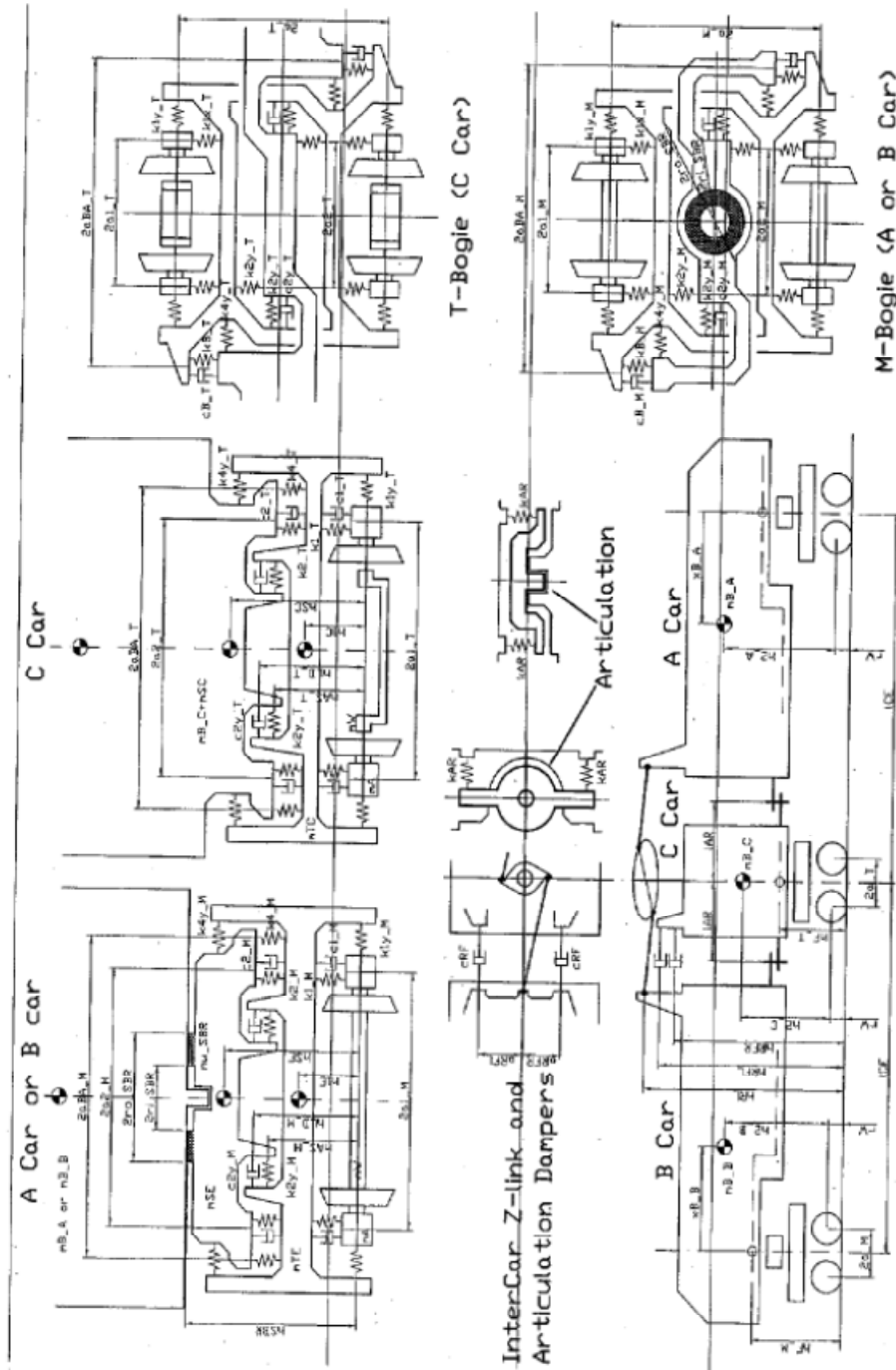
Date: 8/6/2008

Disclaimer: The analysis in this technical document is preliminary and is strictly to be used as advice in determining the feasibility of placing the LRT on the Homer Hadley Floating Bridge and approach spans. It is not intended for any other purpose or as the basis for any final design or construction issue associated with this project

Calculation No.: TM-04

Rev No.: 0

Sheet 6 of 25



<b>I-90 Homer Hadley Floating Bridge – LRT Impacts</b>		<b>SC Solutions</b>
<b>Subject/Description: Vehicle Dynamics Analysis</b>	Originator: T. E. Abrahamson	Date: 8/6/2008
	Checked: J Kleyn, A. Kozak	Date: 8/6/2008
Disclaimer: The analysis in this technical document is preliminary and is strictly to be used as advice in determining the feasibility of placing the LRT on the Homer Hadley Floating Bridge and approach spans. It is not intended for any other purpose or as the basis for any final design or construction issue associated with this project	Calculation No.:TM-04	
	Rev No.: <b>0</b>	Sheet 7 of 25

**Figure 3-2: LRV Truck Schematic**

Subject/Description: **Vehicle Dynamics Model**

Originator:

Date:

Checked:

Date:

Disclaimer: The analysis in this technical document is preliminary and is strictly to be used as advice in determining the feasibility of placing the LRT on the Homer Hadley Floating Bridge and approach spans. It is not intended for any other purpose or as the basis for any final design or construction issue associated with this project.

Calculation No.:

Rev No.: **0**

Sheet 8 of 25

**Table 3-1: Truck Model Parameters**

Category	Part	Unit	Variable Name			AW0			AW1			AW2			AW3			
			A	B	C	A	B	C	A	B	C	A	B	C	A	B	C	
Mass	Car Body Mass	kg/body	mB_A	mB_B	mB_C	13499	14374	3777	15739	16684	4477	19659	20604	5037	21689	22634	5177	
	Bolster Mass	kg/bogie	mSE	mSE	mSC	570	570	300	570	570	300	570	570	300	570	570	300	
	Bogie Spring Mass	kg/bogie	mTE	mTE	mTC	4095	4095	1215	4095	4095	1215	4095	4095	1215	4095	4095	1215	
	Bogie Unsprung Mass	kg/axle	mW	mW	mW	1955	1955	2635	1955	1955	2635	1955	1955	2635	1955	1955	2635	
	Axle Box Mass	kg/box	mA	mA	mA	50	50	115	50	50	115	50	50	115	50	50	115	
	Bolster Anchor Mass	kg/rod	mBAM	mBAM	mBAT	12	12	9.5	12	12	9.5	12	12	9.5	12	12	9.5	
	Articulation Arm Mass	kg/body	mAP	mAP	-	50	50		50	50		50	50		50	50		
	Articulation Bearing Mass	kg/body	mAR	mAR	-	30	30		30	30		30	30		30	30		
	InterCar Z-link Mass	kg/rod	mRL	mRL	mRB	30	30	50	30	30	50	30	30	50	30	30	50	
Inertia	Moment of Inertia, Car Body	Roll	k-m^2	IXBA	IXBB	IXBC	31600	33648	10787	36843	39056	12787	46020	48232	14386	50772	52984	14786
		Pitch	k-m^2	IYBA	IYBB	IYBC	173976	185253	6884	202846	215025	8159	253367	265546	9180	279530	291709	9435
		Yaw	k-m^2	IZBA	IZBB	IZBC	173976	185253	6884	202846	215025	8159	253367	265546	9180	279530	291709	9435
	Moment of Inertia, Bogie Sprung Mass	Roll	k-m^2	iXTE	iXTE	iXTC	1481	1481	1199	1481	1481	1199	1481	1481	1199	1481	1481	1199
		Pitch	k-m^2	iYTE	iYTE	lyTC	2184	2184	1767	2184	2184	1767	2184	2184	1767	2184	2184	1767
		Yaw	k-m^2	iZTE	iZTE	iZTC	3023	3023	2446	3023	3023	2446	3023	3023	2446	3023	3023	2446
Stiffness	Stiffness, Axle Box Guide	Vertical	N/mm/axle	k1_M	k1_M	k1_T	2430	2430	2650	2430	2430	2650	2430	2430	2650	2610	2610	2710
		Longitudinal	N/mm/axle	k1x_M	k1x_M	k1_x_T	32000	32000	32000	34320	34320	36280	37270	37270	41190	38250	38250	44130
		Lateral	N/mm/axle	k1y_M	k1y_M	k1y_T	4400	4400	4200	4610	4610	4510	4710	4710	4610	4810	4810	4710
	Stiffness, Bolset Spring	Vertical	N/mm/half bogie	k2_A	k2_B	k2_C	393	406	425	452	467	486	527	544	620	570	583	682
		Longitudinal	N/mm/half bogie	k2y_A	k2y_B	k2y_C	267	271	279	291	297	305	323	329	357	339	344	377
		Lateral	N/mm/half bogie	k2y_A	k2y_B	k2y_C	267	271	279	291	297	305	323	329	357	339	344	377
	Stiffness, Bolster Anchor	Vertical	N/mm/half bogie	k4_M	k4_M	k4_T	13700	13700	17000	13700	13700	17000	13700	13700	17000	13700	13700	17000
		Lateral	N/mm/half bogie	k4y_M	k4y_M	k4y_T	1610	1610	1650	1610	1610	1650	1610	1610	1650	1610	1610	1650
		Longitudinal	N/mm/half bogie	kB_M	kB_M	kB_T	13700	13700	17000	13700	13700	17000	13700	13700	17000	13700	13700	17000
	Stiffness, Articulation Rubber Bushing		N/m	kAR	kAR	kAR	115718470			115718470			115718470			115718470		
	Damping	Axle Spring Damping	N-s/mm/bogie	c1_M	c1_M	c1_T	2.5	2.5	2.6	2.5	2.5	2.6	2.5	2.5	2.6	2.5	2.5	2.6
		Bolster Spring Damping	N-s/mm/bogie	c2_A	c2_B	c2_C	104.6	108.2	113.4	121.4	125.4	133.1	143.1	147.9	169.1	155.1	158.7	187.2
Lateral Damper		N-s/mm/bogie	c2y_M	c2y_M	c2y_T	63.5	63.5	63.5	63.5	63.5	63.5	63.5	63.5	63.5	63.5	63.5	63.5	
Articulation Damper		N-s/m	-	cRF	cRF		588000	588000		588000	588000		588000	588000		588000	588000	
Vertical Dimension	Wheel Radius	m	rW			0.33	0.33	0.33	0.33	0.33	0.33	0.33	0.33	0.33	0.33	0.33	0.33	
	Height of Center of Gravity of Car Body from Axle	m	h2_a	h2_B	h2_C	1.51	1.51	1.275	1.432	1.435	1.183	1.369	1.374	1.167	1.347	1.353	1.164	

I-90 Homer Hadley Floating Bridge – LRT Feasibility Studies

SC Solutions

Subject/Description: **Vehicle Dynamics Model**

Originator:

Date:

Checked:

Date:

Disclaimer: The analysis in this technical document is preliminary and is strictly to be used as advice in determining the feasibility of placing the LRT on the Homer Hadley Floating Bridge and approach spans. It is not intended for any other purpose or as the basis for any final design or construction issue associated with this project.

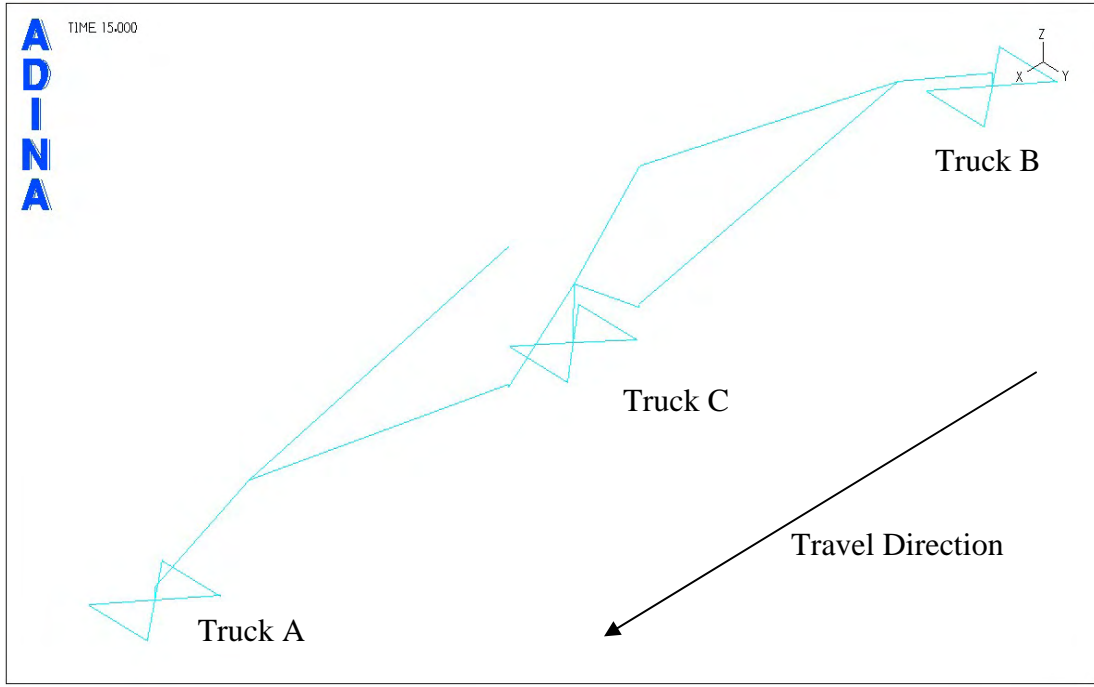
Calculation No.:

Rev No.: **0**

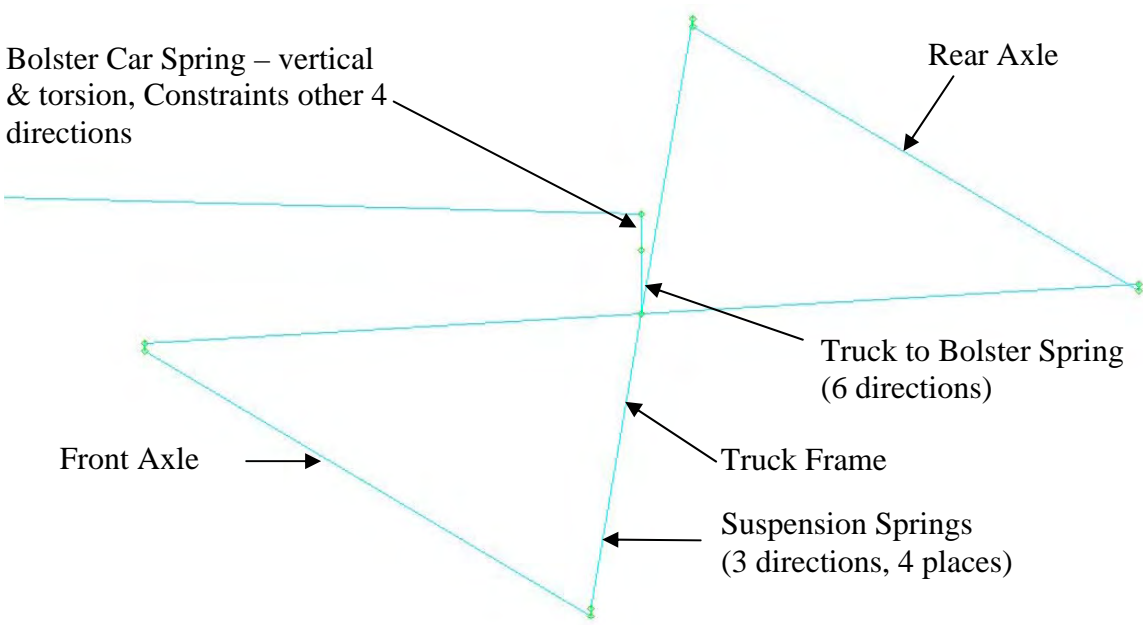
Sheet 9 of 25

Category	Part	Unit	Variable Name			AW0			AW1			AW2			AW3			
			A	B	C	A	B	C	A	B	C	A	B	C	A	B	C	
	Height of Floor of Car Body from Rail	m	hF_M	hF_M	hF_T	0.89	0.89	0.35	0.89	0.89	0.35	0.89	0.89	0.35	0.89	0.89	0.35	
	Height of Center of Gravity of Bolster from Axle	m	hSE	hSE	hSC	0.23	0.23	0.247	0.23	0.23	0.247	0.23	0.23	0.247	0.23	0.23	0.247	
	Height of Side Bearing of Bogie from Axle	m	hSBR	hSBR	-	0.37	0.37		0.37	0.37		0.37	0.37		0.37	0.37		
	Height of Inter Car Z-Link from Rail	m	hRL			3.2505	3.2505	3.2505	3.2505	3.2505	3.2505	3.2505	3.2505	3.2505	3.2505	3.2505	3.2505	3.2505
	Height of Articulation Damper from Rail	Right	m	-	hRFR		3.252	3.252		3.252	3.252		3.252	3.252		3.252	3.252	
		Left	m	-	hRFL		3.241	3.241		3.241	3.241		3.241	3.241		3.241	3.241	
	Height of Center of Gravity of Bogie Sprung Mass from Axle	m	h1E	h1E	h1C	0.05	0.05	0.05	0.05	0.05	0.05	0.05	0.05	0.05	0.05	0.05	0.05	0.05
	Height of Bolster Spring from Axle	m	hAS_M	hAS_M	hAS_T	0.23	0.23	0.247	0.23	0.23	0.247	0.23	0.23	0.247	0.23	0.23	0.247	0.23
Height of Lateral Damper form Axle	m	hLD_M	hLD_M	hLD_T	0.29	0.29	0.11	0.29	0.29	0.11	0.29	0.29	0.11	0.29	0.29	0.11	0.29	
Longitudinal Dimension	Initial Position of Center Bogie	m			xC			15			15			15			15	
	Distance between Bogie Centers	m	ICE	ICE	ICE	10.922	10.922	10.922	10.922	10.922	10.922	10.922	10.922	10.922	10.922	10.922	10.922	
	Distance from Articulation to Center Bogie	m	IAR	IAR	IAR	1.7	1.7	1.7	1.7	1.7	1.7	1.7	1.7	1.7	1.7	1.7	1.7	
	Half of Wheel Base	m	a_M	a_M	a_T	0.95	0.95	0.9	0.95	0.95	0.9	0.95	0.95	0.9	0.95	0.95	0.9	
	Longitudinal offset to CG of Carbody from Bogie Center	m	xB_A	xB_B	-	2.45	2.45		2.45	2.45		2.45	2.45		2.45	2.45		
	Length of Bolster Anchor	m	I4_M	I4_M	I4_T	0.65	0.65	0.45	0.65	0.65	0.45	0.65	0.65	0.45	0.65	0.65	0.45	
Lateral Dimension	Half of Lateral Distance across Axle Springs	m	a1_M	a1_M	a1_T	0.575	0.575	0.5985	0.575	0.575	0.5985	0.575	0.575	0.5985	0.575	0.575	0.5985	
	Half of Lateral distance across Bolster Springs	m	a2_M	a2_M	a2_T	0.92	0.92	0.9	0.92	0.92	0.9	0.92	0.92	0.9	0.92	0.92	0.9	
	Half of Lateral Distance across Boletsr Anchors	m	aBA_M	aBA_M	aBA_T	1.16	1.16	1.05	1.16	1.16	1.05	1.16	1.16	1.05	1.16	1.16	1.05	
	Lateral Offset of Lateral Damper	on Bolster	m	aLDB_M	aLDB_M	aLDB_F	1.12	1.12	0.9457	1.12	1.12	0.9457	1.12	1.12	0.9457	1.12	1.12	0.9457
		on Frame	m	aLDT_M	aLDT_M	aLDT_F	0.777	0.777	0.7355	0.777	0.777	0.7355	0.777	0.777	0.7355	0.777	0.777	0.7355
	Lateral Offset of Articulation Damper	Right	m			aRFR			0.45			0.45			0.45			0.45
Left		m			aRFL			0.615			0.615			0.615			0.615	
Others	Coefficient of Friction, Side Bearing	m	mu_SBR	mu_SBR		0.45	0.45		0.45	0.45		0.45	0.45		0.45	0.45		
	Outside Ratus, Side Bearing	m	ro_SBR	ro_SBR		0.25	0.25		0.25	0.25		0.25	0.25		0.25	0.25		
	Inside Ratus, Side Bearing	m	ri_SBR	ri_SBR		0	0		0	0		0	0		0	0		
	Clearance of Lateral Bumpstop	m	eLS_M	eLS_M	eLS_T	0.01	0.01	0.026	0.01	0.01	0.026	0.01	0.01	0.026	0.01	0.01	0.026	

I-90 Homer Hadley Floating Bridge – LRT Impacts		SC Solutions
Subject/Description: <b>Vehicle Dynamics Analysis</b>	Originator: T. E. Abrahamson	Date:
Disclaimer: The analysis in this technical document is preliminary and is strictly to be used as advice in determining the feasibility of placing the LRT on the Homer Hadley Floating Bridge and approach spans. It is not intended for any other purpose or as the basis for any final design or construction issue associated with this project.	Checked: A. Kozak	Date:
	Rev No.: 0	Sheet 10 of 25



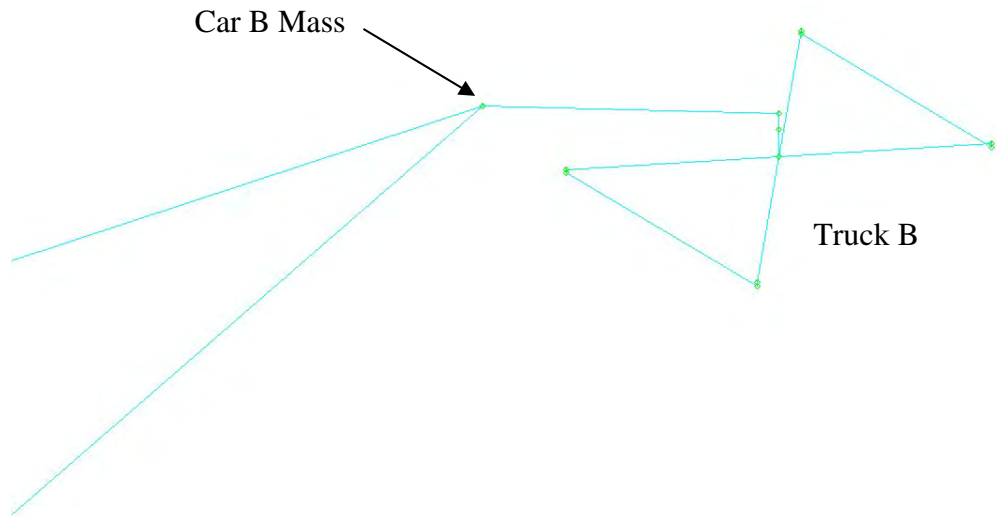
**Figure 3-3: Vehicle Dynamics Model**



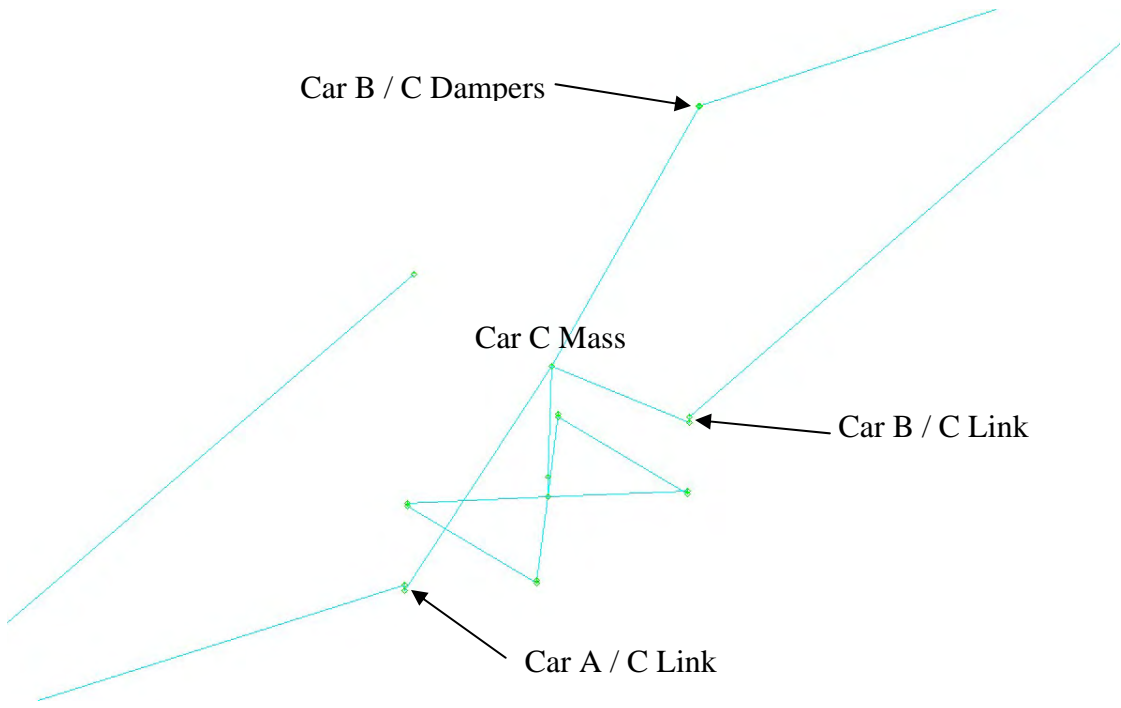
**Figure 3-4: Truck B Detail**



I-90 Homer Hadley Floating Bridge – LRT Impacts		SC Solutions
Subject/Description: <b>Vehicle Dynamics Analysis</b>	Originator: T. E. Abrahamson	Date:
Disclaimer: The analysis in this technical document is preliminary and is strictly to be used as advice in determining the feasibility of placing the LRT on the Homer Hadley Floating Bridge and approach spans. It is not intended for any other purpose or as the basis for any final design or construction issue associated with this project.	Checked: A. Kozak	Date:
	Rev No.: 0	Sheet 11 of 25



**Figure 3-5: Car B Detail**



**Figure 3-6: Car C Detail**

I-90 Homer Hadley Floating Bridge – LRT Impacts		SC Solutions
Subject/Description: <b>Vehicle Dynamics Analysis</b>	Originator: T. E. Abrahamson	Date:
Disclaimer: The analysis in this technical document is preliminary and is strictly to be used as advice in determining the feasibility of placing the LRT on the Homer Hadley Floating Bridge and approach spans. It is not intended for any other purpose or as the basis for any final design or construction issue associated with this project.	Checked: A. Kozak	Date:
	Rev No.: 0	Sheet 12 of 25

### 3.1.2 Boundary Conditions

This is a transient dynamic model, in which the entire model moves. The only boundary conditions are the applied displacements, which constrain the wheels to follow the path defined by the rails. These are applied dynamically to the centers of the wheels, at the axles.

### 3.1.3 Loading

The loading on this model is defined from the profile of the track. The track deformations are defined based on motions of the transition spans at the ends of the floating section of the bridge. The maximum deflections are based on the following rotations of the transition spans:

Horizontal motion: expansion joint rotation of  $1.1^\circ$  about a vertical axis.

Vertical motion: expansion joint rotation of  $2.2^\circ$  about a transverse horizontal axis.

These deformations were developed using the track bridge model documented in [2]. The resulting track profiles were used as inputs to the vehicle dynamics model. Deformations of the track were applied to the axles as applied displacements in a dynamic model, which simulated the passage of the train over the expansion joint. A program was written to convert the rail profiles into deformation time histories at each of the wheels, based on the train speed.

Before the dynamic analysis can be run, the train must be preloaded with gravity. This was accomplished in the following manner:

1. A static analysis was performed using only a gravity load.
2. The displacements under gravity were extracted, and reformatted as initial nodal displacements
3. The initial displacements were read into a dynamic analysis, along with gravity defined as fully active at time  $t=0$ .
4. An initial velocity was defined, corresponding to the train velocity desired.

This allowed the train to have the proper initial velocity and gravity load without any oscillation or acceleration period in the analysis.

Analyses were run for the following load combinations:

1. 100% horizontal motion ( $1.1^\circ$  rotation about a vertical axis)
2. 50% horizontal motion
3. 100% vertical motion ( $2.2^\circ$  rotation about a horizontal axis)

<b>I-90 Homer Hadley Floating Bridge – LRT Impacts</b>		<b>SC Solutions</b>
<b>Subject/Description: Vehicle Dynamics Analysis</b>	Originator: T. E. Abrahamson	Date:
Disclaimer: The analysis in this technical document is preliminary and is strictly to be used as advice in determining the feasibility of placing the LRT on the Homer Hadley Floating Bridge and approach spans. It is not intended for any other purpose or as the basis for any final design or construction issue associated with this project.	Checked: A. Kozak	Date:
	Rev No.: 0	Sheet 13 of 25

4. 50% vertical motion
5. 100% horizontal + 100% vertical
6. 75% horizontal + 75% vertical
7. 50% horizontal + 50% vertical
8. 25% horizontal + 25% vertical

Each of the above 8 basic cases was performed for each of the 4 car configurations (AW0 to AW3), and at a variety of speeds. In each case, the track loads and train car accelerations were extracted.

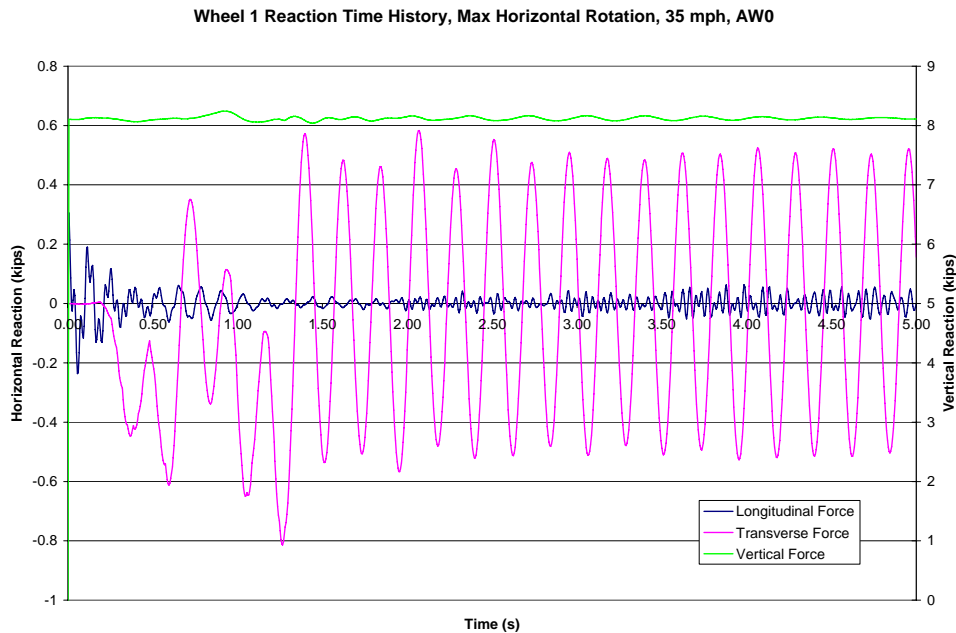
### **3.2 Analysis Results**

#### **3.2.1 Track Loads**

##### **3.2.1.1 Case 1: 100% Horizontal Rotation**

The reactions at wheel 1 for case 1 in condition AW0 at 35 mph are shown in Figure 3-7. Loads on other wheels were similar. This is the only set of wheel reactions that was used to determine if the rails were strongly affected by the train passage. The analysis documented in [2] demonstrated that the motion of the rails due to the wheel loads was negligible compared to the overall expansion joint deformations. Therefore a more detailed vehicle – rail structural interaction analysis has not been conducted. All vehicle dynamics analyses assumed that the rails were fixed in their expansion joint deformed condition. Wheel reactions for other cases are not presented here.

<b>I-90 Homer Hadley Floating Bridge – LRT Impacts</b>		<b>SC Solutions</b>
<b>Subject/Description: Vehicle Dynamics Analysis</b>	Originator: T. E. Abrahamson	Date:
Disclaimer: The analysis in this technical document is preliminary and is strictly to be used as advice in determining the feasibility of placing the LRT on the Homer Hadley Floating Bridge and approach spans. It is not intended for any other purpose or as the basis for any final design or construction issue associated with this project.	Checked: A. Kozak	Date:
	Rev No.: 0	Sheet 14 of 25



**Figure 3-7: Wheel 1 Reaction, Max Horizontal Rotation, 35 MPH, Condition AW0**

### 3.2.2 Train Accelerations

Train accelerations were measured at the mass point representing the train and passenger mass. The limits for the accelerations are defined as follows:

The rms acceleration values shall not exceed the 4-hour, reduced comfort level (vertical) and 2.5 hr, reduced comfort level (horizontal) boundaries derived from Figure 2a (vertical) and Figure 3a (horizontal) of ISO 2631 over the range of 1 Hz to 80 Hz, for all load conditions AW0 to AW3.

For vertical, the acceleration limit chart is reproduced in Figure 3-8. This shows the limits for fatigue decreased proficiency. The accompanying text indicates that for comfort level, the values should be divided by 3.15. The data was reformatted in g units instead of  $m/s^2$ , divided by 3.15 for comfort level, and replotted in Figure 3-9.

Subject/Description: **Vehicle Dynamics Analysis**

Originator: T. E. Abrahamson

Date:

Disclaimer: The analysis in this technical document is preliminary and is strictly to be used as advice in determining the feasibility of placing the LRT on the Homer Hadley Floating Bridge and approach spans. It is not intended for any other purpose or as the basis for any final design or construction issue associated with this project.

Checked: A. Kozak

Date:

Rev No.: 0

Sheet 15 of 25

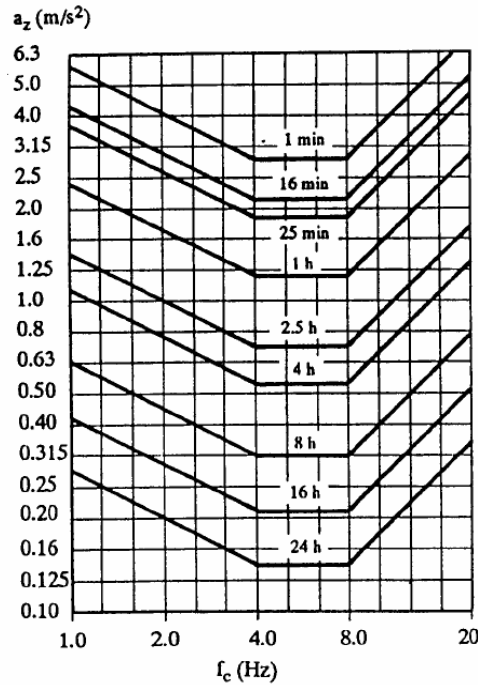


Figure 3-8: Vertical Acceleration Limits

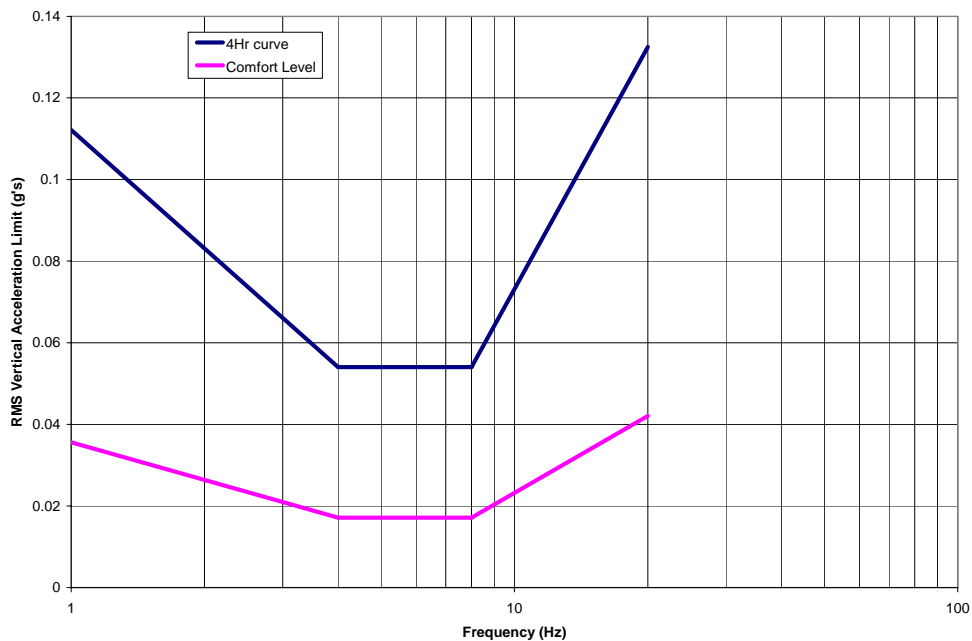
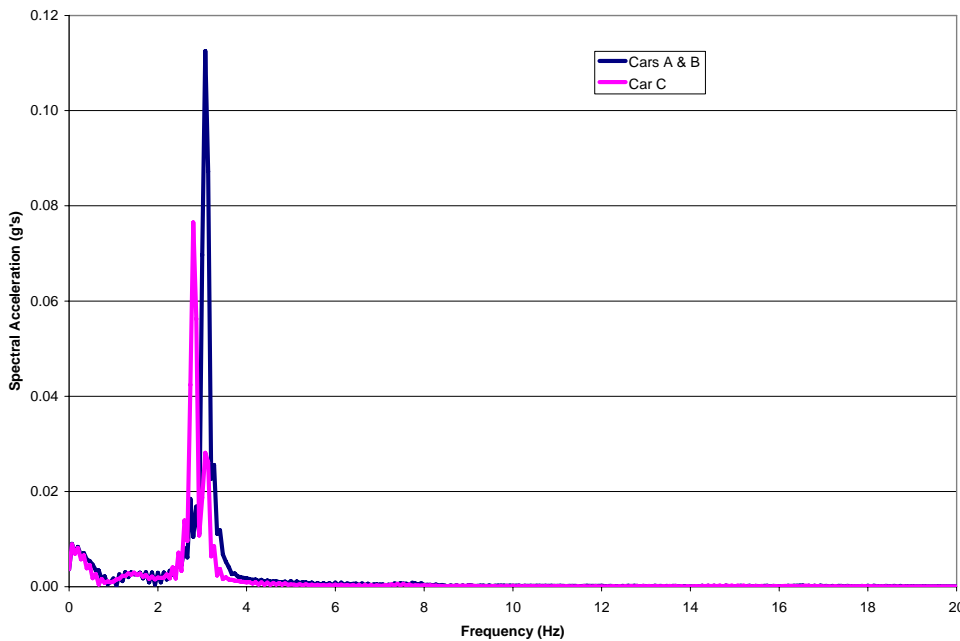


Figure 3-9: Reformatted Vertical Acceleration Limits

<b>I-90 Homer Hadley Floating Bridge – LRT Impacts</b>		<b>SC Solutions</b>
<b>Subject/Description: Vehicle Dynamics Analysis</b>	Originator: T. E. Abrahamson	Date:
Disclaimer: The analysis in this technical document is preliminary and is strictly to be used as advice in determining the feasibility of placing the LRT on the Homer Hadley Floating Bridge and approach spans. It is not intended for any other purpose or as the basis for any final design or construction issue associated with this project.	Checked: A. Kozak	Date:
	Rev No.: 0	Sheet 16 of 25

The vertical spectral acceleration is plotted in Figure 3-10 for the maximum vertical rotation ( $2.2^\circ$ ), 35 mph, and load condition AW0. The frequency response is a single sharp peak at about 3 Hz for each of the cars. For different load configurations, the frequency of the peak drops to about 2.5 Hz, but the sharp single peak characteristic remains. Therefore, the RMS can be computed for the entire spectrum. The limit for this RMS value is 0.021 g's.

In the horizontal direction, an alternate option is presented, based on a single amplitude acceleration, which corresponds to the peak acceleration. For comfort level acceleration, the limit is 0.07 g's.



**Figure 3-10: Vertical Spectral Acceleration, 35 mph, AW0**

### 3.2.2.1 Case 1: 100% Horizontal Rotation

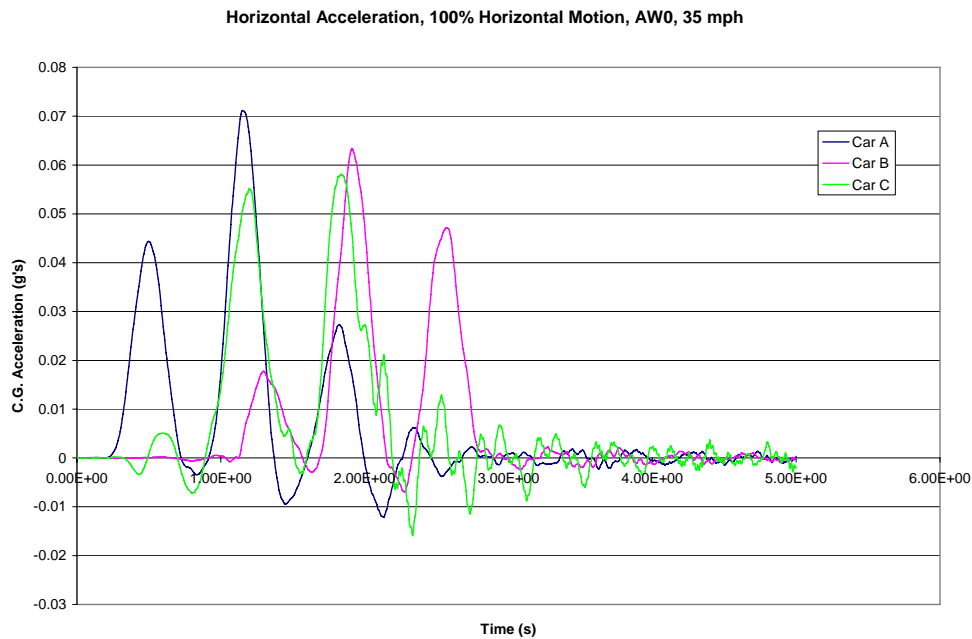
For horizontal track deformation at a  $1.1^\circ$  angle, the results are shown in Figure 3-11 and Figure 3-12. Figure 3-11 shows the time history of the c.g. accelerations in each of the 3 cars as the train passes the expansion joint for the case of configuration AW0 at 35 mph. Figure 3-12 shows the peak horizontal acceleration for all configurations (AW0 to AW3),

<b>I-90 Homer Hadley Floating Bridge – LRT Impacts</b>		<b>SC Solutions</b>
<b>Subject/Description: Vehicle Dynamics Analysis</b>	Originator: T. E. Abrahamson	Date:
Disclaimer: The analysis in this technical document is preliminary and is strictly to be used as advice in determining the feasibility of placing the LRT on the Homer Hadley Floating Bridge and approach spans. It is not intended for any other purpose or as the basis for any final design or construction issue associated with this project.	Checked: A. Kozak	Date:
	Rev No.: 0	Sheet 17 of 25

and speeds from 25 to 35 mph. The recommended limit on acceleration is 0.07g, which is also shown on Figure 3-12. For this case, the train must travel at no more than about 33 mph to limit the lateral accelerations to 0.07g.

### 3.2.2.2 Case 2: 50% Horizontal Rotation

For horizontal track deformation at a 0.55° angle, the results are shown in Figure 3-13. This shows the peak horizontal acceleration for all configurations (AW0 to AW3), and speeds from 35 to 45 mph. The recommended limit on acceleration is 0.07g, which is also shown on Figure 3-13. For this case, the train must travel at no more than about 41 mph to limit the lateral accelerations to 0.07g.



**Figure 3-11: Lateral acceleration with 1.1° horizontal rotation at joint**

Subject/Description: **Vehicle Dynamics Analysis**

Originator: T. E. Abrahamson

Date:

Disclaimer: The analysis in this technical document is preliminary and is strictly to be used as advice in determining the feasibility of placing the LRT on the Homer Hadley Floating Bridge and approach spans. It is not intended for any other purpose or as the basis for any final design or construction issue associated with this project.

Checked: A. Kozak

Date:

Rev No.: 0

Sheet 18 of 25

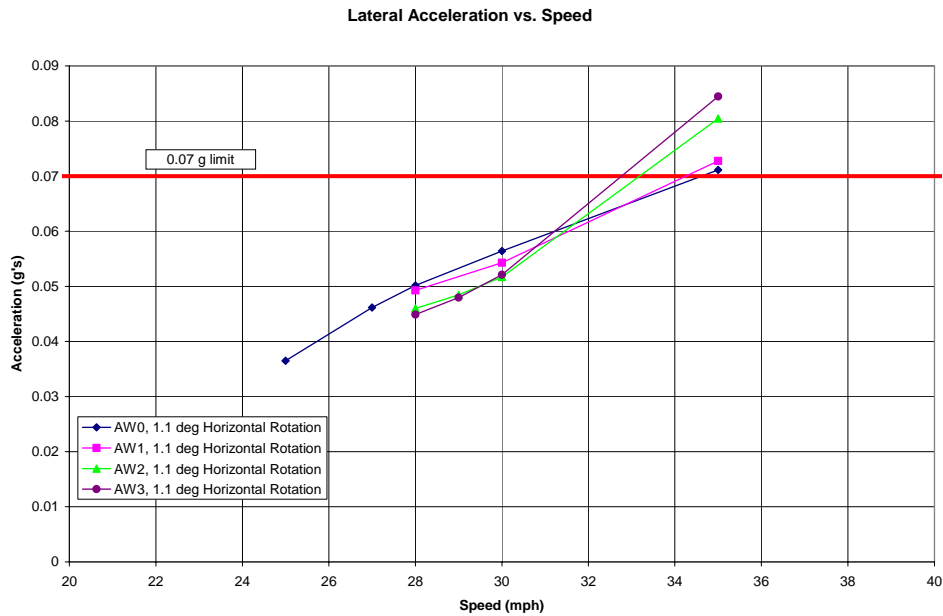


Figure 3-12: Peak Horizontal Acceleration vs. Speed, 100% Horizontal Rotation

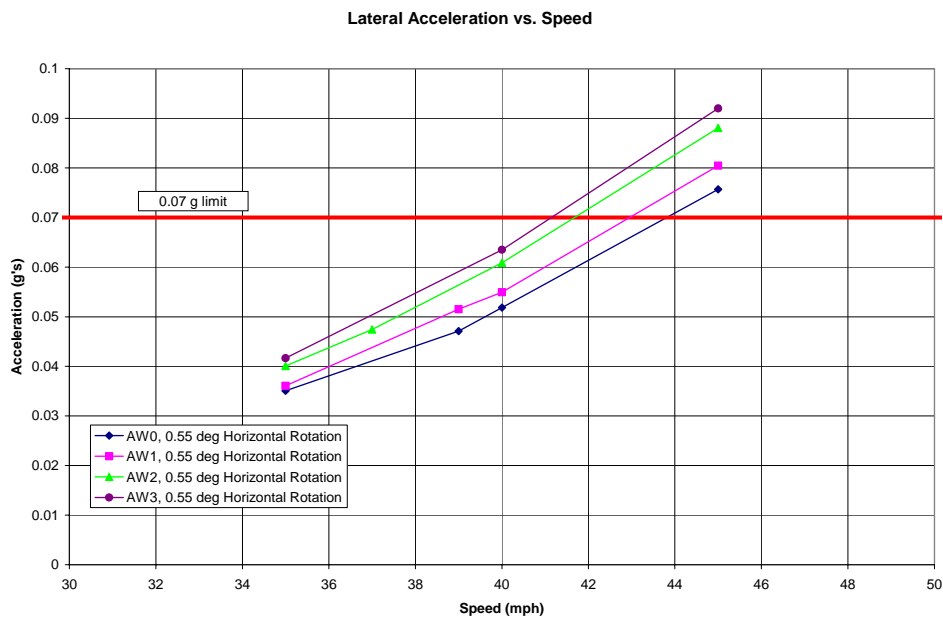


Figure 3-13: Peak Horizontal Acceleration vs. Speed, 50% Horizontal Rotation.



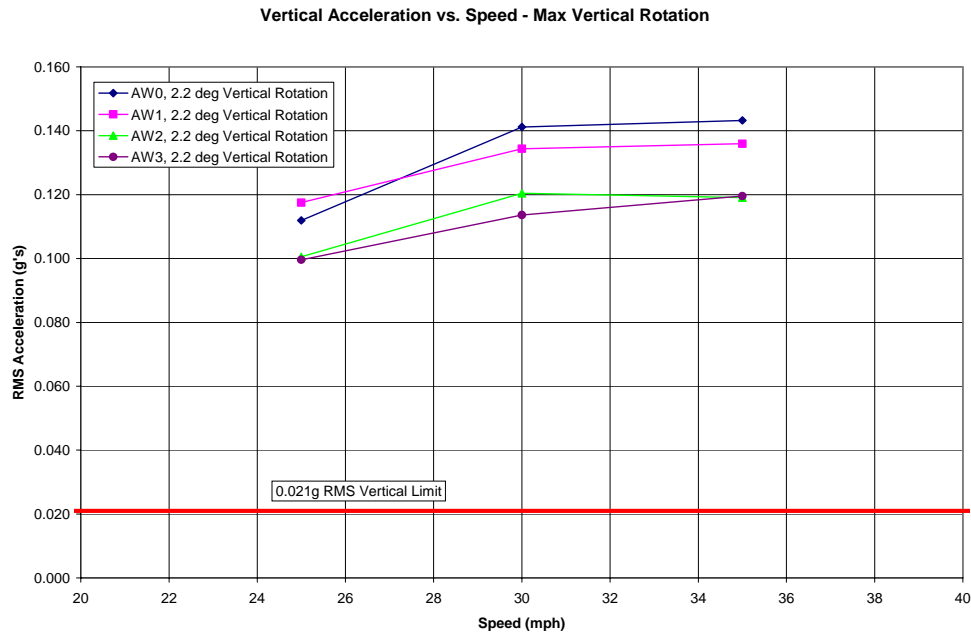
<b>I-90 Homer Hadley Floating Bridge – LRT Impacts</b>		<b>SC Solutions</b>
<b>Subject/Description: Vehicle Dynamics Analysis</b>	Originator: T. E. Abrahamson	Date:
Disclaimer: The analysis in this technical document is preliminary and is strictly to be used as advice in determining the feasibility of placing the LRT on the Homer Hadley Floating Bridge and approach spans. It is not intended for any other purpose or as the basis for any final design or construction issue associated with this project.	Checked: A. Kozak	Date:
	Rev No.: 0	Sheet 19 of 25

### 3.2.2.3 Case 3: 100% Vertical Rotation

For vertical track deformation at a 2.2° angle, the results are shown in Figure 3-14. The RMS accelerations were computed over the entire spectra, as the spectra exhibited sharp peaks at about 2.5 to 3 Hz for all cases. The RMS vertical accelerations are significantly higher than the allowable of 0.021 g limit for passenger comfort for all load conditions and speeds. The speed would have to be significantly less than 25 mph to reduce the acceleration below the allowable.

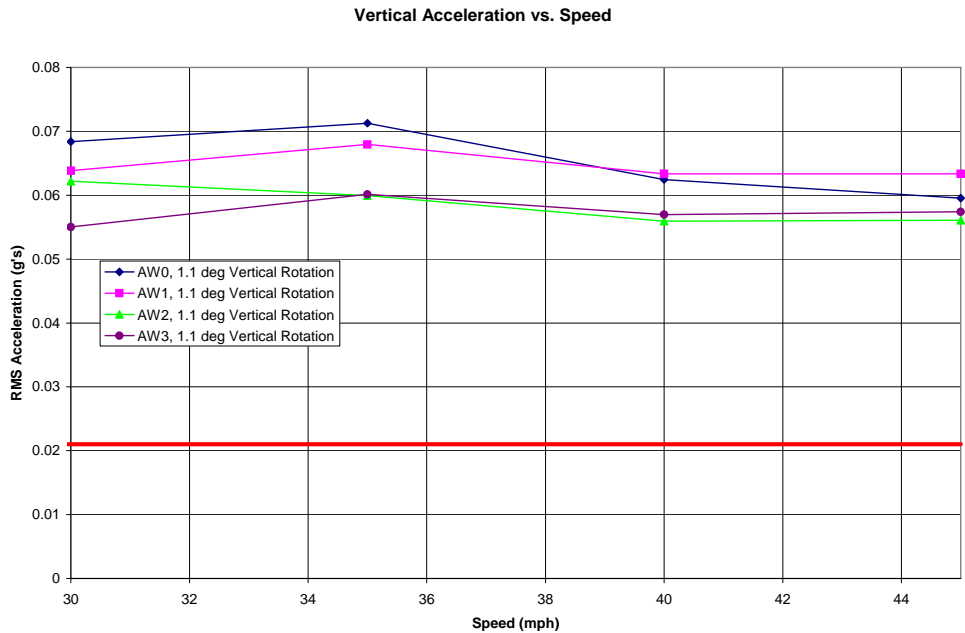
### 3.2.2.4 Case 4: 50% Vertical Rotation

For vertical track deformation at a 1.1° angle, the results are shown in Figure 3-15. The RMS accelerations were computed over the entire spectra, as the spectra exhibited sharp peaks at about 2.5 to 3 Hz for all cases. The RMS vertical accelerations are significantly higher than the allowable of 0.021 g limit for passenger comfort for all load conditions and speeds. The speed would have to be significantly less than 30 mph to reduce the acceleration below the allowable.



**Figure 3-14: RMS Vertical acceleration with 2.2° Vertical rotation at joint**

<b>I-90 Homer Hadley Floating Bridge – LRT Impacts</b>		<b>SC Solutions</b>
<b>Subject/Description: Vehicle Dynamics Analysis</b>	Originator: T. E. Abrahamson	Date:
Disclaimer: The analysis in this technical document is preliminary and is strictly to be used as advice in determining the feasibility of placing the LRT on the Homer Hadley Floating Bridge and approach spans. It is not intended for any other purpose or as the basis for any final design or construction issue associated with this project.	Checked: A. Kozak	Date:
	Rev No.: 0	Sheet 20 of 25



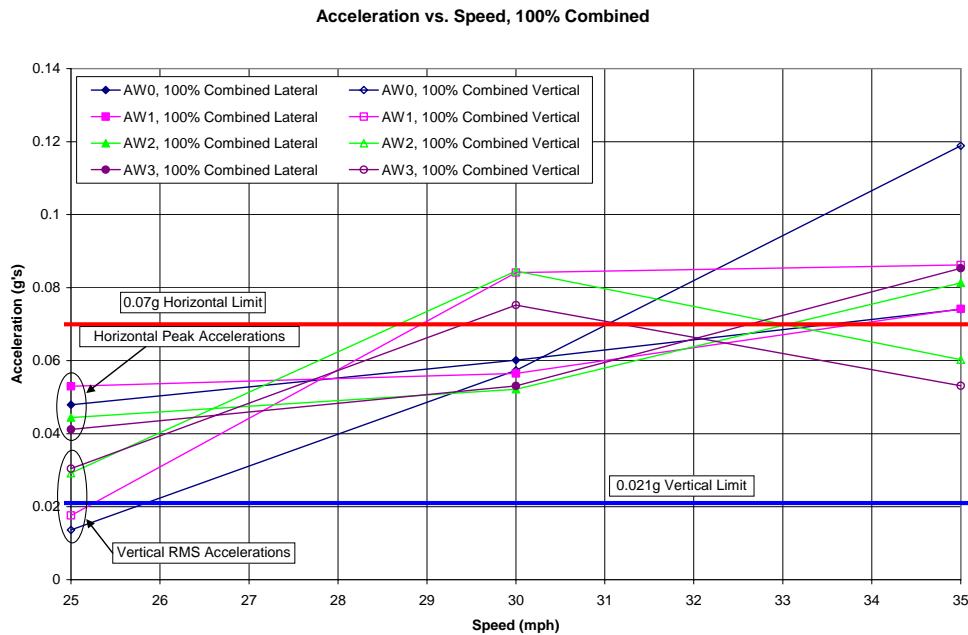
**Figure 3-15: RMS Vertical acceleration with 1.1° vertical rotation at joint.**

**3.2.2.5 Case 5: 100% Vertical Rotation + 100% Horizontal Rotation**

The horizontal and vertical rotation cases will occur in some combination. The most severe possible is the simultaneous occurrence of the maximum horizontal rotation and the maximum vertical rotation at the same time. This may be overly conservative, as these extreme cases are each not likely to occur.

For vertical rotation at a 2.2° angle, and a horizontal rotation of 1.1°, the results are shown in Figure 3-16. The RMS accelerations were computed over the entire spectra, as the spectra exhibited sharp peaks at about 2.5 to 3 Hz for all cases. The RMS vertical accelerations satisfy the 0.021g limit at 25 mph for AW0 and AW1, but not for any other load conditions or speeds. To satisfy the limit for all conditions, the speed would have to be reduced to about 23 mph. For horizontal accelerations, the peak is below the 0.07g limit for speeds of 32 mph or less.

<b>I-90 Homer Hadley Floating Bridge – LRT Impacts</b>		<b>SC Solutions</b>
<b>Subject/Description: Vehicle Dynamics Analysis</b>	Originator: T. E. Abrahamson	Date:
Disclaimer: The analysis in this technical document is preliminary and is strictly to be used as advice in determining the feasibility of placing the LRT on the Homer Hadley Floating Bridge and approach spans. It is not intended for any other purpose or as the basis for any final design or construction issue associated with this project.	Checked: A. Kozak	Date:
	Rev No.: 0	Sheet 21 of 25



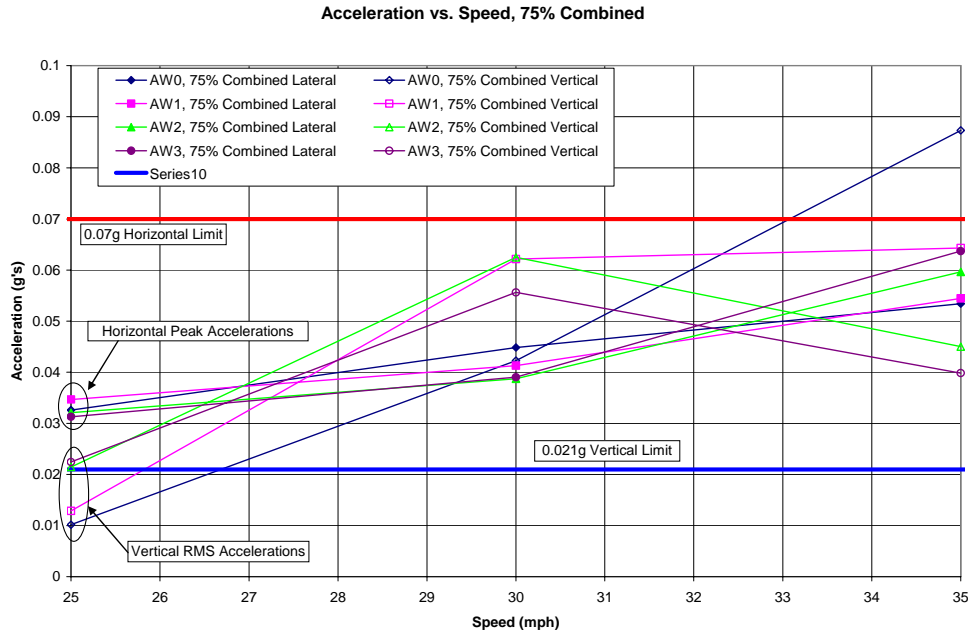
**Figure 3-16: RMS Vertical and Peak Horizontal Acceleration with 2.2° Vertical and 1.1° Horizontal Rotation at Joint.**

### 3.2.2.6 Case 6: 75% Vertical Rotation + 75% Horizontal Rotation

The combination of 75% horizontal and vertical rotations at the expansion joint has rotations of 1.65° vertical and 0.825° horizontal. This is still much more severe than the ultimate event in the vertical direction (1.25°), but is close to the ultimate horizontal event (1°). The annual event is defined as 0.4 vertical and 0.2 horizontal, so this case is much more severe than the annual event in both directions.

For vertical rotation at a 1.65° angle, and a horizontal rotation of 0.825°, the results are shown in Figure 3-17. The RMS accelerations were computed over the entire spectra, as the spectra exhibited sharp peaks at about 2.5 to 3 Hz for all cases. The RMS vertical accelerations satisfy the 0.021 g limit at 25 mph for all but the AW3 load condition. The AW3 condition is very close to the acceleration limit at 25 mph. At 24 mph, all load conditions satisfy the acceleration limit. At higher speeds, the limit is not satisfied for any load condition. For horizontal accelerations, the peak is below the 0.07g limit for all speeds, examined, up to 35 mph. The speed could be slightly higher than 35 mph and still satisfy the 0.07g guideline.

<b>I-90 Homer Hadley Floating Bridge – LRT Impacts</b>		<b>SC Solutions</b>
<b>Subject/Description: Vehicle Dynamics Analysis</b>	Originator: T. E. Abrahamson	Date:
Disclaimer: The analysis in this technical document is preliminary and is strictly to be used as advice in determining the feasibility of placing the LRT on the Homer Hadley Floating Bridge and approach spans. It is not intended for any other purpose or as the basis for any final design or construction issue associated with this project.	Checked: A. Kozak	Date:
	Rev No.: 0	Sheet 22 of 25



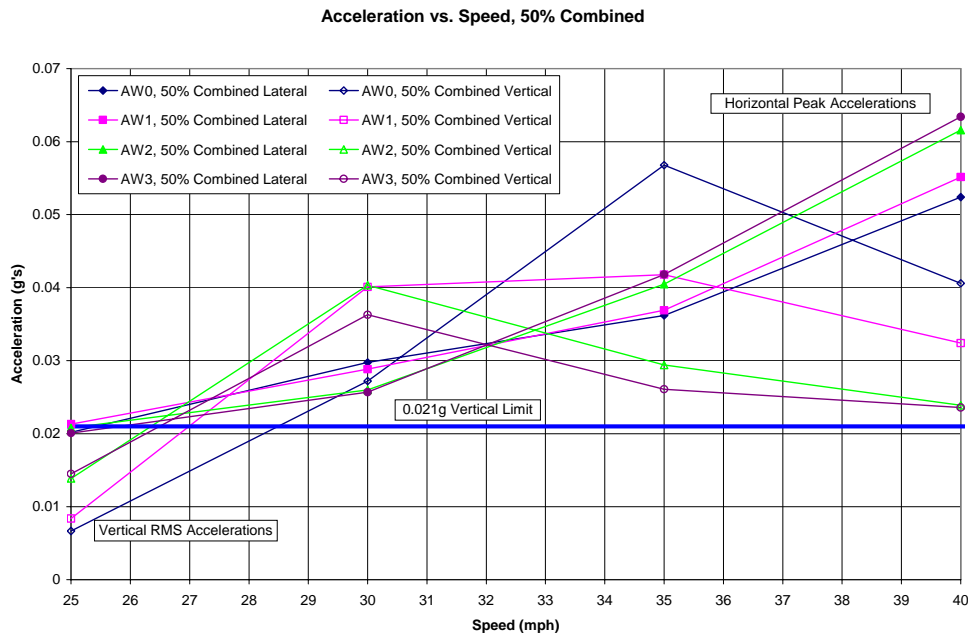
**Figure 3-17: RMS Vertical and Peak Horizontal Acceleration with 1.65° Vertical and 0.825° Horizontal Rotation at Joint.**

### 3.2.2.7 Case 7: 50% Vertical Rotation + 50% Horizontal Rotation

The combination of 50% horizontal and vertical rotations at the expansion joint has rotations of 1.1° vertical and 0.55° horizontal. This is about the same as the ultimate event in the vertical direction (1.25°), and is lower than the ultimate horizontal event (1°). The annual event is defined as 0.4 vertical and 0.2 horizontal, so this case is more severe than the annual event in both directions.

For vertical rotation at a 1.1° angle, and a horizontal rotation of 0.55°, the results are shown in Figure 3-18. The RMS accelerations were computed over the entire spectra, as the spectra exhibited sharp peaks at about 2.5 to 3 Hz for all cases. The RMS vertical accelerations satisfy the 0.021g limit for all load conditions at speeds up to 26 mph. At higher speeds, the accelerations exceed the limit. For horizontal accelerations, the peak is below the 0.07g limit for all speeds, examined, up to 40 mph. The speed could be slightly higher than 40 mph and still satisfy the 0.07g guideline.

<b>I-90 Homer Hadley Floating Bridge – LRT Impacts</b>		<b>SC Solutions</b>
<b>Subject/Description: Vehicle Dynamics Analysis</b>	Originator: T. E. Abrahamson	Date:
Disclaimer: The analysis in this technical document is preliminary and is strictly to be used as advice in determining the feasibility of placing the LRT on the Homer Hadley Floating Bridge and approach spans. It is not intended for any other purpose or as the basis for any final design or construction issue associated with this project.	Checked: A. Kozak	Date:
	Rev No.: 0	Sheet 23 of 25



**Figure 3-18: RMS Vertical and Peak Horizontal Acceleration with 1.1° Vertical and 0.55° Horizontal Rotation at Joint.**

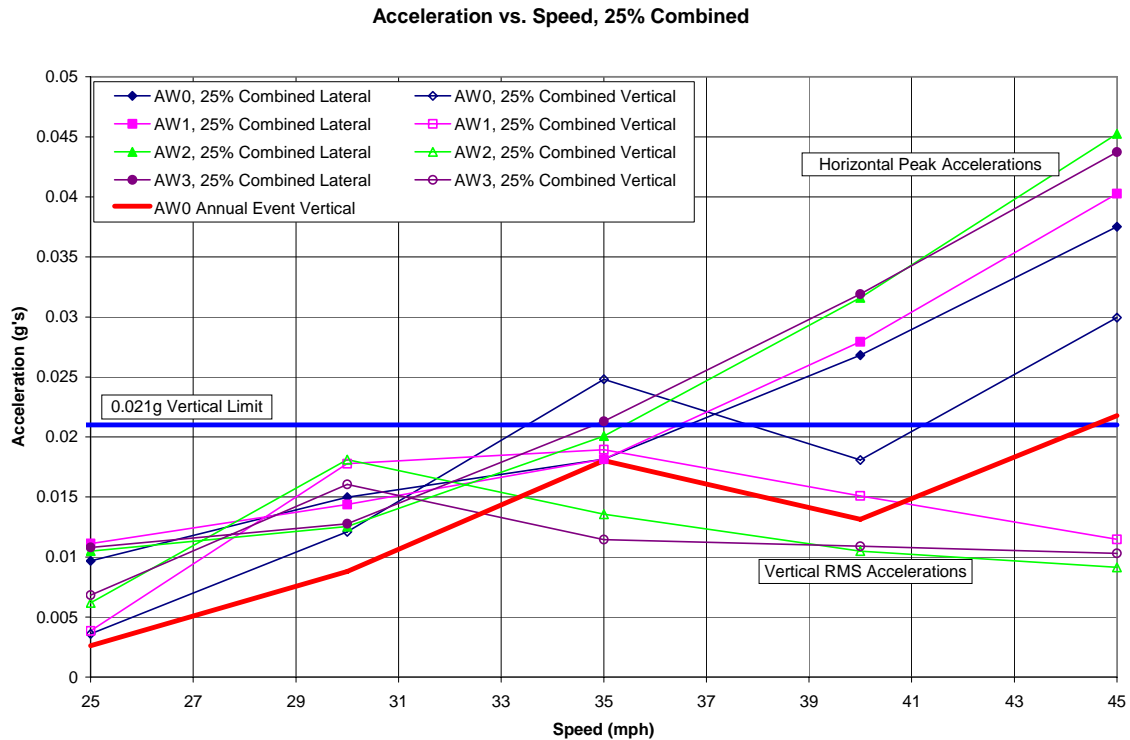
### 3.2.2.8 Case 8: 25% Vertical Rotation + 25% Horizontal Rotation

The combination of 25% horizontal and vertical rotations at the expansion joint has rotations of 0.55° vertical and 0.275° horizontal. This is slightly more severe than the annual event (0.4° vertical and 0.2° horizontal). This is approaching the only condition in which the train would actually be permitted to cross the bridge, as it will be closed during storm conditions.

For vertical rotation at a 0.55° angle, and a horizontal rotation of 0.275°, the results are shown in Figure 3-19. The RMS accelerations were computed over the entire spectra, as the spectra exhibited sharp peaks at about 2.5 to 3 Hz for all cases. The RMS vertical accelerations satisfies the 0.021 g limit for passenger comfort for all but the AW0 at 35 and 45 mph, at which speeds resonances occur that causes the acceleration to reach 0.025g and 0.03g. For horizontal accelerations, the peak is below the 0.07g limit for all speeds, examined, up to 45 mph. The speed could be higher than 45 mph and still satisfy the 0.07g guideline.

<b>I-90 Homer Hadley Floating Bridge – LRT Impacts</b>		<b>SC Solutions</b>
<b>Subject/Description: Vehicle Dynamics Analysis</b>	Originator: T. E. Abrahamson	Date:
Disclaimer: The analysis in this technical document is preliminary and is strictly to be used as advice in determining the feasibility of placing the LRT on the Homer Hadley Floating Bridge and approach spans. It is not intended for any other purpose or as the basis for any final design or construction issue associated with this project.	Checked: A. Kozak	Date:
	Rev No.: 0	Sheet 24 of 25

Reducing the load slightly to match the annual event conditions satisfies all acceleration requirements, for all speeds up to about 45 mph (red line in Figure 3-19)



**Figure 3-19: RMS Vertical and Peak Horizontal Acceleration with 0.55° Vertical and 0.275° Horizontal Rotation at Joint.**

#### 4. Conclusions

The train passing over the deformed expansion can experience large accelerations in the highly deformed conditions. However, the only condition in which the train would actually pass over the bridge would be the “annual event” condition. Case 8 was the only analytical case which was similar to that condition, and it included slightly larger expansion joint deformations than the annual even condition. In case 8, the horizontal acceleration limits were satisfied for all load conditions and all speeds up to 45 mph. The vertical acceleration limit was exceeded for load condition AW0 for speeds above about 33 mph. As the deformations were in excess of the actual annual event conditions. The accelerations would be lower for the annual event. It is likely that the speeds could be

<b>I-90 Homer Hadley Floating Bridge – LRT Impacts</b>		<b>SC Solutions</b>
<b>Subject/Description: Vehicle Dynamics Analysis</b>	Originator: T. E. Abrahamson	Date:
Disclaimer: The analysis in this technical document is preliminary and is strictly to be used as advice in determining the feasibility of placing the LRT on the Homer Hadley Floating Bridge and approach spans. It is not intended for any other purpose or as the basis for any final design or construction issue associated with this project.	Checked: A. Kozak	Date:
	Rev No.: <b>0</b>	Sheet 25 of 25

increased to 45 mph and still satisfy both horizontal and vertical acceleration limits, but the additional analysis has not been conducted.

**I-90 Homer Hadley Floating Bridge – LRT Impacts  
Technical Memorandum Cover Sheet**

**Technical Memorandum TM-05  
Seismic Vulnerability Assessment of the West Approach and  
Transition Spans**

**Prepared by: SC Solutions**  
**Date: August 6, 2008**

**Disclaimer:**

The analysis in this technical document is preliminary and is strictly to be used as advice in determining the feasibility of placing the LRT on the Homer Hadley Floating Bridge and approach spans. It is not intended for any other purpose or as the basis for any final design or construction issue associated with this project.



<b>I-90 Homer Hadley Floating Bridge – LRT Impacts</b>		<b>SC Solutions</b>
<b>Subject/Description: Seismic Vulnerability Assessment of the West Approach and Transition Spans</b>	Originator: Joyce Kin-Yan Lee	Date: 8/6/2008
	Checked: Hassan Sedarat	Date: 8/6/2008
Disclaimer: The analysis in this technical document is preliminary and is strictly to be used as advice in determining the feasibility of placing the LRT on the Homer Hadley Floating Bridge and approach spans. It is not intended for any other purpose or as the basis for any final design or construction issue associated with this project	Calculation No.:TM-05	
	Rev No.: 0	Sheet 2 of 62

### Table of Contents

<b>1. Introduction .....</b>	<b>3</b>
<b>2. Basis for Analysis.....</b>	<b>3</b>
2.1 Calculation Scope .....	4
2.2 Criteria, Codes and Standards.....	4
<b>3. Discussion.....</b>	<b>4</b>
3.1 Model Development.....	4
3.2 Geometry.....	4
3.3 Connectivity - Element Groups .....	6
3.4 Boundary Conditions .....	10
3.5 Soil-Structure Interaction.....	10
3.6 Material – Elastic Elements .....	11
3.7 Moment-Curvature Relations – Nonlinear Plastic Elements .....	12
3.7.1 General.....	12
3.8 Elastic Section Properties .....	28
3.9 Superstructure Section Properties, and Masses of Superstructure.....	30
3.10 Transverse Beam Section at Pier 2 .....	32
3.11 Mode Shapes and Frequencies.....	33
3.12 Input Spectrum.....	39
3.13 Response Spectrum Analysis.....	39
3.14 Pushover Analysis.....	39
3.14.1 Target Displacements at Piers, Abutment and Pontoon.....	40
3.15 Summary of the Results – Pushover Analysis .....	41
3.15.1 Distribution of Plastic Curvature .....	41
3.15.2 Column Drift.....	48
3.15.3 Column Strains.....	49
3.15.4 Force-Displacement Relationship.....	53
<b>4. Conclusions/Recommendations.....</b>	<b>61</b>
<b>5. References .....</b>	<b>61</b>

<b>I-90 Homer Hadley Floating Bridge – LRT Impacts</b>		<b>SC Solutions</b>
<b>Subject/Description: Seismic Vulnerability Assessment of the West Approach and Transition Spans</b>	Originator: Joyce Kin-Yan Lee	Date: 8/6/2008
	Checked: Hassan Sedarat	Date: 8/6/2008
Disclaimer: The analysis in this technical document is preliminary and is strictly to be used as advice in determining the feasibility of placing the LRT on the Homer Hadley Floating Bridge and approach spans. It is not intended for any other purpose or as the basis for any final design or construction issue associated with this project	Calculation No.:TM-05	
	Rev No.: 0	Sheet 3 of 62

## 1. Introduction

The Homer Hadley Floating Bridge was designed in the early 1980s. This technical memorandum presents the preliminary findings of a seismic vulnerability assessment of the west approach and the transition span of the bridge performed by SC Solutions. A seismic evaluation of the approach of the Line M was performed by INCA in the past [1]. Since seismic vulnerability of Line L might affect that of Line M, SC Solutions analyzed both Lines L and M.

## 2. Basis for Analysis

There-dimensional model of the Lines L and M including the curved layout of the Line M is developed using the existing drawings [4]. The general purpose finite element program ADINA [2] is used throughout this study. In lieu of a more accurate nonlinear dynamic time-history analysis, a pushover analysis is used in this preliminary study. In order to perform nonlinear dynamic time-history analysis, it is necessary to have ground displacements time-histories at each pier, and proper articulation of the soil structure interaction. The latter is usually done using PY soil springs along the height of piles and the ground motions are applied to the ground nodes of the soil springs. Generating the ground displacement time-histories and PY curves were beyond the scope of this study. It is strongly recommended that a nonlinear time-history analysis be used for the next phase of the analysis. What presented in this tech memo is a preliminary analysis.

All piers are modeled with nonlinear concrete material, while superstructure and piles are assumed to remain linear elastic. It appears that piles are concrete with steel pipe. Based on the connection of the pile to the pile cap detail [4], it appears that the steel pipe provide confinement and not strength and/or stiffness. Therefore, the piles are modeled with concrete sectional properties without steel pipe. In this study the piles are modeled to the point of fixity. The elevation of point of fixity was approximated. A more detailed study is required by a geotechnical engineer to provide a better estimate of the depth of the point of fixity. The response spectrum analysis is performed to obtain mode shapes, frequencies and target displacements. A 1000-year design spectrum for site class D is used [5]The pushover analysis is conducted to the target displacement and about 30% more. At the target displacement, column drift and strains in the piers are summarized as well as distribution of the plastic curvature. These demands are compared with the associated capacities as potential damage indices.

<b>I-90 Homer Hadley Floating Bridge – LRT Impacts</b>		<b>SC Solutions</b>
<b>Subject/Description: Seismic Vulnerability Assessment of the West Approach and Transition Spans</b>	Originator: Joyce Kin-Yan Lee	Date: 8/6/2008
	Checked: Hassan Sedarat	Date: 8/6/2008
Disclaimer: The analysis in this technical document is preliminary and is strictly to be used as advice in determining the feasibility of placing the LRT on the Homer Hadley Floating Bridge and approach spans. It is not intended for any other purpose or as the basis for any final design or construction issue associated with this project	Calculation No.:TM-05	
	Rev No.: 0	Sheet 4 of 62

## 2.1 Calculation Scope

1. Develop three-dimensional nonlinear global model of the west approach structures. This Model includes both Lines L and M.
2. Compute the target displacement using a response spectrum analysis.
3. Perform pushover analysis.
4. Evaluate the demand at the target displacement and assess the vulnerabilities.

## 2.2 Criteria, Codes and Standards

1. North Light Rail, North Link and Airport Link Design Criteria Manual, November 2005
2. As-built drawings – SR 90 3rd Lake Washington Floating Bridge, Approaches and Transition Spans
3. FEMA 356 and FEMA 302
4. ADINA Version 8.3
5. SPEMC

## 3. Discussion

### 3.1 Model Development

The approach structure starts from abutment 1 to Pier 7. The transition structure starts from Pier 7 to Pontoon A-1. The approach's superstructure is a concrete segmental bridge, while the transition is a steel box girder. The approach's superstructure is fully connected to the piers, while the transition's superstructure is sitting on Pier 7 with bearings with pin connection.

### 3.2 Geometry

The elevation and plan view of the west approach for both lines L and M are shown in Figure 3-1. The three-dimensional model of the approach and transition structures were developed using the general purpose finite element program ADINA (see Figure 3-2). The plan view of the global model is shown in Figure 3-3. It is important to note that at pier 2 the two Lines L and M have a common framing/foundation system. Piers 2 and 3 are on spread footing, while the rest of the piers are supported by piles. The approach's superstructure at the pier 2 is supported by bearings, while it is integrally connected to the piers elsewhere. The transition span has a pin connection to pier 7. The superstructure, piers, piles bearings and all other structural components were explicitly modeled. All dimensions and sizes were obtained from drawings [4]

Subject/Description: **Seismic Vulnerability Assessment of the West Approach and Transition Spans**

Originator: Joyce Kin-Yan Lee  
 Checked: Hassan Sedarat

Date: 8/6/2008  
 Date: 8/6/2008

Disclaimer: The analysis in this technical document is preliminary and is strictly to be used as advice in determining the feasibility of placing the LRT on the Homer Hadley Floating Bridge and approach spans. It is not intended for any other purpose or as the basis for any final design or construction issue associated with this project

Calculation No.: TM-05

Rev No.: 0

Sheet 5 of 62

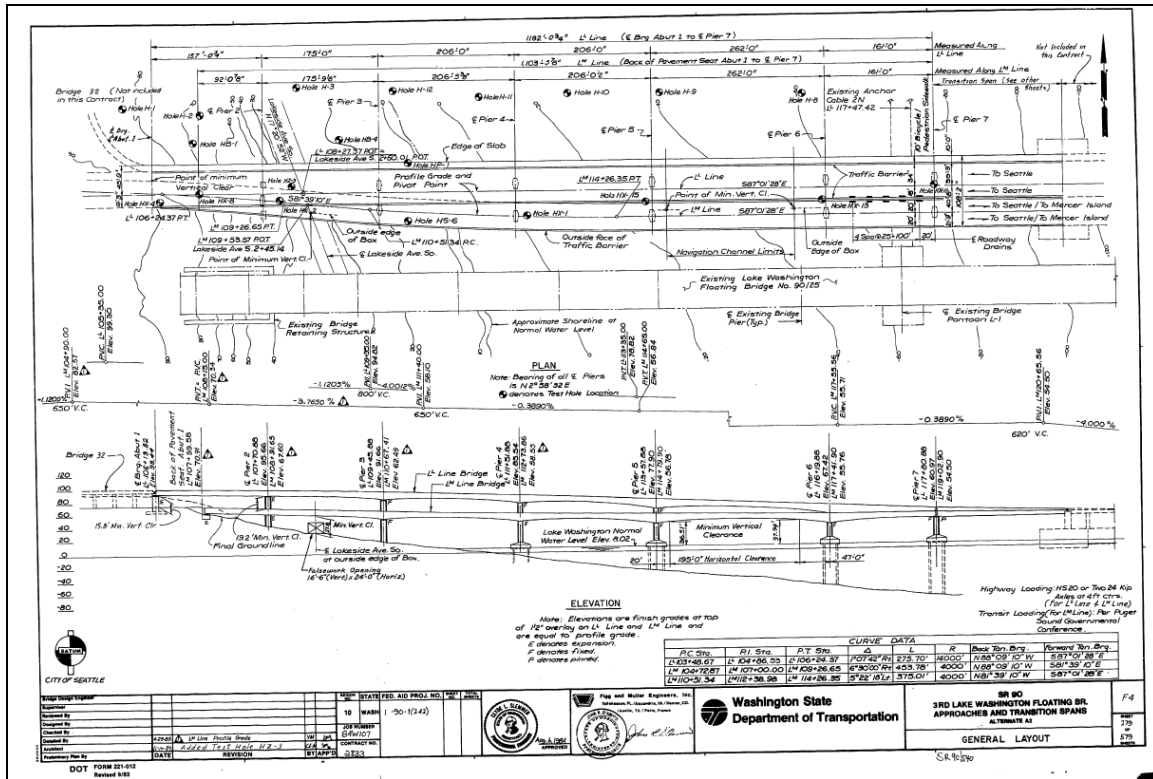
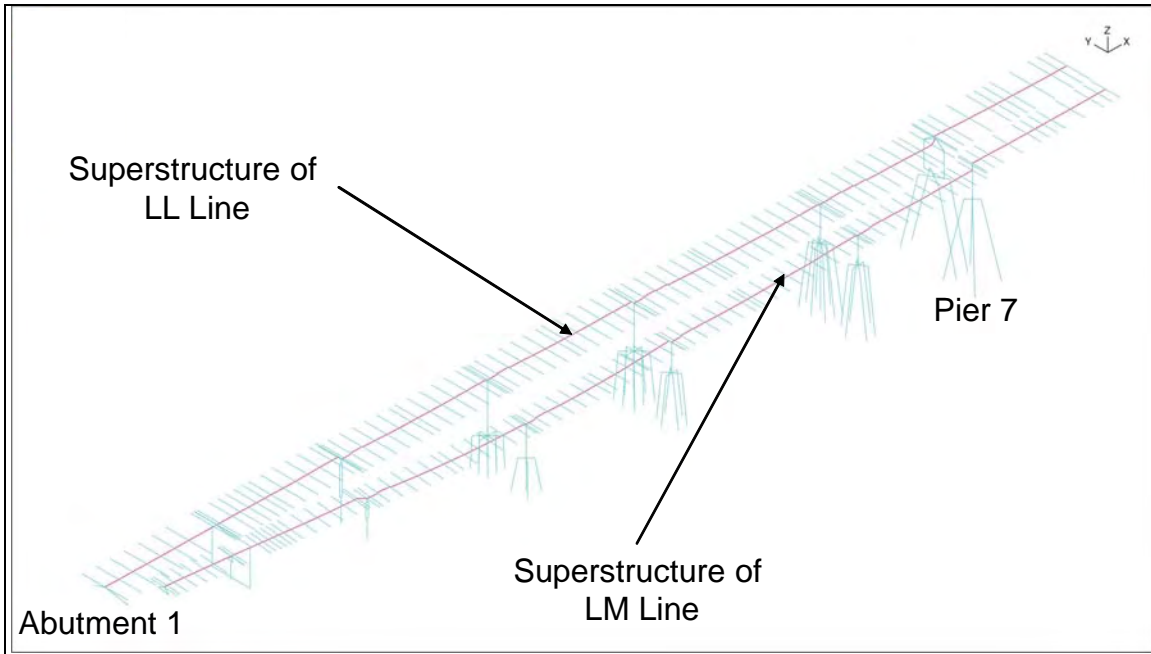
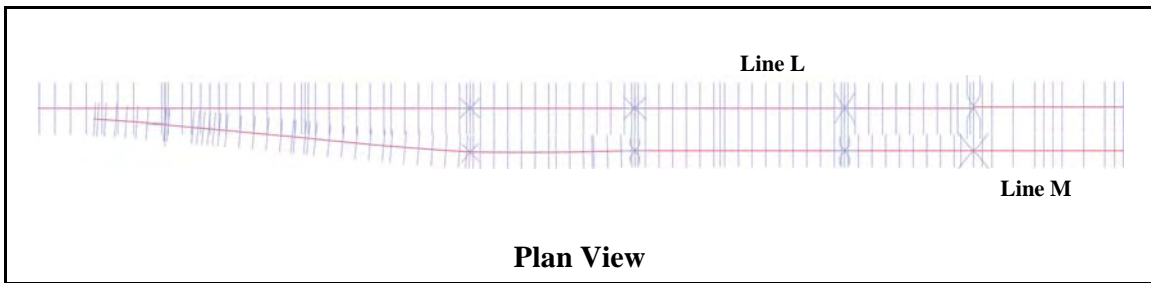


Figure 3-1: Approaches and Transition Spans

<b>I-90 Homer Hadley Floating Bridge – LRT Impacts</b>		<b>SC Solutions</b>
<b>Subject/Description: Seismic Vulnerability Assessment of the West Approach and Transition Spans</b>	Originator: Joyce Kin-Yan Lee	Date: 8/6/2008
	Checked: Hassan Sedarat	Date: 8/6/2008
Disclaimer: The analysis in this technical document is preliminary and is strictly to be used as advice in determining the feasibility of placing the LRT on the Homer Hadley Floating Bridge and approach spans. It is not intended for any other purpose or as the basis for any final design or construction issue associated with this project	Calculation No.:TM-05	
	Rev No.: 0	Sheet 6 of 62



**Figure 3-2: Global Model of the Approach and Transition Structure**



**Figure 3-3: Plan View of the Global Model**

### 3.3 Connectivity - Element Groups

All element groups and node numbering system are summarized in Table 3-1 and Table 3-2, respectively. Superstructures of both lines L and M were modeled using linear elastic beam elements. The outrigger elements were added to properly model the torsional mass inertia as shown in Figure 3-4. Outriggers were modeled using linear elastic rigid elements.

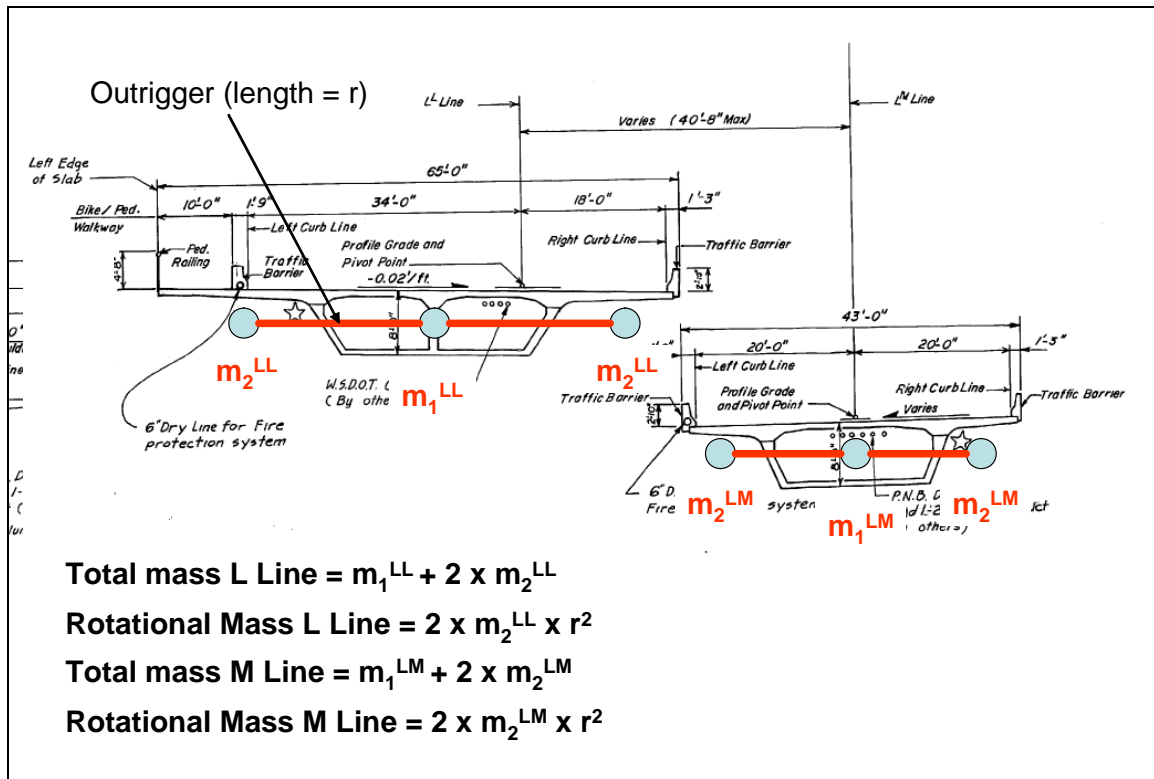
All Piers were modeled with nonlinear plastic material using ADINA [2] moment curvature elements. The program SPEMC [6] was used to compute the moment

<b>I-90 Homer Hadley Floating Bridge – LRT Impacts</b>		<b>SC Solutions</b>
<b>Subject/Description: Seismic Vulnerability Assessment of the West Approach and Transition Spans</b>	Originator: Joyce Kin-Yan Lee	Date: 8/6/2008
	Checked: Hassan Sedarat	Date: 8/6/2008
Disclaimer: The analysis in this technical document is preliminary and is strictly to be used as advice in determining the feasibility of placing the LRT on the Homer Hadley Floating Bridge and approach spans. It is not intended for any other purpose or as the basis for any final design or construction issue associated with this project	Calculation No.:TM-05	
	Rev No.: 0	Sheet 7 of 62

curvature relations. The material properties used for calculating moment curvature relations will be presented in the following sections.

Bearings are modeled with compression-only springs. Large displacements were used to include the effect of geometric nonlinearities.

Pier foundation for Piers 2 and 3 on both lines are fixed at the base of the spread footings. Other piers have pile foundation. All piles were explicitly modeled using linear elastic beam elements.



**Figure 3-4: Modeling of the Superstructures of Lines L and M**

**Table 3-1: Element Groups**

Element Group	Type	Description
1	Beam	Superstructure elements on line L.
2	Beam	Superstructure elements on line M.
3	Beam	Rigid “step” elements for connecting superstructure elements on

<b>I-90 Homer Hadley Floating Bridge – LRT Impacts</b>		<b>SC Solutions</b>
<b>Subject/Description: Seismic Vulnerability Assessment of the West Approach and Transition Spans</b>	Originator: Joyce Kin-Yan Lee	Date: 8/6/2008
	Checked: Hassan Sedarat	Date: 8/6/2008
Disclaimer: The analysis in this technical document is preliminary and is strictly to be used as advice in determining the feasibility of placing the LRT on the Homer Hadley Floating Bridge and approach spans. It is not intended for any other purpose or as the basis for any final design or construction issue associated with this project	Calculation No.:TM-05	
	Rev No.: 0	Sheet 8 of 62

		line L due to difference in centroid locations.
4	Beam	Rigid “step” elements for connecting superstructure elements on line M due to difference in centroid locations.
11	Beam	Rigid outrigger elements south (-ve y) of line L.
12	Beam	Rigid outrigger elements north (+ve y) of line L.
13	Beam	Rigid outrigger elements south (-ve y) of line M.
14	Beam	Rigid outrigger elements north (+ve y) of line M.
107	Beam	Rigid end element of abutment on superstructure level on line L.
108	Beam	Rigid beam elements connecting pier to superstructure at abutment 1 on line L.
109	Spring	Bearing elements at abutment 1 on line L.
201-204	Beam	Moment curvature elements of column at Pier 2 on line L.
205	Beam	Transverse beam elements connecting line L to line M at Pier 2.
206	Beam	Beam element to connect transverse beam to bearing at Pier 2 on line L.
208	Beam	Rigid elements at bearing at Pier 2 on line L.
209	Beam	Rigid beam elements connecting pier to superstructure on line L at Pier 2.
210	Spring	Bearing elements at Pier 2 on line L.
211	Beam	Rigid footing elements at Pier 2 on line L.
301-305	Beam	Moment curvature elements of column at Pier 3 on line L.
310	Beam	Rigid beam elements connecting pier to superstructure on line L at Pier 3.
312	Beam	Rigid footing elements at Pier 3 on line L.
*01-*05	Beam	Moment curvature elements of column at Pier on line L. (* refers to Pier 4 through 6)
*10	Beam	Rigid beam elements connecting pier to superstructure on line L at Pier. (* refers to Pier 4 through 6)
*12	Beam	Rigid footing elements at Pier on line L. (* refers to Pier 4 through 6)
*14	Beam	Foundation pile elements above ground level at Pier on line L. (* refers to Pier 4 through 6)
*15	Beam	Foundation pile elements below ground level at Pier on line L. (* refers to Pier 4 through 6)
*16	Beam	Rigid elements connecting footing to pile group at Pier on line L. (* refers to Pier 4 through 6)
701-704	Beam	Moment curvature elements of column at Pier 7 on line L.
709	Beam	Rigid beam elements connecting pier to superstructure on line L at Pier 7.
711	Beam	Rigid footing elements at Pier 7 on line L.
713	Beam	Foundation pile elements above ground level at Pier 7 on line L.
714	Beam	Foundation pile elements below ground level at Pier 7 on line L.

<b>I-90 Homer Hadley Floating Bridge – LRT Impacts</b>		<b>SC Solutions</b>
<b>Subject/Description: Seismic Vulnerability Assessment of the West Approach and Transition Spans</b>	Originator: Joyce Kin-Yan Lee	Date: 8/6/2008
	Checked: Hassan Sedarat	Date: 8/6/2008
Disclaimer: The analysis in this technical document is preliminary and is strictly to be used as advice in determining the feasibility of placing the LRT on the Homer Hadley Floating Bridge and approach spans. It is not intended for any other purpose or as the basis for any final design or construction issue associated with this project	Calculation No.:TM-05	
	Rev No.: 0	Sheet 9 of 62

715	Beam	Rigid elements connecting footing to pile group at Pier 7 on line L.
808	Beam	Rigid elements at bearing at Pontoon A on line L.
810	Spring	Bearing elements at Pontoon A on line L.
157	Beam	Rigid end element of abutment on superstructure level on line M.
158	Beam	Rigid elements at bearing on line M at abutment 1..
159	Beam	Rigid beam elements connecting pier to superstructure on line M at abutment 1.
160	Spring	Bearing elements at abutment 1 on line M.
251-254	Beam	Moment curvature elements of column at Pier 2 on line M.
258	Beam	Rigid elements at bearing at Pier 2 on line M.
259	Beam	Rigid beam elements connecting pier to superstructure on line M at Pier 2.
260	Spring	Bearing elements at Pier 2 on line M.
261	Beam	Rigid footing elements at Pier 2 on line M.
*51-*54	Beam	Moment curvature elements of column at Pier on line M. (* refers to Pier 3 through 7)
*59	Beam	Rigid beam elements connecting pier to superstructure on line M at Pier. (* refers to Pier 3 through 7)
*61	Beam	Rigid footing elements at Pier on line M. (* refers to Pier 3 through 7)
*63	Beam	Foundation pile elements above ground level at Pier on line M. (* refers to Pier 3 through 7)
*64	Beam	Foundation pile elements below ground level at Pier on line M. (* refers to Pier 3 through 7)
*65	Beam	Rigid elements connecting footing to pile group at Pier on line M. (* refers to Pier 3 through 7)
858	Beam	Rigid elements at bearing at Pontoon A on line M.
860	Spring	Bearing elements at Pontoon A on line M.

**Table 3-2: Node Numbering System**

<b>Node Number</b>	<b>Line</b>	<b>Description</b>
1??001 and 2??001 series	L	Superstructure nodes where ?? refers to pier number.
3??001 series	L	Auxiliary nodes for superstructure where ?? refers to pier number.
?001 series	L	Nodes at pier where ? represents pier number.
1??002 and 2??002 series	M	Superstructure nodes where ?? refers to pier number.
3??002 series	M	Auxiliary nodes for superstructure where ?? refers to pier number.
?002 series	M	Nodes at pier where ? represents pier number.



<b>I-90 Homer Hadley Floating Bridge – LRT Impacts</b>		<b>SC Solutions</b>
<b>Subject/Description: Seismic Vulnerability Assessment of the West Approach and Transition Spans</b>	Originator: Joyce Kin-Yan Lee	Date: 8/6/2008
	Checked: Hassan Sedarat	Date: 8/6/2008
Disclaimer: The analysis in this technical document is preliminary and is strictly to be used as advice in determining the feasibility of placing the LRT on the Homer Hadley Floating Bridge and approach spans. It is not intended for any other purpose or as the basis for any final design or construction issue associated with this project	Calculation No.:TM-05	
	Rev No.: 0	Sheet 10 of 62

### 3.4 Boundary Conditions

All piers have integral connection with the superstructures. Pier 7 to the transition span is pin connected. At abutments and at Pontoon, the longitudinal direction is free, while transverse is fixed. The vertical movement is controlled by compression-only springs. It is suggested that additional mass and possibly stiffness of the adjacent structure at Pontoon pier be added.

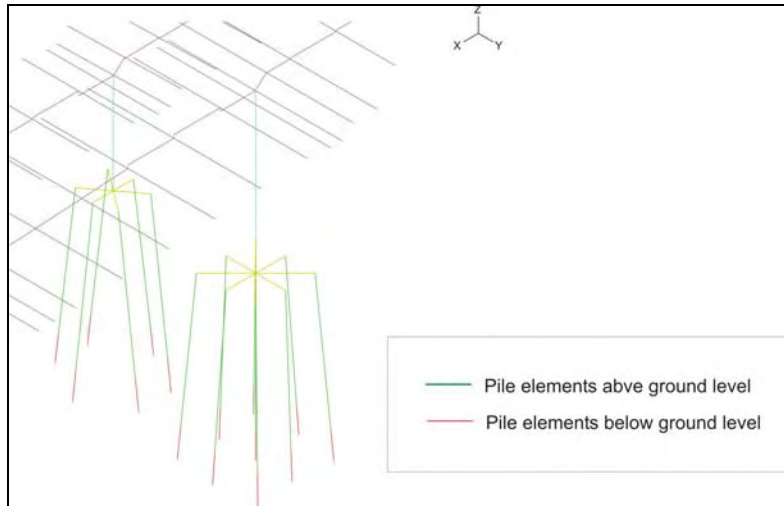
### 3.5 Soil-Structure Interaction

At the spread footing the piers are modeled with fixed base. It is suggested that soil impedance be used at the spread footings. Piles are explicitly modeled using linear elastic beam elements. Many of the piles are partially in the water and above the ground. Therefore, impedance for foundation system cannot be used. An approximate location of the point of fixity is specified for piles (Table 3-3 and Figure 3-5). In this way PY springs do not need to be specified and ground motions are applied only at the point of fixity. The ground surface elevations at each pier location were approximated from drawings (see Figure 3-1). The point of fixity is assumed to be about 2.5 times the diameter of the pile below the ground surface. A more detailed study by a geotechnical engineer is required to establish a better estimate of the depth of the point of fixity.

**Table 3-3: Pile Tip Elevation to the Point of Fixity**

	<b>Pile Tip Elevations (ft)</b>
at pier 4	-30
at pier 5	-50
at pier 6	-71.25
at pier 7	-91.25

<b>I-90 Homer Hadley Floating Bridge – LRT Impacts</b>		<b>SC Solutions</b>
<b>Subject/Description: Seismic Vulnerability Assessment of the West Approach and Transition Spans</b>	Originator: Joyce Kin-Yan Lee	Date: 8/6/2008
	Checked: Hassan Sedarat	Date: 8/6/2008
Disclaimer: The analysis in this technical document is preliminary and is strictly to be used as advice in determining the feasibility of placing the LRT on the Homer Hadley Floating Bridge and approach spans. It is not intended for any other purpose or as the basis for any final design or construction issue associated with this project	Calculation No.:TM-05	
	Rev No.: 0	Sheet 11 of 62



**Figure 3-5: Typical Pile Group**

### 3.6 Material – Elastic Elements

Material properties for elastic elements are summarized in Table 3-4.

**Table 3-4: Material Properties for Elastic Elements**

Material Number	Modulus of Elasticity (ksf)	Density (kcf/g)	Description
1	519120	0.004814	Superstructure $f'_c = 4000$ psi, concrete density = 155 pcf
2	519120	0.004969	Columns $f'_c = 4000$ psi, concrete density = 160 pcf
3	519120	0.0	Rigid elements
4	519120	0.004969	Piles in footing $f'_c = 4000$ psi, concrete density = 160 pcf
5	519120	0.004814	Transverse Beam at Pier 2 $f'_c = 4000$ psi, concrete density = 155 pcf
6	635789	0.004814	Superstructure elements

<b>I-90 Homer Hadley Floating Bridge – LRT Impacts</b>		<b>SC Solutions</b>
<b>Subject/Description: Seismic Vulnerability Assessment of the West Approach and Transition Spans</b>	Originator: Joyce Kin-Yan Lee	Date: 8/6/2008
	Checked: Hassan Sedarat	Date: 8/6/2008
Disclaimer: The analysis in this technical document is preliminary and is strictly to be used as advice in determining the feasibility of placing the LRT on the Homer Hadley Floating Bridge and approach spans. It is not intended for any other purpose or as the basis for any final design or construction issue associated with this project	Calculation No.:TM-05	
	Rev No.: 0	Sheet 12 of 62

			$f'_c = 6000$ psi, concrete density = 160 pcf
7	608722	0.004969	Column elements $f'_c = 5500$ psi, concrete density = 160 pcf
8	4176000	0.015217	Superstructure (composite structure on span 7) Structural steel (490 pcf)
Notes (refer to drawing 277 of 579 and Pg 8-45 of design criteria) Steel mass density= $[490(\text{lb}/\text{ft}^3)/10^3]/32.2(\text{ft}/\text{s}^2)=1.15217\text{E}-7$ k-s <sup>2</sup> /in Concrete mass density= $[155(\text{lb}/\text{ft}^3)/10^3]/32.2(\text{ft}/\text{s}^2)=4.814\text{E}-3$ k-s <sup>2</sup> /ft			

### 3.7 Moment-Curvature Relations – Nonlinear Plastic Elements

#### 3.7.1 General

The rigidities for each pier is computed based on its moment-curvature relations (see Table 3-5). Concrete compressive strength is 5500 psi. The expected factor for concrete is 1.3. The expected steel yield stress is 68 ksi. All bars are ASTM 615 GR-60. Typical steel and concrete properties are shown in Figure 3-6 and Figure 3-7. The cross sections of piers for Lines L and M and the corresponding SPEMC models are shown in Figure 3-8 to Figure 3-31. Typical moment-curvature relation o pier is shown in Figure 3-32.

Subject/Description: **Seismic Vulnerability Assessment of the West Approach and Transition Spans**

Originator: Joyce Kin-Yan Lee

Date: 8/6/2008

Checked: Hassan Sedarat

Date: 8/6/2008

Disclaimer: The analysis in this technical document is preliminary and is strictly to be used as advice in determining the feasibility of placing the LRT on the Homer Hadley Floating Bridge and approach spans. It is not intended for any other purpose or as the basis for any final design or construction issue associated with this project

Calculation No.:TM-05

Rev No.: 0

Sheet 13 of 62

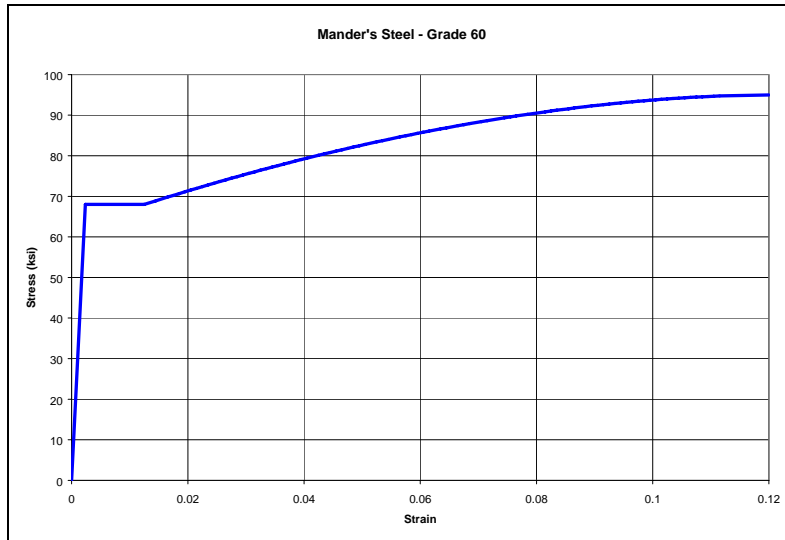


Figure 3-6: Typical Steel Stress-Strain Relation

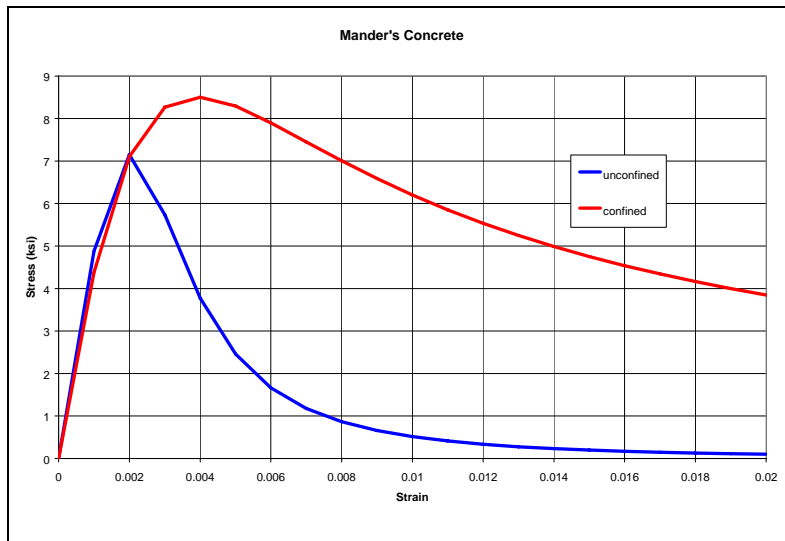


Figure 3-7: Typical Concrete Stress-Strain Relation

<b>I-90 Homer Hadley Floating Bridge – LRT Impacts</b>		<b>SC Solutions</b>
<b>Subject/Description: Seismic Vulnerability Assessment of the West Approach and Transition Spans</b>	Originator: Joyce Kin-Yan Lee	Date: 8/6/2008
	Checked: Hassan Sedarat	Date: 8/6/2008
Disclaimer: The analysis in this technical document is preliminary and is strictly to be used as advice in determining the feasibility of placing the LRT on the Homer Hadley Floating Bridge and approach spans. It is not intended for any other purpose or as the basis for any final design or construction issue associated with this project	Calculation No.:TM-05	
	Rev No.: 0	Sheet 14 of 62

**Table 3-5: Rigidity Numbers -- Piers**

Line	Pier	Filename	section	confinement bar size	spacing	rigidity
LL	1	n/a				
	2	P02LL-1	hollow	6	11.5	21
		P02LL-2	solid	6	4	22
		P02LL-3	solid	6	11.5	23
	3	P03LL-1	splt	6	4	31
		P03LL-2	split	6	11	32
		P03LL-3	solid	6	4.5	33
		P03LL-4	solid	6	11	34
	4	P04LL-1	hollow	7	12	41
		P04LL-2	hollow	7	4	42
		P04LL-3	solid	7	4	43
	5	P05LL-1	hollow	7	10	51
		P05LL-2	hollow	7	4	52
		P05LL-3	solid	7	4	53
	6	P06LL-1	hollow	7	12	61
		P06LL-2	hollow	7	4	62
		P06LL-3	solid	7	4	63
	7	P07LL-1	hollow	6	12	71
		P07LL-2	solid	7	4	72
LM	1					
	2	P02LM-1	solid	7	13	121
		P02LM-2	solid	7	4	122
	3	P03LM-1	split	6	3.5	131
		P03LM-2	solid	6	3.5	132
		P03LM-3	solid		5	133
	4	P04LM-1	hollow	6	8	141
		P04LM-2	solid	7	4	142

<b>I-90 Homer Hadley Floating Bridge – LRT Impacts</b>		<b>SC Solutions</b>
<b>Subject/Description: Seismic Vulnerability Assessment of the West Approach and Transition Spans</b>	Originator: Joyce Kin-Yan Lee	Date: 8/6/2008
	Checked: Hassan Sedarat	Date: 8/6/2008
Disclaimer: The analysis in this technical document is preliminary and is strictly to be used as advice in determining the feasibility of placing the LRT on the Homer Hadley Floating Bridge and approach spans. It is not intended for any other purpose or as the basis for any final design or construction issue associated with this project	Calculation No.:TM-05	
	Rev No.: 0	Sheet 15 of 62

	5	P05LM-1	soild	5	12	151
		P05LM-2	soild	7	4	152
	6	<b>this is identical to 151</b>				161
		<b>this is identical to 152</b>				162
	7	P07LM-1	solid	5	12	171
		P07LM-2	solid	7	4	172

Subject/Description: **Seismic Vulnerability Assessment of the West Approach and Transition Spans**

Originator: Joyce Kin-Yan Lee

Date: 8/6/2008

Checked: Hassan Sedarat

Date: 8/6/2008

Disclaimer: The analysis in this technical document is preliminary and is strictly to be used as advice in determining the feasibility of placing the LRT on the Homer Hadley Floating Bridge and approach spans. It is not intended for any other purpose or as the basis for any final design or construction issue associated with this project

Calculation No.: TM-05

Rev No.: 0

Sheet 16 of 62

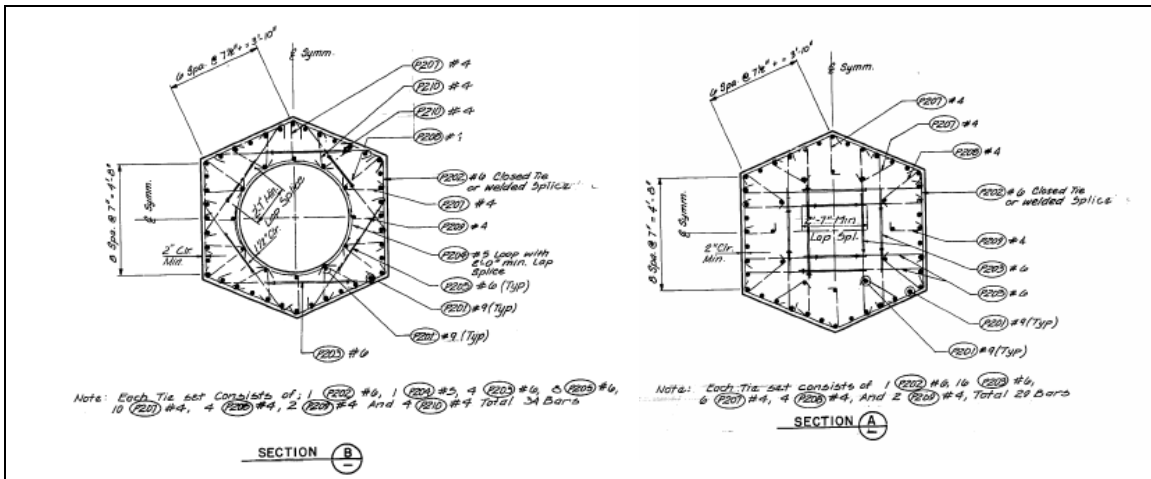


Figure 3-8: LL Pier 2 - drawing 286

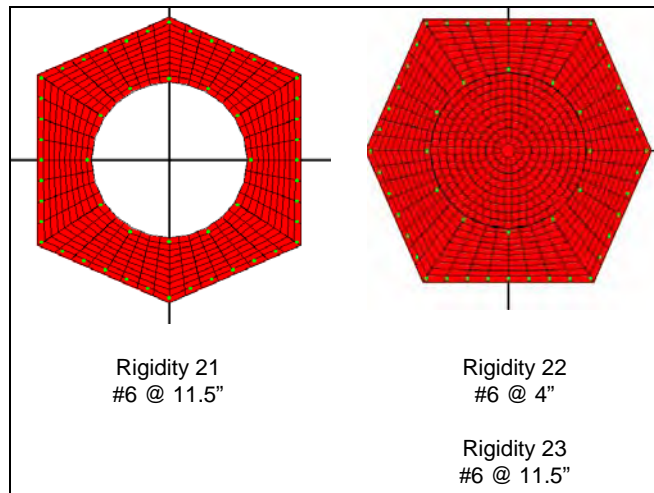


Figure 3-9: LL Pier 2 SPEMC Model

Subject/Description: **Seismic Vulnerability Assessment of the West Approach and Transition Spans**

Originator: Joyce Kin-Yan Lee

Date: 8/6/2008

Checked: Hassan Sedarat

Date: 8/6/2008

Disclaimer: The analysis in this technical document is preliminary and is strictly to be used as advice in determining the feasibility of placing the LRT on the Homer Hadley Floating Bridge and approach spans. It is not intended for any other purpose or as the basis for any final design or construction issue associated with this project

Calculation No.: TM-05

Rev No.: 0

Sheet 17 of 62

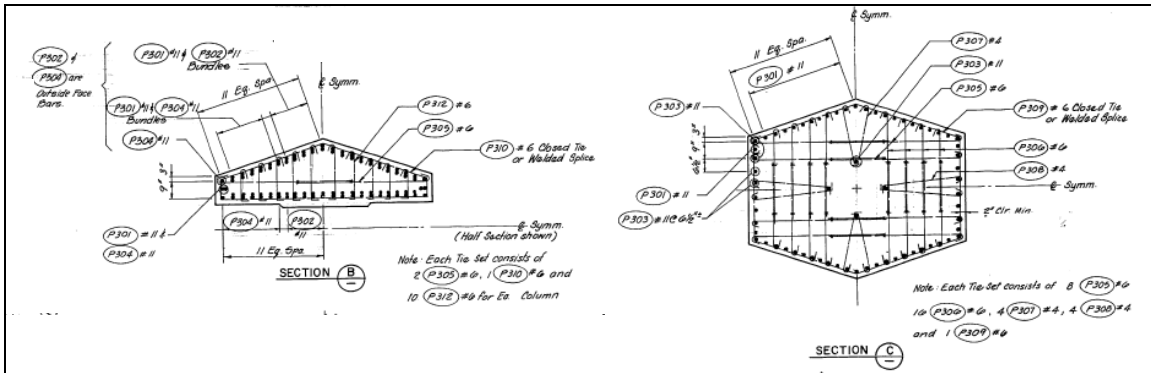


Figure 3-10: LL Pier 3 Transverse View – drawing 289

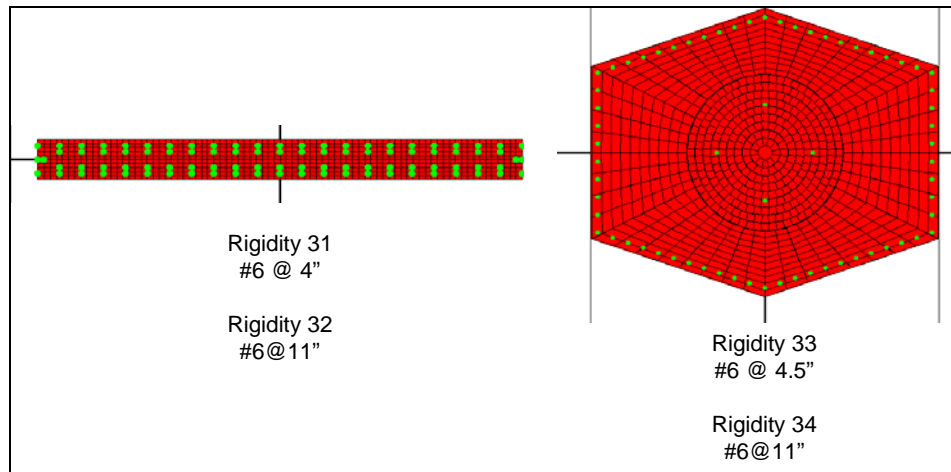


Figure 3-11: LL Pier 3 – SP EMC Model



Subject/Description: **Seismic Vulnerability Assessment of the West Approach and Transition Spans**

Originator: Joyce Kin-Yan Lee

Date: 8/6/2008

Checked: Hassan Sedarat

Date: 8/6/2008

Disclaimer: The analysis in this technical document is preliminary and is strictly to be used as advice in determining the feasibility of placing the LRT on the Homer Hadley Floating Bridge and approach spans. It is not intended for any other purpose or as the basis for any final design or construction issue associated with this project

Calculation No.: TM-05

Rev No.: 0

Sheet 18 of 62

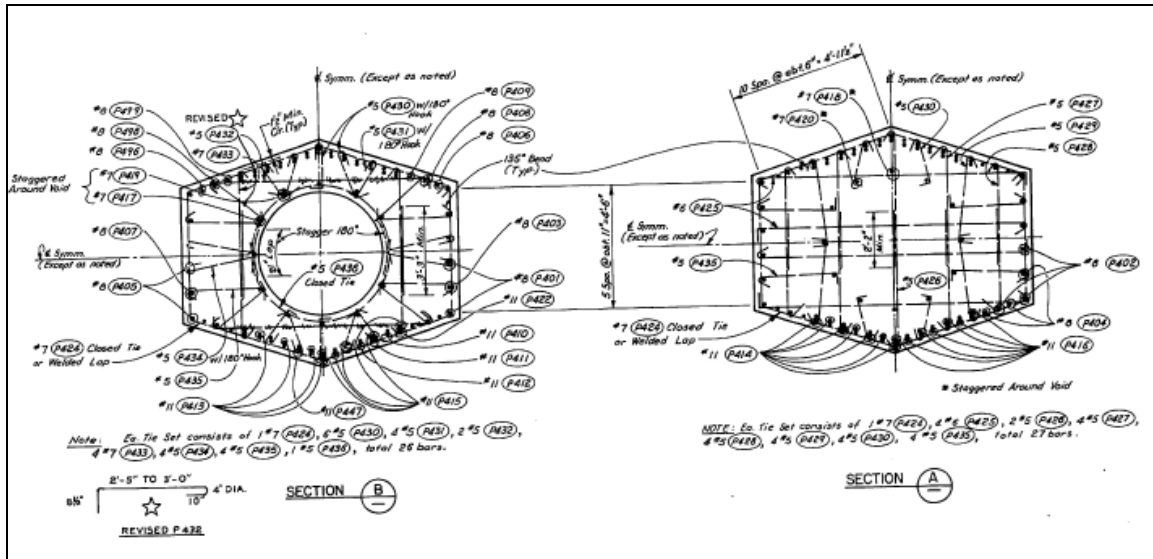


Figure 3-12: LL Pier 4 Column Reinforcement - drawing 292

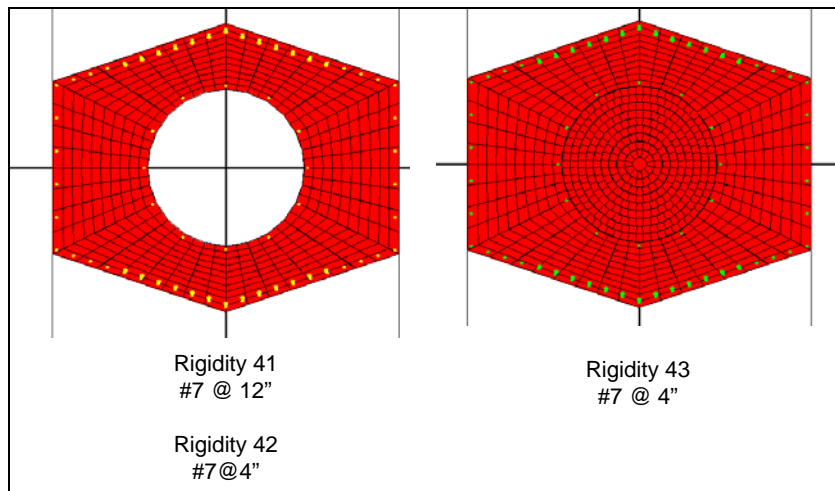


Figure 3-13: LL Pier 4 – SPEMC Model

Subject/Description: **Seismic Vulnerability Assessment of the West Approach and Transition Spans**

Originator: Joyce Kin-Yan Lee

Date: 8/6/2008

Checked: Hassan Sedarat

Date: 8/6/2008

Disclaimer: The analysis in this technical document is preliminary and is strictly to be used as advice in determining the feasibility of placing the LRT on the Homer Hadley Floating Bridge and approach spans. It is not intended for any other purpose or as the basis for any final design or construction issue associated with this project

Calculation No.:TM-05

Rev No.: 0

Sheet 19 of 62

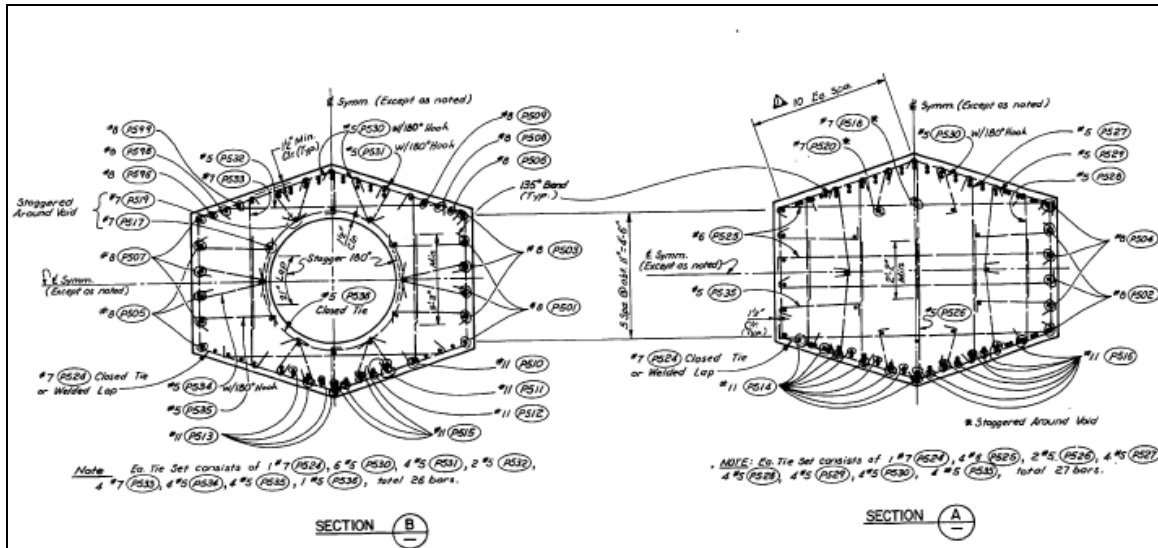


Figure 3-14: LL Pier 5 – drawing 295

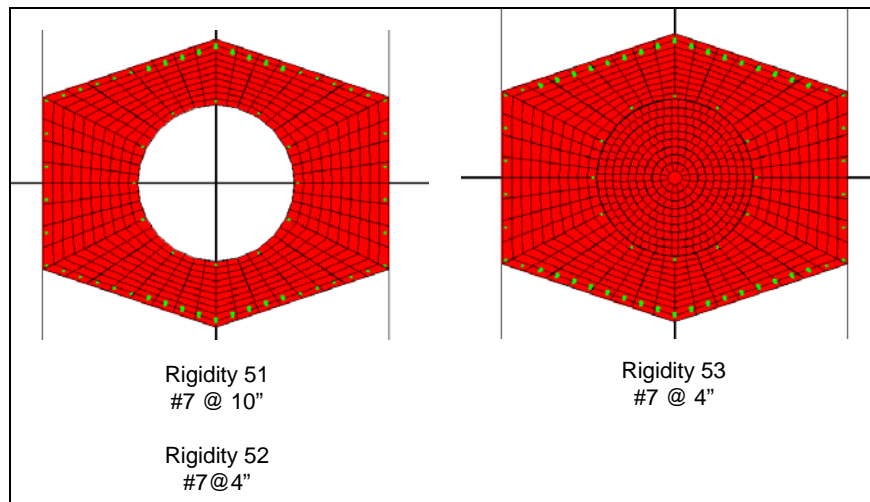


Figure 3-15: LL Pier 5 – SPEMC Model

Subject/Description: **Seismic Vulnerability Assessment of the West Approach and Transition Spans**

Originator: Joyce Kin-Yan Lee

Date: 8/6/2008

Checked: Hassan Sedarat

Date: 8/6/2008

Disclaimer: The analysis in this technical document is preliminary and is strictly to be used as advice in determining the feasibility of placing the LRT on the Homer Hadley Floating Bridge and approach spans. It is not intended for any other purpose or as the basis for any final design or construction issue associated with this project

Calculation No.: TM-05

Rev No.: 0

Sheet 20 of 62

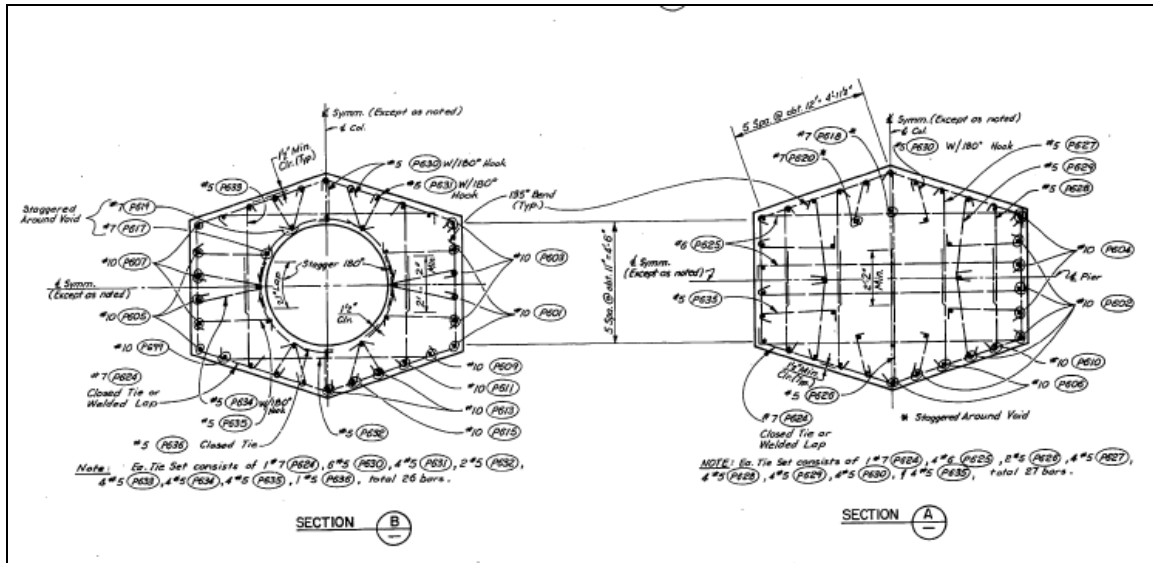


Figure 3-16: LL Pier 6 – drawing 296

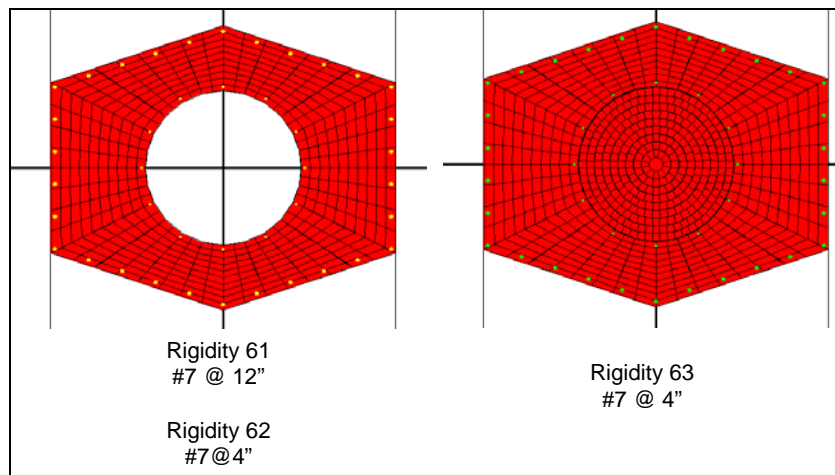


Figure 3-17: LL Pier 6 –SPEMC Model

Subject/Description: **Seismic Vulnerability Assessment of the West Approach and Transition Spans**

Originator: Joyce Kin-Yan Lee

Date: 8/6/2008

Checked: Hassan Sedarat

Date: 8/6/2008

Disclaimer: The analysis in this technical document is preliminary and is strictly to be used as advice in determining the feasibility of placing the LRT on the Homer Hadley Floating Bridge and approach spans. It is not intended for any other purpose or as the basis for any final design or construction issue associated with this project

Calculation No.: TM-05

Rev No.: 0

Sheet 21 of 62

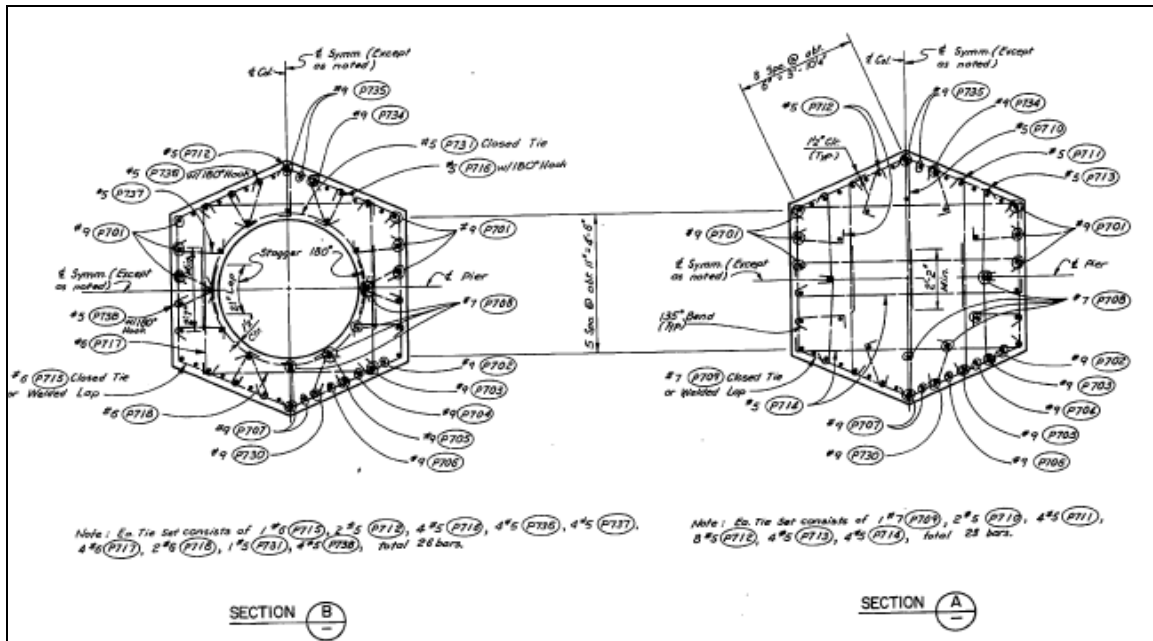


Figure 3-18: LL Pier 7 – drawing 301

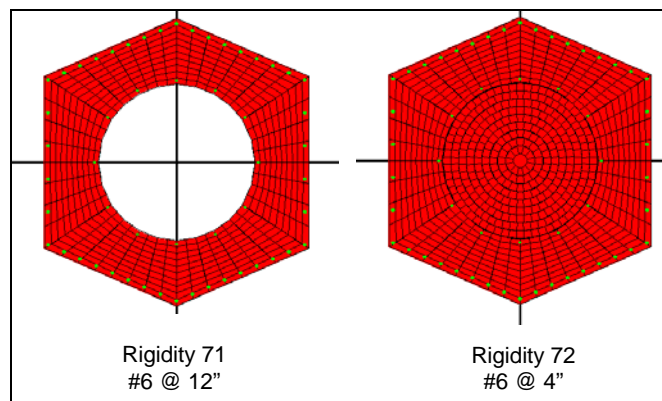


Figure 3-19: LL Pier 7 – SPEMC Model

I-90 Homer Hadley Floating Bridge – LRT Impacts		SC Solutions
Subject/Description: <b>Seismic Vulnerability Assessment of the West Approach and Transition Spans</b>	Originator: Joyce Kin-Yan Lee	Date: 8/6/2008
	Checked: Hassan Sedarat	Date: 8/6/2008
Disclaimer: The analysis in this technical document is preliminary and is strictly to be used as advice in determining the feasibility of placing the LRT on the Homer Hadley Floating Bridge and approach spans. It is not intended for any other purpose or as the basis for any final design or construction issue associated with this project	Calculation No.: TM-05	
	Rev No.: 0	Sheet 22 of 62

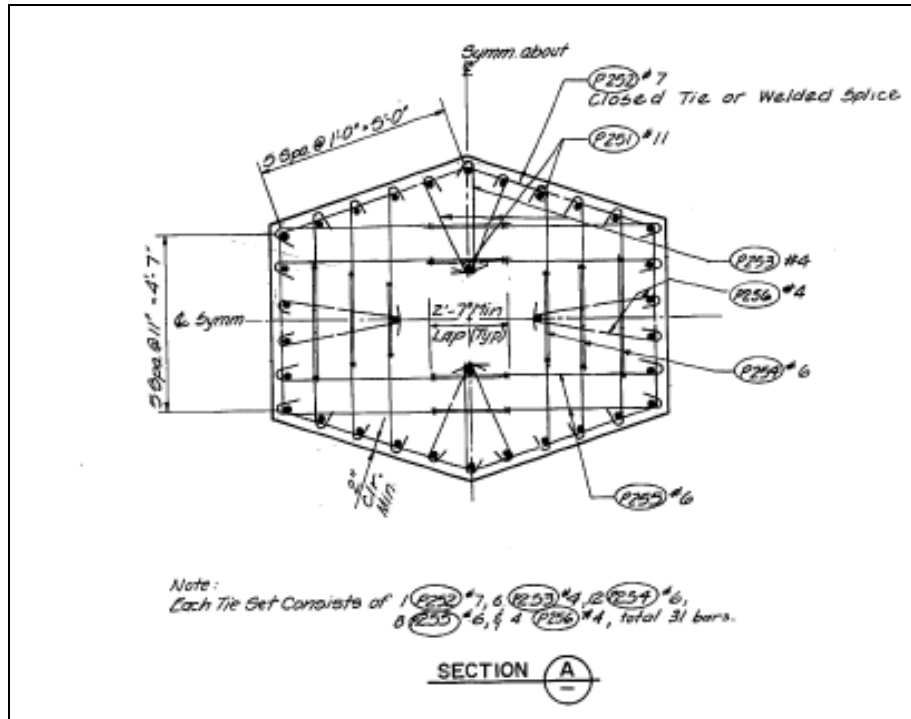


Figure 3-20: LM Pier 2 – drawing 304

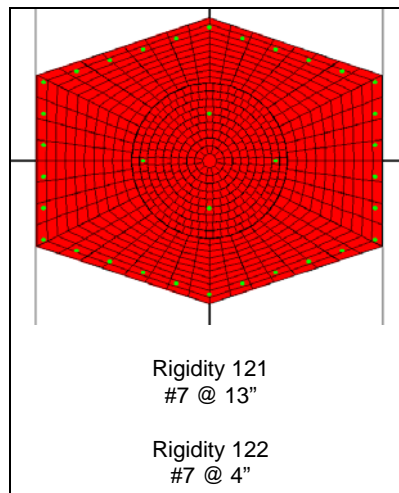


Figure 3-21: LM Pier 2 – SPEMC Model

Subject/Description: **Seismic Vulnerability Assessment of the West Approach and Transition Spans**

Originator: Joyce Kin-Yan Lee

Date: 8/6/2008

Checked: Hassan Sedarat

Date: 8/6/2008

Disclaimer: The analysis in this technical document is preliminary and is strictly to be used as advice in determining the feasibility of placing the LRT on the Homer Hadley Floating Bridge and approach spans. It is not intended for any other purpose or as the basis for any final design or construction issue associated with this project

Calculation No.: TM-05

Rev No.: 0

Sheet 23 of 62

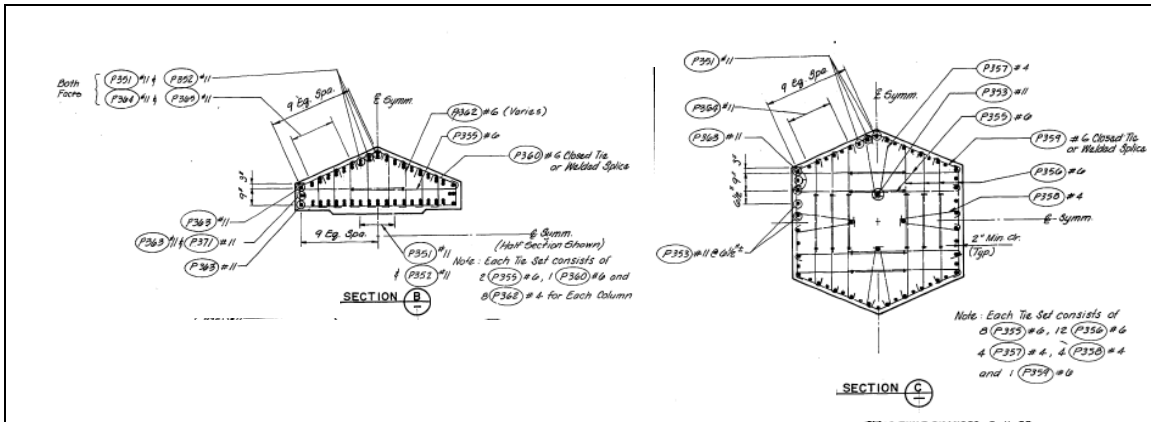


Figure 3-22: LM Pier 3 – drawing 309

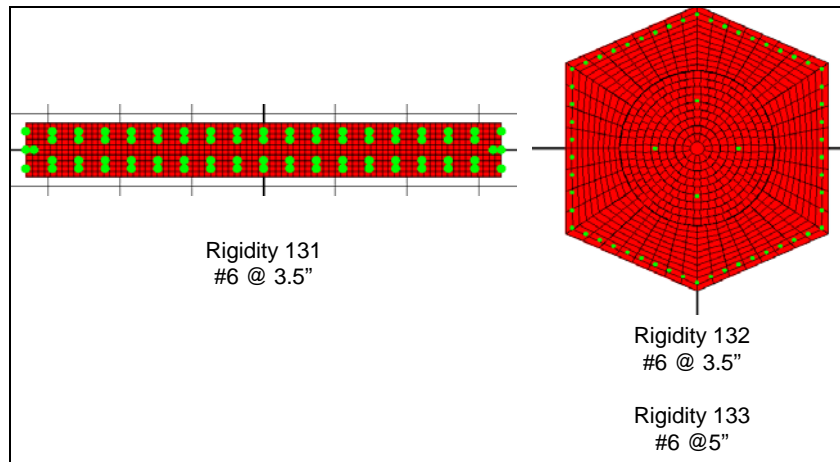


Figure 3-23: LM Pier 3 – SPEMC Model



Subject/Description: **Seismic Vulnerability Assessment of the West Approach and Transition Spans**

Originator: Joyce Kin-Yan Lee

Date: 8/6/2008

Checked: Hassan Sedarat

Date: 8/6/2008

Disclaimer: The analysis in this technical document is preliminary and is strictly to be used as advice in determining the feasibility of placing the LRT on the Homer Hadley Floating Bridge and approach spans. It is not intended for any other purpose or as the basis for any final design or construction issue associated with this project

Calculation No.: TM-05

Rev No.: 0

Sheet 24 of 62

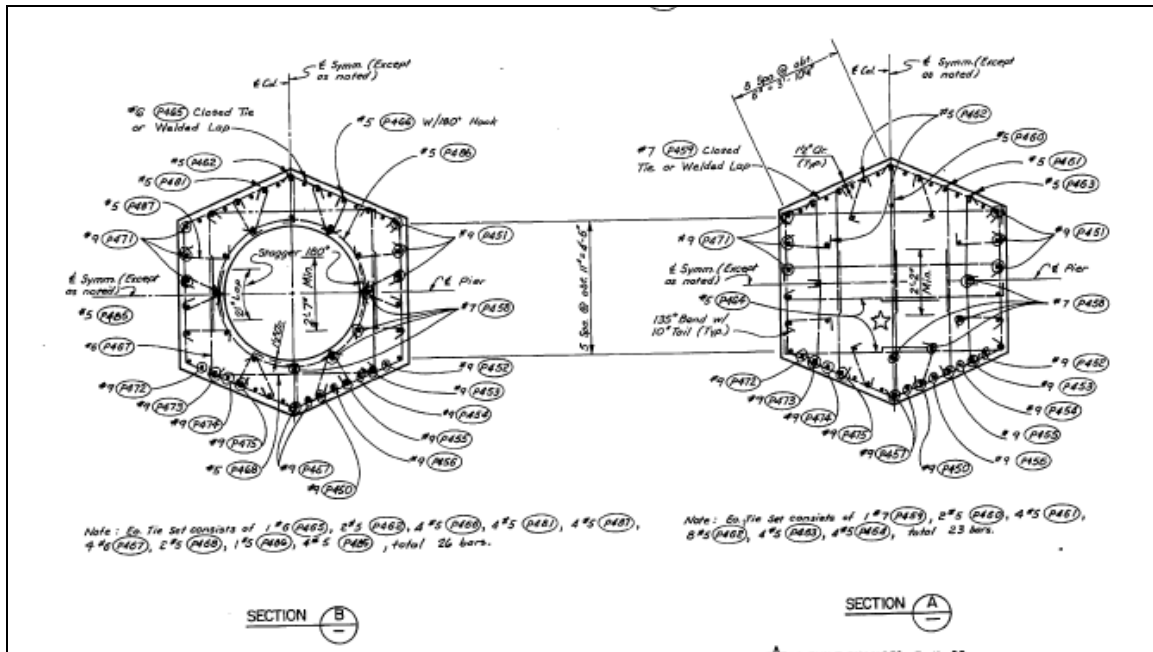


Figure 3-24: LM Pier 4 – drawing 312

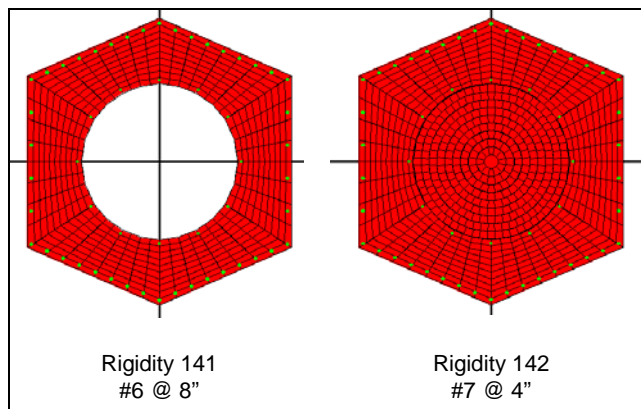
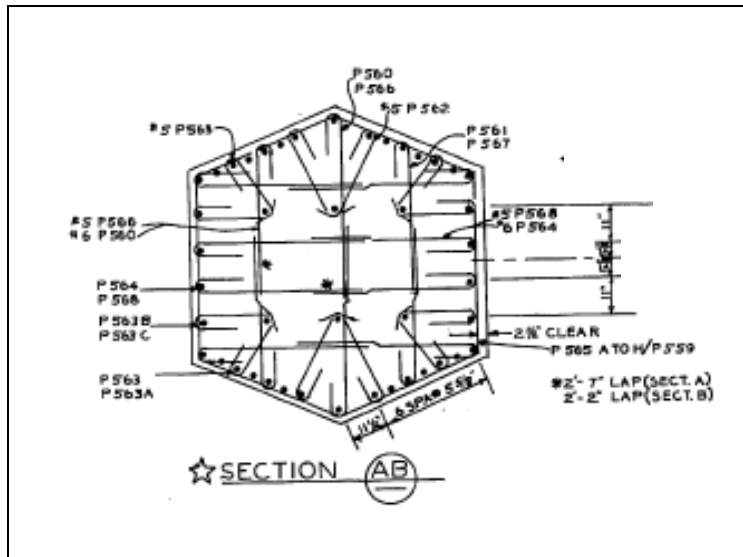
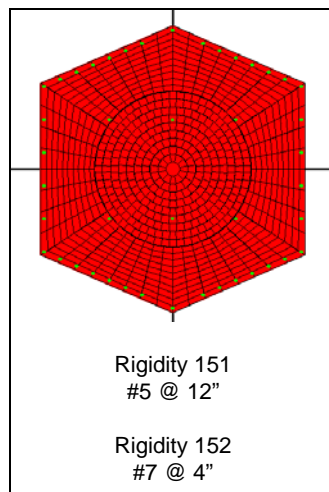


Figure 3-25: LM Pier 4 – SPERC Model

<b>I-90 Homer Hadley Floating Bridge – LRT Impacts</b>		<b>SC Solutions</b>
<b>Subject/Description: Seismic Vulnerability Assessment of the West Approach and Transition Spans</b>	Originator: Joyce Kin-Yan Lee	Date: 8/6/2008
	Checked: Hassan Sedarat	Date: 8/6/2008
Disclaimer: The analysis in this technical document is preliminary and is strictly to be used as advice in determining the feasibility of placing the LRT on the Homer Hadley Floating Bridge and approach spans. It is not intended for any other purpose or as the basis for any final design or construction issue associated with this project	Calculation No.:TM-05	
	Rev No.: 0	Sheet 25 of 62



**Figure 3-26: LM Pier 5 – drawing 315**



**Figure 3-27: LM Pier 5 – SPEMC Model**



Subject/Description: **Seismic Vulnerability Assessment of the West Approach and Transition Spans**

Originator: Joyce Kin-Yan Lee

Date: 8/6/2008

Checked: Hassan Sedarat

Date: 8/6/2008

Disclaimer: The analysis in this technical document is preliminary and is strictly to be used as advice in determining the feasibility of placing the LRT on the Homer Hadley Floating Bridge and approach spans. It is not intended for any other purpose or as the basis for any final design or construction issue associated with this project

Calculation No.: TM-05

Rev No.: 0

Sheet 26 of 62

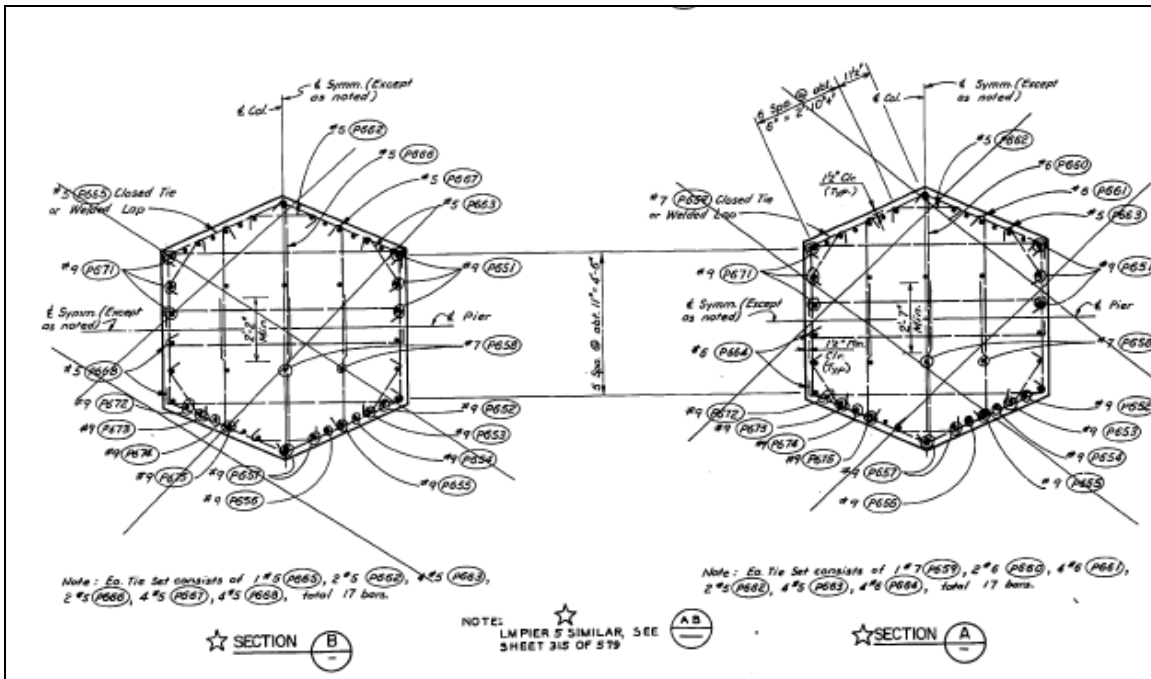


Figure 3-28: LM Pier 6 – drawing 318

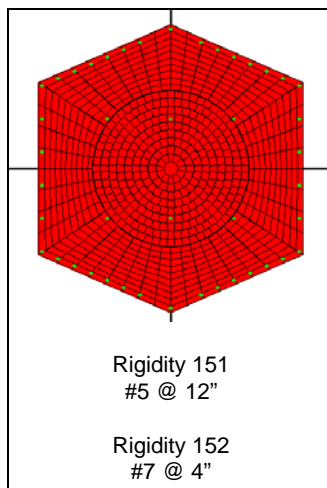


Figure 3-29: LM Pier 6 – SPEMC Model (identical to Pier 5 LM)

Subject/Description: **Seismic Vulnerability Assessment of the West Approach and Transition Spans**

Originator: Joyce Kin-Yan Lee

Date: 8/6/2008

Checked: Hassan Sedarat

Date: 8/6/2008

Disclaimer: The analysis in this technical document is preliminary and is strictly to be used as advice in determining the feasibility of placing the LRT on the Homer Hadley Floating Bridge and approach spans. It is not intended for any other purpose or as the basis for any final design or construction issue associated with this project

Calculation No.: TM-05

Rev No.: 0

Sheet 27 of 62

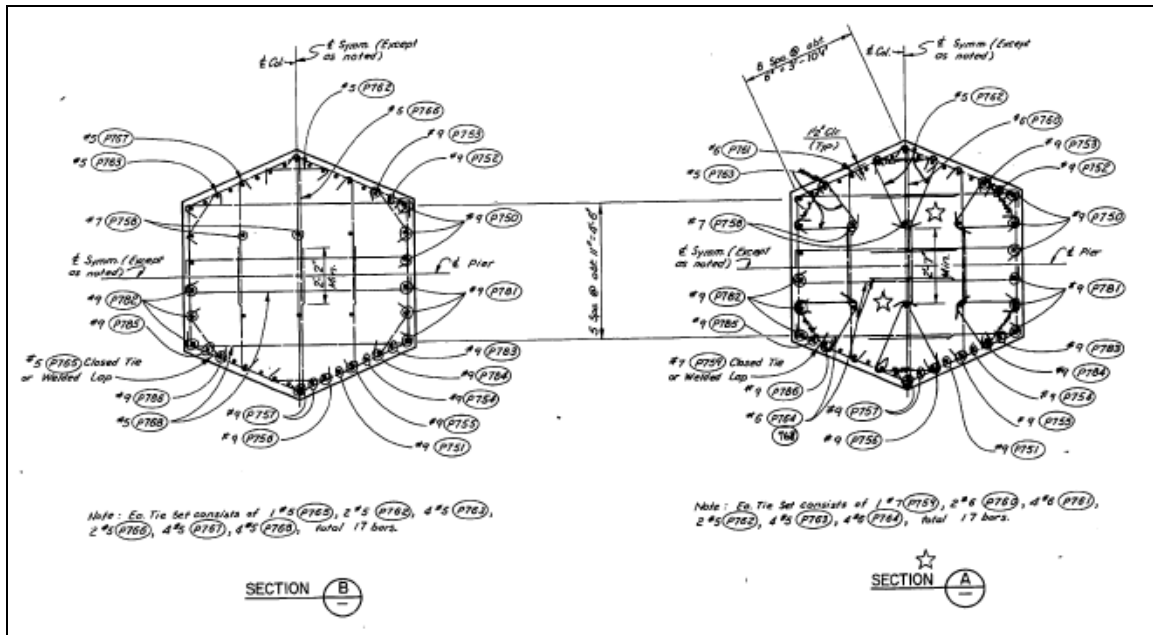


Figure 3-30: LM Pier 7 – drawing 321

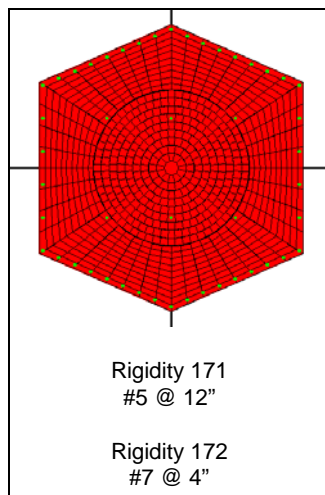
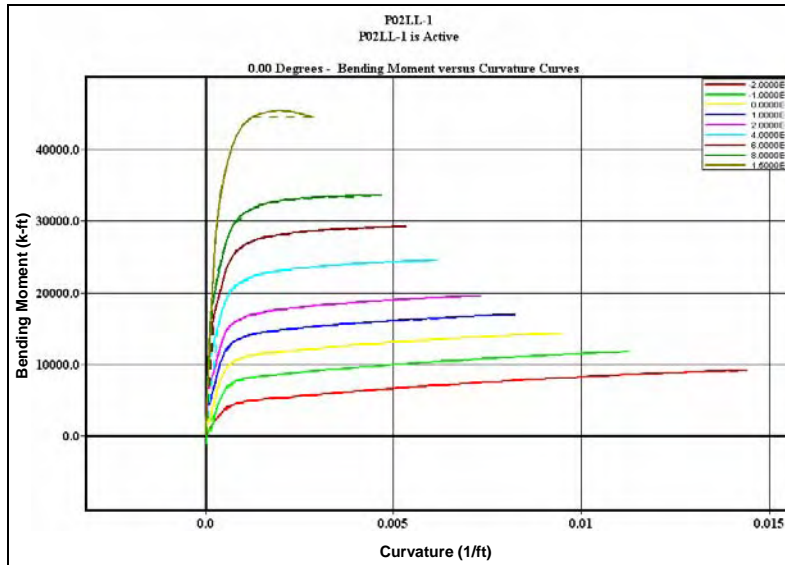


Figure 3-31: LM Pier 7 – SPEMC Model

<b>I-90 Homer Hadley Floating Bridge – LRT Impacts</b>		<b>SC Solutions</b>
<b>Subject/Description: Seismic Vulnerability Assessment of the West Approach and Transition Spans</b>	Originator: Joyce Kin-Yan Lee	Date: 8/6/2008
	Checked: Hassan Sedarat	Date: 8/6/2008
Disclaimer: The analysis in this technical document is preliminary and is strictly to be used as advice in determining the feasibility of placing the LRT on the Homer Hadley Floating Bridge and approach spans. It is not intended for any other purpose or as the basis for any final design or construction issue associated with this project	Calculation No.:TM-05	
	Rev No.: 0	Sheet 28 of 62



**Figure 3-32 Typical Moment-Curvature Relation of Piers**

### 3.8 Elastic Section Properties

Flares for Piers 3 through 7 are modeled with elastic beam elements with variable section properties and are summarized in Table 3-6 below. S-axis is the local transverse axis.

**Table 3-6: Section Properties of Flare Sections at Piers**

Section	Area (ft <sup>2</sup> )	Ir (ft <sup>4</sup> )	Is (ft <sup>4</sup> )	It (ft <sup>4</sup> )	Description
311	25.9951	904.1310	12.9374	891.1936	Pier 3 of line L
321	29.8278	1356.0183	14.8449	1341.1735	Pier 3 of line L
331	33.6606	1939.1466	16.7524	1922.3943	Pier 3 of line L
341	37.4933	2670.3798	18.6599	2651.7199	Pier 3 of line L
411	83.1843	1419.1185	527.9249	891.1936	Pier 4 of line L
421	95.4491	1946.9364	605.7629	1341.1735	Pier 4 of line L
431	107.7139	2605.9952	683.6009	1922.3943	Pier 4 of line L
441	119.9787	3413.1588	761.4389	2651.7199	Pier 4 of line L
511	81.0662	1332.0577	514.4827	817.5749	Pier 5 of line L
521	89.0949	1649.4144	565.4365	1083.9779	Pier 5 of line L
531	97.1236	2019.2663	616.3902	1402.8761	Pier 5 of line L
541	105.1523	2446.3439	667.3440	1778.9999	Pier 5 of line L
611	77.1453	1196.4204	489.5987	706.8217	Pier 6 of line L

I-90 Homer Hadley Floating Bridge – LRT Impacts		SC Solutions
Subject/Description: <b>Seismic Vulnerability Assessment of the West Approach and Transition Spans</b>	Originator: Joyce Kin-Yan Lee	Date: 8/6/2008
	Checked: Hassan Sedarat	Date: 8/6/2008
Disclaimer: The analysis in this technical document is preliminary and is strictly to be used as advice in determining the feasibility of placing the LRT on the Homer Hadley Floating Bridge and approach spans. It is not intended for any other purpose or as the basis for any final design or construction issue associated with this project	Calculation No.:TM-05	
	Rev No.: 0	Sheet 29 of 62

621	86.2942	1534.8870	547.6622	987.2248	Pier 6 of line L
631	95.4432	1939.3776	605.7257	1333.6520	Pier 6 of line L
641	104.5922	2416.8922	663.7891	1753.1031	Pier 6 of line L
711	72.6311	1052.5014	460.9498	591.5516	Pier 7 of line L
721	82.3556	1382.5124	522.6655	859.8469	Pier 7 of line L
731	92.0800	1783.7100	584.3812	1199.3288	Pier 7 of line L
741	101.8044	2264.4999	646.0969	1618.4030	Pier 7 of line L
312	20.5735	454.9068	10.2391	444.6677	Pier 3 of line M
322	24.1695	728.5526	12.0288	716.5238	Pier 3 of line M
332	27.7656	1095.8149	13.8185	1081.9963	Pier 3 of line M
342	31.3617	1570.6222	15.6082	1555.0140	Pier 3 of line M
412	82.3436	1377.3070	522.5898	854.7172	Pier 4 of line M
422	88.9756	1642.2442	564.6793	1077.5649	Pier 4 of line M
432	95.6076	1942.9526	606.7688	1336.1838	Pier 4 of line M
442	102.2396	2282.0984	648.8584	1633.2401	Pier 4 of line M
512	64.6198	827.2644	410.1063	417.1581	Pier 5 of line M
522	73.6967	1084.4229	467.7123	616.7106	Pier 5 of line M
532	82.7736	1397.0820	525.3183	871.7637	Pier 5 of line M
542	91.8504	1772.0775	582.9243	1189.1532	Pier 5 of line M
612	64.6198	827.2644	410.1063	417.1581	Pier 6 of line M
622	73.6967	1084.4229	467.7123	616.7106	Pier 6 of line M
632	82.7736	1397.0820	525.3183	871.7637	Pier 6 of line M
642	91.8504	1772.0775	582.9243	1189.1532	Pier 6 of line M
712	65.9045	864.5571	418.2597	446.2974	Pier 7 of line M
722	77.5508	1214.7238	492.1726	722.5513	Pier 7 of line M
732	89.1972	1661.0387	566.0854	1094.9532	Pier 7 of line M
742	100.8435	2217.9408	639.9983	1577.9425	Pier 7 of line M

Foundation piles are circular concrete sections which are modeled as elastic beam elements. Their section properties are listed in Table 3-7.

**Table 3-7: Section Properties of Piles at Pier Foundations**

Section	Area (ft <sup>2</sup> )	Ir (ft <sup>4</sup> )	Is (ft <sup>4</sup> )	It (ft <sup>4</sup> )	Description
1041	12.5664	25.13274	12.56637	12.5664	4-ft diameter circular piles.
1061	15.9043	40.25779	20.1289	20.1289	4.5-ft diameter circular piles.

I-90 Homer Hadley Floating Bridge – LRT Impacts		SC Solutions
Subject/Description: <b>Seismic Vulnerability Assessment of the West Approach and Transition Spans</b>	Originator: Joyce Kin-Yan Lee	Date: 8/6/2008
	Checked: Hassan Sedarat	Date: 8/6/2008
Disclaimer: The analysis in this technical document is preliminary and is strictly to be used as advice in determining the feasibility of placing the LRT on the Homer Hadley Floating Bridge and approach spans. It is not intended for any other purpose or as the basis for any final design or construction issue associated with this project	Calculation No.:TM-05	
	Rev No.: 0	Sheet 30 of 62

### 3.9 Superstructure Section Properties, and Masses of Superstructure

Figure 3-33 shows a typical superstructure cross-section along line L and line M. Elements in superstructure are discretized based on depth of the girder box as shown in Figure 3-34 which are then assigned with the associated cross-sections. All superstructure cross-sections are summarized in Table 3-8 and Table 3-9.

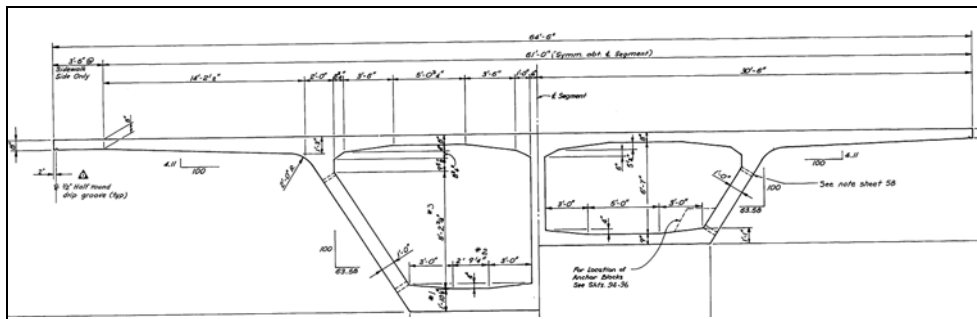


Figure 3-33: Typical Superstructure Cross-Section

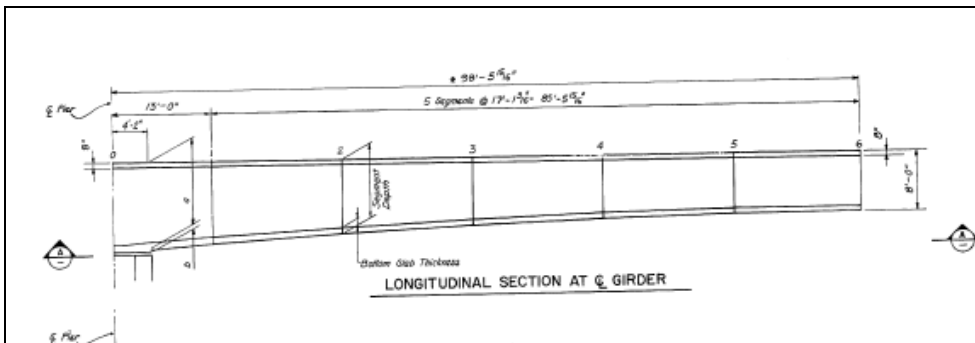


Figure 3-34: Variation in Depth for Cross-Sections along a Typical Span.

Table 3-8: Section Properties of Superstructure Elements on Line L

Section	Area (ft <sup>2</sup> )	Ir (ft <sup>4</sup> )	Is (ft <sup>4</sup> )	It (ft <sup>4</sup> )	Description
101	95.5889	1528.6446	23881.9908	795.9974	Span 1 section with 1' web width.
102	101.0750	1528.6446	23888.0381	825.0506	Span 1 section with 1'-10" web width.
103	95.5889	1528.6446	23881.9908	795.9974	Span 2 section with 1' web width.
104	95.5889	1528.6446	23881.9908	795.9974	Span 2 closure segment.
105	112.5314	3114.2885	24591.4234	2098.6027	Span 3 cantilever variable section 0.
106	109.0985	2756.6148	24491.3526	1745.8065	Span 3 cantilever variable section 1.
107	104.2662	2316.5486	24317.3814	1361.1456	Span 3 cantilever variable section 2.
108	99.5208	1971.8693	24116.9918	1092.1500	Span 3 cantilever variable section 3.

<b>I-90 Homer Hadley Floating Bridge – LRT Impacts</b>		<b>SC Solutions</b>
<b>Subject/Description: Seismic Vulnerability Assessment of the West Approach and Transition Spans</b>	Originator: Joyce Kin-Yan Lee	Date: 8/6/2008
	Checked: Hassan Sedarat	Date: 8/6/2008
Disclaimer: The analysis in this technical document is preliminary and is strictly to be used as advice in determining the feasibility of placing the LRT on the Homer Hadley Floating Bridge and approach spans. It is not intended for any other purpose or as the basis for any final design or construction issue associated with this project	Calculation No.:TM-05	
	Rev No.: 0	Sheet 31 of 62

109	102.6227	1724.4853	23975.4669	956.5363	Span 3 cantilever variable section 4.
110	101.4884	1580.4436	23912.6875	859.0640	Span 3 cantilever variable section 5.
111	101.0750	1528.6446	23888.0381	825.0506	Span 3 cantilever variable section 6.
112	129.4048	3542.7001	24796.3558	2865.7805	Span 4 cantilever variable section 0.
113	122.8405	3168.7588	24756.6687	2311.5997	Span 4 cantilever variable section 1.
114	112.5720	2667.3226	24563.7485	1709.3837	Span 4 cantilever variable section 2.
115	104.9319	2194.2988	24321.8123	1276.8901	Span 4 cantilever variable section 3.
116	98.5600	1830.0937	24056.7138	994.8257	Span 4 cantilever variable section 4.
117	101.7095	1608.3135	23925.2914	877.6252	Span 4 cantilever variable section 5.
118	101.0750	1528.6446	23888.0381	825.0506	Span 4 cantilever variable section 6.
119	138.3028	3237.7139	24867.3379	2641.0877	Span 5 cantilever variable section 0.
120	130.5971	2954.9926	24869.2400	2184.4344	Span 5 cantilever variable section 1.
121	118.4294	2563.1385	24695.8753	1673.0563	Span 5 cantilever variable section 2.
122	112.5347	2107.2855	24544.7207	1256.4218	Span 5 cantilever variable section 3.
123	108.7432	1759.6001	24406.1782	986.4327	Span 5 cantilever variable section 4.
124	106.3475	1599.3777	24105.5521	881.3840	Span 5 cantilever variable section 5.
125	101.0750	1528.6446	23888.0381	825.0506	Span 5 cantilever variable section 6.
126	95.5889	1528.6446	23881.9908	795.9974	Constant section with 1' web width.

**Table 3-9: Section Properties of Superstructure Elements on Line M**

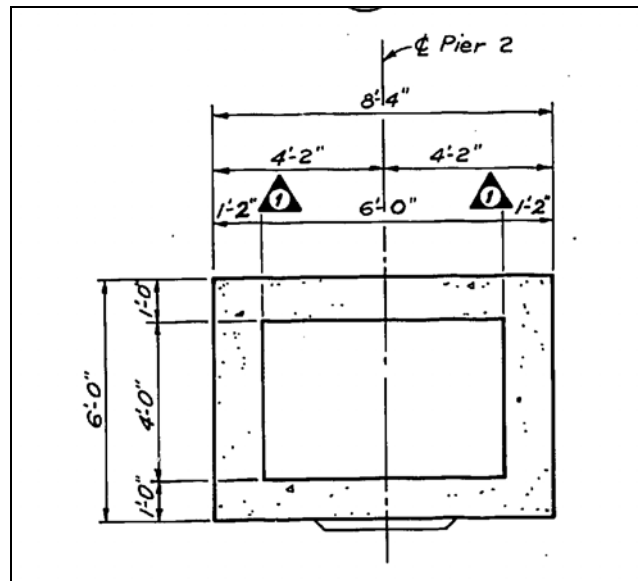
Section	Area (ft <sup>2</sup> )	Ir (ft <sup>4</sup> )	Is (ft <sup>4</sup> )	It (ft <sup>4</sup> )	Description
201	64.6569	1139.9705	7704.5922	565.2699	Span 1 section with 1' web width.
202	71.7328	1220.7080	8540.5298	599.4133	Span 1 section with 1'-6" web width.
203	64.6569	1139.9705	7704.5922	565.2699	Span 2 section with 1' web width.
204	64.6569	1139.9705	7704.5922	565.2699	Span 2 closure segment.
205	73.9504	2391.2415	8190.1284	1491.2549	Span 3 cantilever variable section 0.
206	71.5740	2095.8170	8096.4023	1234.1168	Span 3 cantilever variable section 1.
207	68.4896	1739.6507	7962.0234	957.4790	Span 3 cantilever variable section 2.
208	66.2805	1471.4114	7847.6967	771.3082	Span 3 cantilever variable section 3.
209	65.3947	1288.0287	7771.3807	654.9235	Span 3 cantilever variable section 4.
210	64.8516	1178.7286	7722.3507	588.4083	Span 3 cantilever variable section 5.
211	64.6569	1139.9705	7704.5922	565.2699	Span 3 cantilever variable section 6.
212	89.0488	2841.0824	8407.7729	2127.7238	Span 4 cantilever variable section 0.
213	82.9698	2503.6911	8311.1168	1694.6524	Span 4 cantilever variable section 1.
214	75.3195	2048.0978	8135.8033	1227.1892	Span 4 cantilever variable section 2.
215	69.5883	1654.6852	7954.9271	905.0632	Span 4 cantilever variable section 3.
216	66.2837	1366.6817	7812.6793	705.7437	Span 4 cantilever variable section 4.

<b>I-90 Homer Hadley Floating Bridge – LRT Impacts</b>		<b>SC Solutions</b>
<b>Subject/Description: Seismic Vulnerability Assessment of the West Approach and Transition Spans</b>	Originator: Joyce Kin-Yan Lee	Date: 8/6/2008
	Checked: Hassan Sedarat	Date: 8/6/2008
Disclaimer: The analysis in this technical document is preliminary and is strictly to be used as advice in determining the feasibility of placing the LRT on the Homer Hadley Floating Bridge and approach spans. It is not intended for any other purpose or as the basis for any final design or construction issue associated with this project	Calculation No.:TM-05	
	Rev No.: 0	Sheet 32 of 62

217	64.9529	1199.4536	7731.0809	600.9865	Span 4 cantilever variable section 5.
218	64.6569	1139.9705	7704.5922	565.2699	Span 4 cantilever variable section 6.
219	89.0488	2841.0824	8407.7729	2127.7238	Span 5 cantilever variable section 0.
220	82.9698	2503.6911	8311.1168	1694.6524	Span 5 cantilever variable section 1.
221	75.3195	2048.0978	8135.8033	1227.1892	Span 5 cantilever variable section 2.
222	69.5883	1654.6852	7954.9271	905.0632	Span 5 cantilever variable section 3.
223	66.2837	1366.6817	7812.6793	705.7437	Span 5 cantilever variable section 4.
224	68.8578	1195.8480	7809.7366	606.3312	Span 5 cantilever variable section 5.
225	64.6569	1139.9705	7704.5922	565.2699	Span 5 cantilever variable section 6.
226	64.6569	1139.9705	7704.5922	565.2699	Constant section with 1' web width.

In this model, superstructure was modeled as massless beam elements where translational masses were lumped at the centroids and the edges of the cross sections as shown in Figure 3-4.

### 3.10 Transverse Beam Section at Pier 2



**Figure 3-35: Transverse beam at Pier 2**

Transverse beam elements which connects superstructure to the south column at Pier 2 are modeled as elastic beam elements with properties summarized in Table 3-10.

<b>I-90 Homer Hadley Floating Bridge – LRT Impacts</b>		<b>SC Solutions</b>
<b>Subject/Description: Seismic Vulnerability Assessment of the West Approach and Transition Spans</b>	Originator: Joyce Kin-Yan Lee	Date: 8/6/2008
	Checked: Hassan Sedarat	Date: 8/6/2008
Disclaimer: The analysis in this technical document is preliminary and is strictly to be used as advice in determining the feasibility of placing the LRT on the Homer Hadley Floating Bridge and approach spans. It is not intended for any other purpose or as the basis for any final design or construction issue associated with this project	Calculation No.:TM-05	
	Rev No.: 0	Sheet 33 of 62

**Table 3-10: Section Properties of Transverse Beam**

Section	Area (ft <sup>2</sup> )	Ir (ft <sup>4</sup> )	Is (ft <sup>4</sup> )	It (ft <sup>4</sup> )	Description
1021	26.0000	224.2377	217.3519	118.0000	t-axis is transverse axis.

### 3.11 Mode Shapes and Frequencies

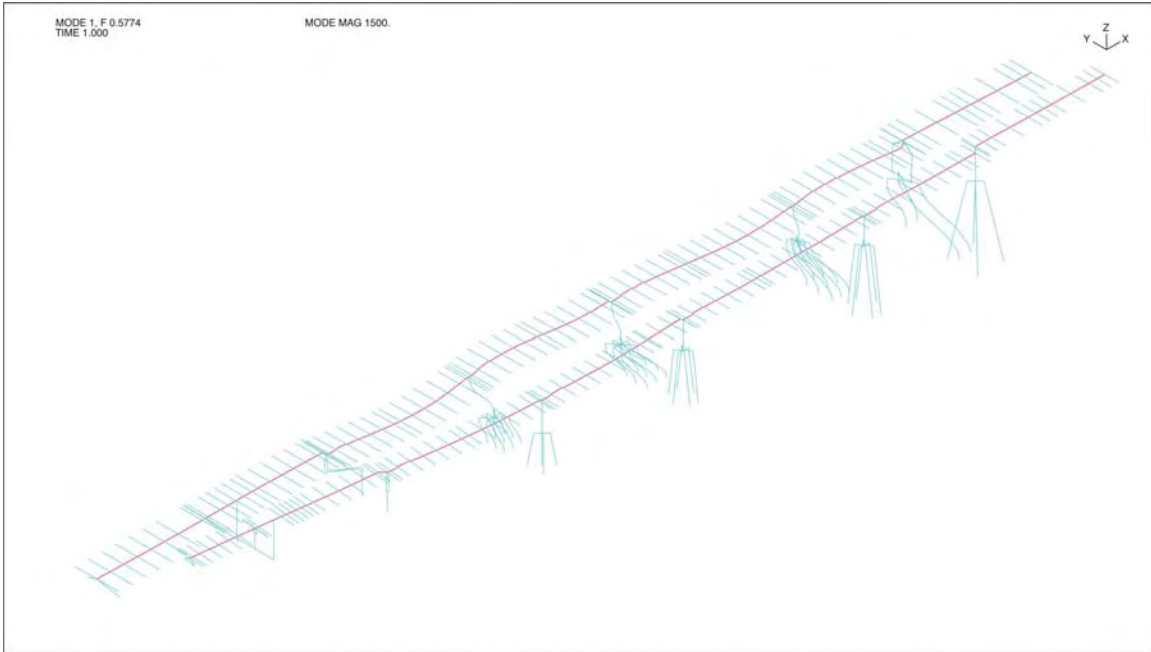
The first 200 modes of the structure were extracted. The frequency analysis was performed for the case in which the point of fixity is at 2.5d below the mud line. The frequencies and effective modal mass participation factors for the first 10 modes are summarized in Table 3-11. About 90% of the mass is captured using 200modes (see Table 3-11). The first 10 mode shapes are shown in Figure 3-36 to Figure 3-45.

**Table 3-11: Period and Effective Modal Mass Participation Factor**

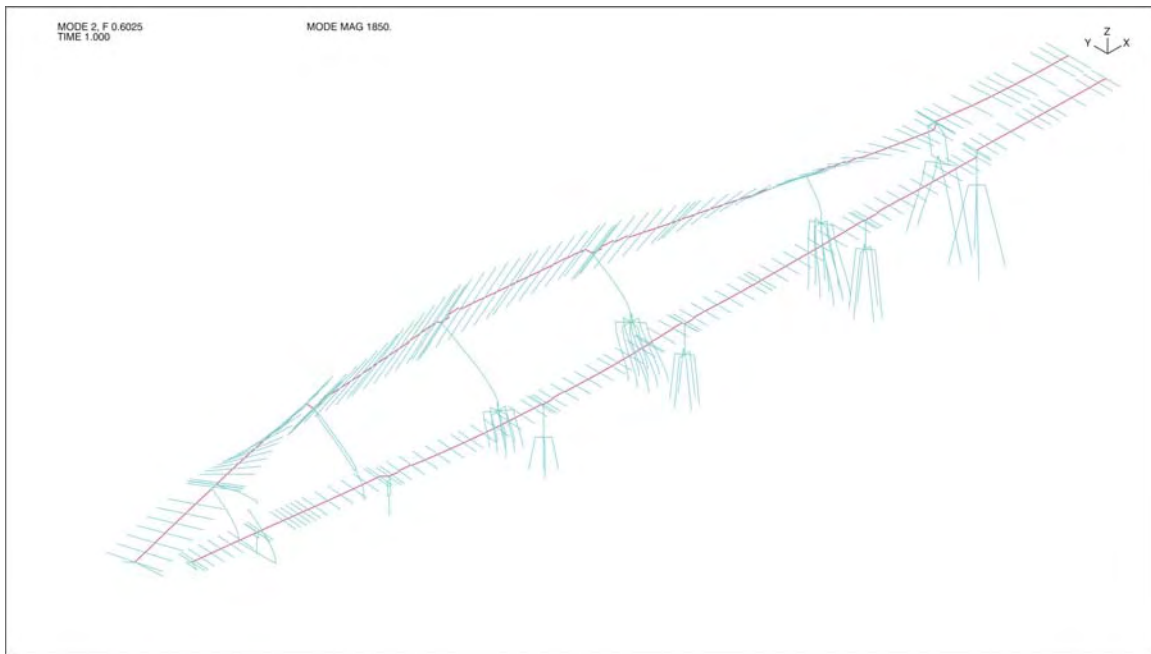
Mode	Frequency (Hz)	Period (sec)	Effective Modal Mass			Accumulative Modal Mass		
			long.	trans.	vert.	long.	trans.	vert.
1	0.5774	1.7320	49.45%	0.00%	0.00%	49.45%	0.00%	0.00%
2	0.6025	1.6597	0.00%	31.73%	0.00%	49.45%	31.73%	0.00%
3	0.8213	1.2176	1.05%	22.43%	0.00%	50.50%	54.16%	0.00%
4	0.8559	1.1683	38.81%	0.38%	0.00%	89.31%	54.54%	0.00%
5	0.9347	1.0699	0.00%	1.09%	0.00%	89.31%	55.63%	0.00%
6	1.0517	0.9508	0.01%	0.22%	0.12%	89.32%	55.85%	0.12%
7	1.0658	0.9383	0.32%	0.03%	0.81%	89.64%	55.88%	0.93%
8	1.0696	0.9349	0.08%	0.01%	1.35%	89.72%	55.89%	2.29%
9	1.2545	0.7971	0.00%	8.28%	0.00%	89.72%	64.17%	2.29%
10	1.2811	0.7806	0.02%	5.75%	0.00%	89.74%	69.92%	2.29%
100	10.0322	0.0997	0.00%	0.00%	0.35%	92.84%	84.68%	60.12%
200	22.0976	0.0453	0.00%	0.00%	0.00%	93.13%	86.32%	80.34%



<b>I-90 Homer Hadley Floating Bridge – LRT Impacts</b>		<b>SC Solutions</b>
<b>Subject/Description: Seismic Vulnerability Assessment of the West Approach and Transition Spans</b>	Originator: Joyce Kin-Yan Lee	Date: 8/6/2008
	Checked: Hassan Sedarat	Date: 8/6/2008
Disclaimer: The analysis in this technical document is preliminary and is strictly to be used as advice in determining the feasibility of placing the LRT on the Homer Hadley Floating Bridge and approach spans. It is not intended for any other purpose or as the basis for any final design or construction issue associated with this project	Calculation No.:TM-05	
	Rev No.: 0	Sheet 34 of 62

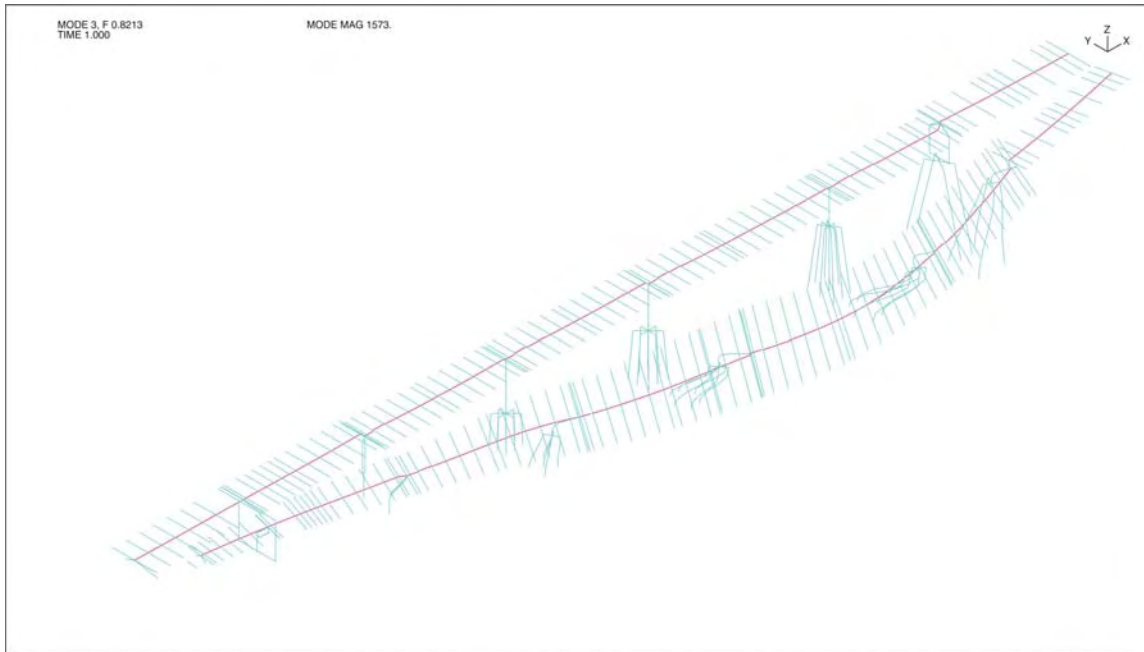


**Figure 3-36: Mode Shape 1 (Longitudinal Line L – Period = 1.73)**

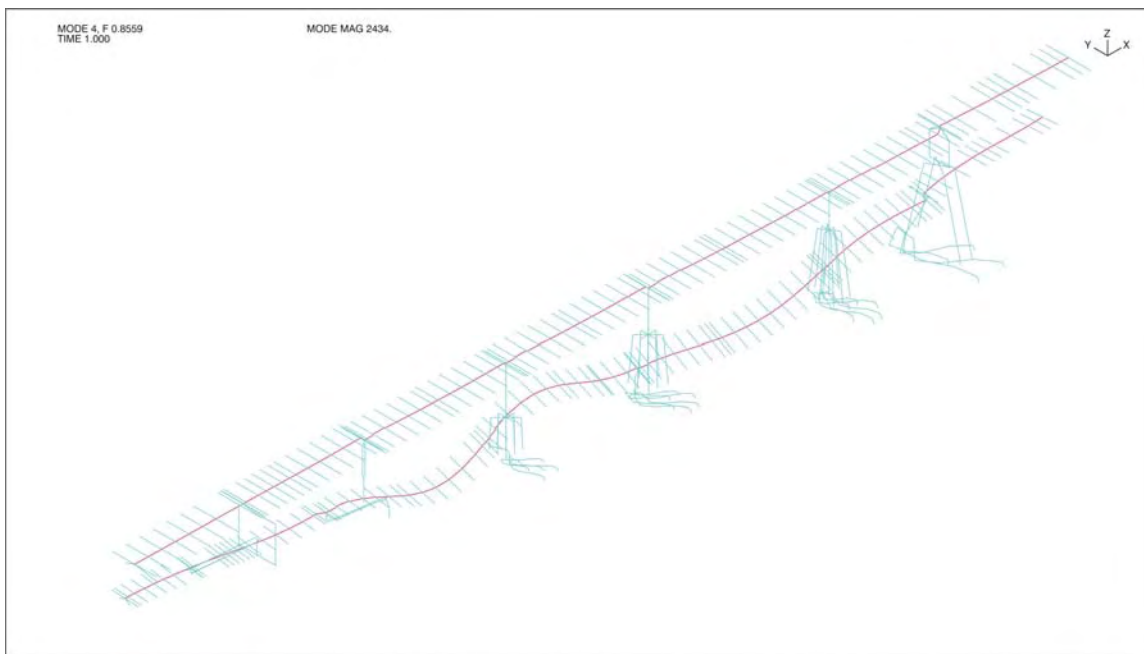


**Figure 3-37: Mode Shape 2 (Transverse Line L – Period = 1.66 sec)**

<b>I-90 Homer Hadley Floating Bridge – LRT Impacts</b>		<b>SC Solutions</b>
<b>Subject/Description: Seismic Vulnerability Assessment of the West Approach and Transition Spans</b>	Originator: Joyce Kin-Yan Lee	Date: 8/6/2008
	Checked: Hassan Sedarat	Date: 8/6/2008
Disclaimer: The analysis in this technical document is preliminary and is strictly to be used as advice in determining the feasibility of placing the LRT on the Homer Hadley Floating Bridge and approach spans. It is not intended for any other purpose or as the basis for any final design or construction issue associated with this project	Calculation No.:TM-05	
	Rev No.: 0	Sheet 35 of 62

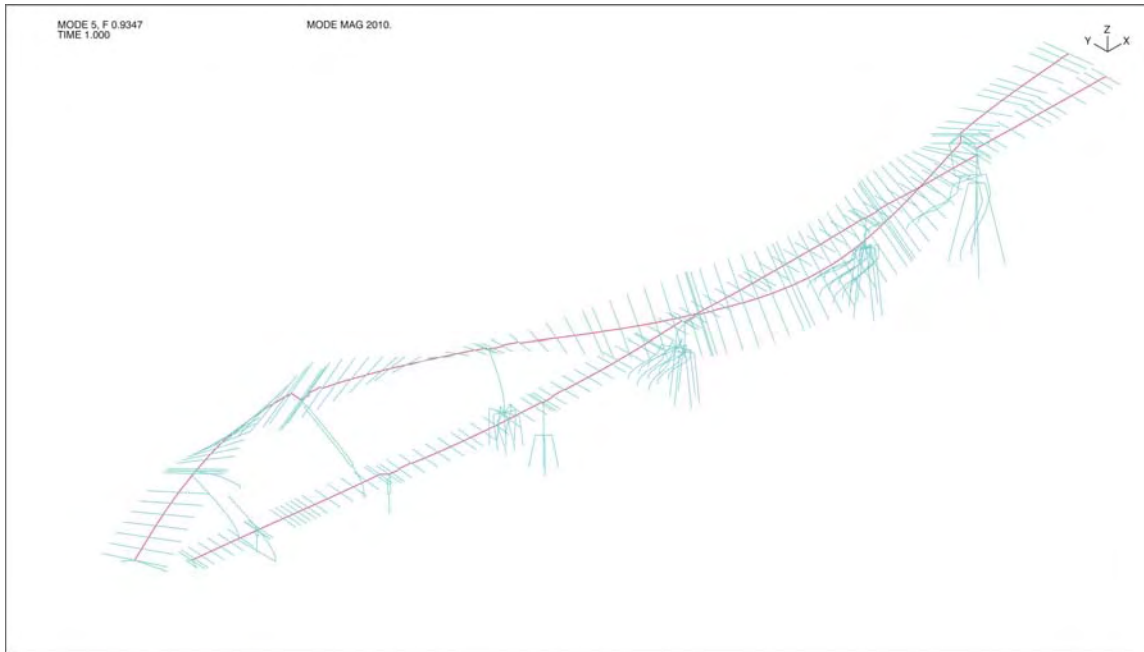


**Figure 3-38: Mode Shape 3 (Transverse Line M – Period = 1.22 sec)**

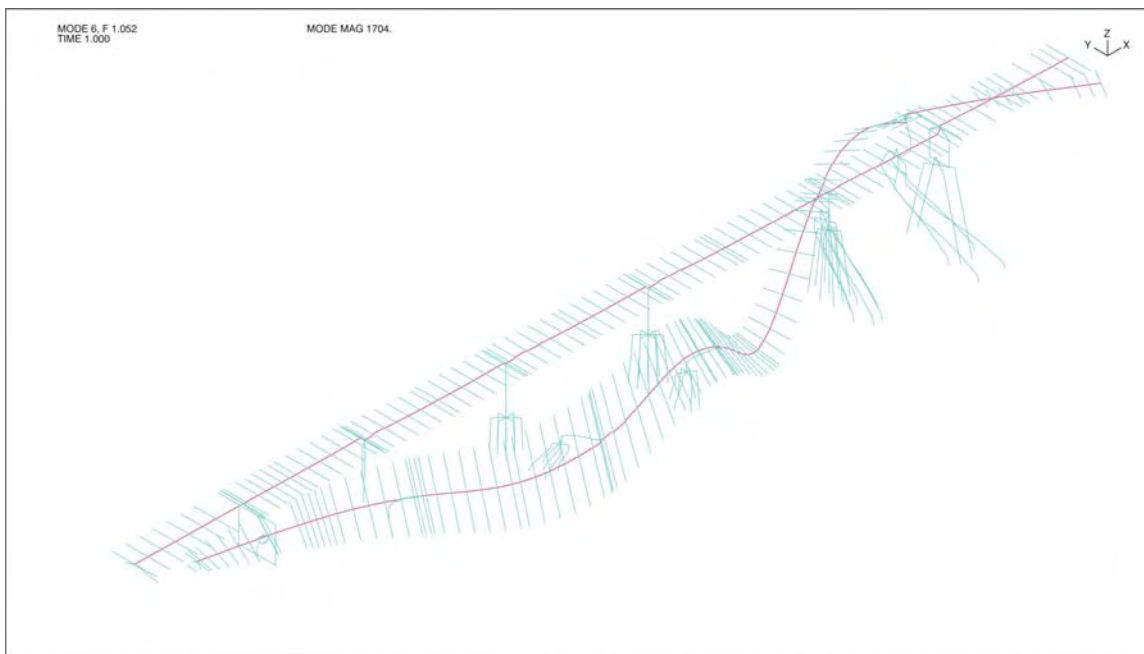


**Figure 3-39: Mode Shape 4 (Longitudinal Line M -- Period = 1.17 sec)**

<b>I-90 Homer Hadley Floating Bridge – LRT Impacts</b>		<b>SC Solutions</b>
<b>Subject/Description: Seismic Vulnerability Assessment of the West Approach and Transition Spans</b>	Originator: Joyce Kin-Yan Lee	Date: 8/6/2008
	Checked: Hassan Sedarat	Date: 8/6/2008
Disclaimer: The analysis in this technical document is preliminary and is strictly to be used as advice in determining the feasibility of placing the LRT on the Homer Hadley Floating Bridge and approach spans. It is not intended for any other purpose or as the basis for any final design or construction issue associated with this project	Calculation No.:TM-05	
	Rev No.: 0	Sheet 36 of 62

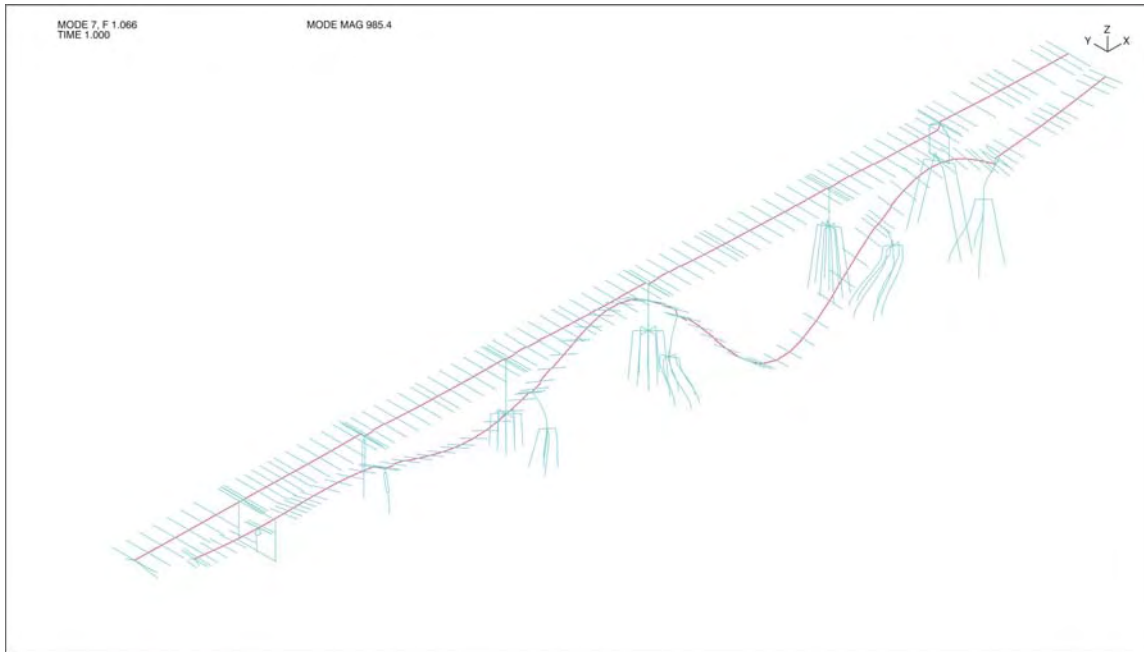


**Figure 3-40: Mode Shape 5 (Transverse Line L – Period = 1.07 sec)**

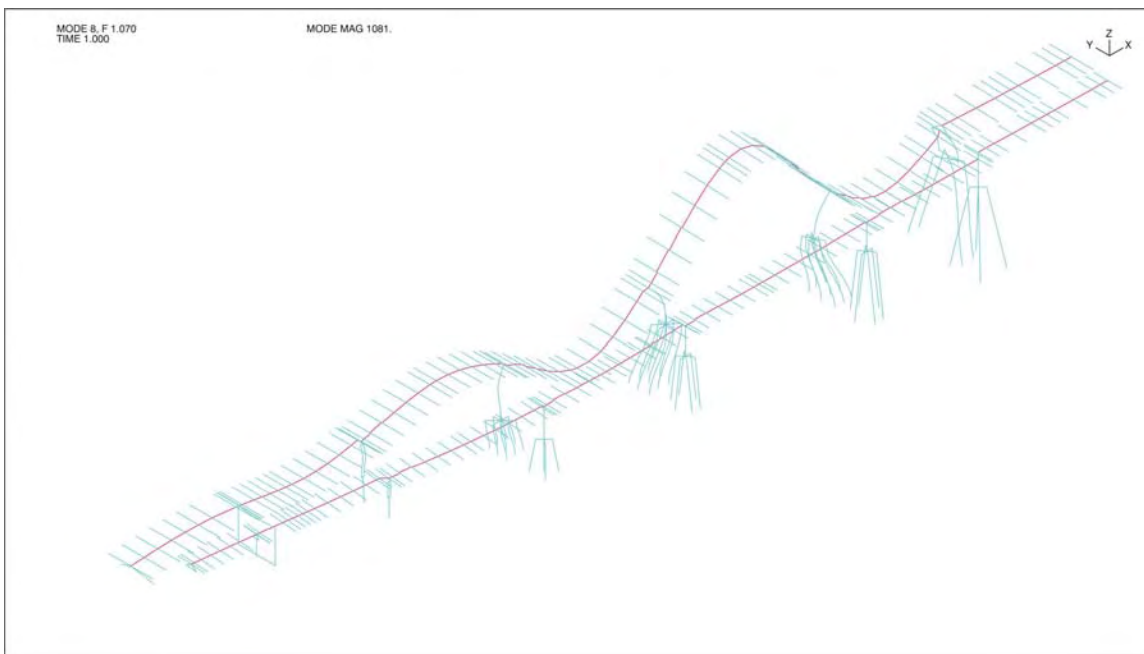


**Figure 3-41: Mode Shape 6 (Vertical Line L – Period = 0.95 sec)**

<b>I-90 Homer Hadley Floating Bridge – LRT Impacts</b>		<b>SC Solutions</b>
<b>Subject/Description: Seismic Vulnerability Assessment of the West Approach and Transition Spans</b>	Originator: Joyce Kin-Yan Lee	Date: 8/6/2008
	Checked: Hassan Sedarat	Date: 8/6/2008
Disclaimer: The analysis in this technical document is preliminary and is strictly to be used as advice in determining the feasibility of placing the LRT on the Homer Hadley Floating Bridge and approach spans. It is not intended for any other purpose or as the basis for any final design or construction issue associated with this project	Calculation No.:TM-05	
	Rev No.: 0	Sheet 37 of 62

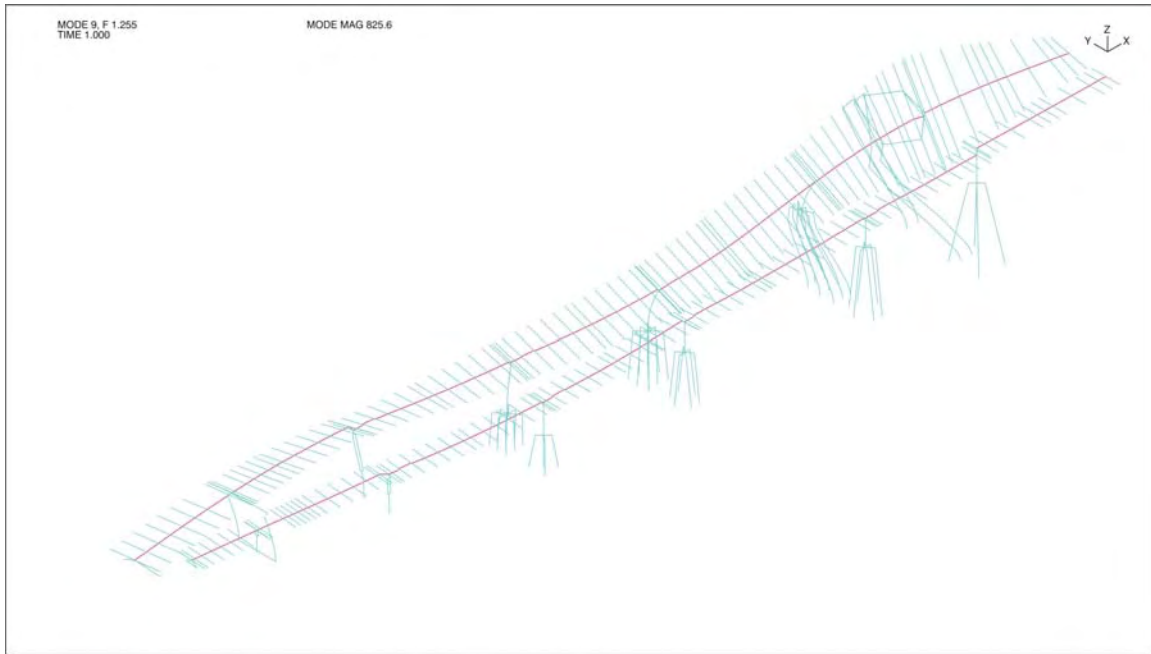


**Figure 3-42: Mode Shape 7 (Vertical Line M – Period = 0.94 sec)**

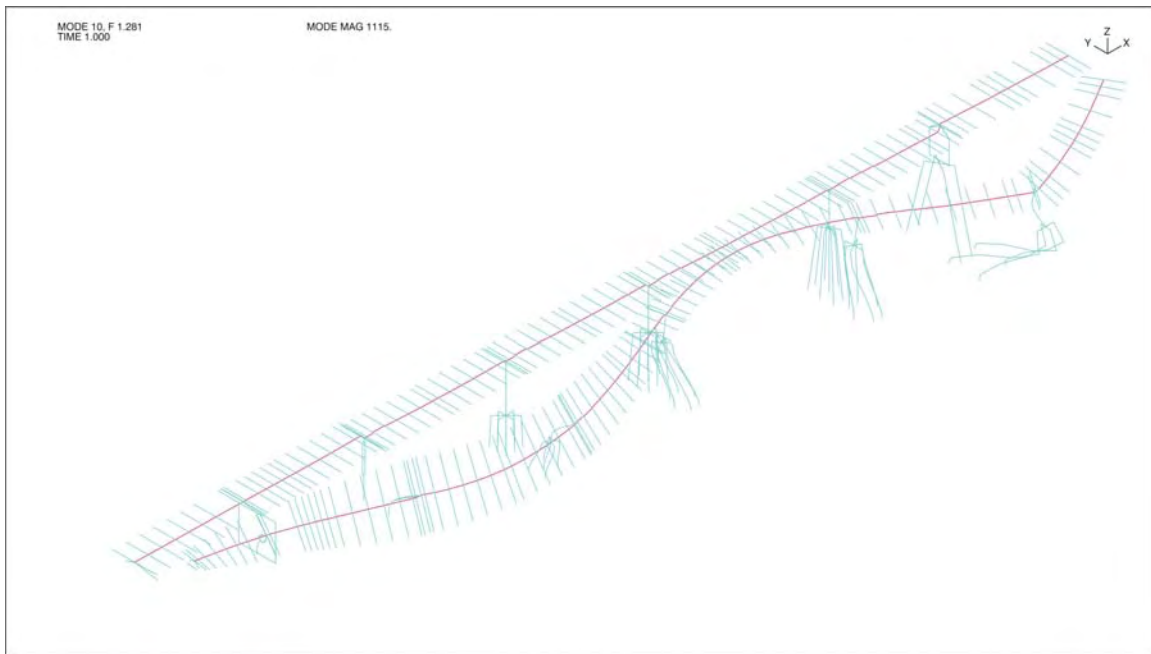


**Figure 3-43: Mode Shape 8 (Torsion-Transverse Line M – Period = 0.93 sec)**

<b>I-90 Homer Hadley Floating Bridge – LRT Impacts</b>		<b>SC Solutions</b>
<b>Subject/Description: Seismic Vulnerability Assessment of the West Approach and Transition Spans</b>	Originator: Joyce Kin-Yan Lee	Date: 8/6/2008
	Checked: Hassan Sedarat	Date: 8/6/2008
Disclaimer: The analysis in this technical document is preliminary and is strictly to be used as advice in determining the feasibility of placing the LRT on the Homer Hadley Floating Bridge and approach spans. It is not intended for any other purpose or as the basis for any final design or construction issue associated with this project	Calculation No.:TM-05	
	Rev No.: 0	Sheet 38 of 62



**Figure 3-44: Mode Shape 9 (Transverse Line L – Period = 0.80 sec)**

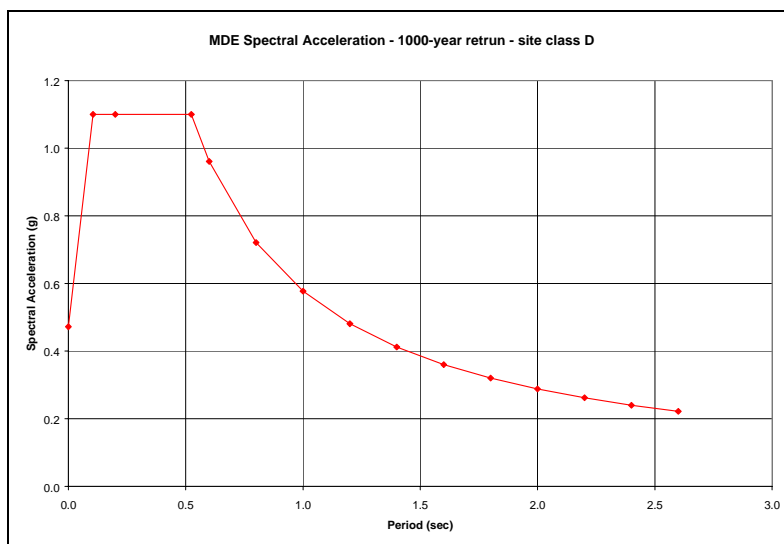


**Figure 3-45: Mode Shape 10 (Transverse Line M – Period = 0.78 sec)**

<b>I-90 Homer Hadley Floating Bridge – LRT Impacts</b>		<b>SC Solutions</b>
<b>Subject/Description: Seismic Vulnerability Assessment of the West Approach and Transition Spans</b>	Originator: Joyce Kin-Yan Lee	Date: 8/6/2008
	Checked: Hassan Sedarat	Date: 8/6/2008
Disclaimer: The analysis in this technical document is preliminary and is strictly to be used as advice in determining the feasibility of placing the LRT on the Homer Hadley Floating Bridge and approach spans. It is not intended for any other purpose or as the basis for any final design or construction issue associated with this project	Calculation No.:TM-05	
	Rev No.: 0	Sheet 39 of 62

### 3.12 Input Spectrum

The input spectrum is the 1000-year return MDE Spectral Acceleration with for site class D as shown in Figure 3-46.



**Figure 3-46: MDE Spectral Acceleration - 1000-year return - site class D**

### 3.13 Response Spectrum Analysis

Using the input spectrum defined in section 3.12, a response spectrum analysis was performed. The two horizontal and one vertical spectra were implemented at the same time. The vertical spectrum is assumed to be 2/3 of the horizontal spectrum shown in Figure 3-46. The modes are combined with the CQC rule. The spatial combination was performed using SRSS rule. Target displacements were obtained from this response spectrum analysis at each node at the superstructure of LL and LM in the two horizontal directions.

### 3.14 Pushover Analysis

The structure was subjected to a pushover analysis. Each node of the superstructure was subjected to the displacements proportions that were obtained from the response spectrum analysis in both horizontal directions. The displacements were then

<b>I-90 Homer Hadley Floating Bridge – LRT Impacts</b>		<b>SC Solutions</b>
<b>Subject/Description: Seismic Vulnerability Assessment of the West Approach and Transition Spans</b>	Originator: Joyce Kin-Yan Lee	Date: 8/6/2008
	Checked: Hassan Sedarat	Date: 8/6/2008
Disclaimer: The analysis in this technical document is preliminary and is strictly to be used as advice in determining the feasibility of placing the LRT on the Homer Hadley Floating Bridge and approach spans. It is not intended for any other purpose or as the basis for any final design or construction issue associated with this project	Calculation No.:TM-05	
	Rev No.: 0	Sheet 40 of 62

incrementally increased to the target displacements and about 30% more. The demands were obtained at the target displacement.

### 3.14.1 Target Displacements at Piers, Abutment and Pontoon

The longitudinal and transverse displacements (in the global coordinates) of the superstructure top of the columns are summarized for each pier in Table 3-12 to Table 3-15. These values were obtained from the response spectrum analysis. The required seat at the pier 7 is about 14 inches. For the seat at the Pontoon the Pontoon displacement needs to be added to 6.78 inch.

**Table 3-12: Line L – Target Displacements at the cg of the Superstructure**

Pier	cg of deck Node	Longitudinal in	Transverse in
Abutment	100011	10.17	0.08
2	102011	10.15	5.08
3	103011	10.12	8.95
4	104011	9.98	11.48
5	105011	9.91	10.04
6	106011	9.93	4.48
7	207011	10.14	1.81
Pontoon	107121	10.15	0.00

**Table 3-13: Line M – Target Displacements at the cg of the Superstructure**

Pier	cg of deck Node	Longitudinal in	Transverse in
Abutment	100012	6.80	0.43
2	102012	6.75	0.79
3	103012	6.57	2.62
4	104012	6.37	4.76
5	105012	6.40	7.87
6	106012	6.46	8.31
7	207012	6.75	5.20
Pontoon	107122	6.78	0.00

**Table 3-14: Line L – Target Displacement at the Top of the Columns**

Pier	Top Node	Longitudinal in	Transverse in
------	----------	-----------------	---------------

<b>I-90 Homer Hadley Floating Bridge – LRT Impacts</b>		<b>SC Solutions</b>
<b>Subject/Description: Seismic Vulnerability Assessment of the West Approach and Transition Spans</b>	Originator: Joyce Kin-Yan Lee	Date: 8/6/2008
	Checked: Hassan Sedarat	Date: 8/6/2008
Disclaimer: The analysis in this technical document is preliminary and is strictly to be used as advice in determining the feasibility of placing the LRT on the Homer Hadley Floating Bridge and approach spans. It is not intended for any other purpose or as the basis for any final design or construction issue associated with this project	Calculation No.:TM-05	
	Rev No.: 0	Sheet 41 of 62

2	2161	0.00	4.92
	2661	0.00	4.91
3	3431	10.15	8.18
4	4231	9.79	10.46
5	5231	9.84	9.18
6	6231	9.81	4.14
7	7191	10.25	2.74
	7691	9.88	2.74

**Table 3-15: Line M – Target Displacement at the Top of the Columns**

	<b>Top</b>	<b>Longitudinal</b>	<b>Transverse</b>
<b>Pier</b>	<b>Node</b>	<b>in</b>	<b>in</b>
2	2160	0.04	1.22
3	3392	6.52	2.23
4	4692	6.11	4.11
5	5692	6.39	7.06
6	6692	6.39	7.68
7	7692	6.51	4.83

### **3.15 Summary of the Results – Pushover Analysis**

Pushover analysis was conducted for the case with extension of 2.5 times pile diameter length below ground level. Results were extracted and were summarized in the following sections.

#### **3.15.1 Distribution of Plastic Curvature**

The distribution of the plastic curvature at the target displacements are shown in Figure 3-47 to Figure 3-59



Subject/Description: **Seismic Vulnerability Assessment of the West Approach and Transition Spans**

Originator: Joyce Kin-Yan Lee

Date: 8/6/2008

Checked: Hassan Sedarat

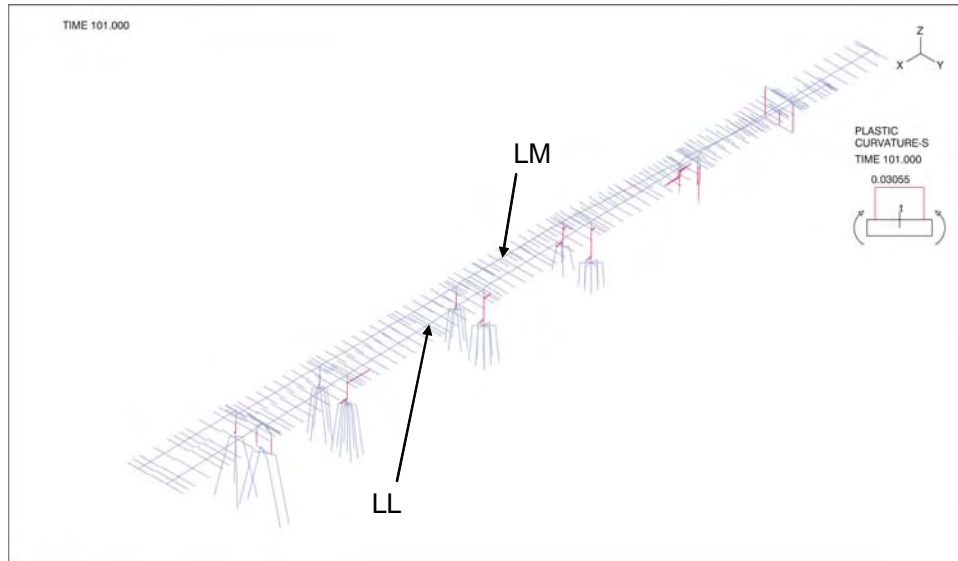
Date: 8/6/2008

Disclaimer: The analysis in this technical document is preliminary and is strictly to be used as advice in determining the feasibility of placing the LRT on the Homer Hadley Floating Bridge and approach spans. It is not intended for any other purpose or as the basis for any final design or construction issue associated with this project

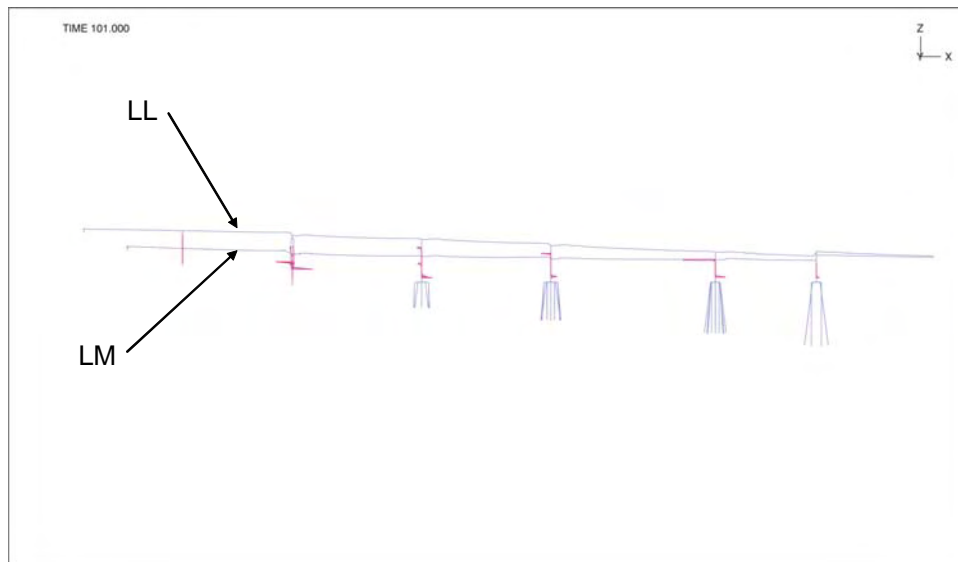
Calculation No.:TM-05

Rev No.: 0

Sheet 42 of 62

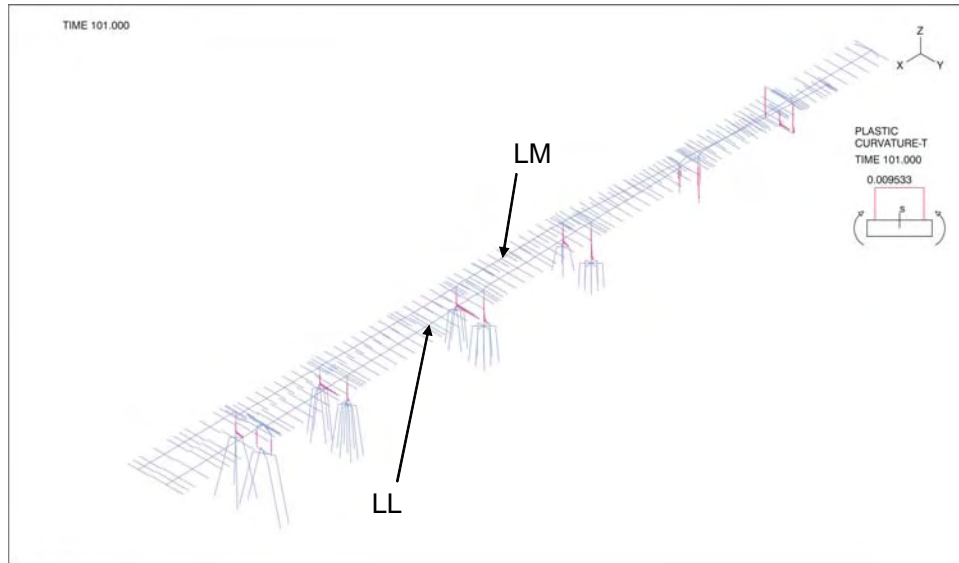


**Figure 3-47: Plastic Curvature about Transverse axis (S-axis) at the Target Displacement**

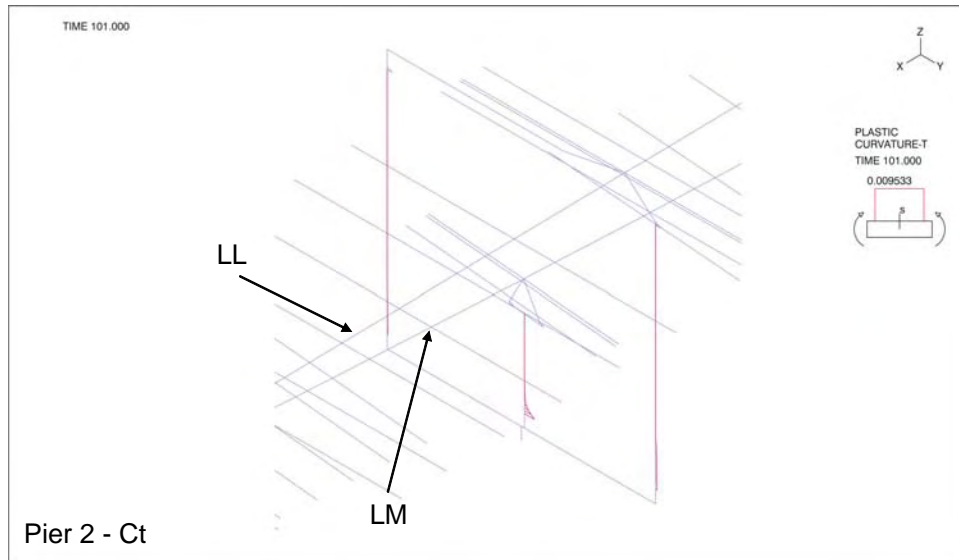


**Figure 3-48: Plastic Curvature about Transverse axis (S-axis) at the Target Displacement**

<b>I-90 Homer Hadley Floating Bridge – LRT Impacts</b>		<b>SC Solutions</b>
<b>Subject/Description: Seismic Vulnerability Assessment of the West Approach and Transition Spans</b>	Originator: Joyce Kin-Yan Lee	Date: 8/6/2008
	Checked: Hassan Sedarat	Date: 8/6/2008
Disclaimer: The analysis in this technical document is preliminary and is strictly to be used as advice in determining the feasibility of placing the LRT on the Homer Hadley Floating Bridge and approach spans. It is not intended for any other purpose or as the basis for any final design or construction issue associated with this project	Calculation No.:TM-05	
	Rev No.: 0	Sheet 43 of 62

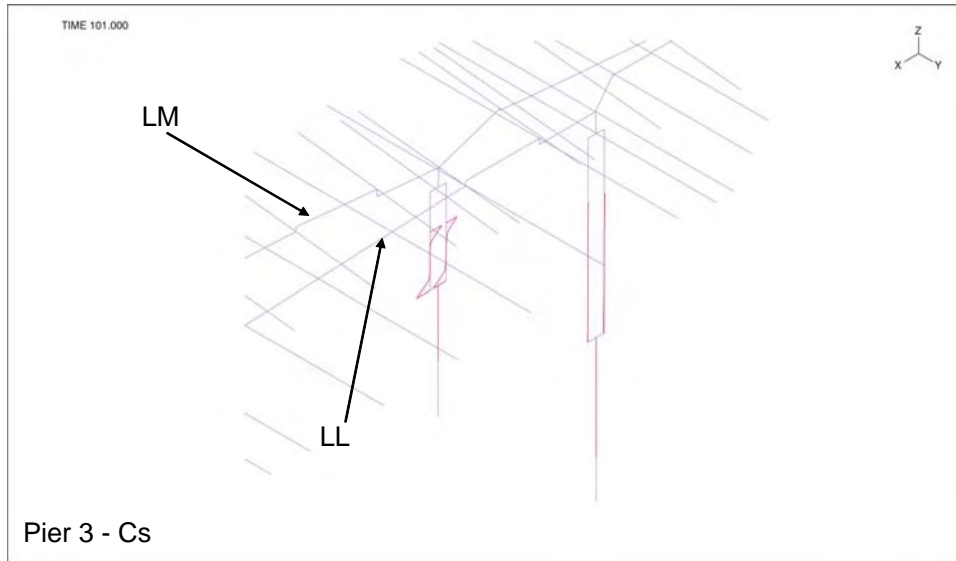


**Figure 3-49: Plastic Curvature about Longitudinal axis (T-axis) at the Target Displacement**

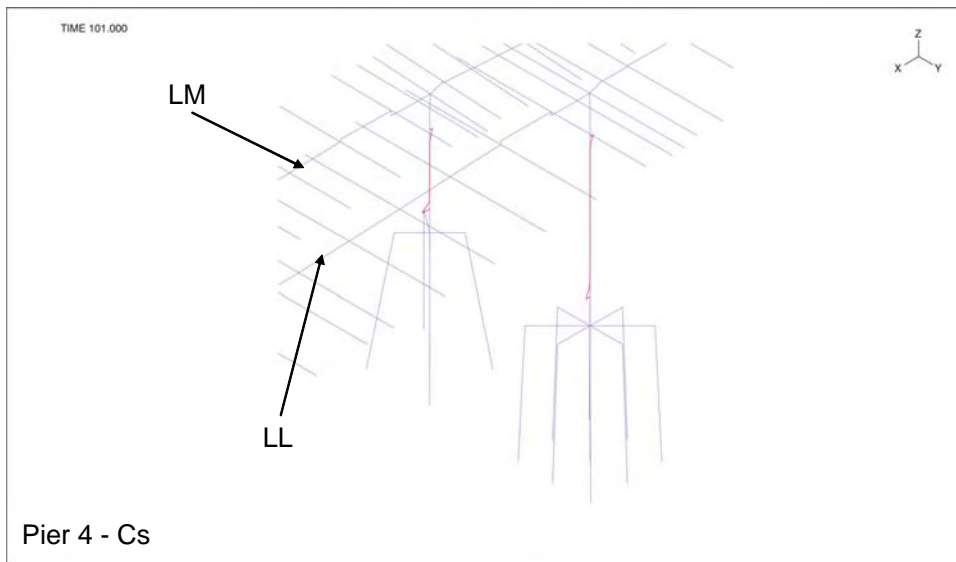


**Figure 3-50: Plastic Curvature about Longitudinal Axis (T-axis) – Pier 2**

<b>I-90 Homer Hadley Floating Bridge – LRT Impacts</b>		<b>SC Solutions</b>
<b>Subject/Description: Seismic Vulnerability Assessment of the West Approach and Transition Spans</b>	Originator: Joyce Kin-Yan Lee	Date: 8/6/2008
	Checked: Hassan Sedarat	Date: 8/6/2008
Disclaimer: The analysis in this technical document is preliminary and is strictly to be used as advice in determining the feasibility of placing the LRT on the Homer Hadley Floating Bridge and approach spans. It is not intended for any other purpose or as the basis for any final design or construction issue associated with this project	Calculation No.:TM-05	
	Rev No.: 0	Sheet 44 of 62

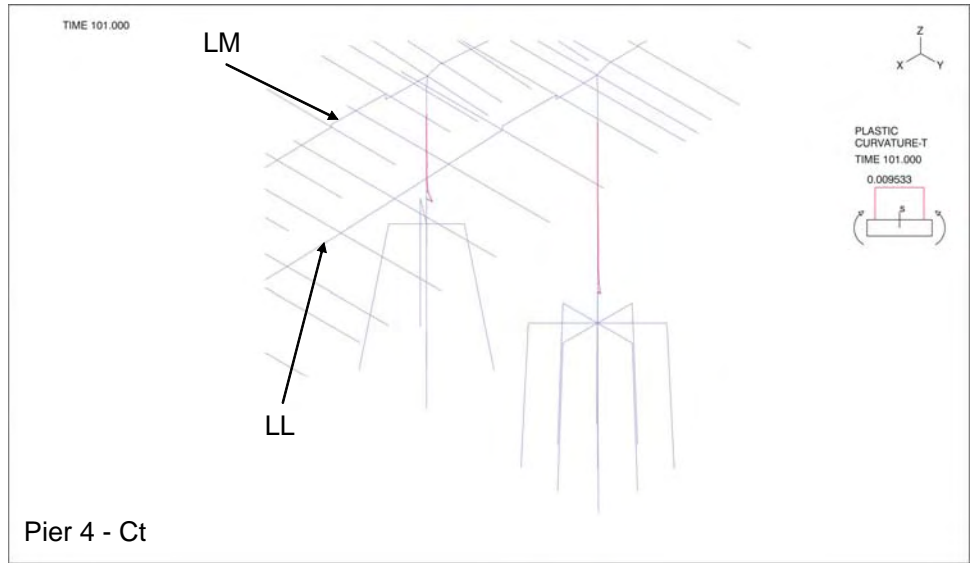


**Figure 3-51: Plastic Curvature about Transverse Axis (S-axis) – Pier 3**

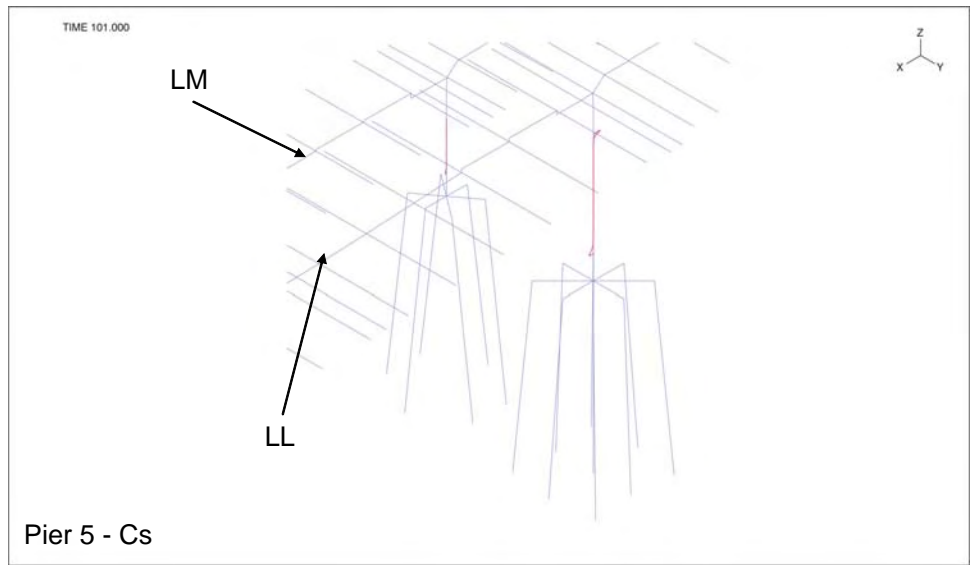


**Figure 3-52: Plastic Curvature about Transverse Axis (S-axis) – Pier 4**

<b>I-90 Homer Hadley Floating Bridge – LRT Impacts</b>		<b>SC Solutions</b>
<b>Subject/Description: Seismic Vulnerability Assessment of the West Approach and Transition Spans</b>	Originator: Joyce Kin-Yan Lee	Date: 8/6/2008
	Checked: Hassan Sedarat	Date: 8/6/2008
Disclaimer: The analysis in this technical document is preliminary and is strictly to be used as advice in determining the feasibility of placing the LRT on the Homer Hadley Floating Bridge and approach spans. It is not intended for any other purpose or as the basis for any final design or construction issue associated with this project	Calculation No.:TM-05	
	Rev No.: 0	Sheet 45 of 62

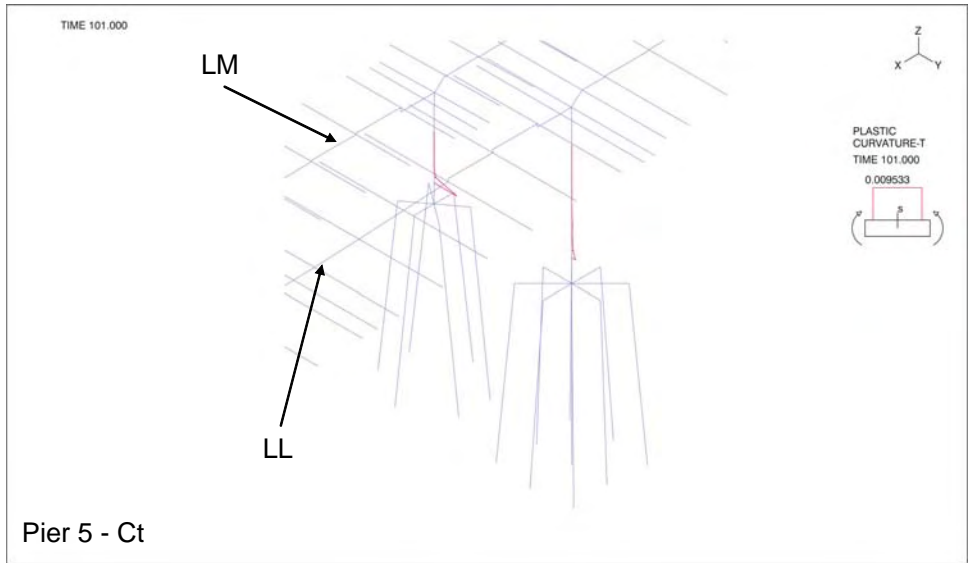


**Figure 3-53: Plastic Curvature about Longitudinal Axis (T-axis) – Pier 4**

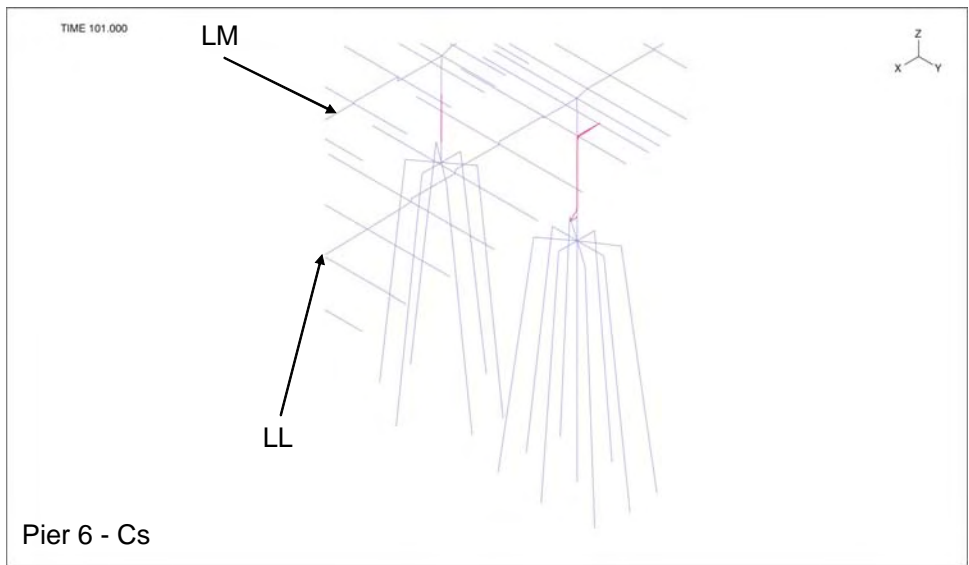


**Figure 3-54: Plastic Curvature about Transverse Axis (S-axis) – Pier 5**

<b>I-90 Homer Hadley Floating Bridge – LRT Impacts</b>		<b>SC Solutions</b>
<b>Subject/Description: Seismic Vulnerability Assessment of the West Approach and Transition Spans</b>	Originator: Joyce Kin-Yan Lee	Date: 8/6/2008
	Checked: Hassan Sedarat	Date: 8/6/2008
Disclaimer: The analysis in this technical document is preliminary and is strictly to be used as advice in determining the feasibility of placing the LRT on the Homer Hadley Floating Bridge and approach spans. It is not intended for any other purpose or as the basis for any final design or construction issue associated with this project	Calculation No.:TM-05	
	Rev No.: 0	Sheet 46 of 62

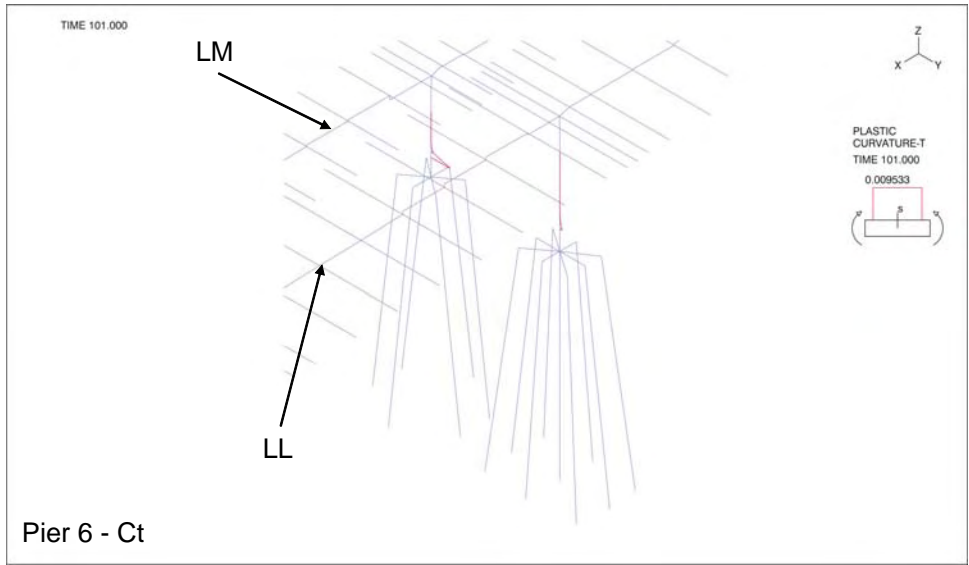


**Figure 3-55: Plastic Curvature about Longitudinal Axis (T-axis) – Pier 5**

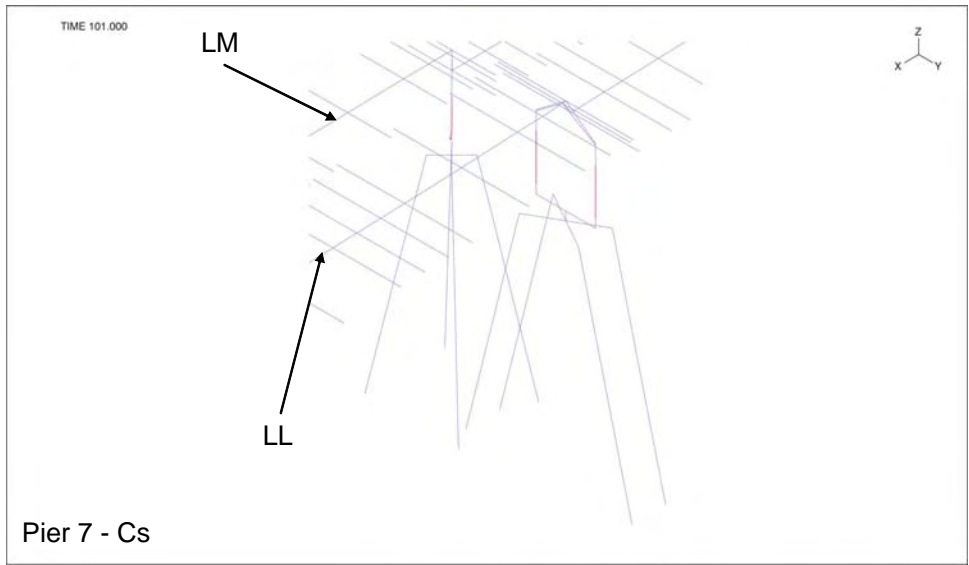


**Figure 3-56: Plastic Curvature about Transverse Axis (S-axis) – Pier 6**

<b>I-90 Homer Hadley Floating Bridge – LRT Impacts</b>		<b>SC Solutions</b>
<b>Subject/Description: Seismic Vulnerability Assessment of the West Approach and Transition Spans</b>	Originator: Joyce Kin-Yan Lee	Date: 8/6/2008
	Checked: Hassan Sedarat	Date: 8/6/2008
Disclaimer: The analysis in this technical document is preliminary and is strictly to be used as advice in determining the feasibility of placing the LRT on the Homer Hadley Floating Bridge and approach spans. It is not intended for any other purpose or as the basis for any final design or construction issue associated with this project	Calculation No.:TM-05	
	Rev No.: 0	Sheet 47 of 62

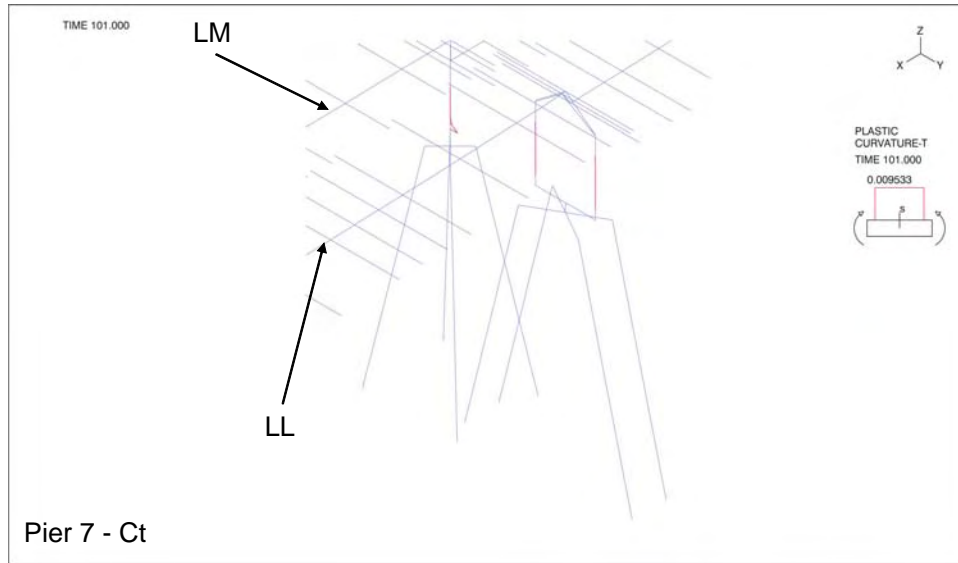


**Figure 3-57: Plastic Curvature about Longitudinal Axis (T-axis) – Pier 6**



**Figure 3-58: Plastic Curvature about Transverse Axis (S-axis) – Pier 7**

<b>I-90 Homer Hadley Floating Bridge – LRT Impacts</b>		<b>SC Solutions</b>
<b>Subject/Description: Seismic Vulnerability Assessment of the West Approach and Transition Spans</b>	Originator: Joyce Kin-Yan Lee	Date: 8/6/2008
	Checked: Hassan Sedarat	Date: 8/6/2008
Disclaimer: The analysis in this technical document is preliminary and is strictly to be used as advice in determining the feasibility of placing the LRT on the Homer Hadley Floating Bridge and approach spans. It is not intended for any other purpose or as the basis for any final design or construction issue associated with this project	Calculation No.:TM-05	
	Rev No.: 0	Sheet 48 of 62



**Figure 3-59: Plastic Curvature about Longitudinal Axis (T-axis) – Pier 7**

### 3.15.2 Column Drift

Column drifts were computed and were compared against the values from FEMA 302 in Table 3-16 and Table 3-17.

From the results, shown in these tables, column drifts were within the limit required by FEMA 302. However, the allowable values from FEMA 302 were used for simple building structures. With all kinds of irregularities on a curvy bridge, the allowable limits set by FEMA were deemed as insufficient for comparison. From this table it becomes clear that piers 3 to 6 for Line L and Piers 3 and 4 for Line M show stronger coupling for the transverse and longitudinal deformations.

**Table 3-16: Line L Column Drift Comparison at the Target Displacement**

Pier	Top Node	Bottom Node	East - West	North - South	Column Height (ft)	FEMA 302 Table 5.2.8 0.02 h (in)	East - West	North - South
			Drift - x (in)	Drift - y (in)			Pushover / FEMA Ratio	
2	2161	2031	0.0000	4.9152	45.35	10.88	0.00	0.45
	2661	2531	0.0000	4.9084	45.35	10.88	0.00	0.45
3	3431	3031	10.1526	8.1800	64.90	15.58	0.65	0.53

<b>I-90 Homer Hadley Floating Bridge – LRT Impacts</b>		<b>SC Solutions</b>
<b>Subject/Description: Seismic Vulnerability Assessment of the West Approach and Transition Spans</b>	Originator: Joyce Kin-Yan Lee	Date: 8/6/2008
	Checked: Hassan Sedarat	Date: 8/6/2008
Disclaimer: The analysis in this technical document is preliminary and is strictly to be used as advice in determining the feasibility of placing the LRT on the Homer Hadley Floating Bridge and approach spans. It is not intended for any other purpose or as the basis for any final design or construction issue associated with this project	Calculation No.:TM-05	
	Rev No.: 0	Sheet 49 of 62

4	4231	4031	8.3526	9.7905	55.26	13.26	0.63	0.74
5	5231	5031	5.2149	6.8592	45.62	10.95	0.48	0.63
6	6231	6031	4.7666	2.0846	35.64	8.55	0.56	0.24
7	7191	7031	0.1408	2.3976	30.25	7.26	0.02	0.33
	7691	7531	0.1441	2.3977	30.25	7.26	0.02	0.33

**Table 3-17: Line M Column Drift Comparison at the Target Displacement**

Pier	Top Node	Bottom Node	East - West	North - South	Column Height (in)	FEMA 302 Table 5.2.8 0.02 h (in)	East - West	North - South
			Drift - x (in)	Drift - y (in)			Pushover / FEMA Ratio	
2	2160	2032	0.0443	1.2204	17.14	4.11	0.01	0.30
3	3392	3532	6.5219	2.2349	35.01	8.40	0.78	0.27
4	4692	4532	4.4351	3.5939	29.58	7.10	0.62	0.51
5	5692	5532	0.6673	4.3194	25.76	6.18	0.11	0.70
6	6692	6532	0.4212	3.0776	24.74	5.94	0.07	0.52
7	7692	7532	0.3600	2.2576	24.73	5.94	0.06	0.38

### 3.15.3 Column Strains

Column strains at primarily the locations of bottom and top of columns at each pier are computed and are compared with limits of 0.06 for steel and 2/3 of ultimate concrete strain obtained from Mander’s equations for each section. These are summarized in Table 3-18 to Table 3-21.

From the values of the D/C in these tables it can be observed that columns at piers 3 through 6 have experienced various levels of plasticity. Among them, Pier 6 on line L has reached the highest strain value which exceeds the limit significantly.

The concrete strains are compared with a uniform strain limit of 0.005 ft/ft in Table 3-22 to Table 3-25.



<b>I-90 Homer Hadley Floating Bridge – LRT Impacts</b>		<b>SC Solutions</b>
<b>Subject/Description: Seismic Vulnerability Assessment of the West Approach and Transition Spans</b>	Originator: Joyce Kin-Yan Lee	Date: 8/6/2008
	Checked: Hassan Sedarat	Date: 8/6/2008
Disclaimer: The analysis in this technical document is preliminary and is strictly to be used as advice in determining the feasibility of placing the LRT on the Homer Hadley Floating Bridge and approach spans. It is not intended for any other purpose or as the basis for any final design or construction issue associated with this project	Calculation No.:TM-05	
	Rev No.: 0	Sheet 50 of 62

**Table 3-18: Steel and Concrete Strain Values at the Target Displacements -- Line L – Pier Bottom Elements**

Pier	Steel Strain	Allowable	D/C Ratio	Concrete Strain	Allowable	D/C Ratio
	(ft/ft)	(ft/ft)		(ft/ft)	2/3 $\epsilon_{cu}$ (ft/ft)	
2	0.0058	0.0600	0.10	0.0017	0.0115	0.1456
	0.0058	0.0600	0.0971	0.0009	0.0115	0.0769
3 solid	0.0057	0.0600	0.0948	0.0017	0.0059	0.2911
3 split	0.0023	0.0600	0.0382	0.0035	0.0143	0.2429
3 split	0.0033	0.0600	0.0545	0.0033	0.0143	0.2309
4	0.0528	0.0600	0.8797	0.0105	0.0072	<b>1.4542</b>
5	0.0568	0.0600	0.9467	0.0124	0.0072	<b>1.7181</b>
6	0.0787	0.0600	<b>1.3115</b>	0.0151	0.0072	<b>2.0903</b>
7	0.0022	0.0600	0.0369	0.0007	0.0077	0.0895

**Table 3-19: Steel and Concrete Strain Values at the Target Displacements -- Line L – Pier Top Elements**

Pier	Steel Strain	Allowable	D/C Ratio	Concrete Strain	Allowable	D/C Ratio
	(ft/ft)	(ft/ft)		(ft/ft)	2/3 $\epsilon_{cu}$ (ft/ft)	
2	0.0001	0.0600	0.0011	0.0000	0.0067	0.0043
	0.0001	0.0600	0.0015	0.0000	0.0067	0.0031
3 split	0.0383	0.0600	0.6388	0.0077	0.0075	<b>1.0363</b>
3 split	0.0427	0.0600	0.7108	0.0069	0.0075	0.9296
4	0.0352	0.0600	0.5872	0.0070	0.0045	<b>1.5678</b>
5	0.0666	0.0600	<b>1.1092</b>	0.0144	0.0047	<b>3.0507</b>
6	0.2076	0.0600	<b>3.4600</b>	0.0434	0.0045	<b>9.7097</b>
7	0.0023	0.0600	0.0384	0.0008	0.0041	0.1990
	0.0025	0.0600	0.0410	0.0007	0.0041	0.1699

<b>I-90 Homer Hadley Floating Bridge – LRT Impacts</b>		<b>SC Solutions</b>
<b>Subject/Description: Seismic Vulnerability Assessment of the West Approach and Transition Spans</b>	Originator: Joyce Kin-Yan Lee	Date: 8/6/2008
	Checked: Hassan Sedarat	Date: 8/6/2008
Disclaimer: The analysis in this technical document is preliminary and is strictly to be used as advice in determining the feasibility of placing the LRT on the Homer Hadley Floating Bridge and approach spans. It is not intended for any other purpose or as the basis for any final design or construction issue associated with this project	Calculation No.:TM-05	
	Rev No.: 0	Sheet 51 of 62

**Table 3-20: Steel and Concrete Strain Values at the Target Displacements -- Line M – Pier Bottom Elements**

Pier	Steel Strain	Allowable	D/C Ratio	Concrete Strain	Allowable	D/C Ratio
	(ft/ft)	(ft/ft)		(ft/ft)	2/3 $\epsilon_{cu}$ (ft/ft)	
2	0.0393	0.0600	0.6553	0.0037	0.0043	0.8552
3 solid	0.0036	0.0600	0.0595	0.0016	0.0070	0.2230
3 split	0.0088	0.0600	0.1462	0.0104	0.0155	0.6744
3 split	0.0121	0.0600	0.2020	0.0086	0.0155	0.5592
4	0.1023	0.0600	<b>1.7050</b>	0.0184	0.0077	<b>2.4000</b>
5	0.0857	0.0600	<b>1.4287</b>	0.0134	0.0077	<b>1.7504</b>
6	0.0638	0.0600	1.0632	0.0091	0.0077	<b>1.1813</b>
7	0.0624	0.0600	1.0393	0.0090	0.0077	1.1798

**Table 3-21: Steel and Concrete Strain Values at the Target Displacements -- Line M – Pier Top Elements**

Pier	Steel Strain	Allowable	D/C Ratio	Concrete Strain	Allowable	D/C Ratio
	(ft/ft)	(ft/ft)		(ft/ft)	2/3 $\epsilon_{cu}$ (ft/ft)	
2	0.0008	0.0600	0.0127	0.0002	0.0072	0.0327
3 split	0.0078	0.0600	0.1304	0.0092	0.0155	0.5937
3 split	0.0100	0.0600	0.1670	0.0071	0.0155	0.4569
4	0.0328	0.0600	0.5465	0.0067	0.0048	<b>1.3892</b>
5	0.0060	0.0600	0.0993	0.0020	0.0037	0.5451
6	0.0025	0.0600	0.0417	0.0011	0.0037	0.2901
7	0.0034	0.0600	0.0562	0.0012	0.0037	0.3319

<b>I-90 Homer Hadley Floating Bridge – LRT Impacts</b>		<b>SC Solutions</b>
<b>Subject/Description: Seismic Vulnerability Assessment of the West Approach and Transition Spans</b>	Originator: Joyce Kin-Yan Lee	Date: 8/6/2008
	Checked: Hassan Sedarat	Date: 8/6/2008
Disclaimer: The analysis in this technical document is preliminary and is strictly to be used as advice in determining the feasibility of placing the LRT on the Homer Hadley Floating Bridge and approach spans. It is not intended for any other purpose or as the basis for any final design or construction issue associated with this project	Calculation No.:TM-05	
	Rev No.: 0	Sheet 52 of 62

**Table 3-22: Concrete Strain Values at the Target Displacements -- Line L Pier Bottom Elements – Concrete Limit Strain = 0.005**

Pier	Concrete Strain	Allowable	D/C Ratio
	(ft/ft)	0.005 (ft/ft)	
2	0.0017	0.0050	0.3338
	0.0009	0.0050	0.1763
3 solid	0.0017	0.0050	0.3416
3 split	0.0035	0.0050	0.6964
3 split	0.0033	0.0050	0.6618
4	0.0105	0.0050	<b>2.0940</b>
5	0.0124	0.0050	<b>2.4740</b>
6	0.0151	0.0050	<b>3.0100</b>
7	0.0007	0.0050	0.1372

**Table 3-23: Concrete Strain Values at the Target Displacements -- Line L Pier Top Elements – Concrete Limit Strain = 0.005**

Pier	Concrete Strain	Allowable	D/C Ratio
	(ft/ft)	0.005 (ft/ft)	
2	0.0000	0.0050	0.0058
	0.0000	0.0050	0.0041
3 split	0.0077	0.0050	<b>1.5476</b>
3 split	0.0069	0.0050	<b>1.3882</b>
4	0.0070	0.0050	<b>1.4006</b>
5	0.0144	0.0050	<b>2.8880</b>
6	0.0434	0.0050	<b>8.6740</b>
7	0.0008	0.0050	0.1645
	0.0007	0.0050	0.1404

<b>I-90 Homer Hadley Floating Bridge – LRT Impacts</b>		<b>SC Solutions</b>
<b>Subject/Description: Seismic Vulnerability Assessment of the West Approach and Transition Spans</b>	Originator: Joyce Kin-Yan Lee	Date: 8/6/2008
	Checked: Hassan Sedarat	Date: 8/6/2008
Disclaimer: The analysis in this technical document is preliminary and is strictly to be used as advice in determining the feasibility of placing the LRT on the Homer Hadley Floating Bridge and approach spans. It is not intended for any other purpose or as the basis for any final design or construction issue associated with this project	Calculation No.:TM-05	
	Rev No.: 0	Sheet 53 of 62

**Table 3-24: Concrete Strain Values at the Target Displacements -- Line M Pier Bottom Elements – Concrete Limit Strain = 0.005**

Pier	Concrete Strain	Allowable	D/C Ratio
	(ft/ft)	0.005 (ft/ft)	
2	0.0037	0.0050	0.7412
3 solid	0.0016	0.0050	0.3122
3 split	0.0104	0.0050	<b>2.0860</b>
3 split	0.0086	0.0050	<b>1.7298</b>
4	0.0184	0.0050	<b>3.6800</b>
5	0.0134	0.0050	<b>2.6840</b>
6	0.0091	0.0050	<b>1.8114</b>
7	0.0090	0.0050	1.8090

**Table 3-25: Concrete Strain Values at the Target Displacements -- Line M Pier Top Elements – Concrete Limit Strain = 0.005**

Pier	Concrete Strain	Allowable	D/C Ratio
	(ft/ft)	0.005 (ft/ft)	
2	0.0002	0.0050	0.0471
3 split	0.0092	0.0050	<b>1.8366</b>
3 split	0.0071	0.0050	<b>1.4134</b>
4	0.0067	0.0050	<b>1.3336</b>
5	0.0020	0.0050	0.4070
6	0.0011	0.0050	0.2166
7	0.0012	0.0050	0.2478

### 3.15.4 Force-Displacement Relationship

Base shear and displacement at columns of all piers were extracted and were plotted against each other as shown in Figure 3-60 through Figure 3-73. Target displacement to be pushed at each pier is marked on each plot. It is shown that most of the pier has gone into plastic region.

Subject/Description: **Seismic Vulnerability Assessment of the West Approach and Transition Spans**

Originator: Joyce Kin-Yan Lee

Date: 8/6/2008

Checked: Hassan Sedarat

Date: 8/6/2008

Disclaimer: The analysis in this technical document is preliminary and is strictly to be used as advice in determining the feasibility of placing the LRT on the Homer Hadley Floating Bridge and approach spans. It is not intended for any other purpose or as the basis for any final design or construction issue associated with this project

Calculation No.:TM-05

Rev No.: 0

Sheet 54 of 62

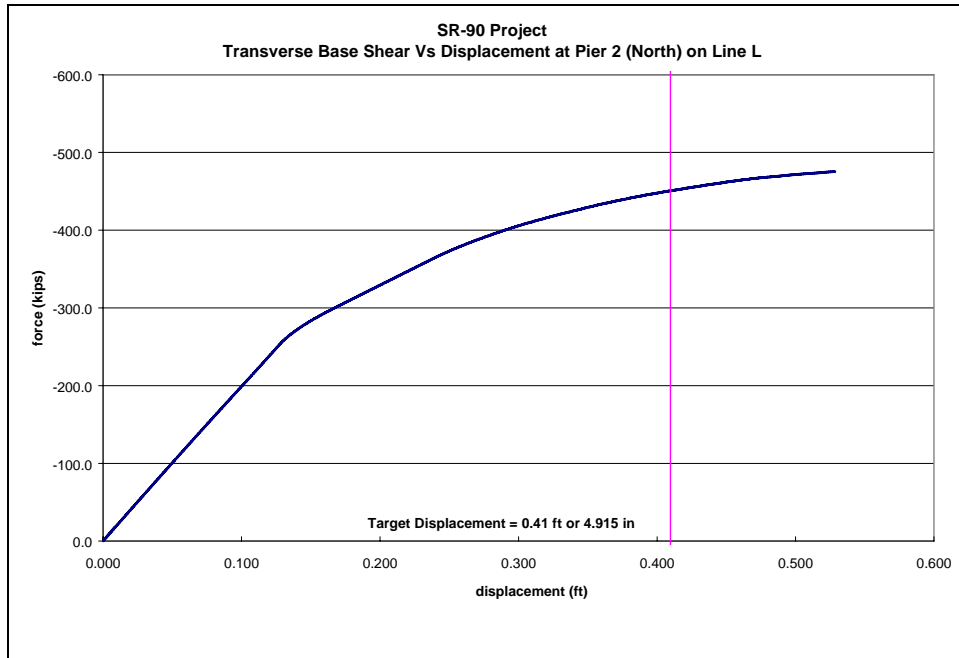


Figure 3-60: Column Force vs. Displacement at Pier 2 (North Column) on Line L

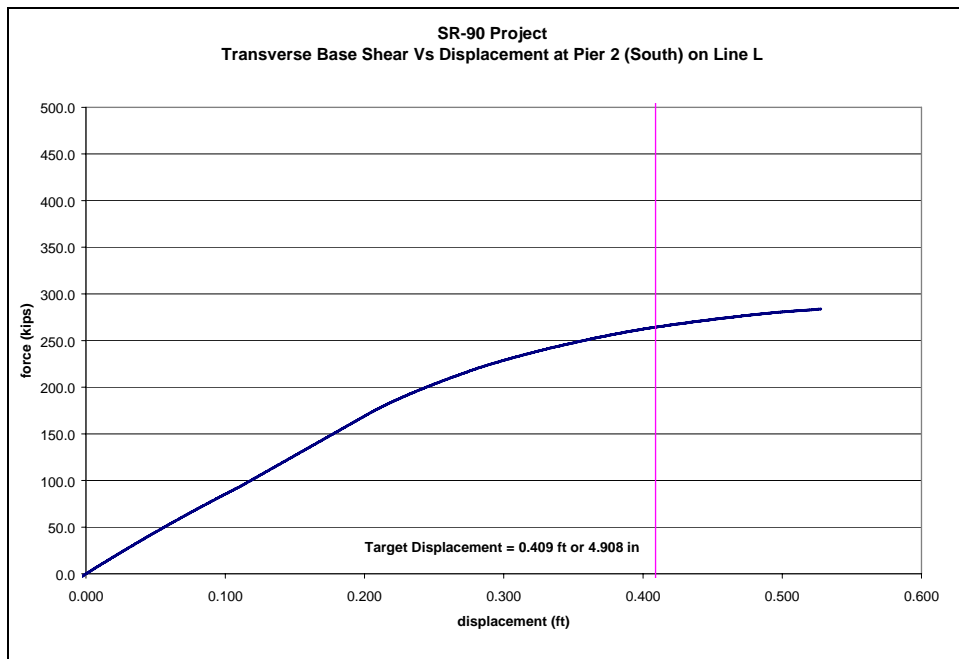


Figure 3-61: Column Force vs. Displacement at Pier 2 (South Column) on Line L

Subject/Description: **Seismic Vulnerability Assessment of the West Approach and Transition Spans**

Originator: Joyce Kin-Yan Lee

Date: 8/6/2008

Checked: Hassan Sedarat

Date: 8/6/2008

Disclaimer: The analysis in this technical document is preliminary and is strictly to be used as advice in determining the feasibility of placing the LRT on the Homer Hadley Floating Bridge and approach spans. It is not intended for any other purpose or as the basis for any final design or construction issue associated with this project

Calculation No.:TM-05

Rev No.: 0

Sheet 55 of 62

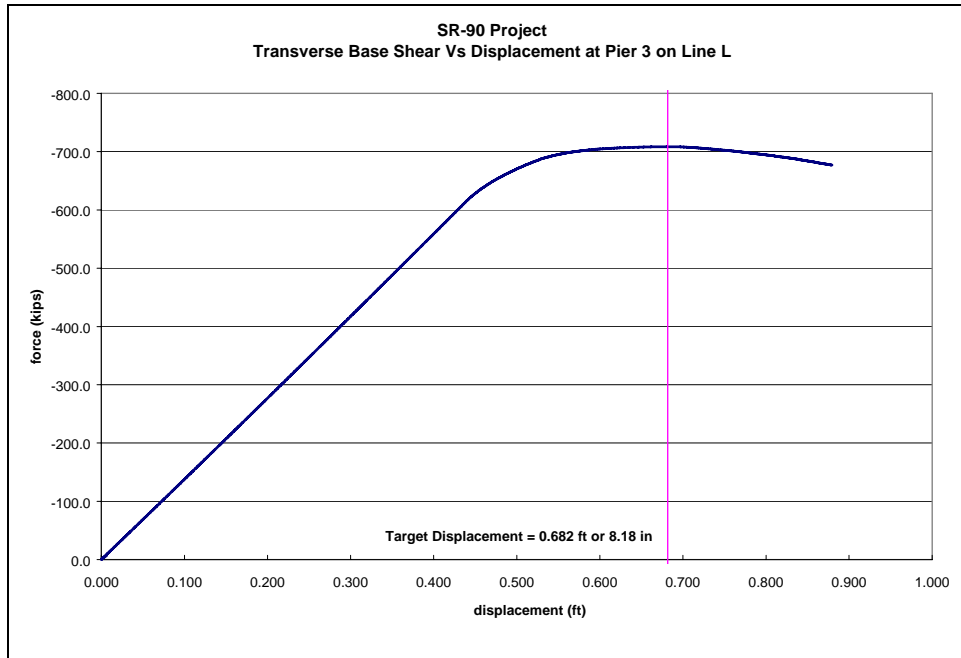


Figure 3-62: Column Force vs. Displacement at Pier 3 on Line L

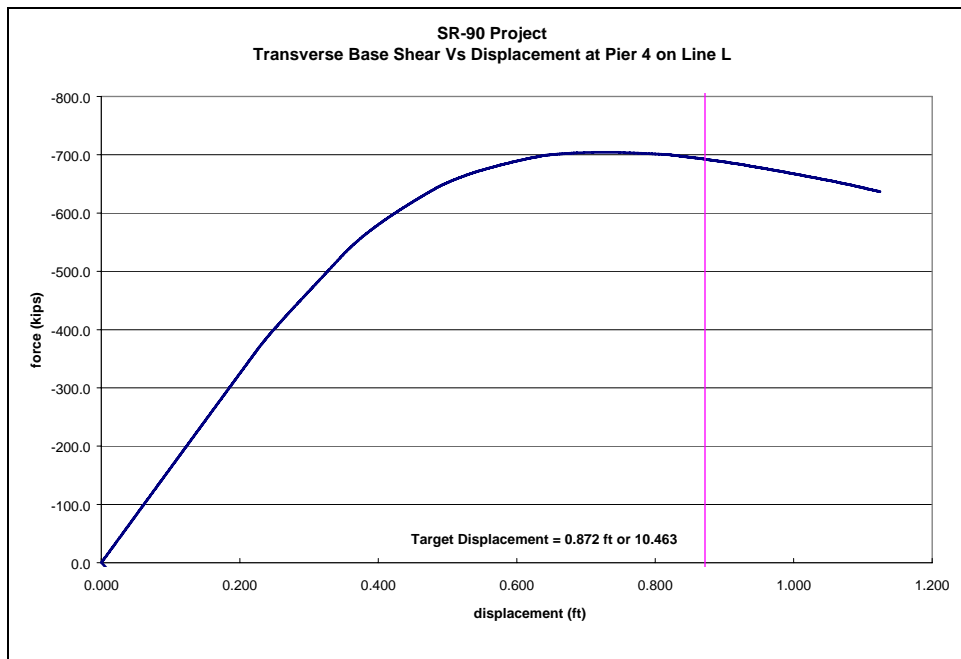


Figure 3-63: Column Force vs. Displacement at Pier 4 on Line L

Subject/Description: **Seismic Vulnerability Assessment of the West Approach and Transition Spans**

Originator: Joyce Kin-Yan Lee

Date: 8/6/2008

Checked: Hassan Sedarat

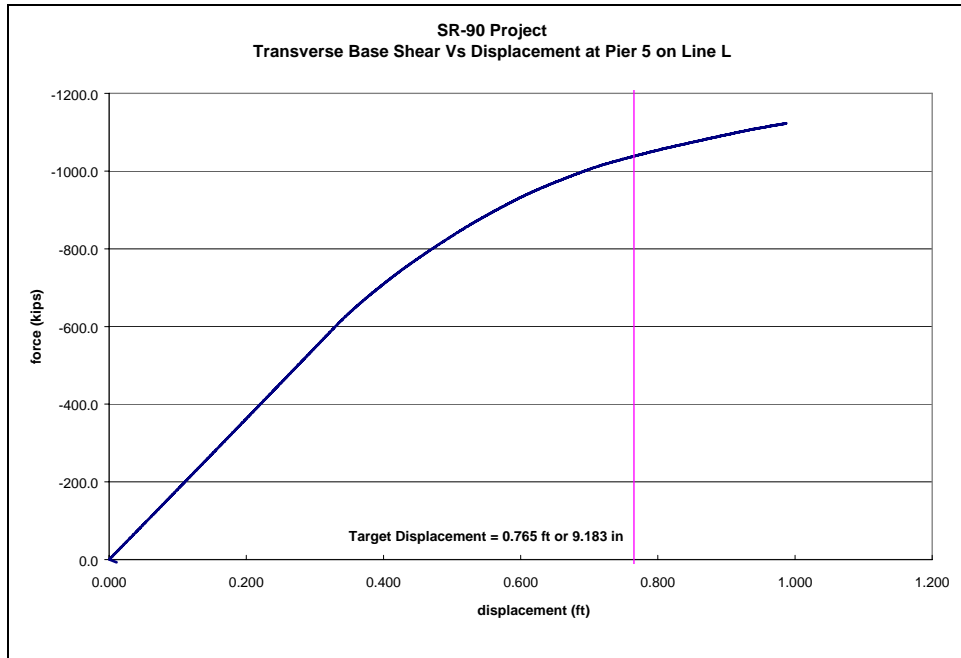
Date: 8/6/2008

Disclaimer: The analysis in this technical document is preliminary and is strictly to be used as advice in determining the feasibility of placing the LRT on the Homer Hadley Floating Bridge and approach spans. It is not intended for any other purpose or as the basis for any final design or construction issue associated with this project

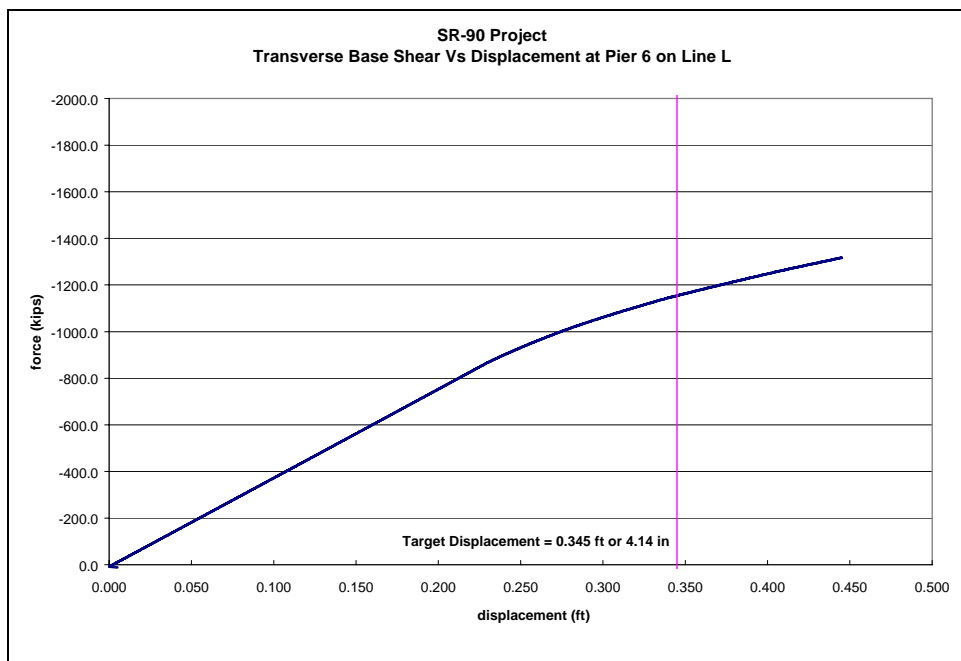
Calculation No.:TM-05

Rev No.: 0

Sheet 56 of 62

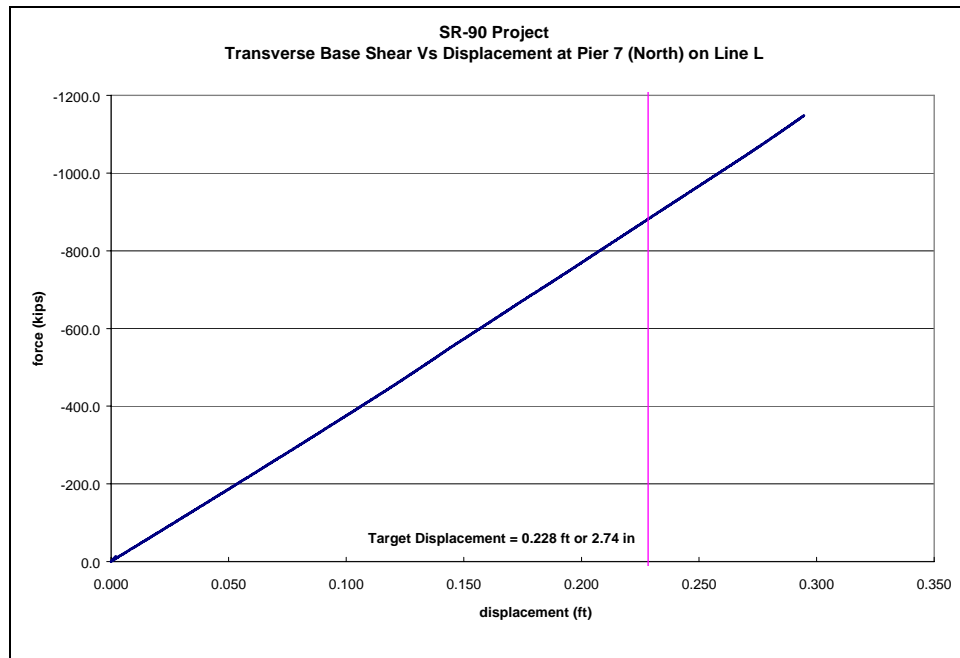


**Figure 3-64: Column Force vs. Displacement at Pier 5 on Line L**

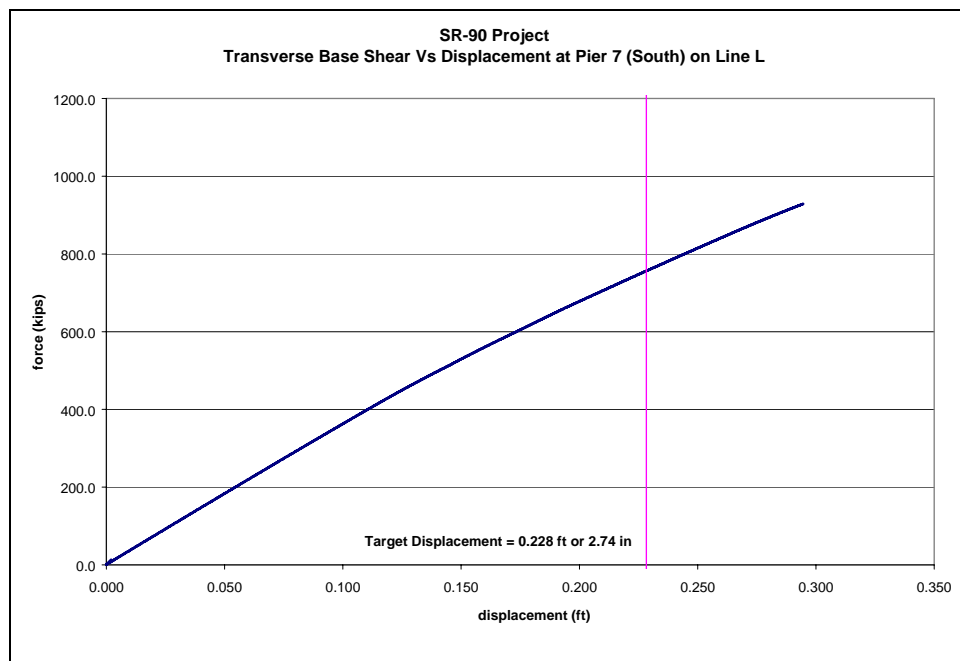


**Figure 3-65: Column Force vs. Displacement at Pier 6 on Line L**

<b>I-90 Homer Hadley Floating Bridge – LRT Impacts</b>		<b>SC Solutions</b>
<b>Subject/Description: Seismic Vulnerability Assessment of the West Approach and Transition Spans</b>	Originator: Joyce Kin-Yan Lee	Date: 8/6/2008
	Checked: Hassan Sedarat	Date: 8/6/2008
Disclaimer: The analysis in this technical document is preliminary and is strictly to be used as advice in determining the feasibility of placing the LRT on the Homer Hadley Floating Bridge and approach spans. It is not intended for any other purpose or as the basis for any final design or construction issue associated with this project	Calculation No.:TM-05	
	Rev No.: 0	Sheet 57 of 62



**Figure 3-66: Column Force vs. Displacement at Pier 7 (North Column) on Line L**



**Figure 3-67: Column Force vs. Displacement at Pier 7 (South Column) on Line L**



Subject/Description: **Seismic Vulnerability Assessment of the West Approach and Transition Spans**

Originator: Joyce Kin-Yan Lee

Date: 8/6/2008

Checked: Hassan Sedarat

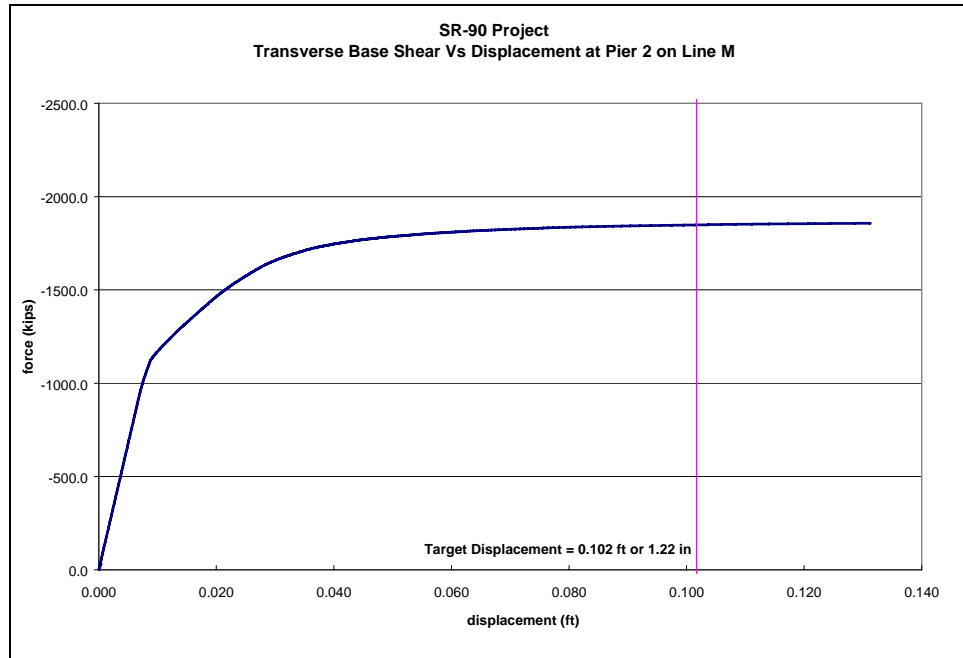
Date: 8/6/2008

Disclaimer: The analysis in this technical document is preliminary and is strictly to be used as advice in determining the feasibility of placing the LRT on the Homer Hadley Floating Bridge and approach spans. It is not intended for any other purpose or as the basis for any final design or construction issue associated with this project

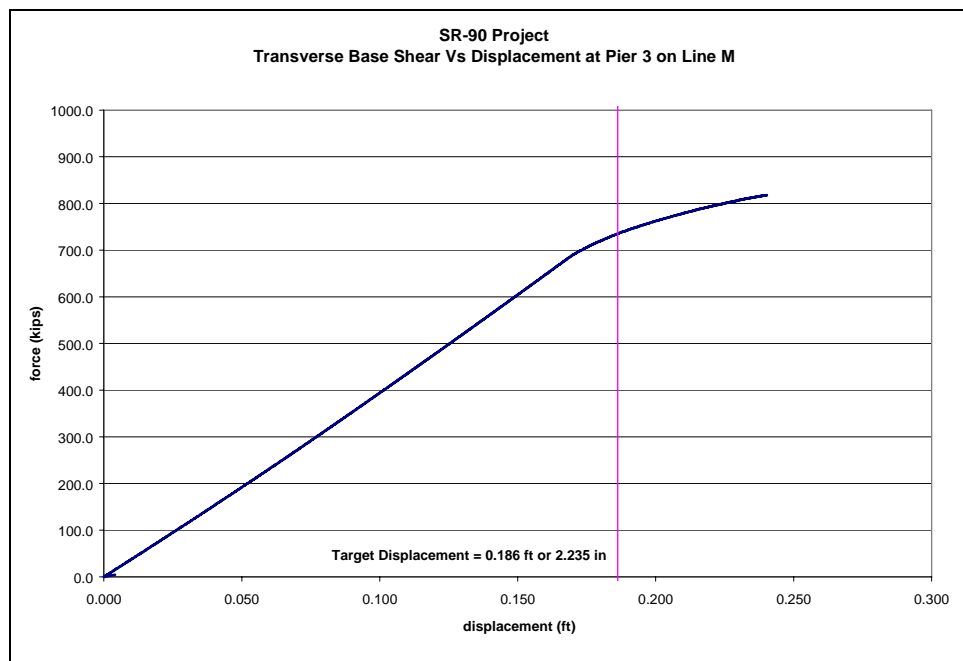
Calculation No.:TM-05

Rev No.: 0

Sheet 58 of 62



**Figure 3-68: Column Force vs. Displacement at Pier 2 on Line M**



**Figure 3-69: Column Force vs. Displacement at Pier 3 on Line M**

Subject/Description: **Seismic Vulnerability Assessment of the West Approach and Transition Spans**

Originator: Joyce Kin-Yan Lee

Date: 8/6/2008

Checked: Hassan Sedarat

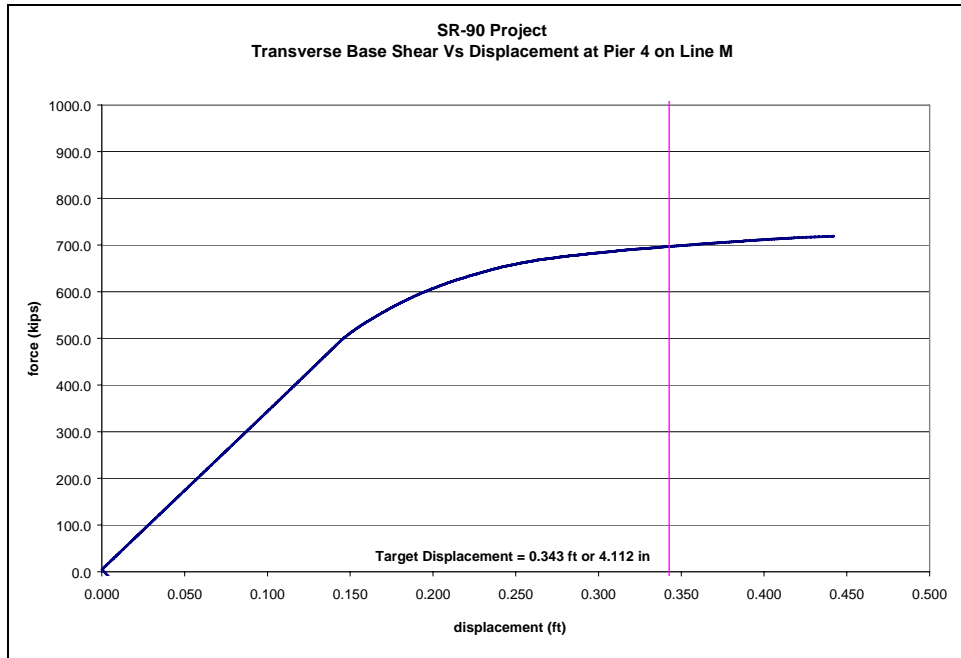
Date: 8/6/2008

Disclaimer: The analysis in this technical document is preliminary and is strictly to be used as advice in determining the feasibility of placing the LRT on the Homer Hadley Floating Bridge and approach spans. It is not intended for any other purpose or as the basis for any final design or construction issue associated with this project

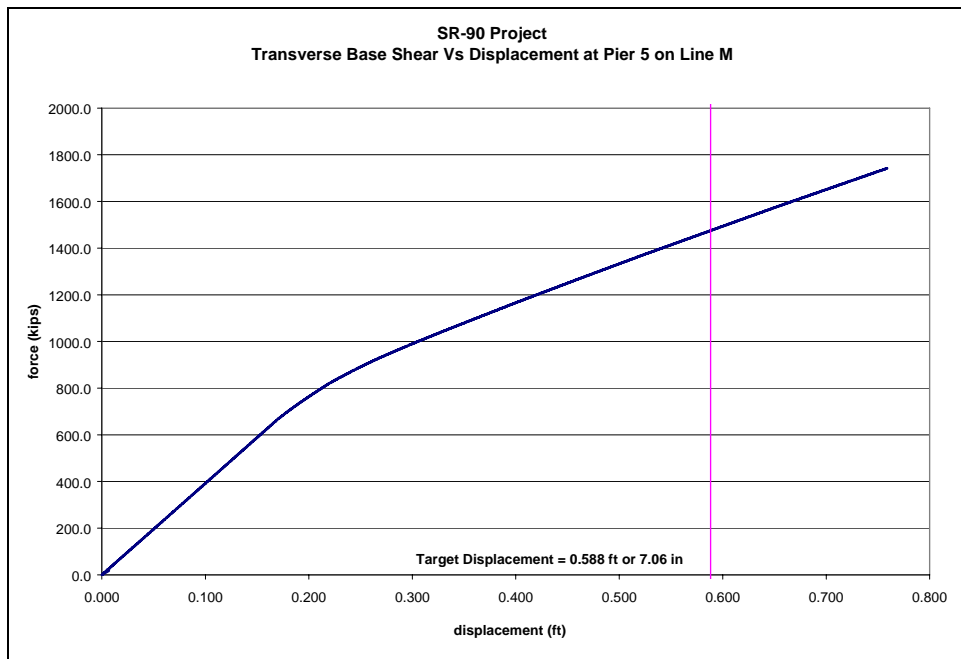
Calculation No.:TM-05

Rev No.: 0

Sheet 59 of 62



**Figure 3-70: Column Force vs. Displacement at Pier 4 on Line M**



**Figure 3-71: Column Force vs. Displacement at Pier 5 on Line M**

Subject/Description: **Seismic Vulnerability Assessment of the West Approach and Transition Spans**

Originator: Joyce Kin-Yan Lee

Date: 8/6/2008

Checked: Hassan Sedarat

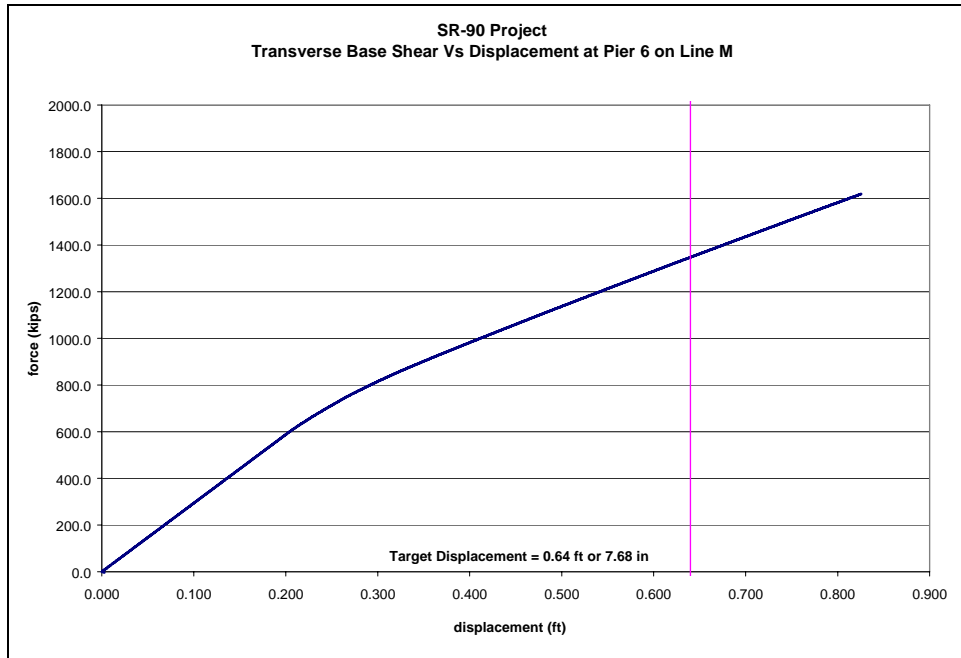
Date: 8/6/2008

Disclaimer: The analysis in this technical document is preliminary and is strictly to be used as advice in determining the feasibility of placing the LRT on the Homer Hadley Floating Bridge and approach spans. It is not intended for any other purpose or as the basis for any final design or construction issue associated with this project

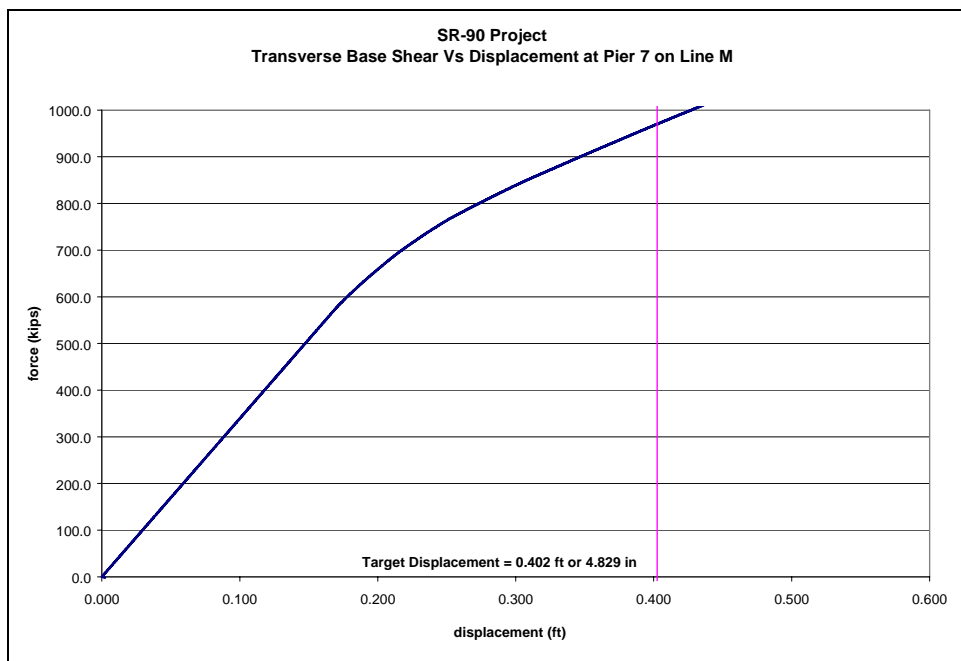
Calculation No.:TM-05

Rev No.: 0

Sheet 60 of 62



**Figure 3-72: Column Force vs. Displacement at Pier 6 on Line M**



**Figure 3-73: Column Force vs. Displacement at Pier 7 on Line M**

<b>I-90 Homer Hadley Floating Bridge – LRT Impacts</b>		<b>SC Solutions</b>
<b>Subject/Description: Seismic Vulnerability Assessment of the West Approach and Transition Spans</b>	Originator: Joyce Kin-Yan Lee	Date: 8/6/2008
	Checked: Hassan Sedarat	Date: 8/6/2008
Disclaimer: The analysis in this technical document is preliminary and is strictly to be used as advice in determining the feasibility of placing the LRT on the Homer Hadley Floating Bridge and approach spans. It is not intended for any other purpose or as the basis for any final design or construction issue associated with this project	Calculation No.:TM-05	
	Rev No.: 0	Sheet 61 of 62

#### 4. Conclusions/Recommendations

Three-dimensional finite element model of Lines L and M were developed. Mode shapes and frequencies were obtained. Dead load analysis, response spectrum analysis, and a pushover analysis were conducted. The target displacements were obtained from the response spectrum analysis and were used in the pushover analysis to obtain the demand values. This was a preliminary analysis of the West approach and should be used for any final design. From this preliminary analyses, drift and strain values were extracted and compared with drift strain limits. Although the drift limits are satisfied, the strains are not in several piers. Mast piers experienced strain higher than the strain limit. The followings are some of our recommendations:

1. It is suggested that additional mass and possibly stiffness of the adjacent structure at Pontoon pier be added.
2. The ground level needs to be clearly defined for all piers.
3. The split columns at pier 3 need to be examined further to assure proper detailing at the connection of the split and solid section.
4. At the spread footing the piers are modeled with fixed base. It is suggested that soil impedance be used at the spread footings.
5. A more detailed study by a geotechnical engineer is required to establish a better estimate of the depth of the point of fixity
6. It is recommended that piles be modeled with nonlinear plastic material.
7. If still pushover analysis is to be used, it is important to include a reverse pushover analysis as well, because the structure is not symmetric.
8. It is recommended that a nonlinear time-history analysis be used for the next phase of the analysis. What presented in this tech memo is a preliminary analysis. In the nonlinear time-history analysis, the soil springs should be modeled along the height of piles and ground motions should be applied to the ground nodes of the soil springs. Wave passage effect and coherency would be included in the ground motions in such approach.

#### 5. References

1. INCA Technical Memorandum 6/13/2008: “Sound Transit East Link Phase 2 – IRT Issue C – seismic Vulnerability and Seismic Retrofit of Approach Spans and Transition Span

<b>I-90 Homer Hadley Floating Bridge – LRT Impacts</b>		<b>SC Solutions</b>
<b>Subject/Description: Seismic Vulnerability Assessment of the West Approach and Transition Spans</b>	Originator: Joyce Kin-Yan Lee	Date: 8/6/2008
	Checked: Hassan Sedarat	Date: 8/6/2008
Disclaimer: The analysis in this technical document is preliminary and is strictly to be used as advice in determining the feasibility of placing the LRT on the Homer Hadley Floating Bridge and approach spans. It is not intended for any other purpose or as the basis for any final design or construction issue associated with this project	Calculation No.:TM-05	
	Rev No.: 0	Sheet 62 of 62

2. ADINA, Automatic Dynamic Incremental Nonlinear Analysis, ADINA R&D.
3. North Light Rail, North Link and Airport Link Design Criteria Manual, November 2005
4. As-built drawings – SR 90 3rd Lake Washington Floating Bridge, Approaches and Transition Spans
5. I-90 West Shore of lake Washington Response Spectrum Site Class D, 1000-yr return period earthquake to be used for retrofit of existing structures, email from Tom Ballard dated 6/11/2008.
6. SPEMC, an in-house section analysis program, SC Solutions.

## PROJECT MEMORANDUM

---

I-90 Homer Hadley Bridge - Wave Climatology

TO: File  
DATE: 30 July 2008  
FILE No.: 08035.01  
FROM: Tom Bringloe

---

- References:
1. The Glosten Associates, Inc., Wave Loading Analysis of Lake Washington Bridges Volume 2, Analysis and Results, New I-90 Floating Bridge, May 1983.
  2. Shore Protection Manual, Coastal Engineering Research Center, Department of the Army, Vicksburg, Mississippi, 1984
  3. SWAN User Manual, Delft University of Technology, Environmental Fluid Mechanics Section, Delft, The Netherlands.

The previous wave climatology predictions for the I-90 bridge site were performed in 1983 [1]. The southerly wind storm waves were applied to the HMM bridge because, at that time the original LVM bridge was an aging structure which was expected to be replaced at some point, leaving the HMM bridge unprotected. Now the HMM bridge is sheltered from southerly wind and waves by a new bridge which can be expected to have the same or longer life.

Several other things have changed since the 1983 work was done.

- We have now developed a much longer record of Lake Washington storm wind events, allowing better statistical predictions of extremes. This is especially true of northerly winds since severe north storms occur infrequently, roughly once every 20 years.
- In 1983 we were using a wave hindcasting program developed by the US Army Corps of engineers. In 1984 they revised their methodology [2] to include an air-to-water temperature difference correction, where air colder than the water the water surface causes larger waves to develop. In the Puget Sound region, the rare northerly storms are “Arctic outbreak” events, where very cold air from the Canadian plains “spills” down the Fraser River valley and into Western Washington. This causes high winds and usually blizzard-like conditions. So the temperature correction is an important revision to the methodology.
- There have been a number of subsequent advances in the science of wind-wave hindcasting. We now use program SWAN (Simulating Waves Nearshore) developed at Delft University of Technology [3]. The body of water is divided into grids and the geometry of the boundaries and water depth is defined. A wind field is defined and the progressive development of wind waves is simulated numerically through the grid.

Given all these changes, it was thought that the north wind wave climatology should be revisited.

A SWAN model was developed recently for use on the SR-520 bridge analysis. It was a simple matter to take the model developed for south wind effects on the 520 bridge and just reverse the wind direction to look at north wind effects on the HMH bridge at the I-90 site. The wave condition is defined as a frequency spectrum consisting of waves of many heights and frequencies, but characterized by two values: a “significant height”  $H_S$  and a “Peak Period”  $T_P$ . The results, compared to the waves used in the 1983 analysis, are as follows

---

Storm Condition	Significant wave height $H_S$	Peak Period $T_P$
1- year north	0.9 feet	2.1 seconds
1-year south (per 1983)	2.15 feet	2.71 seconds
100-year south (per 1983)	3.37 feet	3.40 seconds

---

The responses (motions and loads) of the bridge to waves decrease linearly with wave height, but also decrease markedly with decreasing period (higher frequency). So in fact the 1-year recurrence north storm is not expected to have an impact on operations.

---

Note: The work reported in this memo was performed only for the purpose of forming general opinions, and is not intended for design work product.

---

Technical Memorandum

**Title: Impact of Stray Current on Remaining Service Life**

Washington State Legislature, Joint Transportation Committee  
Independent Review Team

*This technical memo discusses the initiation of corrosion as a consequence of stray current and its impact on the remaining service life of the floating structure.*

**Prepared for:**

**Washington State Legislature  
Joint Transportation Committee**

*August 20, 2008*

**The analysis in this technical document is preliminary and is strictly to be used as advice in determining the feasibility of placing the LRT on the Homer Hadley Floating Bridge and approach spans. It is not intended for any other purpose or as the basis for any final design or construction issue associated with this project.**

***Prepared by: Ali Akbar Sohangpurwala***

*Ali Akbar Sohangpurwala*

CONCORR, Inc.  
Sterling, Virginia





# INTRODUCTION

## What is Stray Current

The conceptual design of the light rail as proposed by Sound Transit utilizes overhead catenary wires to provide electrical power to the light rail. The running and restraining rails (tracks) would serve as the negative return for the power supply. The power would be supplied by substations at either end of the bridge. In this particular design, stray currents can be generated both from the catenary wires and the tracks. This memo only deals with stray currents resulting from the use of the tracks as a negative return.

Electrical current always flows across a voltage differential through all materials; however, the magnitude of the current flow is directly proportional to the voltage differential and inversely proportional to electrical resistance offered by the material. For example, if a 12 volt differential is applied across a conductive element with a 1  $\Omega$  resistance, 12 amperes or current will flow. If the same 12 volts is applied across an insulator with 1,000,000  $\Omega$  (1M $\Omega$ ) resistance, then 0.000012 amperes (12  $\mu$ amps) of current will flow; this is a very small current, and in many applications is be considered negligible or zero. Whenever an electrical current is offered two or more alternative paths, the current will flow through all alternative paths. The flow of current in each path will be dictated by the resistance of the path; e.g., the lower the resistance the higher the current through that path.

The current flow in the light rail tracks will generate a track-to-earth voltage that can drive an electrical current through track attachments, reinforced concrete pontoons, and lake water back to the substation. This current flow is designated as stray current. It will pass through the rail fasteners, plinth, plinth fasteners, and the cementitious overlay to enter the reinforced concrete pontoon deck. The rail fasteners and plinth and plinth fasteners can be designed to provide a very high resistive path, and thereby reduce the amount of current that can flow through for a given track-to-earth voltage. The cementitious overlay and the pontoon deck will also provide some insulating properties. The integrity of these design elements has to be maintained, for stray currents to remain within the design parameters. Degradation of the rail fasteners, plinth, or plinth fasteners can result in much higher levels of stray current. Insulation on the rail and the plinth fasteners can be expected to degrade with time, thereby increasing the level of stray current. Presence of moisture and cracks in the plinth where moisture can collect will decrease its resistivity. The plinth fasteners, if they make contact with any reinforcing steel in the pontoon deck, will provide a direct path for stray current that manages to reach down to the level of the plinth fastener. Even at the design level performance of all elements, some current will flow through to the reinforced concrete pontoon deck. Once this current enters the deck, the reinforcement (post-tensioning and conventional) will offer a very low resistance path as all reinforcements in the deck are metallic. The majority of the current will tend to flow through the reinforcing steel down and, when it reaches at or below the waterline, the majority of that current

can be expected to flow out to the lake water and back to the substation. The lake water would offer a low resistance path back to the substation.

## **HOW STRAY CURRENT IMPACTS CORROSION OF REINFORCING STEEL**

Electrical current flow is a measure of the transfer of electrical charge. This transfer of charge in different mediums occurs differently. In a metallic conductor, the charge transfer or current flow occurs due to the movement of electrons. In an electrolyte, the transfer of electrical charge occurs due to the movement of ions. Concrete is an electrolyte, as the pore water solution in concrete contains ions.

For the electrical current to transfer from concrete to reinforcement, or from reinforcement to concrete, a process to convert ions to electrons or electrons to ions must occur. This process is termed an electrochemical process, in that charge transfer occurs through a chemical reaction. There are two different types of chemical reactions that must occur, an anodic and a cathodic. These reactions occur at the metal concrete interface. At the anodic site, metal dissolves into the pore water or solution (i.e., corrodes). This results in a positive metallic ion in the solution, and excess electrons in the metal. The ions and electrons generated in this reaction can now conduct electrical charge in the electrolyte and the metal. At the cathodic reaction sites, the chemical reaction combines ions in the solution with the electrons in the metal to produce a neutral chemical species. The two chemical reactions, anodic and cathodic, allow an electrical current to exit and enter reinforcement in concrete, respectively. Electrical current exits reinforcement at the anodic sites and enters the reinforcement at the cathodic sites.

### **Corrosion Impact of Stray Current**

An electrical current flowing in a reinforced concrete structure will result in corrosion of the reinforcement at the sites where the current exits the reinforcement to enter the concrete. The rust generated during the corrosion process is 7 to 10 times more voluminous than the reinforcing steel. The expansion resulting from the corrosion process generates tensile stresses in concrete that results in cracking. Progressive cracking develops delaminations that subsequently spall. Steel section loss also occurs during this process. However, spalling is more likely to occur prior to significant steel section loss. Once the reinforcement is exposed in a crack or a spall to the lake water, it will offer a much lower resistive path and more stray current will flow through it. With time, significant section loss can be expected at such sites. The rate of corrosion is directly proportional to the amount of current flow. If an ampere of current flows constantly out of the reinforcement for a period of one year, 22 lbs. of steel would be lost due to corrosion.

Corrosion due to stray current will occur at primarily two different locations on the pontoons; the top mat reinforcement or post-tensioning ducts in the deck, and the reinforcement in the outer walls below the waterline. When the current enters the pontoon deck, it will first encounter the

top mat reinforcement or the post-tensioning ducts. If the top mat reinforcement or the post-tensioning duct(s) is discontinuous to the rest of the reinforcement, the current will have to exit it to get to the next level of reinforcement, thereby generating corrosion of the top mat reinforcement or the post-tensioning duct. This can occur at any location the current encounters a discontinuous metallic embedment. Limited testing by Sound Transit has indicated that the reinforcement in the pontoons and the anchor cables are continuous to some degree. The results of this testing do not provide specific information on the continuity of the epoxy-coated top mat reinforcement or the continuity of the post-tensioning ducts. The continuity observed could simply be a function of all-black reinforcement being continuous in the pontoon walls, the anchors being continuous to the black reinforcing steel in the walls, post-tensioning conduits being continuous with the black reinforcement, some of the epoxy-coated rebars being continuous with the post-tensioning conduits and the black reinforcement, or any other combination.

There are two impacts of stray current on the top mat epoxy-coated reinforcement; cathodic disbondment at the site of current flow into the epoxy-coated rebar, and corrosion at sites where current discharges from the epoxy coated rebar. Although epoxy coating provides a high resistance to electrical current, some stray current will flow through pin holes and damage the epoxy where the black reinforcing is exposed. When the current enters the epoxy-coated rebar, a cathodic reaction will occur at that site, resulting in cathodic disbondment of the coating in that area. However, it should be noted that research [1] has indicated that a reduction in adhesion of the coatings will occur with age under normal use, and that 50% of epoxy coating can be expected to suffer some level of adhesion reduction within 6 to 10 years of placement in concrete. As the pontoons have already been in service for much longer than 10 years, a certain level of adhesion reduction and/or complete disbondment of the coating can be expected to have occurred. Stray current can increase the rate of adhesion reduction or disbondment. It is believed that a high level of quality control and assurance was exercised during the construction of the pontoons and, therefore, much of the epoxy-coated rebars can be expected to be discontinuous with the remaining reinforcement in the pontoon deck slab. Thus, stray current pickup by the epoxy-coated rebar most likely will result in corrosion. The impact of corrosion of the epoxy-coated rebars on the remaining service life will be dictated by the amp-hours of stray current that flows through the pontoon deck slab.

With regards to the current that flows down the reinforcement to below the waterline, it will exit the reinforcing steel and travel through concrete cover to the lake water. Corrosion of the reinforcing will occur at those locations, and subsequent cracking, delamination, and spalling can be expected. The level of cracking, delamination, and spalling will depend on the stray current density (amp-hours per square feet of steel surface area) exiting the reinforcement.

Depending on the electrical resistances, the stray current can also flow through anchor cables that are continuous to the reinforcing steel and exit the cables underwater to flow back to the substation, resulting in corrosion of the anchor cables.

## Development of Concrete Damage and its Relationship to Stray Current

Time to damage is the time required for sufficient corrosion to have occurred to generate the required amount of rust (or expansion) to produce cracking and or delamination of the concrete ( $T_p$ ).

The rate of accumulation of rust (i.e., rate of expansion) can be estimated by the density of stray current flowing out of the steel. The amount of expansion generated by the products of corrosion is very dependent on the level of oxidation of the corrosion product. There are several techniques available to estimate the accumulation of rust or section loss of steel (section loss of steel is directly proportional to the amount of rust generated). However, our goal is to determine the time when cracking, delamination, or spalling occurs that presents us with a series of significant problems in quantifying the time to failure:

1. There is no easy way of converting section loss to cracking rate.
2. Cracking patterns will be a function of steel layout and shape of the reinforced concrete member.
3. Loading will affect cracking rate, especially live loading.

There are two different approaches to determining the time to damage based on the flow of stray currents. Both of these approaches were developed to determine the time to damage for corrosion on reinforcement due to environmental exposure. However, the corrosion rate in these equations is much easier to calculate as it can be substituted by the stray current density.

One quantitative equation for converting section loss to cracking has been developed by Rodriguez et. al. [2].

The crack width  $W$  at the concrete surface is

$$W = 0.05 + \beta(X - X_0) \quad \text{for } 0 < W < 1\text{mm} \quad (1)$$

where

- $\beta = 0.01$  for top cast steel and  $0.0125$  for bottom cast steel
- $X$  = bar radius decrease due to corrosion to produce crack width  $W$
- $X_0$  = bar radius decrease due to corrosion to induce crack initiation (at surface)
- $X_0 = 83 + 7.4c / \phi - 22.6f_{c,sp}$

where  $c =$  cover

$\varnothing =$  bar diameter

$f_{c,sp} =$  tensile splitting strength of concrete

The tensile strength of concrete  $f_{c,sp}$  can be derived from its compressive strength  $f_c$  [3].

$$f_{c,sp} = 0.12(f_c)^{0.7}$$

First, to calculate time to cracking, Equation 1 is used to determine the reduction in the bar radius for a given crack width. Density of stray current can then be used to determine when such a reduction will occur.

Liu et. al. proposed a different approach, which is based on the mechanics of the generation of rust and the resulting stress in the concrete [4]. They idealized a rebar in concrete as a thick walled cylinder and derived that the critical amount of rust required to produce a crack can be modeled by:

$$W_{crit} = \rho_{rust} \left( \pi \left[ \frac{Cf_i}{E_{ef}} \left( \frac{a^2 + b^2}{b^2 - a^2} + \nu_c \right) + d_0 \right] D + \frac{W_{st}}{\rho_{st}} \right) \quad (2)$$

Where:  $W_{crit} =$  critical volume of corrosion product required to induce a crack  
 $\rho_{rust} =$  density of rust  
 $C =$  clear concrete cover  
 $f_i =$  tensile strength of concrete  
 $E_{ef} =$  effective elastic modulus of concrete  
 $a =$  inner radius of the thick walled cylinder (clear concrete cover  $- d_0$ )  
 $b =$  outer radius of the thick walled cylinder (clear concrete cover  $+ D/2$ )  
 $\nu_c =$  Poisson's ratio for concrete  
 $d_0 =$  thickness of the porous zone around the steel/concrete interface  
 $D =$  diameter of the rebar  
 $W_{st} =$  mass of steel corroded  
 $\rho_{st} =$  density of steel

They derived that the rate of production of rust could be modeled by:

$$W_{crit}^2 = 2 \int_0^t 2.59 \times 10^{-6} \left( \frac{1}{\alpha} \right) \pi D i_{corr}(t) dt \quad (3)$$

Where:  $\alpha$  = molecular weight of steel/molecular weight of corrosion products  
 $i_{corr}(t)$  = rate of corrosion as a function of time  
 $t$  = time

When stray current density is used in the place of  $i_{corr}$ , the integral simplifies as stray current density in amp-hours is already an integral of current flow.

First, the critical volume of rust required to generate a crack is calculated from Equation 2. The time required to generate that much rust is then obtained by solving Equation 3. This model was validated against laboratory slabs. The above model indicates that the time to cracking is dependent on physical properties of concrete (tensile strength and Poisson's ratio), clear concrete cover, rebar diameter, and corrosion rate; or in this case, the density of stray current.

### **Impact of Stray Current Generation on Remaining Service Life of the Floating Structures**

Sound Transit has estimated stray current that may be generated due to the design track-to-earth voltages that may be generated during the operation of the light rail. Their calculations indicate that for 4 hours a day around 7.33 milliamperes, and 16 hours a day 5.876 milliamperes of stray current, can be expected to flow from a 500 feet of rail. The metal loss resulting from this stray current over a 70-year period would amount to 9.715 pounds. Similar calculations for a failed fastener indicate that, in a month, 16.361 amp-hours (0.53 amp-hours in a day) of stray current may be generated if concrete resistivity is 10,000  $\Omega$ -cm.

Considering that the surface area of the reinforcements in exterior walls of the pontoons is quite large, if all of the design stray current was uniformly distributed over that entire surface area, significant cracking and concrete damage may not occur. However, the distribution of current will depend on the density of reinforcement in the walls, the presence of cracks in the concrete, and the electrical path offered by the anchor cables and other metallic elements that project out of the exterior walls into the lake water. If cracks exist on the exterior walls and they reach to the depth of the reinforcement, a lower resistive path will become available and stray current will favor it, thereby concentrating more stray current in these areas, which could result in more expedient corrosion damage. As the proposed tracks are located on the south side of the structure, the majority of the stray current is likely to flow out of the southern exterior walls of the pontoons and the bottom slab.

In the case of a failed fastener, as indicated by Sound Transit calculations, a much larger current can flow in a localized area. This current is more likely to be concentrated and can cause damage to the exterior wall concrete much sooner. The estimates of stray current flow into concrete were based on the assumption that no collector mat will be used. Therefore, these are the worst case scenario.

Although the estimated stray current values seem small, if they are concentrated in certain areas, the resulting damage may limit the remaining service life. No protocol is available to ascertain where, if any, such concentrations may arise; some approximations can be used to determine where stray current may concentrate by using the density of steel in the pontoon walls, and randomly locating cracks on the side and the bottom walls. One such protocol is discussed below.

## **Analysis of Stray Current Flow in the Reinforced Concrete Structure**

It is proposed that the flow of stray currents in the pontoon can be modeled using finite element techniques in conjunction with a transmission line model for current flow. Sohangpurwala et. al. had proposed a similar approach for estimating the flow of current in a cathodic protection system [5]. This approach also incorporates the non-linear behavior of polarization of the metal as current enters or exits the metallic member. For stray current analysis, the non-linear behavior may be ignored, as our goal would be to estimate the order of magnitude of the stray current and the locations from which it is likely to discharge.

The approach proposed by Sohangpurwala et. al. did not incorporate the flow of current in the lateral direction, and only considered current flow in the vertical direction as it was primarily proposed for analyzing bridge deck cathodic protection systems. In this approach, the lateral flow of current was only considered in the anode material. This approach can be easily modified to include the lateral flow of current and can be applied to stray current analysis.

This approach subdivides the element subject to analysis into finite elements, and applies Ohm's and Kirchhoff's law to each finite element. The track-to-earth voltage is represented in the boundary elements. The resistance of each finite element is calculated from the resistivity of material it represents in the model. The accuracy of this approach will depend on how well the reinforcing steel in the pontoon deck slab and walls, plinth fasteners, reinforcement in the plinth, and rail fasteners are modeled.

In addition to modeling the design level stray current, one can also model what the degradation of one or more rail and plinth fasteners, or the degradation of any element that could increase the flow of stray current, and its impact on the magnitude and the distribution of stray current.

The results of such a model can then be combined with cracking models discussed above to estimate the time to cracking for various options, such as design level stray current, failure of one or more components, etc. Such an approach will not only provide the information on the time to cracking due to stray current, but also from where stray currents are most likely to exit from.

Considering the complexity of the modeling and the project time and budget constraints, actual modeling was not performed. If budget and time allows, such modeling can provide significantly valuable information for the project.

## REFERENCES

1. Sohahngpurwala, A.a.S., W., *Verification of Effectiveness of Epoxy-Coated Rebars*. 1998.
2. Rodriguez, J., Ortega, L.M., Casal, J., and Diez, J.M. *Corrosion of Reinforcement and Service Life of Concrete Structures*. in *7th International Conference on Durability of Building Materials and Components*. 1996. Stockholm.
3. Neville, A.M., *Properties of Concrete*. 4th ed. 1995, Harlow, UK.
4. Liu, Y., *Modeling the Time-to-Corrosion Cracking of the Cover Concrete in Chloride Contaminated Reinforced Concrete Structures*, in *Civil Engineering*. 1996, Virginia Polytechnic Institute and State University.
5. Sohahngpurwala, A.a.S., W., *Designing Cathodic Protection Systems with Optimal Current Distribution*, in *Corrosion 1992*. 1992, NACE: Nashville, Tennessee.



August 14, 2008

Mr. Thomas Ballard, P.E.  
SC Solutions, Inc.  
Chief Engineer  
1261 Oakmead Pkwy  
Sunnyvale, CA 94085

**RE: I-90 Independent Review Team  
Resistivity, Unit Weight, & Absorption Test Results**

Dear Mr. Ballard:

CONCORR, Inc. received a total of three cores from Mayes Testing Engineers. The cores were collected from the Homer Hadley Bridge. All of these cores were collected from the walls inside the pontoons. Of the three cores, two are from Pontoon F. One of these cores was found in Cell C5 of the pontoon (labeled F/C5) and had resulted from a previous coring performed to install a fiber optic cable. The other core was collected from Cell C11 in a repair area (labeled F/C11). It is believed that the repair was performed to correct a construction defect. This core contained a cold construction joint which was not fully bonded. The third core was collected from Pontoon A, Cell H4 (labeled A/H4).

After documentation of the initial core dimensions and weight, all cores were subjected to 3 hours of vacuum, 1 hour of submersion in tap water under vacuum, and 18 more hours of submersion in tap water. Upon completion of this conditioning, weight and electrical resistance of the cores were measured. Electrical resistance was measured using two pins and a Nilsson 400 Resistivity meter.

The core that contained a construction joint (F/C5) was cut into two samples, one that represented the original concrete and the other to represent the repair material. It was not possible to distinguish the two materials and therefore the two samples are labeled by their surface finishes.

Two more cycles of conditioning were then performed on the four samples and after each cycle, weight and resistance measurements were made. The samples were then weighed in water to

obtain their volume. The samples were then allowed to dry in laboratory for 4 days. The temperature in the laboratory is estimated to have varied from 70 to 80° F and humidity from 50 to 70 percent. Another set of electrical resistance measurements were collected.

The results of the testing are tabulated in Tables 1 and 2.

**Table 1: Resistivity Test Results**


Pontoon	Cell	Diameter (inches)	Cut Length (inches)	Resistance After Water Saturation, Ohms			Average Resistivity Ω-cm	After 4 days of Drying, Ohms	Resistivity Ω-cm
				Day 1	Day 2	Day 3			
F	C5 (with disbondment)	2 15/16	6 1/8	3,600			10,118		
	C5 - Finished end	2 15/16	3	3,000	2,700	2,700	16,066	4,100	23,526
	C5 - Painted end	2 15/16	2 3/16	1,900	1,650	1,500	13,247	2,500	19,673
F	C11	2 15/16	6 1/8	4,900	3,500	3,400	11,054	6,150	17,284
A	H4	1 1/2	6 15/16	23,000	18,500	17,500	12,724	35,000	22,645

**Table 2: Unit Weight and Absorption**

Pontoon	Cell	Diameter (inches)	Cut Length (inches)	Weight - Dry (g)	Weight - Soaked Day 1 (g)	Weight - Soaked Day 2 (g)	Weight - Soaked Day 3 (g)	Weight in Water (g)	Unit Weight, lbs/ft <sup>3</sup>	Total Water Absorption, %
F	C5 (with disbondment)	2 15/16	6 1/8	1,704.90	1,715.30					0.61%
	C5 - Finished end	2 15/16	3	835.05	843.70	845.40	845.90	485.90	149.30	1.04%
	C5 -Painted end	2 15/16	2 3/16	608.89	628.22	629.74	630.20	356.70	150.72	3.17%
F	C11	2 15/16	6 1/8	1,669.60	1,685.00	1,689.20	1,691.30	974.60	149.97	0.92%
A	H4	1 1/2	6 15/16	655.64	662.80	664.16	664.57	370.80	143.69	1.09%

The resistivity results are very much in line with what we were expecting. If you have any questions please do not hesitate to contact me.

Yours Sincerely,

  
 Ali Akbar Sohhangpurwala  
 President

# I-90 HOMER HADLEY FLOATING BRIDGE

## Independent Review Team - Light Rail Train Impacts



## ***APPENDIX C: MEETING NOTES***

---

**SC SOLUTIONS** In Association with

 **THE GLOSTEN ASSOCIATES**  
Consulting Engineers Serving the Marine Community

 **RUSSELL CORROSION CONSULTANTS, INC.**  
Columbia, Maryland  
Garden City, New York

 **CONCORR, Inc.**  
CONCRETE CORROSION SPECIALISTS

## **Appendix C – Meeting Notes**

### **Independent Review of LRT Feasibility, I90 Homer Hadley Floating Bridge Site Visit and IRT Meetings of April 21, 22, 23**

#### Independent Review Team (IRT)

Tom Ballard (SC Solutions) – Team Leader  
Tom Bringloe (The Glostén Associates)  
Steve Nikolakakos (Russell Corrosion Consultants, Inc.)  
Chuck Ruth (SC Solutions)  
Ali Akbar Sohaghpurwala (CONCORR, Inc.)

WSDOT Contact – Theresa Greco

ST Contact – Don Billen

JTC Contact – David Forte

#### Monday, April 21

#### A. Introductions and Pre-Site Visit Discussion (8AM to 9AM)

Attendees: IRT

David Forte – Joint Transportation Committee (JTC)

Theresa Greco – WSDOT

Kelly Jones – WSDOT

Archie Allen – WSDOT

Discussion: Theresa

- Sound Transit (ST) and the Washington State Department of Transportation (WSDOT) to provide the information the IRT needs for the study
- Independence of study must be assured
- There is a lot of stakeholder interest in this study
- There are proponents and opponents to LRT on the Homer Hadley Bridge
- The study must be transparent. The basis for all recommendations should be obvious.
- Document all communications with outside agencies or stakeholders
- Any calculations performed by the IRT, in support of findings, will become part of the public record

Discussion: Tom Ballard

The IRT is not performing analysis that will be used by ST for the LRT design (should have reference to this in final report)

ST Consultant Team:

- Lead Consultant – CH2M Hill
- Subs: Parsons Brinkerhoff (Planning), PTG (Track Works), INCA (Structural)

B. Field Trip to HH Bridge and to ST yard in Seattle (9AM to 2:15PM)

The IRT toured the HH Bridge. The following HH Bridge facilities were visited and viewed:

- Roadway Deck Pontoon
- Anchor Gallery
- Pontoon Bolted Joint
- Cross (West End) Pontoon
- 4' Expansion Joint and Transition Span Bearings at West End
- Pontoon Post-Tensioned Joint
- Bridge-supported utilities and storm drainage system

Jugesh Kapur and Tony Messmer (WSDOT Bridge Office), and Archie Allen (WSDOT NW Region Maintenance Manager) participated in the field trip and provided answers to the IRT relating to the design, construction, and maintenance of the HH Bridge.

The IRT then visited the Sound Transit yard where “stray current” tests were being performed on a rail section with fasteners. Sound Transit’s stray current expert, Ed Wetzel (PCS), explained the test procedure. Ed answered questions from the IRT and there was considerable discussion about stray current issues.

C. Q & A Meeting with WSDOT (2:15PM to 5PM)

Attendees:

Jugesh Kapur & Tony Messmer (WSDOT Bridge Office) and Archie Allen (WSDOT NW Region Maintenance Manager) were present to answer questions. Other attendees were the IRT, Theresa Greco, Dave Forte, Don Billen, Kelly Jones, Dave Becker (WSDOT)

The following issues were discussed:

- The IRT requested information from the WSDOT Bridge office on the seismic risk/vulnerability of the HH Bridge and approaches.
- ST new facility (bridge) earthquake design criteria requires “no collapse” for a 2500-year earthquake, and full serviceability and easily repairable damage for an 150-year earthquake.
- The current WSDOT bridge inspection frequency for the HH Bridge are every year for routine inspections and every two years for in-depth inspections. Anchor cables are given a high priority.

- IRT asked WSDOT what their policy is for an acceptable level of stray current on the HH Bridge. Jugesh indicated that WSDOT has no standard established and expects the stray current experts to develop a range of stray current acceptance criteria for WSDOT to consider. Jugesh also indicated that WSDOT expects to achieve 75 to 100 years of remaining life for the HH Bridge based on the current configuration (no LRT).
- The current ADT on the HH Bridge is 60,000.
- Salt is not currently used for deicing the HH Bridge roadway deck. There was discussion about the fact that use of salt for deicing could significantly reduce the life of the HH Bridge.
- The issue of “lightning mitigation” was brought up by the IRT. It was suggested that this issue be brought up in tomorrow’s IRT meeting with the ST team.
- General discussion of the HH Bridge existing electrical system and the expected electrical systems that would be required for LRT
- Weight mitigation is a concern for WSDOT on the HH Floating Bridge. Loss of freeboard is not tolerable. In addition, the weight mitigation has to be engineered such that the floating bridge does not rotate or list in one direction or the other (this could have a major impact on stormwater drainage). It was stated that weight mitigation should not have any significant influence on the mass moment of inertia of the bridge.
- The current proposal for lane reconfiguration on the GP Traffic portion of the HH Bridge will require that a “screen” be placed on the existing barrier between traffic and the bike lane (to mitigate the risk of road debris in the bike lane).
- Illumination of the roadway deck may be required by FHWA as part of the lane reconfiguration proposal.
- The IRT brought up the issue of the \$ impact of loss of use of the HH Bridge. WSDOT said they would look at this issue and provide a number.
- The estimated LRT installation schedule (if approved) is 2013 to 2014 at the earliest.
- Archie Allen indicated that there will be significant operational and maintenance issues associated with the addition of LRT to the Homer Hadley bridge, such as: turnaround on West shore; daily access across tracks; intrusion alarms on access hatches; maintenance staffing issues; OCS support conflict with anchor cable replacements; stray current detection/response; bottom line – protection of the HH Floating Bridge.

- The IRT indicated that stray current detection, monitoring, system failure response and related issues need to be resolved. In addition, a stray current monitoring system should also be used for the existing anchor cable cathodic protection system.
- The IRT and WSDOT agreed that reinforcing steel and associated concrete cracking that could be generated by stray current is a major concern for the HH Floating Bridge and could have a major impact on the remaining life of the bridge.

Documentation Provided to the IRT at this meeting:

1. ST LRT details for plinth and OCS pole attachments (by ST)
2. Pontoon structural details and original floating bridge design criteria (by WSDOT, e-mail)

Meeting adjourned at 5PM

Tuesday, April 22

Attendees: IRT  
 WSDOT: Theresa Greco, Kelly Jones, Tony Messmer, Jugesh Kapur, Archie Allen  
 ST: Sue Comis, Ed Wetzel, Bob Sanders, Dave Stensby, Dan Russell, Steve Kambol, Ahmet Ozkan, Isam Awad, Don Billen, Roger Koester  
 JTC: David Forte  
 Others: Rick Johnson (KPFF)

General Discussion initiated by IRT

The IRT believes that “remaining life” and seismic design criteria need to be developed and adopted by ST/WSDOT for the LRT project. The remaining life of the bridge will allow the stray current and corrosion experts a time frame for determining the accumulation and effects of stray current on the capacity and life of the HH Floating Bridge. The IRT provided examples/options for possible stray current mitigation. The IRT suggested that ST propose stray current acceptance criteria for WSDOTs consideration. Some stray current will be present regardless of mitigation, but it can be minimized. It is also likely that there will be an occasional breakdown of the stray current mitigation elements. Identification and early response to repair the breakdowns will be key to protection of the bridge. ST believes that there could be stray current issues with the existing cathodic protection system on the HH Floating Bridge.

The IRT also believes that maintenance and operation of the LRT on the HH Floating Bridge is a major issue that needs further discussion and development by ST and WSDOT, and is just as important as any LRT design issue.

#### ST LRT Regional History Presentation

- Don Billen provided a discussion of the project background, including the history of Sound Transit and development of the LRT program currently being implemented. Interstate 90 was determined to be the primary East/West LRT corridor link between Seattle and the communities East of the HH Floating Bridge. In 2004, the decision was to move forward with the idea of placing LRT on the “reversible lane” portion of the HH Floating Bridge (Center Roadway) and add an HOV lane to the WB lanes. There is a long term commitment to putting LRT on this corridor.

#### ST Technical Presentation

- Roger Koester provided a visual “Powerpoint” presentation of their LRT proposal for the HH Floating Bridge along with a hard copy handout of this presentation. The discussion included a brief summary of the 2001 Structural Feasibility Study and the 2005 LRT Load Test Study. Dave Stensby provided a conceptual discussion of the rail bridge/expansion joint design. The IRT indicates that a rail bridge/expansion joint this unique should undergo “prototype testing” at least prior to construction/installation to assure desired performance and identify any impacts to the HH Floating Bridge and approaches. The IRT also indicated that design criteria for rail bridge/expansion joint distortions relative to rider comfort needs to be established. Other systems such as BART and IMAX incorporate this type of criteria into their designs.
- ST indicates that the normal LRT speed across the HH Floating Bridge will be 45 MPH and that the speed across the major expansion joints at the ends of the bridge will be 25 MPH. This speed can be controlled. A surge of current will be put into the rail to accelerate the LRT after the slowdown (about 500 amps per vehicle according to Ed Wetzel). There is a “load flow” report that provides more detail.

Ed Wetzel (ST Stray Current Expert) provided a presentation on LRT stray current. The following issues we discussed:

- ST indicates that unless there is a stray current mitigation system failure, there should be little or no harm to the HH Floating Bridge.
- ST plans on looking at possible insulation breakdowns and determine the level of stray current.



- Theoretical calculations show 17.9 grams of steel consumption per 1000 feet of bridge for 100 years”. This is based on a stray current of 80 milliamperes per 1000 feet of bridge for a wet track condition. The IRT will verify that when we receive the calculations.
- Newer rail fastener systems are much less susceptible to water intrusion and corrosion damage.
- The effect of stray current on the proposed rail bridge/expansion joint system has yet to be studied.
- The IRT stated that they are generally looking for long-term performance of rail fastener insulation. The needs to be a monitoring system capable of detecting fastener insulation breakdowns for quick identification and rapid repair. Breakdowns are likely over the life of the bridge and should be part of the stray current design and mitigation plan.
- Tim Benson (WSDOT Bridge Preservation Office Electrical Engineer) called in to answer questions about the existing cathodic protection system on the HH Floating Bridge. The IRT asked some questions that Tim had to look in his files to answer. He indicated that he would respond to the IRT by e-mail (and did that evening).

*Below are Tim Benson’s responses to IRT questions:*

*1. Each rectifier has an equipment ground conductor routed to it along with the 120 volt hot leg and a neutral ( the green, black and white conductors shown in the photo).*

*2. The green equipment grounding conductor ground wire is bonded with a compression lug to the interior frame of the rectifier as you can see in the photo.*

*3. The equipment bonding is continuous. The equipment grounding conductor at the rectifiers is #12 awg stranded copper with a green insulation. It is connected to all of the other equipment ground conductors in it's pontoon on a ground bus in the lighting and receptacle panel which we have designated P2 Panels. There is one P2 panel in each pontoon. The neutral is connected to all the other neutrals in the pontoon on an isolated neutral bus. The neutral and ground bus are bonded together in a P1 panel. There is one P1 panel for every three pontoons. The design plans have not been as built so I do not know what size conductor connects the P2 panel equipment ground buses and neutral buses to the P1 panel. This would need to be field verified. The P1 panels are bonded to a pair of transformers with a #2 awg wire.*

*4. The entire Homer Hadley Bridge is powered from a 15KV rated switch on the Seattle side of the bridge. A single phase 14.7 kV feeder daisy chains through load break elbows to a redundant pair of step down transformers in pontoons B, E, H, K, N and Q. A pair of #2 awg aluminum conductors are identified in the plans as a neutral and ground conductor. They are shown on the plan as terminating on separate ground and neutral buses inside the 15kV switch which I know is not the case. Both of these conductors are bonded together and connected to ground rods.*

*5. Each rectifier neutral is connected to the other two rectifier neutrals feed from each P1 panel and the neutrals of each of the P1 panels are bonded together through the ground conductors.*

*This response is based on our in house documentation which has not been verified as "As Built" and should be field verified before any action is decided upon. If you are planning to perform any testing which may affect the operations of the electrical systems on this bridge we would appreciate it if you would provide us a copy of your proposed test procedure.*

- The IRT suggests that ST look at the very worst possible stray current scenario and resulting reinforcing corrosion with the two following conditions:
  - Long term section loss
  - Short term breakdown of insulation (not detected for 1 year)The purpose of this approach is just to get some baseline idea of what the worst impact to bridge life would be.

Ahmet Ozkan made a Powerpoint presentation on “deck elements”, including plinth attachments, existing bridge rail modifications, and OCS support concepts and loads. The following issues were discussed:

- Relocation of the existing median barrier will be required to add an HOV lane to the WB GP lanes.
- The plinth block spacing will generally be 2'-6" o.c. with roadway deck attachment flexibility. The IRT suggested that the plinth block spacing be modified to be compatible with the spacing of the existing transverse roadway deck post-tensioning (1'-9" spacing) – ST will consider recommendation.
- Only two anchors are required per plinth block for adequate anchorage to the existing deck. WSDOT has concerns about a number of plinth block anchors in a row, creating a potential “weaker pontoon section”.
- The IRT suggests that ST do a deck survey using “radar” technology to map the location of reinforcing steel and transverse deck post-tensioning.
- Roger Koester showed conceptual details of a lightweight rail between the LRT tracks and the 10' maintenance access provided for WSDOT HH Floating Bridge maintenance staff. There were some questions raised that this 10' wide access may be less useful than the maintenance access currently available on the bridge.

The Following Action Items Were Identified

- The IRT will meet with Ed Wetzel on 4/23/08 afternoon to view and discuss the continuity tests being performed by ST on the HH Floating Bridge.
- ST look at the very worst possible stray current scenario and resulting reinforcing corrosion with the two following conditions:
  - Long term section loss
  - Short term breakdown of insulation (not detected for 1 year)

The IRT will provide ST with suggested guidelines in determining spalling and reinforcing steel section loss resulting from stray current. WSDOT will provide a “section capacity” for the HH Floating Bridge roadway deck pontoon section. ST will then be able to determine the loss of pontoon load capacity for each condition. This analysis will be used for a baseline to discuss stray current mitigation options.

- ST and WSDOT will meet to discuss and agree on an appropriate earthquake design criteria for the transition spans and approaches for the HH Floating Bridge.
- ST and WSDOT will initiate discussions on maintenance and operation of the HH Floating Bridge (and approaches) in combination with the addition of LRT.
- Meeting notes will be distributed by the IRT by April 30 to Theresa Greco, Don Billen, and David Forte. They will distribute the meeting notes as they deem appropriate.
- ST will come up with deflection, curvature criteria for the rail bridge/expansion joint conceptual design. This criteria will take into consideration rider comfort issues.

Rick Johnson of KPFF came to the meeting at about 3PM to discuss the studies performed by KPFF on the HH Floating Bridge. The following information was provided:

- KPFF performed 5 studies on WSDOT floating bridges over the last 10 years or so. In addition, KPFF did the design for the strengthening of the SR 520 Floating Bridge.
- KPFF did not study the approach span earthquake vulnerability to a 1000-year earthquake. If this is the standard for LRT, he suggests that the analysis be performed.
- KPFFs analysis indicates that the transition spans need cover plate retrofits to meet the deflection criteria for LRT.
- KPFF suggests that the pontoon bending & torsion capacity be determined for future analysis of load combinations.
- KPFF did study the possibility of placing a monorail system on the HH Floating Bridge. For weight mitigation, 1” of existing overlay had to be removed and replaced with ¼” of polymer overlay.

ST and WSDOT stakeholders left, followed by a short IRT discussion. The IRT developed a list of LRT “issues” to be discussed the following day.

The meeting was adjourned at 5PM

Wednesday, April 23

Attendees: IRT  
Theresa Greco – WSDOT  
David Forte – JTC  
Don Billen – ST

The list of issues identified at the previous day's meeting were discussed. The IRT decided that several major decisions and criteria were needed for the IRT to meet the milestones established in the contract scope of work. A letter was drafted by the IRT outlining these needs. Tom Ballard will have Chuck Ruth review the draft letter, provide comments, finalize the letter, then send a pdf copy of the signed letter by the end of the day on April 24, followed by a hard copy sent to Theresa. During the drafting of the letter, Theresa, David, and Don were encouraged to provide comments. A copy of the draft letter was given to Theresa, David, and Don.

In addition, the IRT identified additional issues that would eventually have to be addressed by ST and/or WSDOT for successful installation of LRT on the HH Floating Bridge. Each issue would be assigned to an LRT member for scoping and determination of need. Following is the agreed action plan and a summary of the issues along with the assigned LRT member:

*IRT Action Plan*

Meeting Minutes to IRT members by April 25, 2008

Meeting Minutes comments by IRT to Chuck by April 29, 2008

Meeting Minutes issued by May 1, 2008

The following action plan was prepared IRT Team on April 23, 2008. IRT member assignments were made and members are to respond with plan by the 12<sup>th</sup> of May, 2008 and issued by Tom Ballard the 13<sup>th</sup> of May, 2008.

Each action item will be comprised of the following:

*Issue (brief sentence that frames the issue – see list below)*

*General Description and Background (What specific information we require, why we need the information and what it will be used for)*

*IRT Member Assigned to Issue*

*Responsible Agency*

*Data Sources (What document was provided and who provided it to satisfy this information request)*

*Resolution of Issue and Recommended Completion Date*

*Draft issue list with IRT member assigned responsibility:*

1. Rail Bridge/Expansion Joint Design/Performance (Criteria For Design) – Chuck
2. LRT Operational Restrictions for combination of train loading and 1 year storm loading (From North) Tom Bringloe
3. *Seismic design/retrofit of approach spans (1000 year event?) - Tom Ballard*
4. *LRT/Tunnel Safety/Ventilation Requirements (not part of IRT scope, but needs to be addressed by ST) – Tom Ballard*
5. Need for Lightning Arrestors on Floating Bridge and Approaches - Steve
6. ST Following Their Own Stray Current Mitigation Criteria For HH Bridge Installation – Steve
7. Impact Of Stray Current Dispersion in Lake Washington On Environment/Fish - Chuck
8. Stray Current/Cathodic Protection System Interference/Compatibility - Ali
9. Upgrading Existing HH Bridge Cathodic Protection System (needed regardless of LRT decision) - Ali
10. Need Analysis To Confirm Torsional Capacity of the Existing Bridge (97%) – Tom Bringloe
11. Need Analysis "North Wind" Storm Effects On HH Bridge (Glosten Can Perform Analysis) - Tom Bringloe
12. *Criteria Needs To Be Established for IRT to evaluate numerous issues (stray current, seismic design level, deck penetrations, etc.) – Tom Ballard*
13. Operation/Maintenance Coordination/Agreement Between ST & WSDOT (access, frequency, responsibilities, staffing, timing, impact to operation of LRT) - Chuck
14. *Rider Comfort Criteria For LRT Bridge/Expansion Joint Rail – Tom Ballard*
15. Attachment of OCS Supports To Edge of HH Bridge Cantilevers (minimize impacts to existing PT/reinf) - Chuck

16. Method Utilized For Locating Rebar & PT in Bridge Deck (To Minimize Damage For Plinth attachment Installation) - Ali
17. Prototype Testing of Rail Bridge (At Expansion Joint) - Timing and Criteria For Testing – Chuck
18. Determining Strength and Resistance Of Existing Concrete - Ali
19. Modification of current bridge inspection procedures if LRT approved (frequency, type, etc) - Steve
20. Storm water Drainage System modifications under new LRT rail bridge - Chuck
21. Median Barrier Relocation Design/Attachment/Maintenance/Drainage Issues - Chuck
22. Determination of Cost Associated with a) HH Bridge Replacement b) Construction Impact/Bridge Shutdown - Chuck
23. *What is WSDOT/ST Goal for Life Expectancy of HH Bridge – Tom Ballard*
24. Method For Identifying Stray Current Failure and Response/Repair Plan - Steve
25. Effect of LRT Installation on Construction Operations Associated With Anchor Cable Replacement – Tom Bringloe
26. What Additional Needs/Changes Are Required For LRT Installation To meet "Blue Ribbon Panel" recommendations? – Tom Bringloe

The meeting was adjourned at 3PM

Documentation Provided to the IRT during the three days of meetings are as follows:

1. ST Vehicle Ride Quality Technical Specification
2. Bridge Rectifier Description
3. Aerial Structures Deflection and Vibration Design Criteria
4. Noise and Vibration Design Criteria
5. East Link Project Brochure
6. Approach Span Erection Plans & Conduit Layout
7. I-90 Independent Review Log of Reports and Drawings
8. Sound Transit April 22, 2008 Presentation to IRT
9. April 22, 2008 Attendee Sign Up Sheet
10. I-90 Corridor Tour of April 21, 2008
11. HH Floating Bridge Construction Material Specifications
12. INCA Engineers OCS Pole Attachment Calculations

**Independent Review of LRT Feasibility  
On The Interstate 90 – Homer Hadley Floating Bridge  
IRT Meeting and JTC Briefing of May 22, 2008**

**1. IRT Meeting**

Independent Review Team (IRT)

Tom Ballard (SC Solutions) – Team Leader  
Tom Bringloe (The Glostten Associates)  
Steve Nikolakakos (Russell Corrosion Consultants, Inc.)  
Chuck Ruth (SC Solutions)  
Ali Akbar Sohahnpurwala (CONCORR, Inc.)

WSDOT Contact – Theresa Greco

ST Contact – Don Billen

JTC Contact – David Forte

Pre-JTC Briefing Meeting with ST and WSDOT (8:30AM to 2PM, and 3:30PM to 4:30PM)

Attendees: IRT (Ali and Steve by conference call)  
David Forte – Joint Transportation Committee (JTC)  
Theresa Greco – WSDOT  
Don Billen – Sound Transit  
Roger Koester – Parsons (Sound Transit)  
Sue Comis – Sound Transit  
Isam Awad – Sound Transit  
Walter Eggers – Parsons (Sound Transit)  
Dave Stensby – INCA (Sound Transit)  
Dan Russell – INCA (Sound Transit)  
Steve Kambol – CH2M HILL (Sound Transit)  
Ahmet Ozkan – INCA (Sound Transit)  
Patrick Clarke – WSDOT  
Ed Wetzel – PCS (Sound Transit – by conference call)

As an introduction, Tom Ballard indicated that the IRT presentation to the JTC would consist of explaining the list of the LRT issues would not include a discussion of the content of the DRAFT Issue Resolution Report. Tom indicated that the DRAFT Issue Resolution Report would be discussed at this pre-JTC meeting, allowing time for ST and WSDOT to provide comments before the Issue Resolution Report is finalized next week. At this meeting, the issues will be discussed one by one. The “track bridge” issue (#1) importance classification has been raised to “high” at the request of Chuck Ruth due to the need for advanced engineering and testing, and the uniqueness of this facility.

### **Issue #6 – Stray Current Mitigation Criteria**

Ed, Steve, and Ali met together on the East Coast and then phoned into Seattle to report on their discussion. They discussed stray current mitigation criteria. Ed indicated that electrical continuity testing on the Homer Hadley bridge established that ST criteria for continuity is met. However, both Steve and Ali discussed this with Ed and reached agreement that electrical continuity can only be established for the pontoon wall reinforcing. Electrical continuity for the roadway pontoon slab deck reinforcing cannot be established, primarily because the top mat of reinforcing steel is epoxy coated. Ali/Steve feel that the stray current mitigation should be a “fail safe” system. Ed’s proposal was that the existing bottom layer of reinforcement in the top deck of the pontoons be used to monitor stray current. Ed indicates that the stray current collected in the bottom mat of top deck reinforcing will be discharged at a low level from the pontoons into Lake Washington. A stray current monitoring system is critical to detection of potential fastener failure or some other related problem. The goal would be that once a stray current leak (fastener failure) is detected, repairs would be made within 1 week. The IRT suggests that a stray current “collection mat” be part of the mitigation for stray current. ST’s concerns were that embedding such a mat would require additional concrete on the bridge deck and would be a weight mitigation issue. Steve, Ali, and Ed discussed the issue further and arrived at a solution that will place the collector mat in the plinth blocks.

### **Issue #7 – Impact of Stray Current on Fish**

Sound Transit indicates that Ed and a “fish biologist” will meet to discuss. This issue needs more study to determine the nature and level of possible impact. The importance classification has been changed from high to low in the Draft Issue Resolution Report.

### **Issue #8 – Stray Current & Cathodic Protection System, and Item #9 – Upgrading Existing Cathodic Protection System**

Theresa indicates that the cathodic protection issue was discussed with Dave Dye and that the issue is being elevated to the Secretary of Transportation. The IRT believes that the existing cathodic corrosion protection system, although not up to current standards and performance, is providing some level of protection to the anchor cables. WSDOT would like input from the IRT on a recommended improvement to the existing cathodic protection system. Also, would a new and improved cathodic protection system be cost effective (would cost and maintenance offset cost of more frequent anchor cable replacements)? The IRT believes that the current cathodic protection system for both the HH Bridge and the LVM Bridge need to be upgraded. The existing cathodic protection systems are not set up to be monitored remotely. This makes monitoring and maintenance more time consuming and costly. Newer cathodic protection systems can be set up to monitor remotely and are more reliable. Patrick indicated that he would like the current in the anchor cables to be monitored as well. Ali indicated that this could be set up as part of the cathodic protection



system upgrade. The stray current collector mat should be kept separate or decoupled from the cathodic protection system.

**Issue #10 – Confirm Torsional Capacity, Issue #2 – Operational Restrictions, and #11 “North Wind” Storm**

Don Billen wanted to know if the IRT was performing an analysis on this issue. Tom Ballard indicates that an analysis is being performed for IRT’s information only. Since current analysis by others indicates that the combination of LRT and wind/wave loading stresses the pontoon section up to 97% of capacity, the IRT is doing their own analysis to determine the sensitivity of the stress level to the loads and load combinations. Patrick Clarke indicates that the field load testing was done to determine if the actual load distribution/deflection was comparable to the computer analysis. The modulus of elasticity (E) was adjusted (in the computer model) to be consistent with the deflections and stress levels actually measured during the load test. Ahmet’s analysis indicates that the pontoon section has a higher capacity than that used by WSDOT to establish the “97% of capacity” value. The probability of occurrence of the LRT live load used for this analysis is remote. Tom Bringloe is looking at the wind/wave loading from the North. Tom indicates that a 1-year storm from the North is much less severe than a 1-year storm from the South. The estimate is that a 1-year storm from the North causes about ½ the stress level as a 1-year storm from the South. Since the existing LVM Bridge protects the HH Bridge from South storms, the 1-year North storm should be used for this “operational level” analysis. It is likely that the final analysis will indicate that a less frequent (higher level) storm from the North will be the basis for establishing an operational “storm limit” for shutting down the bridge to LRT traffic (and possibly vehicular traffic).

**Issue #12 – Design Criteria**

Don Billen indicates that Sound Transit will respond to the IRT on this issue by May 30. The IRT is primarily looking for design criteria consistency for all elements (I-90 Link Criteria should be comparable to Criteria on other LRT facilities).

**Issue #14 – Rider Comfort Performance**

Don Billen indicates that Sound Transit has prepared a technical memo on this issue that they will provide to the IRT.

**Issue #15 – OCS Attachments**

Note: This issue was discussed after the JTC briefing. Sound Transit provided a paper that discussed the support pole attachment and provided concept construction details. The details were developed with the intent of minimizing any drilling into the existing bridge. The IRT is very concerned about any attachment to the pontoon cantilever that requires drilling into the existing bridge. The post-tensioning in the deck is critical to the structural adequacy and performance of the cantilever. Any damage resulting from anchoring into the

deck could have severe structural impacts with few or no options for repair. The IRT suggests:

- That Sound Transit consider keeping a portion of the existing traffic barrier to support fall protection rail posts rather than removing the entire rail and drilling into the deck for rail post supports.
- That Sound Transit consider using light weight concrete for any concrete support elements added to the bridge.
- That Sound Transit develop an OCS support post design that attaches to and utilizes a portion of the existing rail in combination with a “clamping support” or similar attachment that does not require drilling into the cantilever.

Ahmet indicates that alternate attachment methods need to be considered within the “weight mitigation” requirements. Patrick indicates that over the years WSDOT’s experience has been that floating bridges seem to lose freeboard, so it is important to achieve the “no loss of freeboard” as part of the design process.

#### **Issue #16 – Plinth Block Attachment/Method for Locating Steel Reinforcing**

Note: This issue was discussed after the JTC briefing. Sound Transit provided a paper that discussed plinth blocks and provided proposed attachment construction details. There will be a deck reinforcing locating device tested next week on May 28 (on a concrete test panel) and May 29 (on the HH Floating Bridge). Chuck Ruth from the IRT will be available to observe the testing on May 29. Don Billen will contact Chuck Ruth regarding timing of the field test. There was discussion on attachment of the plinth blocks to the pontoon deck. IRT again expressed the concern about potential damage to the existing reinforcing and post-tensioning in the deck. Sound Transit indicates that their analysis shows that drilled attachments into the pontoon deck are not necessarily required, but that none of their engineers are comfortable with using only an adhesive type of plinth block attachment. The IRT suggests that Sound Transit consider the following:

- Use only one drilled in anchor per plinth block into the pontoon deck instead of two.
- Prior to final design, construct a concrete pad under a traveled LRT rail section or test section similar in strength a thickness, and reinforcing characteristics to the HH Floating Bridge deck. Then use this concrete slab test section to test a number of plinth block attachment concepts, including the concept they have proposed. Concepts that are tested should include “adhesive only” attachment.

#### **Issue #18 – Strength of Existing Concrete Strength/Stray Current Resistance**

There is a question of the actual strength of the existing concrete and the resistance to passage of stray current. Patrick Clarke estimates the concrete strength to be in the neighborhood of 12,000psi as an average. Cores can be

taken (if necessary) to help determine the properties of the existing concrete. Patrick suggests that the cores be taken at intermediate interior transverse bulkhead walls and that the selected locator method be used for locating the core location(s). 3" diameter cores were agreed to be the best choice for sampling. Ali will provide Sound Transit with more information on cores. It was agreed to take two cores near each location sampled (one to test strength and one to test resistance).

### **Issue #21 – Median Barrier Relocation**

There was some discussion about the impact of median barrier relocation on potential damage to the existing pontoon roadway deck and maintenance access. Sound Transit and WSDOT are looking more into this issue and will report back to the IRT.

### **Issue # 1 – Track Bridge/Expansion Joint Prototype Testing**

Sound Transit agrees that this needs to be done. The only question is cost and timing of the testing. Assuming prototype testing is performed, it will likely result in production track bridges being fabricated, tested, and approved prior to contract and provided to the LRT contractor as agency-provided materials for final construction. Patrick is concerned about the weight of the track bridge and the structural modifications required to support the track bridge. Sound Transit's track bridge analysis indicates that the internal member stresses are OK and that prototype testing will test fatigue of those elements and the working parts (and attachments). The IRT will probably request a plan from Sound Transit that addresses rail bridge final design, prototype testing, production rail bridge fabrication, and the time schedule for all.

### **Issue #3 – Seismic Vulnerability & Retrofit of Approach/Transition Spans**

(based on 1000-year, no collapse criteria)

Sound Transit and the IRT are performing analysis on this issue and should have information for further discussion within a few weeks. The IRT will be recommending that the Mount Baker Ridge Tunnel be evaluated with the same seismic vulnerability criteria as being used for the HH Floating Bridge approaches and transition span. Patrick Clarke indicates that for seismic design, WSDOT uses a 2500-year return period earthquake for major investment bridges only (example: Tacoma Narrows Bridge on SR 16).

### **Issue #5 – Lightning Arrestors**

Sound Transit indicates that they are developing criteria and concepts to address this issue.

### **Issue #13 – Operation and Maintenance Agreement**

(Between Sound Transit and WSDOT)

The IRT indicates that they would like to see a plan and schedule from Sound Transit that addresses this issue.

**Issue #22 – Economic Impact**

The IRT suggests that WSDOT/Sound Transit develop a cost associated with loss of this facility (there will be LRT impacts, vehicular traffic impacts, and replacement/repair construction cost impacts associated with loss of this facility). The IRT suggests that this information would be valuable information for evaluating “risk” and executive/legislative decisions.

**Issue #24 – Method for Identifying Stray Current Failure**

Steve and Ali believe that the addition of a stray current “collector mat” addresses IRT concerns about stray current. The collector mat will also make identification and location of rail fastener failures easier to detect and locate.

**Issue #14 – Rider Comfort Performance**

Sound Transit looked at vehicle accelerations. Tom Ballard indicates that the uniform distribution assumed by Sound Transit in their analysis may be unconservative. With the assumptions used by Sound Transit, the accelerations looked good and within acceptable limits at a 45MPH speed (0.035g acceleration). Sound Transit does not have an accurate idea of actual movements, but will develop a better and more accurate analysis as design proceeds. Sound Transit believes that their analysis is conservative because it accounts for only a portion of the dampening effect of the light rail vehicle. Tom Ballard indicates that the IRT has done some preliminary analysis that indicates the issue is not a “show stopper”, but may limit operational speed (to maybe 25 to 30 MPH) when the bridge is experiencing an extreme event or when anchor cables are being replaced on the cross pontoons. Sound Transit intends to instrument the HH Bridge to monitor operational movements. IRT supports this proposal and suggests that this instrumentation be installed ASAP to collect data.

**Note: Issues #19 (Bridge Inspection Procedures), #20 Stormwater Drainage, #25 Effect on Anchor Cable Replacements, and #26 Blue Ribbon Panel were not discussed due to the lower priority of these issues and the limited time available.**

Documentation Provided to the IRT during the meeting are as follows:

13. Sound Transit East Link Project – OCS Pole/Deck Attachment Analysis dated 5/16/2008
14. Sound Transit East Link Project – Plinth Block Analysis dated 5/20/2008
15. Sound Transit East Link Project – Rider Comfort Performance for LRT Track Bridge at Expansion Joints dated 5/21/08
16. Data Sheet For Stray Current Calculations, Sound Transit I-90 Bridge Feasibility, dated May 20, 2008.

## **2. JTC Meeting, 2PM to 3:30PM**

Attendees:

Representative Judy Clibborne  
Senator Mary Margaret Haugen (by conference call)  
Legislative Staff:  
Beth Redfield, House Transportation  
Haley Gamble, Senate Transportation  
David Forte – JTC  
WSDOT:  
Dave Dye  
Ron Paananen  
Theresa Greco  
Patrick Clarke  
David Hopkins  
Sound Transit:  
Don Billen  
Roger Koester  
IRT (Ali and Steve by Conference Call)

Tom Ballard introduced the IRT and explained that the study was going well. He indicated that the cooperation, discussion, and exchange of information between the IRT, Sound Transit, and WSDOT was very good. Tom briefly discussed the IRT progress and the determination of desirable remaining bridge life as determined by WSDOT and Sound Transit.

Following the introduction, each issue identified by the IRT (26 total issues) was explained to the JTC briefing attendees. The attendees asked some clarifying questions as the issues were explained. Each issue was explained by the IRT member assigned to the particular issue. Tom Ballard then outlined the upcoming IRT Study milestones and completion dates as follows:

- Final Issues Report – By End of May
- Preliminary Findings to JTC – June 18
- Final IRT Report - September

At the end Rep. Clibborne indicated that she was please with the direction and progress of the IRT.

# **LRT Feasibility Study – Homer Hadley Floating Bridge and Approach Spans IRT/Sound Transit/WSDOT/JTC Meeting**

## Agenda

August 11, 2008

Attendees: IRT  
Alex Krimotat, SC Solutions  
Hassan Sadarat, SC Solutions  
Dan Russell, INCA  
Isam Awad, Sound Transit  
Roger Koester, Parsons  
Ed Wetzel, UTRS  
Ahmet Ozuan, INCA  
Sue Comis, Sound Transit  
Don Billen, Sound Transit  
Steve Gleaton, Sound Transit  
David Forte, JTC  
Theresa Greco, WSDOT

Chuck Ruth explained the status of the report. The final draft report will be posted on an SC Solutions FTP site by August 19 in PDF format. It was noted that comments can be made to a document in this format. Comments (if any) will need to be returned by August 26 or 27. After some discussion, it was decided that the final report will be submitted to JTC/WSDOT in hard copy and electronic format. Any calculations will be submitted to JTC/WSDOT as hard copies. All tech memos and calculations will include a disclaimer basically stating that these documents are for preliminary design only and not intended to be a basis for final design.

There was some discussion about the presentations to the JTC (August 12), HTC (September 11), and possibly STC (September 5). Sound Transit/WSDOT will be making a presentation to the JTC (August 12) immediately following the IRT presentation. The IRT presentation will primarily focus on three subject areas; stray current, track bridge prototype testing, and approach span seismic vulnerability.

Stray Current Mitigation: There was considerable discussion about stray current and associated issues. The IRT's (Steve & Ali) concern was that the Cathodic Protection System be utilized only as a backup and not as an element of the Sound Transit stray current collection system. Sound Transit agreed to this stray current collection system design philosophy.

Track Bridge Prototype Testing: Sound Transit indicated that they were committed to early design and prototype testing of the track bridge. SC Solution

representative Hassan Sedarat made a slide presentation that outlined the analysis performed on the track bridge and results of that analysis. For maximum joint movements in combination with LRT live load, the track bridge member stress approached 61 KSI, which would be close to the elastic limit of the material. Tom Bringloe indicates that the joint movements associated with this load case could only occur if there were a major anchor failure and resulting movement of the bridge, and therefore LRT live load would not likely occur at the same time.

Seismic Vulnerability Study – Approach Spans: A slide presentation was made by Hassan Sedarat summarizing the analysis performed by SC Solutions and associated results. SC Solutions analysis indicates a number of approach span pier elements that had Capacity/Demand ratios that exceed 1 (1 or less is the desirable limit). It was recognized that all seismic vulnerability analysis performed by the IRT and Sound Transit is preliminary, and is based on a number of simplifying assumptions. It was agreed that a more detailed and complete Seismic Vulnerability Study needs to be completed early in the design process to determine a retrofit strategy and associated cost. It was also noted that approach span seismic retrofit costs could create a significant impact on the overall cost of the East Link project. It is the IRT's position that the West "Westbound" Approach Span should be retrofitted to meet the 1000-year seismic event criteria, since it would extend over the top of the LRT approach structure where they both enter the East portal of the Mount Baker Ridge tunnel on Interstate 90. Sound Transit indicated that they expected WSDOT to take the lead in the approach span seismic vulnerability analysis.

Action Items:

- Completion of the Draft Final Report by August 19
- Sound Transit commitment to utilize cathodic protection as backup only
- Seismic Vulnerability Study/Retrofit Strategy analysis to be the responsibility of WSDOT

# I-90 HOMER HADLEY FLOATING BRIDGE

## Independent Review Team - Light Rail Train Impacts



## ***APPENDIX D: REFERENCE***

---

**SC SOLUTIONS** In Association with

 **THE GLOSTEN ASSOCIATES**  
Consulting Engineers Serving the Marine Community

 **RUSSELL CORROSION CONSULTANTS, INC.**  
Columbia, Maryland  
Garden City, New York

 **CONCORR, Inc.**  
CONCRETE CORROSION SPECIALISTS



## **Appendix D – References**

### **Calculations:**

1. Washington State DOT, Log of Test Boring, 3<sup>rd</sup> Lake Washington Floating Bridge, February through April, 1983.
2. INCA Engineers Inc., OCS Pole Attachment Calculations, ST HCT Post-Conceptual, Job Number 06-035A, May 2008
3. Parsons, OCS Pole Attachment Calculations, Computation of Axial, Shear and Moment Loads at Pole Bases for Two-Track Portal, Seattle Sound Transit, April 2008.
4. Parsons, OCS Pole Attachment Calculations, Computation of Axial, Shear and Moment Loads at Pole Bases for Two-Track Cantilever, Seattle Sound Transit, April 2008.
5. Washington State DOT, Homer M. Hadley Bridge, Ultimate Section Capacities for Flooding Analysis and subdivision Recommendations, August 1994.
6. Washington State DOT, 3<sup>rd</sup> Lake Washington Floating Bridge Stage II, Roadway Pontoon Design Calculation and STRUDL Output Typical Section and Final Condition, March 1983.
7. INCA Engineers, Inc., ST HCT Post-Conceptual, Plinth Block Attachment Calculations, May 2008.

### **Design Criteria:**

8. Sound Transit, Link Light Rail – North Link and Airport Link Design Criteria Manual, Revision 0, Reprint November 2005.

### **Reports:**

9. Kinkisharyo International, L.L.C., Sound Transit - Car Body Roll Control Method ER2013, March 2005.
10. E-Mail Communication from Parsons to Sound Transit, Lightening Protection, April 29, 2008.
11. Shannon & Wilson, Inc., Summary Geotechnical Report, Interstate 90, Mt. Baker Ridge Tunnel Bore, Seattle, Washington, November 1981.
12. The Glostén Associates, Inc., Wave Loading Analysis of Lake Washington Bridges Volume 1, June 1983.
13. The Glostén Associates, Inc., Wave Loading Analysis of Lake Washington Bridges Volume 2, Analysis and Results, New 9-90 Floating Bridge, May 1983.
14. Municipality of Metropolitan Seattle, I-90 Light Rail Conversion Feasibility Study, May 1984.
15. Report of the Governor's Blue Ribbon Panel, Investigation into the Sinking of the I-90 Lacey V. Murrow Bridge, May 2, 1991.
16. Parsons Brinckerhoff / Kaiser Engineers Team Technical Memo, Use of I-90 Floating Bridge for Rail Transit, November 11, 1991.
17. Intermountain Corrosion Service, Inc., Cathodic Protection Assessment, I-90 Bridges, Lacey V. Murrow & 3<sup>rd</sup> LW Bridge, October 1993.
18. KPFF Consulting Engineers, Evergreen Point Floating Bridge Seismic Evaluation, June 1993.
19. Norton Corrosion Engineers, Cathodic Protection Systems, Third Lake Washington Bridge, July 1993.

20. The Glosten Associates, Inc., Homer M Hadley Floating Bridge, Flooding Analysis and Subdivision Recommendations, December 1994.
21. KPFF Consulting Engineers, Homer Hadley (Interstate 90) Floating Bridge, Draft Structural Feasibility Study, Light Rail Conversion, September 13, 2001.
22. KPFF Consulting Engineers, Homer Hadley (Interstate 90) Floating Bridge, Approach Structure and Transition Span, Draft Structural Analysis Study, Light Rail Conversion, August 31, 2001.
23. Hardesty & Hanover, LLP and CONCORR, Inc., In-Depth Cathodic Protection System Inspection and Recommendations, Lacey V. Murrow Bridge, Homer Hadley Bridge, May 2004.
24. KPFF Consulting Engineers, Homer Hadley (Interstate 90) Floating Bridge, Draft Structural Feasibility Study, Monorail Conversion, February 2005.
25. KPFF Consulting Engineers, Third Lake Washington Bridge, Design Criteria – Floating Structure – Stage II pontoons, October 2005.
26. Collins Engineers, Inc., Underwater Inspection Report for the Homer Hadley Floating Bridge, Volume 1 and 2, September 2006.
27. Conference Call Documentation, Expert Review Panel Members, Regarding Use of the I-90 Bridge for Light Rail Operations, June 7, 2006.
28. Geophysical Survey Systems, Inc., GSSI Handbook for RADAR Inspection of Concrete, August 2006.
29. Geophysical Survey Systems, Inc., StructureScan Standard, November 2007.
30. Hardesty & Hanover, LLP and CONCORR, Inc., In-Depth Cathodic Protection System Inspection and Recommendations, Lacey V. Murrow Bridge, Homer Hadley Bridge, May 2006.
31. KPFF Consulting Engineers, Homer Hadley (Interstate 90) Floating Bridge, Test Program for Light Rail Transit, January 20, 2006.
32. Parsons Brinckerhoff Quade & Douglas, Inc., East Corridor HCT – Summary of I-90 Floating Bridge (Homer Hadley) Studies, March 2006.
33. Daniel G. Stromberg, Underwater Inspection Report Floating Bridges, 2006.
34. Washington State DOT, Homer Hadley Bridge Operations, Inspection and Preventative Maintenance Guidelines and Procedures, July 2006.
35. Expert Review Panel Meeting Summary, June 28 and 29, 2007.
36. The Glosten Associates, Dynamic Analysis of SR520 Replacement Floating Bridge Response to Wind and Wave Loads, Interim Report, Volume 1, May 30 2007.
37. INCA Engineers, Inc., Eastside HCT Corridor, SR90 Floating Bridge (Homer Hadley), Expansion Joint Study, Final Report, March 2007.
38. Jacobs Associates, Final Draft Summary Geotechnical Report for Preliminary Route Selection, September 6, 2007.
39. LTK Engineering Services, Sound Transit East Link Rail Transit Project Traction Power Simulation, Draft Report, November 2007.
40. Parsons, Sound Transit East Link Project, Overhead Catenary System Concept Study, Draft Report, September 2007.
41. Parsons, Sound Transit East Link Project, Phase 2, Overhead Catenary System Concept Study, Final Draft Report, December 2007.
42. Parsons, Sound Transit East Link Project, Stray Current Analysis Report, Draft Report, August 2007.
43. Parsons, Sound Transit East Link Project, Phase 2, Stray Current Analysis Report, Draft Report, December 2007.

44. Parsons, Sound Transit East Link Project, Phase 2, Ventilation Analysis of Existing I-90 Tunnels, Mount Baker and First Hill Tunnels, Final Draft Report, August, 2007.
45. Sound Transit, East Link Project, Eastside HCT Corridor, I-90 Floating Bridge Expansion Joint Final Draft Report, September 2007.
46. Washington State DOT, Homer Hadley Floating Bridge, 2007 Random Watertight Inspection, January 10, 2008.
47. INCA Engineers, Inc., Sound Transit East Link Project, Phase 2, I-90 Floating Bridge (Homer Hadley), Expansion Joint Final Conceptual Report, January 2008.
48. INCA Engineers, Inc., Sound Transit East Link Project – OCS Pole./Deck Attachment Analysis, Working Draft Technical Memorandum, May 16, 2008.
49. INCA Engineers, Inc., Sound Transit East Link Project – Plinth Block Analysis, Working Draft Technical Memorandum, May 20, 2008.
50. INCA Engineers, Inc., Sound Transit East Link Project – Rider Comfort Performance for LRT Track Bridge at Expansion Joint, Working Draft Technical Memorandum, May 21, 2008.
51. INCA Engineers, Inc., Sound Transit East Link Project, Phase 2, Existing I-90 Bridges, Seismic Vulnerability Study, Final Conceptual Report, January 2008.
52. INCA Engineers, Inc., Sound Transit East Link Project, Phase 2, Existing I-90 Bridges, Vibration Study, Final Conceptual Report, January 2008.
53. LTK Engineering Services, Rail Voltage Mercer Island TPSS, April 2008.
54. LTK Engineering Services, Rail Voltage Rainier Station, April 2008.
55. Professional Corrosion Services, LLC, Work Plan for Electrical Continuity Testing of the I-90 Pontoon Components and Between pontoons, April 11, 2008.
56. Professional Corrosion Services, LLC, Work Plan for Rail Fastener Resistance Testing using Standard and Supplemental Isolation Technologies, April 11, 2008.
57. PROCEQ, Profometer 5 Rebar Detection System, 2007.
58. Universal Technical Resource Services, Inc., Data Sheet for Stray Current Calculations, Sound Transit I-90 Bridge Feasibility, May 20, 2008.
59. Washington State DOT, Bridge Inspection Report, Homer M. Hadley, January 22, 2008.
60. UTRS, Sound Transit East Link Project – Stray Current Analysis, June 11, 2008, Revised August 14, 2008
61. Parsons, Sound Transit East Link Project – Drainage Details at Expansion Joints, June 12, 2008
62. Letter from Sound Transit in response to the Independent Review Team's April 24, 2008 letter, May 30th, 2008 with Technical Memo Attachments
63. Mayes Testing Engineers, Sound Transit East Link Non-Destructive Testing Demonstration/Evaluation – Mayes Testing Engineers Project Number S08040, June 10, 2008, Revised July 11, 2008.
64. Parsons, Sound Transit East Link Project – Issue Resolution Report – Support Data, June 13, 2008.
65. Herrera Environmental Consultants, Inc., Interstate 90/Homer Hadley Bridge, Light Rail Transit (LRT) Stray Current – Assessment of Potential Effects on Fish, June 13, 2008.
66. INCA Engineers, Inc., Sound Transit East Link Phase 2 Project – IRT ISSUE C – Seismic Vulnerability and Seismic Retrofit of Approach Spans and Transition Span, June 13, 2008.
67. INCA Engineers, Inc., Sound Transit East Link Phase 2 Project – IRT ISSUE N – Attachment of OCS Supports to Edge of Homer M. Hadley Floating Bridge Deck Cantilevers, June 13, 2008.

68. INCA Engineers, Inc., Sound Transit East Link Phase 2 Project – IRT ISSUE S – Median Barrier Relocation, Design, Attachment, Maintenance and Drainage, June 13, 2008.
69. Washington State DOT and Sound Transit Letter to IRT Establishing Bridge Life Expectancy, May 13, 2008.
70. Mayes Testing Engineers, Inc., Sound Transit East Link Project—IRT Issue – Homer Hadley Floating Bridge Core Drilled Concrete Specimens, July 7, 2008
71. Sound Transit East Link Project--Seismic Design and Retrofitting Criteria, May 28, 2008
72. Independent Review Team Resistivity, Unit Weight, and Absorption Test Results, August 14, 2008, by Concorr, Inc.

**Construction Specifications and Contractor Instructions:**

73. Washington State DOT, SR90 3<sup>rd</sup> Lake Washington Floating Bridge – pontoons, Phase II, Construction Specifications.
74. Washington State DOT, SR90 Homer M. Hadley Bridge – Anchor Cable Replacement, Instructions.

**Drawings:**

75. Washington State DOT, SR90 3<sup>rd</sup> Lake Washington Floating Bridge, As-Built Drawings, 1981
76. CH2M Hill, Link Light Rail Project, East Corridor, Segment A Conceptual Drawings, July 2007.
77. Hatch Mott MacDonald, Link Light Rail Project, South Corridor, MLK Transition Structure, March 2005.
78. CH2M Hill, East Link Project, Segment A Typical Sections, January 2008.



**I-90 HOMER HADLEY FLOATING BRIDGE**  
**Independent Review Team**  
**Light Rail Train Impacts – Final Report**

SEPTEMBER 2008



**SC SOLUTIONS** In Association with

 **THE GLOSTEN ASSOCIATES**  
*Consulting Engineers Serving the Marine Community*

 **RUSSELL CORROSION CONSULTANTS, INC.**  
Columbia, Maryland  
Garden City, New York

 **CONCORR, Inc.**  
CONCRETE CORROSION SPECIALISTS