

TYPICAL RAIL ELEMENT

NOTES

1. Type 10 post shall be 6 x 8 timber, OR either W6 x 9, or W6 x 8.5 steel. Type 11 post shall be 10 x 10 timber or W6 x 15. For additional details see **Standard Plan C-1b**.
2. Type 10 guardrail post spacing shall be 6' - 3" on center. Type 11 shall be a maximum of 3' - 1 1/2" on center.
3. Spacing may vary depending on application. See **Standard Specification Section 9-16.3(1)** for rail element requirements.

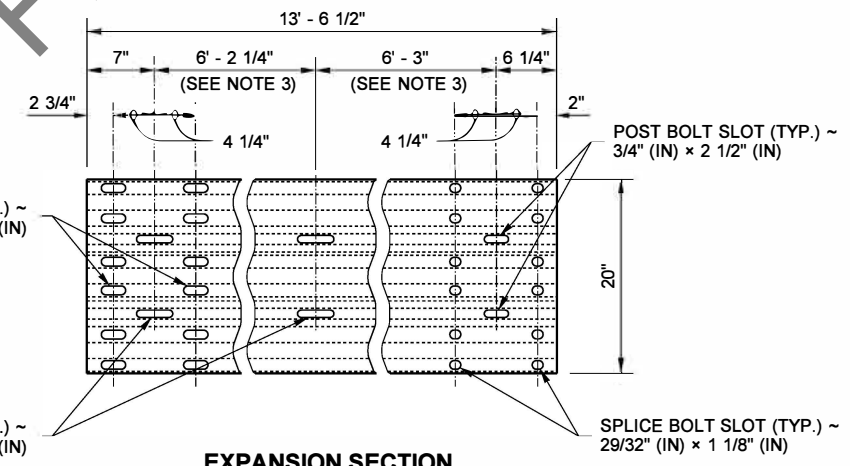

EXPANSION SECTION

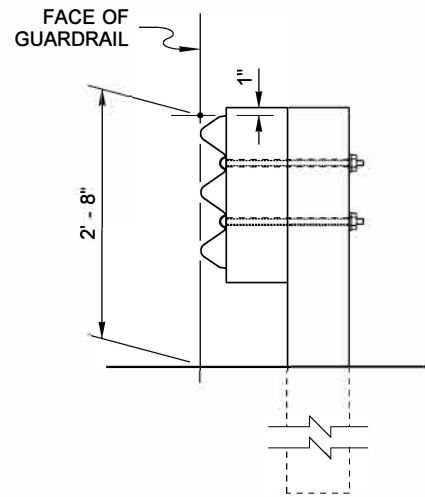

RAIL ASSEMBLY

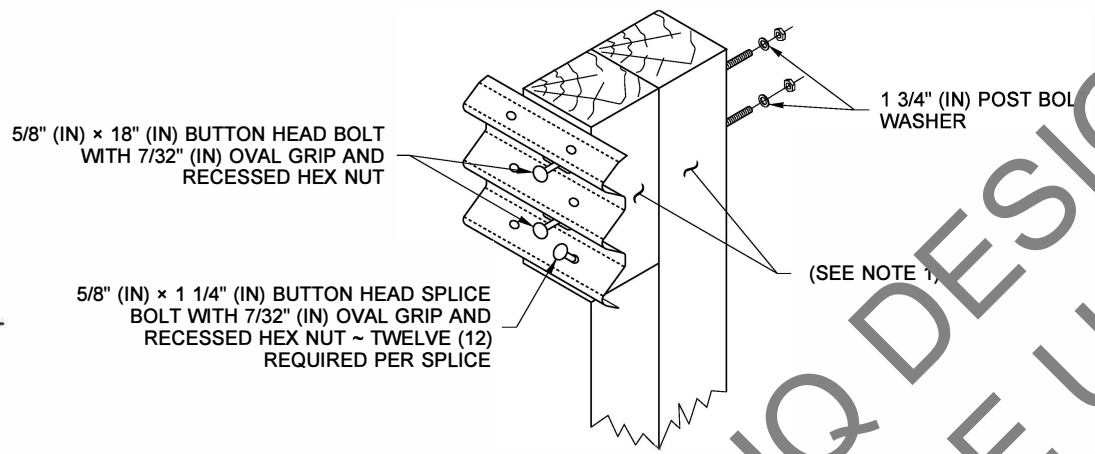

WOOD POST ASSEMBLY

TYPE 10

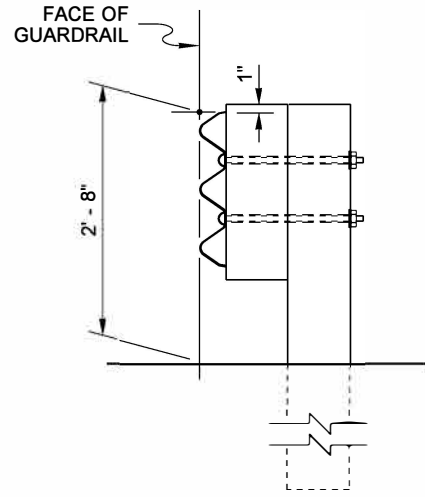

RAIL ASSEMBLY

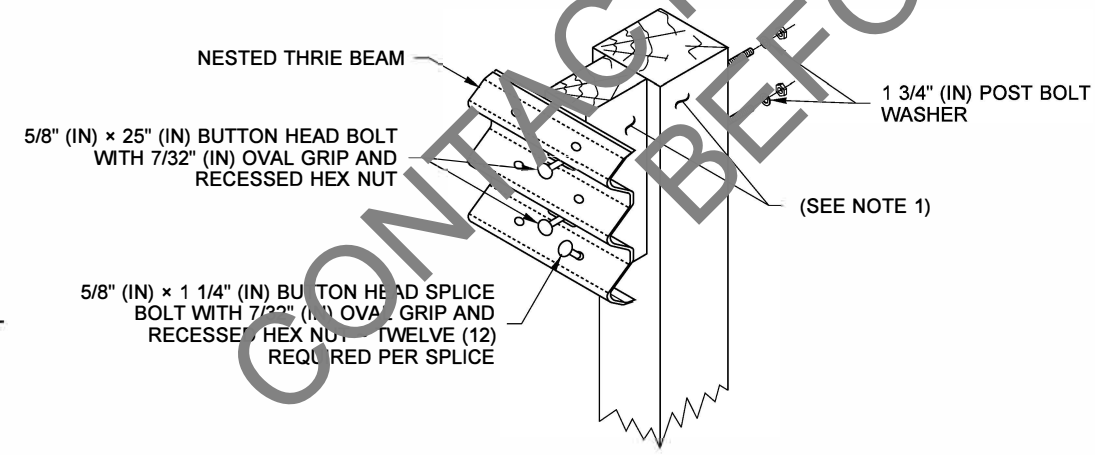

WOOD POST ASSEMBLY

TYPE 11

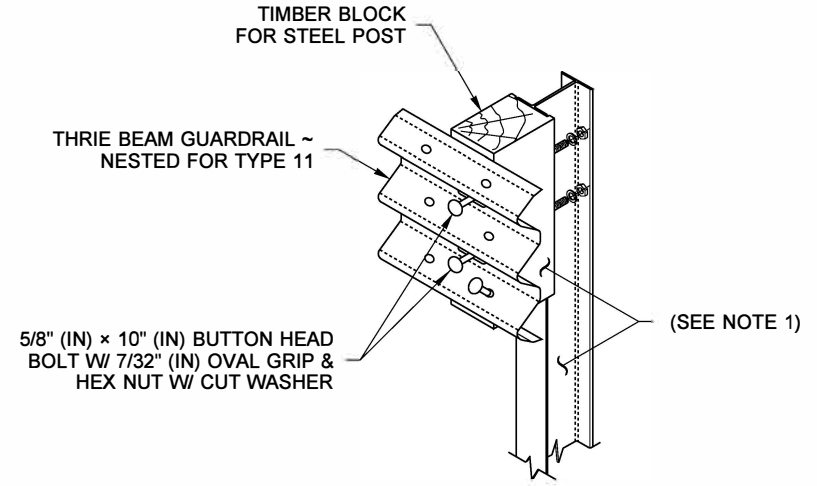

STEEL POST ASSEMBLY

TYPES 10 AND 11

FILE NAME	S:\Design R P & S\4-Standards\2-Plan Sheet Library\04-PSL Work in Progress\Std. Plan conversions to PSL 2020\TB- Barrier plans for conversion\TB-100_e.dgn			
TIME	10:50:42 AM			
DATE	8/19/2021			
PLOTTED BY	liddelf			
DESIGNED BY				
ENTERED BY				
CHECKED BY				
PROJ. ENGR.				
REGIONAL ADM.				
REVISION	DATE	BY	REGION NO.	STATE
			10	WASH
			JOB NUMBER	
			CONTRACT NO.	LOCATION NO.

FED.AID PROJ.NO.	DATE	P.E. STAMP BOX



PLAN REF NO
TB-100

**BEAM GUARDRAIL
(THRIE BEAM)**

SHEET
1
OF
1
SHEETS