



Transmittal Number 10-016	Date February 2010
Publication Distribution To: All <i>Washington State Bridge Inspection Manual</i> holders	
Publication Title <i>Washington State Bridge Inspection Manual</i> M 36-64.02	Publication Number M 36-64
Originating Organization Washington State Department of Transportation, WSDOT Bridge and TransAid through Engineering Publications	

Remarks:

The Washington State *Bridge Inspection Manual* has been revised. Page numbers and corresponding sheet-counts are given in the table below to indicate portions of the *Washington State Bridge Inspection Manual* that are to be removed and inserted to accomplish this revision.

Chapter	Remove	Insert
	Pages	Pages
Title Page	N/A	N/A
Contents	vii – x	vii – vii
Chapter 4, “Contents”	i – ii	i – ii
Chapter 4, “Bridge Management System”	4-1 – 4-76	4-1 – 4-76

Please e-mail us if you no longer desire to receive updates, have a quantity change, or your address has changed.

Washington State Department of Transportation
Finance and Administration
Administrative and Engineering Publications
PO BOX 47408
Olympia, WA 98504-7408

Phone: (360) 705-7430
Fax: (360) 705-6861
E-mail: enrpubs@wsdot.wa.gov

For questions regarding the content of this revision, contact Grant Griffin at (360) 705-7870 or e-mail GRIFFIN@wsdot.wa.gov

Distributed By Directional Documents and Engineering Publications	Phone Number (360) 705-7430 FAX: 705-6861	Signature /S/ Dave Mounts
----------------------------------------------------------------------	-------------------------------------------------	-------------------------------------



**Washington State
Department of Transportation**

TECHNICAL MANUAL

Washington State Bridge Inspection Manual

M 36-64.02

February 2010

Highways and Local Programs Division
Transportation Building
PO Box 47390
Olympia, WA 98504-7390
(360) 705-7370

Bridge Preservation Office
7345 Linderson Way SW
PO Box 47341
Olympia, WA 98504-7341
(360) 570-2555

Americans with Disabilities Act (ADA) Information

Materials can be provided in alternative formats: large print, Braille, cassette tape, or on computer disk for people with disabilities by calling the Office of Equal Opportunity (OEO) at 360-705-7097. Persons who are deaf or hard of hearing may contact OEO through the Washington Relay Service at 7-1-1.

Title VI Notice to Public

It is the Washington State Department of Transportation's (WSDOT) policy to assure that no person shall, on the grounds of race, color, national origin or sex, as provided by Title VI of the Civil Rights Act of 1964, be excluded from participation in, be denied the benefits of, or be otherwise discriminated against under any of its federally funded programs and activities. Any person who believes his/her Title VI protection has been violated, may file a complaint with WSDOT's Office of Equal Opportunity (OEO). For Title VI complaint forms and advice, please contact OEO's Title VI Coordinator at 360-705-7098 or 509-324-6018.

To get the latest information on WSDOT administrative and engineering manuals, sign up for e-mail updates for individual manuals at: www.wsdot.wa.gov/publications/manuals

Washington State Department of Transportation
Administrative and Engineering Publications
PO Box 47304
Olympia, WA 98504-7304

Phone: 360-705-7430
E-mail: engrpubs@wsdot.wa.gov
Internet: www.wsdot.wa.gov/publications/manuals

Appendix		
3.06-A	WSDOT Bridge Preservation Inspection Guidelines	3.06-A-1
3.06-B	UBIT Owners	3.06-B-1
3.06-C	Example Underwater Inspection Report	3.06-C-1
3.06-D	Example Fracture Critical Report & Procedures	3.06-D-1
3.07	WSDOT FORMS	3.07-1

Forms

Bridge Inspection Report
Inspection Report (Supplemental Form)
WSBIS Inventory Record
Inventory Report
Scour Field Evaluation
Underwater Inspection Report
Daily Site Dive Log
Fracture Critical Inspection Report
Prestressed Concrete Damage Report and Steel Damage Report
Fall Protection Plan
Emergency Action Plan
Lead Exposure Control Work Plan
Respirator Record
Confined Space Entry and Hot Work Permit

Chapter 4	Bridge Management System	4-1
4.0	Bridge Management System Introduction	4-1
4.1	Bridge Decks	4-5
4.2	Superstructure	4-11
4.3	Substructure	4-34
4.4	Culverts	4-46
4.5	Tunnels	4-48
4.6	Sidewalk and Supports	4-49
4.7	Bearings	4-51
4.8	Bridge Rail	4-54
4.9	Pedestrian Rail	4-55
4.10	Smart Flags	4-56
4.11	Seismic Restrainers	4-59
4.12	Expansion Joint BMS	4-61
4.13	Movable Bridges	4-70
4.14	Other Bridge Elements	4-70
4.15	Bridge Deck Overlays	4-73
4.16	Protective Coatings	4-73

Chapter 5	Bridge Analysis	5-1
5.01	General	5-1
5.02	Bridge Load Rating Revision Criteria	5-3
5.03	Scour Evaluation	5-5
	A. Determining Susceptibility to Scour	5-5
	B. Action Plans for Scour Critical Bridges	5-5
	C. Recording Bridge Scour Information	5-7
5.06	Bridge Sufficiency Rating	5-9
<hr/>		
Chapter 6	Special Reports — Damage and Repairs	6-1
6.01	General	6-1
6.02	Critical Damage - Bridge Repair Report	6-1
6.03	Routine Bridge Repairs	6-5
6.04	Maintenance - Bridge Repair Report	6-8
	Forms	
	Critical Damage - Bridge Repair Report	
	Maintenance - Bridge Repair Report	
	Local Agency – Sample Bridge Repair Form	
<hr/>		
Chapter 7	Short Span Bridges	7-1
7.01	General	7-1
7.02	Criteria	7-1
	A. Short Span Bridges Inspected	7-2
	B. Short Span Bridges Not Inspected	7-2
7.03	Inspections	7-2
7.04	Bridge Files	7-3
7.05	Reporting	7-3
	Appendix	
	7-A Bridge with Fill on Deck	7-A-1
	7-B Bridge with No Fill on Deck	7-B-1
	7-C Culvert with Fill on Deck	7-C-1

4.0	Bridge Management System Introduction	4-1
4.1	Bridge Decks	4-5
4.2	Superstructure	4-11
4.3	Substructure	4-34
4.4	Culverts	4-46
4.5	Tunnels	4-48
4.6	Sidewalk and Supports	4-49
4.7	Bearings	4-51
4.8	Bridge Rail	4-54
4.9	Pedestrian Rail	4-55
4.10	Smart Flags	4-56
4.11	Seismic Restrainers	4-59
4.12	Expansion Joint BMS	4-61
4.13	Movable Bridges	4-70
4.14	Other Bridge Elements	4-70
4.15	Bridge Deck Overlays	4-73
4.16	Protective Coatings	4-73

Contents

4.0 Bridge Management System Introduction

This chapter provides an overview of the Bridge Management System (BMS) philosophy for the inspection of bridges. This chapter will provide a brief history of BMS, provide information about BMS computer programs, and outline the procedures for performing a BMS type inspection. The instructions in this chapter are intended to supplement those in Chapter 3 “Inspections and Reports.”

The Federal Highway Administration (FHWA) requires each state to provide information about each bridge in their inventory as described in the FHWA’s Recording and Coding Guide for the Structure Inventory and Appraisal of the Nation’s Bridges. This information is used to generate a National Bridge Inventory (NBI). The FHWA categorizes bridges as structurally deficient or functionally obsolete based on their condition and appraisal ratings. Bridge eligibility for rehabilitation and replacement is determined by a sufficiency rating formula. The NBI does not provide information that can be used to predict a bridge’s future condition or provide an estimate on future maintenance and repair needs of an agency bridge inventory.

Recognizing that a different strategy towards future bridge preservation was needed, the National Cooperative Highway Research Program (NCHRP) published a report (Report 300) in December 1987 to provide the framework for a BMS. The overall objective of this report was to develop a model bridge management system that could be implemented by a state or local transportation agency. BMS is intended to ensure the effective use of available funds and identify the effects of various funding levels on an agency bridge network.

BMS is designed to provide information not currently available from NBI data. FHWA recommends agency use of BMS to provide comprehensive management of their bridge system. BMS can provide the following:

- Improvements in the type and quality of data that is collected, stored, managed, and used in a bridge system analysis.
- A logical method for setting priorities for current needs.
- Realistic and reliable forecasts of future needs.
- Ways to implement changes in management philosophies and goals.

4.01 Common BMS Bridge Elements

BMS elements are commonly used in highway bridge construction and encountered on bridge inspections. These elements are labeled “Commonly Recognized” (CoRe) structural elements because of their nationwide recognition and use. A single BMS element can incorporate only those components of a bridge that:

- Are made of the same material.
- In normal service be expected to deteriorate in a very similar fashion and at a similar rate.
- Can be inventoried with units that are easily assessed by the inspector.

The AASHTO Guide for Commonly Recognized (CoRe) Structural Elements provides basic definitions for CoRe elements. In general, all girders, trusses, arches, cables, floor beams, stringers, abutments, piers, pins and hangers, culverts, joints, bearings, railings, decks and slabs are identified as CoRe elements. AASHTO CoRe elements contain a description, definition, condition state language, a unit of measurement and a feasible action. The condition of a CoRe element is identified by condition states and corresponding condition state language. Each CoRe element has a range of 3 to 5 condition states. The first condition state (#1) would represent a like new condition while the last condition state would represent the worst condition. The AASHTO definitions have been significantly modified for use by the State of Washington.

“Smart Flags” are used to flag unique problems not identified by BMS elements. A Smart Flag can have multiple condition states. Smart-Flags do not have feasible actions associated with their condition states since the deterioration rate is not predictable. Examples of Smart Flags are Steel Fatigue (cracks in steel elements), Scour, Pack Rust, etc.

Information from each CoRe element along with expert input to predict how the condition of that element will change over time is used in BMS computer programs. The BMS programs can estimate future network funding levels based on the predicted future bridge conditions and the corresponding costs to repair or replace them.

4.02 BMS Inspections

As previously stated, a BMS inspection is intended to supplement but not replace an NBI type inspection. All procedures for bridge inspection outlined in Chapter 3 of need to be followed. The following outline provides a short BMS summary for a typical inspection and is discussed in the following paragraphs.

- A. Identify the BMS elements that apply to the structure.
- B. Determine the total quantity for each element.
- C. Inspect bridge and record the deficient quantity for each element in the corresponding condition state.

WSDOT’s Bridge Preservation Office uses a laptop computer program to allow an inspector to record information from both an NBI and a BMS type inspection. A sample Bridge Inspection Report (BIR) is shown in Chapter 3.

A. Identify the BMS Elements

Details about the design of the bridge are important when identifying the BMS elements. As-built plans provide the best resource for choosing the correct elements. Elements can be defined with as-built plans in the office prior to the inspection and then field verified. If as-built plans are not available, then the elements will have to be defined at the bridge site.

For example, let's say a bridge has a reinforced concrete bridge deck. In order to determine if the BMS coding for the concrete deck should be element No. 12 or element No. 26 the type of steel reinforcing needs to be identified. Plans and special provisions would note if the reinforcing steel in a concrete deck was epoxy coated or not. A field inspection could not accurately determine if the steel was epoxy coated thus if as-built plans are not available then the type of element would need to be assumed. It should be noted that epoxy coated rebar in bridge decks became an industry standard in Washington State in the early 1980's.

An average bridge made of the same material will have six to ten elements. A large or complex bridge may have up to 20 elements. A typical bridge will have a bridge deck, possibly a deck overlay, bridge rails, a primary load carrying member like a prestressed concrete girder, primary substructure support like concrete columns, other elements like abutments, expansion joints and/or bearings.

B. Determine the Total Quantity of the Element

The units to be used for each element are defined with the corresponding element. The units are listed as "SF" (square feet), or "LF" (lineal feet), or "EA" (each).

The "SF" value is used to determine the area of a deck element and the area of steel for paint elements. For bridge decks use the curb-to-curb width of the deck by the length to determine the deck area.

The "LF" value is used to determine the total length of an element. The length of an element is based on the way it was constructed. For example: A bridge may have been built using five "Prestressed Concrete Girders." Each one was individually pre-cast and then put into place at the bridge site. If each girder were 100 feet in length then the total element quantity would be "500 LF." If the same bridge was a "Concrete Box Girder" then the total quantity would be "100 LF" since the box girder was constructed as one unit.

The quantity for the abutment elements is determined by estimating the length along the abutment. For example; if the abutment has integral wing walls then include them in the total length. If a retaining wall is being used for the abutment and the wall extends beyond the bridge then use the bridge out to out width value plus 40 feet for the total abutment length.

The "EA" value is used to determine the number of members in a condition state. For example: A two span bridge may have been built with 5 piles at each support for a total of 15 piles in the bridge. The pile is inspected, evaluated, and recorded in the appropriate condition state.

C. Inspect the Element and Record the Quantity in the Corresponding Condition State

The first step is to review the condition state language for the elements to be inspected. A complete list of the condition state descriptions is provided in this chapter. Code the appropriate quantity of the element in the corresponding condition state or condition states. The total quantity for those with units of “EA” would be coded in one condition state while elements with units of “LF” or “SF” could have quantities in one or all of the condition states.

Element condition state (CS) language is based on four condition states for all primary structural members, regardless of the materials. Similar to the NBI system of evaluation, the BMS requires the inspector to evaluate defects and also quantify the defect’s impact to the element or possibly the bridge. Different philosophies apply to the non-primary structural elements such as deck/overlays, joints, paint, and smart flags. The following summarizes the general BMS condition state philosophy for primary structural members. It must be noted that a defect could be CS1, CS3, or CS4 depending on the location and/or quantity.

Condition State 1: Most parts of a bridge will be in this condition state for all BMS elements. The element may have some defects, but is in good condition. Many times new bridges have insignificant defects and older bridges will acquire insignificant defects with time. In order to determine if the defect is insignificant, the inspector must decide if the defect will impact the element load carrying capacity with time. Inspectors are cautioned to look at new construction that may not be CS1.

Condition State 2: This condition state documents repairs to structural members. Generally, these are easy to identify and report. Common repairs do not have the same integrity or longevity as original construction. Many times members are difficult to access and prohibit a good quality repair. Inspectors are cautioned to verify repairs to make sure they are functioning as intended. If a repair is not completed correctly or is not functioning properly, then the repair should be coded as CS3 or CS4.

Condition State 3: This condition state records any significant defect noticed by the inspector, but the defect does not significantly impact the capacity of the element. Capacity is not currently threatened, but if left unchecked, it could be threatened in the future. Repairs may apply to the elements in CS3 because the defects are more economical address now than to wait and repair later.

Condition State 4: This condition state documents members with defects that have impacted the structural capacity of the element. Based on the visual inspection, the owner of the bridge must address this deficiency in order to preserve or restore the capacity of the member and/or structure. Generally, these defects have reduced the structural capacity of the element, but are still within safe operating limits of design.

Concrete Cracking

The following table is reproduced from the Bridge Inspector’s Reference Manual (BIRM), Volume 1, Table 2.2.3; and should be used to distinguish between different sizes of concrete cracks.

Concrete Crack With Guidelines				
	Reinforced Concrete		Prestressed Concrete	
	English	Metric	English	Metric
Hairline (HL)	< 1/16"	< 1.6 mm	< 0.004"	< 0.1 mm
	(0.0625)			
Narrow (N)	1/16" to 1/8"	1.6 to 3.2 mm	0.004" to 0.009"	0.1 to 0.23 mm
	0.0625" - 0.125"			
Medium (M)	1/8" to 3/16"	3.2 to 4.8 mm	0.010" to 0.030"	0.25 to 0.76 mm
	0.125" - 0.1875"			
Wide (W)	> 3/16"	> 4.8 mm	> 0.030"	> 0.76 mm
	> 0.1875"			

Concrete Structural cracking: For the purpose of BMS coding, concrete structural cracks are narrow (or wider) in regions of high shear or moment (see BIRM). Crack width is significant to the extent that it indicates exposure of rebar to water and/or a structural problem in a concrete element. Generally, most concrete elements have hairline cracking and not considered significant structurally.

4.03 BMS Computer Programs

WSDOT currently uses the Bridgit computer program for bridge network analysis only. One of the many functions of this software is to provide guidance on how best to allocate funds in an agency bridge network. Bridgit software will allow quick answers to various “What If?” funding scenarios, providing immediate feedback needed in the budgeting and programming process. A BMS element for the environment state is controlled by the BMS Engineer and used for modeling the “What If”. This element is not coded by the bridge inspectors for the Washington bridges.

4.1 Bridge Decks

The intent of the bridge deck elements is to record the top surface deterioration. The Concrete Deck Soffit, slab, or deck-girder elements record the structural deterioration. Deck elements 12, 13, 14, 20, and 26 record deck patches in CS2, deck spalls in CS3, and delaminations in CS4. Other deck top surface distress such as cracking, scaling, and rutting are not tracked in the deck BMS condition states. These items should be described in the notes at the inspector’s discretion. Do not count filling in of the rut as a patch. These locations have filled in a rut with ACP or Ure-Fast and are not considered a deck structural repair.

All bridges will have at least one deck element, even though some bridges do not have a traditional deck and use elements 13 or 14. (The one exception is a Luten Arch structure that is earth filled with an asphalt pavement only.)

Traditional concrete bridge decks use elements 12, 20, or 26 to record the top surface deterioration; and have the Structural Concrete Deck Element (35) to record the structural deterioration.

Non-Traditional concrete decks use elements 13 or 14 to record the top surface deterioration. The slab or deck-girder elements record the structural deterioration.

Steel and Timber decks use elements 28, 29, 30, 31 to record structural condition only, since there is little need to track the wearing surface defects.

Inspectors are encouraged to take the time to locate and describe the patches and spalls on larger structures using photos and descriptions. The preferred documentation format for patching is the number and SF per span. This format is easiest for the next inspector to identify quantity changes.

Quantity estimates must be based on the sum of the estimated length and width of the patched or spalled areas. Approximations based on the percent of area are not useful.

NBI Deck Overall Condition should be coded based on Table WB76-63B Chapter 2, page 88.

12	Concrete Deck	Units - SF
-----------	----------------------	-------------------

This element defines a concrete bridge deck constructed with uncoated steel reinforcement. The quantity should equal the deck's curb-to-curb width times the length.

1. Defects are superficial. The deck surfaces have no spalls/delaminations or previous repairs. The deck surfaces may have hairline cracks or rock pockets. Wear and rutting may expose aggregate or reinforcing.
2. Deck area with repairs or patches. Do not include the rare case rutting filled with patching material.
3. Deck area with spalling.
4. If the results of deck delamination testing are available, record the delaminated area (CS4) from element 376 in the deck CS4.

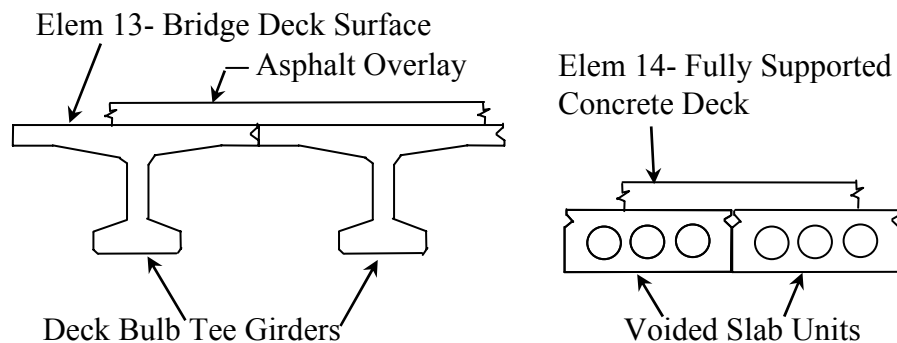

13	Bridge Deck Surface	Units - SF
-----------	----------------------------	-------------------

This element defines a surface of a bridge deck that consists of a slab or girder without a traditional deck. Usually there is a deck protection system (overlay) present, but in some cases, traffic may be driving directly on the girder or slab. The Bridge Deck Surface consists of precast or prestressed girders with no span between the flanges. This element is generally used with superstructure elements 38, 49, 50, 51, 52, 54, 108, 109, or 114. The quantity should equal the "deck" curb-to-curb width times the length.

14	Fully Supported Concrete Deck	Units - SF
-----------	--------------------------------------	-------------------

This element defines a fully supported concrete bridge deck constructed with one layer of coated reinforcement (epoxy, galvanizing, stainless steel, etc.). The bridge support surface consists of precast or prestressed girders with no span between the flanges. This element may apply to superstructure elements 50, 51, 108, 109, or 114. The quantity should equal the deck's curb-to-curb width times the length.

1. Defects are superficial. The deck surfaces have no spalls/delaminations or previous repairs. The deck surfaces have no exposed reinforcing. The deck surfaces may have hairline cracks, rock pockets and/or be worn exposing aggregate.
2. If the top of the slabs or girders are visible, area of deck with repairs.
3. If the top of the slabs or girders are visible, area of deck spalling
4. If the results of deck delamination testing are available, record the delaminated area (CS4) from element 376 in the deck CS4.

20	Concrete Deck – Lightweight Aggregate	Units - SF
-----------	----------------------------------------------	-------------------

This element defines a lightweight concrete bridge deck constructed with lightweight aggregate and steel reinforcement. The total design weight of the deck is approximately 120 lbs./C.Y. The quantity should equal the deck's curb-to-curb width times the length.

26	Concrete Deck w/Coated Bars	Units - SF
-----------	------------------------------------	-------------------

This element defines a concrete bridge deck constructed with coated (epoxy, galvanizing, stainless steel, etc.) reinforcement. The quantity should equal the deck's curb-to-curb width times the length.

1. Defects are superficial. The deck surfaces have no spalls/delaminations or previous repairs. The deck surfaces may have hairline cracks or rock pockets. Wear and rutting may expose aggregate or reinforcing.
2. Deck area with repairs or patches. Do not include the rare case rutting filled with patching material.
3. Deck area with spalling.
4. If the results of deck delamination testing are available, record the delaminated area (CS4) from element 376 in the deck CS4.

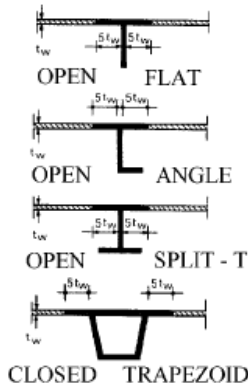

Orthotropic Deck Types

Closed Trapezoid Orthotropic Deck

27 Steel Orthotropic Deck Units - SF

This element defines a bridge deck constructed of a flat, deck plate stiffened either longitudinally or transversely, or in both directions. See BIRM, Volume 1, Figure P.1.2.7. The quantity should equal the deck's curb-to-curb width times the length.

28 Steel Deck – Open Grid Units - SF

This element defines a bridge deck constructed of steel grids that are open and unfilled. The quantity should equal the deck's curb-to-curb width times the length.

29 Steel Deck – Concrete Filled Grid Units - SF

This element defines a bridge deck constructed of steel grids with either all of the openings or just those in the wheel lines filled with concrete. The quantity should equal the deck's curb-to-curb width times the length.

30 Deck – Corrugated or Other Steel system Units - SF

This element generally defines a bridge deck constructed of corrugated metal filled with Portland cement concrete or asphaltic concrete. This element may also be used to identify other non-standard steel decks. The quantity should equal the deck's curb-to-curb width times the length.

1. Defects are superficial. The connectors (such as welds, rivets, etc.) or concrete/ asphalt filler are functioning as designed.
2. Deck area with repairs or replaced panels.
3. Deck area with structural defects. The defects do not significantly affect structural capacity. Deficiencies do not warrant analysis, but may require repairs.
4. Deck area with damage in significant locations or quantity and has reduced the structural capacity of the element. Structural analysis is warranted or has determined repairs are essential to restore the full capacity of the element.

31 Timber Deck **Units - SF**

This element defines a bridge deck constructed of timber. The deck may be longitudinally or transversely laminated or of planks. The deck may have an overlay or may be constructed with runners of metal or timber. The quantity should equal the deck's curb to curb width times the length.

1. Defects are superficial and have no effect on the structural capacity of the element. Decay, insect infestation, cracks, splits, or checks may exist.
2. Timber deck area with repairs, plates, or replaced timbers.
3. Timber deck area with structural defects. The defects do not significantly affect structural capacity. Deficiencies do not warrant analysis, but may require repairs. These areas are typically marked with a YELLOW TAG by inspectors.
4. Timber deck area with damage in significant locations or quantity and has reduced the structural capacity of the element or the bridge. Structural analysis is warranted or has determined repairs are essential to restore the full capacity of the element. These areas are typically marked with a RED TAG by inspectors.

32 Fiber Reinforced Polymer (FRP) – Deck **Units - SF**

This element defines a bridge deck constructed of fiber reinforced polymer. The quantity should equal the deck's curb to curb width times the length.

1. Defects are superficial. Cracking or delamination of layers may be present.
2. FRP Deck area with repairs, patches, or plated.
3. FRP Deck area with structural defects. The defects do not significantly affect structural capacity. Deficiencies do not warrant analysis, but may require repairs.
4. FRP Deck area with damage in significant locations or quantity and has reduced the structural capacity of the element or the bridge. Structural analysis is warranted or has determined repairs are essential to restore the full capacity of the element.

35 Concrete Deck Soffit **Units - SF**

This element defines the bottom (or undersurface) and edge of a concrete deck and is to be included with concrete deck elements 12, 20, and 26. It is extremely valuable when an asphalt overlay exists on the top surface of the deck. The purpose of the element is to identify decks that may have a reduced structural capacity through visual inspections of the deck soffit. Element 35 does not apply if steel stay-in-place forms are present on the soffit. To be consistent with the deck quantity, the deck soffit quantity should equal the deck's curb-to-curb width times the length.

Delaminations on concrete soffits over roadways may pose a danger to traffic below the bridge. In this situation, a repair should be recommended to correct the condition.

1. The undersurface of the deck is not showing signs of distress. There may be rust stains from rebar chairs, spalls without exposed rebar, or cracks with efflorescence.
2. Deck soffit area with repairs or patches.



3. Deck soffit area showing signs of reduced structural capacity. Typical indications include areas with heavy to severe rust staining from deck reinforcement; Spalling with corroded rebar indicating active corrosion; Cracks that are full depth, severe, or leaking water.



36 Deck Rebar Cover Flag **Units - SF**

This does not apply to deck spalling with exposed rebar. This element is used to identify the top surface of bridge decks with concrete cover less than 1 inch and having rebar exposed. This condition results from either lack of cover during construction or general rutting that has exposed rebar. Deck patching is often difficult at these locations. This flag will determine method of deck rehabilitation. Report square foot of visible deficiency in CS2.

1. Deck top surface area with adequate concrete cover.
2. Concrete deck area with visible lack of cover due to construction or general rutting that has exposed rebar.

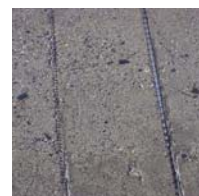

4.2 Superstructure

Girders

A girder is defined as any longitudinal structural member (single web or box section) that directly supports the bridge deck. A girder type bridge will typically have two or more girders. Girders may be constructed of the following typical materials: Rolled, welded, bolted (riveted), steel sections; Post tensioned, prestressed or reinforced concrete sections; or Timber sections.

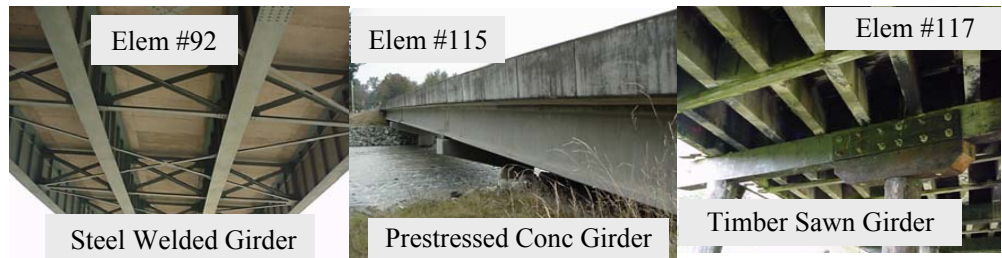
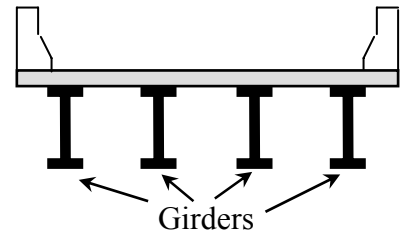

Diaphragms

Diaphragms are structural members used to tie adjoining girders together to improve the strength and rigidity of the girder and to distribute forces in the lateral direction. There is no BMS element defined for a diaphragm. If a diaphragm has advanced deterioration, it should be noted in the BMS comments of the accompanying girder.

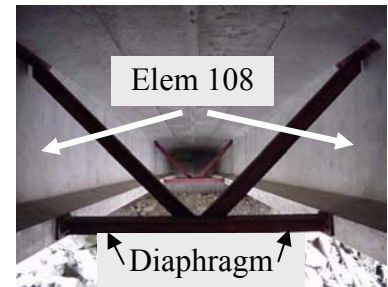

Pedestrian Bridges

The same BMS elements used for bridges that carry vehicular traffic can be used for pedestrian bridges. **Do not use the BMS sidewalk elements (#260 through #266) for pedestrian bridges.**



Slab Bridges

Slab bridges can have precast segments or cast in place concrete. The bridge in the picture is a cast in place concrete slab and will have a deck element for the deterioration of the top surface. Structural deficiencies of the slab bottom and edge are documented in BMS element #38 “Concrete Slab”.



38 Concrete Slab Units - SF

This element defines a concrete slab bridge and edge that has been constructed with uncoated reinforcement. Structural deficiencies of the edge and bottom surface are addressed in the condition states. The slab quantity should equal the slab’s curb-to-curb width times the length.

49 Concrete Hollow Slab Units - SF

This element defines a concrete slab bridge and edge that has been constructed with sono-tubes and uncoated reinforcement. Structural deficiencies of the edge and bottom surface are addressed in the condition states. This type of bridge was typically built in the 50’s and 60’s on the state highway system. The slab quantity should equal the slab’s curb-to-curb width times the length.

50 Prestressed Concrete Slab Units - SF

This element defines a concrete slab bridge that has been constructed with prestressed concrete and uncoated steel reinforcement. Structural deficiencies of the edge and bottom surface are addressed in the condition states. The slab quantity should equal the slab’s curb-to-curb width times the length.

51 Prestressed Concrete Slab w/Coated Bars Units - SF

This element defines a concrete slab bridge that has been constructed with prestressed concrete and coated steel reinforcement (epoxy, etc.). This element may be solid or have built in voids. Structural deficiencies of the edge and bottom surface are addressed in the condition states. The slab quantity should equal the slab’s curb-to-curb width times the length.

52 Concrete Slab w/Coated Bars Units - SF

This element defines a concrete slab bridge and edge that has been constructed with coated (epoxy, etc.) reinforcement. This element may or may not contain a hollow core. Structural deficiencies of the edge and bottom surface are addressed in the condition states. The slab quantity should equal the slab's curb-to-curb width times the length.

1. Defects are superficial and have no effect on the structural capacity of the element. There may be discoloration, efflorescence, and/or superficial cracking, spalls or delaminations.
2. Concrete slab area with repairs or patches.
3. Concrete slab area with structural defects. The defects do not significantly affect structural capacity. Deficiencies do not warrant analysis, but may require repairs.
4. Concrete slab area with damage in significant locations or quantity and has reduced the structural capacity of the element or the bridge. Structural analysis is warranted or has determined repairs are essential to restore the full capacity of the element.



54 Timber Slab Units - SF

This element defines a slab that is constructed of timber. Structural deficiencies of the edge and bottom surface are addressed in the condition states. The slab quantity should equal the slab's curb-to-curb width times the length.

1. Defects are superficial and have no effect on the structural capacity of the element. Decay, insect infestation, cracks, splits, or checks may exist.
2. Slab area with repairs, plates or replaced timbers.
3. Slab area with structural defects. The defects do not significantly affect structural capacity. Deficiencies do not warrant analysis, but may require repairs. These areas are typically marked with a YELLOW TAG by inspectors.
4. Slab area with damage in significant locations or quantity and has reduced the structural capacity of the element or the bridge. Structural analysis is warranted or has determined repairs are essential to restore the full capacity of the element. These areas are typically marked with a RED TAG by inspectors.

89	Prestressed Concrete Girder W/Coated Strands	Units - LF
-----------	-----------------------------------------------------	-------------------

This element defines a girder constructed of precast prestressed concrete and epoxy coated strand that supports the bridge deck. The element quantity should equal the sum of each girder length. The total element quantity should equal the length of each girder multiplied by the number of girders.

1. Defects are superficial and have no effect on the structural capacity of the element. There may be discoloration, efflorescence, and/or superficial cracking, spalls or delaminations.
2. Girder length affected by repair or patch. Capacity repairs such as a strand splicing should record girder span length.
3. Girder length affected by defects. The defects do not significantly affect structural capacity. Deficiencies do not warrant analysis, but may require repairs. Girder with defects such as: delaminations, spalls, structural cracking, exposed or corroded reinforcing or strands.

4. Girder span length with damage in significant locations or quantity and has reduced the structural capacity of the element or the bridge. Structural analysis is warranted or has determined repairs are essential to restore the full capacity of the element.



90	Steel Rolled Girder	Units - LF
-----------	----------------------------	-------------------

This element defines a girder unit of structural steel that has an integral web and flanges and was fabricated in a steel mill by the rolling process. This element may have bolted, riveted or welded cover plates. This element directly supports the bridge deck and is part of a two or more longitudinal girder system. The element quantity should equal the length of each girder multiplied by the number of girders.

91	Steel Riveted Girder	Units - LF
-----------	-----------------------------	-------------------

This element defines a girder unit of structural steel that directly support the bridge deck. This element has a web and flanges that are connected with rivets. This element is part of a two or more longitudinal girder system. The element quantity should equal the length of each girder multiplied by the number of girders.

92	Steel Welded Girder	Units - LF
-----------	----------------------------	-------------------

This element defines a girder unit of structural steel that directly support the bridge deck. This element has a web and flanges that are connected with welds. This element is part of a two or more longitudinal girder system. The element quantity should equal the sum of each girder length.

1. Defects are superficial and have no effect on the structural capacity of the element.
2. Girder span length with repairs such as: bolts or rivets have been replaced; cracks that have been drilled or plated.
3. Girder span length with structural defects. The defects do not significantly affect structural capacity. Deficiencies do not warrant analysis, but may require repairs. Structural deficiencies are not limited to impact damage, cracks, broken bolts, or measurable section loss due to corrosion (note the location and depth).
4. Girder span length with damage in significant locations or quantity and has reduced the structural capacity of the element or the bridge. Structural analysis is warranted or has determined repairs are essential to restore the full capacity of the element. Structural deficiencies are not limited to impact damage, corrosion, a crack in primary load path member or in the attachment welded to primary member. Retain the quantity of the element reported in CS4 if the element is repainted but not repaired.

96	Concrete Encased Steel Girder	Units - LF
-----------	--------------------------------------	-------------------

This element defines a steel girder that is encased in concrete. The element quantity should equal the length of each girder multiplied by the number of girders.

1. Defects are superficial and have no effect on the structural capacity of the element. There may be discoloration, efflorescence, and/or superficial cracking.
2. Girder span length with repairs or patches.
3. Girder span length with structural defects. The defects do not significantly affect structural capacity. Deficiencies do not warrant analysis, but may require repairs. Structural deficiencies are not limited to impact damage, cracks, broken bolts, or measurable section loss due to corrosion (note the location and depth), concrete delaminations or spalls in a tension zone.
4. Girder span length with damage in significant locations or quantity and has reduced the structural capacity of the element or the bridge. Structural analysis is warranted or has determined repairs are essential to restore the full capacity of the element.

97	Prestressed Concrete Trapezoidal Girder	Units - LF
-----------	------------------------------------------------	-------------------

This element defines a prestressed concrete box girder. Post-tensioning and span field splices may or may not be present. The element quantity should equal the sum of each girder length. The total element quantity will equal the length of each girder multiplied by the number of girders.

1. Defects are superficial and have no effect on the structural capacity of the element. There may be discoloration, efflorescence, and/or superficial cracking, spalls or delaminations.
2. Girder length affected by repair or patch. Capacity repairs such as a strand splicing should record girder span length.
3. Girder length affected by defects. The defects do not significantly affect structural capacity. Deficiencies do not warrant analysis, but may require repairs. Girder with defects such as: delaminations, spalls, structural cracking, exposed or corroded reinforcing or strands.
4. Girder span length with damage in significant locations or quantity and has reduced the structural capacity of the element or the bridge. Structural analysis is warranted or has determined repairs are essential to restore the full capacity of the element.

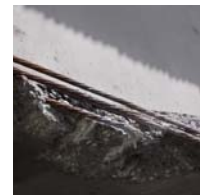

98	Pontoon Hatch/Bulkhead	Units - EA
-----------	-------------------------------	-------------------

This element defines a steel deck or bulkhead hatch access. Deck hatches are accessed from the exterior of a pontoon and bulkhead hatches provide access between cells. The condition evaluation of a hatch includes, but is not limited to the ability of a hatch to provide a watertight structural seal. The performance of the hatches are critical to the design buoyancy of the pontoon structure during extreme events. The total element quantity should equal the total number of hatch and bulkheads on a bridge.

1. Defects are superficial and are insignificant to performance of the hatch. Insignificant amounts of water enter a cell when a deck hatch is opened.
2. Number of hatch/bulkheads with repairs such as: replaced seals, repaired hold-down dogs or locks.
3. Number of hatch/bulkheads with structural defects. The defects do not threaten performance of the hatch.
4. Number of hatch/bulkheads with damage that threatens performance during an extreme event. All pontoon cells, element 99, threatened by the damaged port are to be coded CS4.



99 Concrete Floating Pontoon Units - Cell

This element is defined by the bottom, sides, and interior cell walls of a concrete floating pontoon. Pontoon element condition will include the top where elevated decks exist on the pontoon. Note: Deck elements will apply for the entire length of the pontoon structure. The structural condition evaluation of the pontoon includes, but is not limited to, the concrete, post-tensioning, exterior hatches, and connections between pontoons. Maintenance pumping records are applied to assess the risk of flooding a cell and/or pontoon. The total element quantity should equal the total number of pontoon cells for the bridge.

1. Defects are superficial and are insignificant to structural capacity or buoyancy. Insignificant amounts of water may be present due to condensation or when a deck hatch is opened. If the total quantity is in CS1, then the NBI Substructure Condition rating (FHWA Item 060) shall be a 7 or 8.
2. Number of pontoon cells with concrete repairs, patches or injected cracks. If one pontoon cell is in CS2, then the NBI Substructure Condition rating (FHWA Item 060) shall be a maximum of 6.
3. Number of pontoon cells structural defects. The defects do not threaten structural capacity or buoyancy of the cell. Water is present in the cell and remains unchanged from year to year and pumping is not required.
4. Number of pontoon cells with structural damage that threatens structural capacity or buoyancy of the cell, pontoon or bridge. Water is accumulating in a cell from a known or unknown source and requires pumping. A cell with visually leaking cracks. If one pontoon cell is in CS4, then the NBI Substructure Condition rating (FHWA Item 060) shall be a maximum of 4. See Bridge Inspection Report, Element 99 BMS notes for pontoon cell criteria that justifies an NBI Substructure Condition rating (FHWA Item 060) of 3.

100 Post Tensioned Concrete Segmental Box Girder Units - LF

This element defines a post-tensioned concrete box girder constructed using the segmental precast process. The quantity should equal the total length of segmental box girders.

1. Defects are superficial and have no effect on the structural capacity of the element. There may be discoloration, efflorescence, and/or superficial cracking, spalls or delaminations.
2. Girder length affected by repair or patch. Capacity repairs such as a strand splicing should record girder span length.
3. Girder length affected by defects. The defects do not significantly affect structural capacity. Deficiencies do not warrant analysis, but may require repairs. Girder with defects such as: delaminations, spalls, structural cracking, exposed or corroded reinforcing or strands. 
4. Girder span length with damage in significant locations or quantity and has reduced the structural capacity of the element or the bridge. Structural analysis is warranted or has determined repairs are essential to restore the full capacity of the element. 

102 Steel Box Girder Units - LF

This element defines a box girder unit constructed with structural steel. This element directly supports the bridge deck. The element quantity should equal the length of each girder multiplied by the number of girders.

1. Defects are superficial and have no effect on the structural capacity of the element.
2. Girder span length with repairs such as: bolts or rivets have been replaced; cracks that have been drilled or plated.
3. Girder span length with structural defects. The defects do not significantly affect structural capacity. Deficiencies do not warrant analysis, but may require repairs. Structural deficiencies are not limited to impact damage, cracks, broken bolts, or measurable section loss due to corrosion (note the location and depth).
4. Girder span length with damage in significant locations or quantity and has reduced the structural capacity of the element or the bridge. Structural analysis is warranted or has determined repairs are essential to restore the full capacity of the element. Structural deficiencies are not limited to impact damage, corrosion, a crack in primary load path member or in the attachment welded to primary member. Retain the quantity of the element reported in CS4 if the element is repainted but not repaired.

103 Prestressed Concrete Super Girder **Units - LF**

This element defines a prestressed WSDOT type W83G, WF83G, W95G, or WF95G girder. Girders may or may not be post-tensioned. The element quantity should equal the total length of each girder multiplied by the number of girders.

104 Post Tension Concrete Box Girder **Units - LF**

This element defines a box girder unit constructed of post-tensioned, cast in place concrete. The element quantity should equal the length of each girder multiplied by the number of girders.

105 Concrete Box Girder **Units - LF**

This element defines a box girder superstructure unit constructed with cast in place reinforced concrete. The element quantity should equal the total length of box girders.

1. Defects are superficial and have no effect on the structural capacity of the element. There may be discoloration, efflorescence, and/or superficial cracking, spalls or delaminations.
2. Girder length affected by repair or patch. Capacity repairs such as a strand splicing should record girder span length.
3. Girder length affected by defects. The defects do not significantly affect structural capacity. Deficiencies do not warrant analysis, but may require repairs. Girder with defects such as: delaminations, spalls, structural cracking, exposed or corroded reinforcing or strands.
4. Girder length affected by damage in significant locations or quantity and has reduced the structural capacity of the element or the bridge. Structural analysis is warranted or has determined repairs are essential to restore the full capacity of the element.





107 Steel Open Girder

Units - LF

This element defines an open girder unit that is constructed of structural steel. An open or “through” girder is part of a two girder system with stringer and floor beam elements that support a bridge deck. Open girders are located on the outside of the bridge. The bridge deck and any sidewalks are contained between the open girders. Bridges with open girders were generally built prior to 1950 and usually have built up riveted steel members. The element quantity should equal the length of each girder multiplied by the number of girders.

1. Defects are superficial and have no effect on the structural capacity of the element.
2. Steel open girder span length with repairs such as: bolts or rivets have been replaced; cracks that have been drilled or plated.
3. Steel open girder span length with structural defects. The defects do not significantly affect structural capacity. Deficiencies do not warrant analysis, but may require repairs. Structural deficiencies are not limited to impact damage, cracks, broken bolts, or measurable section loss due to corrosion (note the location and depth).
4. Steel open girder span length with damage in significant locations or quantity and has reduced the structural capacity of the element or the bridge. Structural analysis is warranted or has determined repairs are essential to restore the full capacity of the element. Structural deficiencies are not limited to impact damage, corrosion, a crack in primary load path member or in the attachment welded to primary member. Retain the quantity of the element reported in CS4 if the element is repainted but not repaired.

108 Prestressed Concrete Bulb-T Girder

Units - LF

This element defines a precast prestressed concrete Bulb-T girder unit. Structural deficiencies of the edge and bottom surface are addressed in the condition states. The element quantity should equal the length of each girder multiplied by the number of girders.

109 Prestressed Concrete Multiple Web Girder Units

Units - LF

This element defines a precast prestressed concrete girder that has more than one web. Structural deficiencies of the edge and bottom surface are addressed in the condition states. The element quantity should equal the length of each girder unit. The total element quantity should equal the length of each girder unit multiplied by the number of girders.

110 Concrete Girder

Units - LF

This element defines a girder (including T-Beams) constructed of non-prestressed reinforced concrete. The element quantity should equal the length of each girder multiplied by the number of girders.

1. Defects are superficial and have no effect on the structural capacity of the element. There may be discoloration, efflorescence, and/or superficial cracking, spalls or delaminations.
2. Girder length affected by repair or patch. Capacity repairs such as a strand splicing should record girder span length.
3. Girder length affected by defects. The defects do not significantly affect structural capacity. Deficiencies do not warrant analysis, but may require repairs. Girder with defects such as: delaminations, spalls, structural cracking, exposed or corroded reinforcing or strands.



4. Girder span length with damage in significant locations or quantity and has reduced the structural capacity of the element or the bridge. Structural analysis is warranted or has determined repairs are essential to restore the full capacity of the element.



111 Timber Glue-Lam Girder

Units - LF

This element defines a girder unit constructed of glue-lam timber. This element directly supports the bridge deck. The element quantity should equal the length of each girder multiplied by the number of girders.

1. Defects are superficial and have no effect on the structural capacity of the element. Decay, insect infestation, cracks, splits, or checks may exist.
2. Glue-Lam girder span length with repairs, patches, or plated.
3. Glue-Lam girder span length with structural defects. The defects do not significantly affect structural capacity. Deficiencies do not warrant analysis, but may require repairs. These areas are typically marked with a YELLOW TAG by inspectors.
4. Glue-Lam girder span length with damage in significant locations or quantity and has reduced the structural capacity of the girder or the bridge. Structural analysis is warranted or has determined repairs are essential to restore the full capacity of the element. These areas are typically marked with a RED TAG by inspectors.

113	Steel Stringer	Units - LF
------------	-----------------------	-------------------

This element defines a stringer constructed of structural steel that supports the deck in a stringer-floor beam system. A stringer is connected to a floor beam and directly supports a bridge deck. A steel stringer and floor beam combination is commonly used in steel truss and steel open girder bridges. The element quantity should equal the length of each stringer multiplied by the number of stringers.



1. Defects are superficial and have no effect on the structural capacity of the element.
2. Stringer span length with repairs such as: bolts or rivets have been replaced; cracks that have been drilled or plated.
3. Stringer span length with structural defects. The defects do not significantly affect structural capacity. Deficiencies do not warrant analysis, but may require repairs. Structural deficiencies are not limited to impact damage, cracks, broken bolts, or measurable section loss due to corrosion (note the location and depth).
4. Stringer span length with damage in significant locations or quantity and has reduced the structural capacity of the element or the bridge. Structural analysis is warranted or has determined repairs are essential to restore the full capacity of the element. Structural deficiencies are not limited to impact damage, corrosion, a crack in primary load path member or in the attachment welded to primary member. Retain the quantity of the element reported in CS4 if the element is repainted but not repaired.

114	Concrete Multiple Web Girder Unit	Units - LF
------------	------------------------------------------	-------------------

This element defines a girder constructed of non-prestressed reinforced precast concrete. Structural deficiencies of the edge and bottom surface are addressed in the condition states. The element quantity should equal the length of each unit multiplied by the number of units. Check the NBIS main span type.

115	Prestressed Concrete Girder	Units - LF
------------	------------------------------------	-------------------

This element defines a girder constructed of precast prestressed concrete that supports the bridge deck. The element quantity should equal the sum of each girder length. The element quantity should equal the length of each girder multiplied by the number of girders.

116 Concrete Stringer **Units - LF**

This element defines a stringer constructed of reinforced concrete that supports the bridge deck in a stringer-floor beam system. The element quantity should equal the length of each stringer multiplied by the number of stringers. See Steel Stringers and Floor Beams for a more general description.

1. Defects are superficial and have no effect on the structural capacity of the element. There may be discoloration, efflorescence, and/or superficial cracking, spalls or delaminations.
2. Girder length affected by repair or patch. Capacity repairs such as a strand splicing should record girder span length.
3. Girder length affected by defects. The defects do not significantly affect structural capacity. Deficiencies do not warrant analysis, but may require repairs. Girder with defects such as: delaminations, spalls, structural cracking, exposed or corroded reinforcing or strands.



4. Girder span length with damage in significant locations or quantity and has reduced the structural capacity of the element or the bridge. Structural analysis is warranted or has determined repairs are essential to restore the full capacity of the element.



117 Timber Sawn Girder **Units - LF**

This element defines a girder constructed of sawn timber that supports the bridge deck. The element quantity should equal the length of each girder multiplied by the number of girders.

118 Timber Stringer **Units - LF**

This element defines a stringer constructed of timber that supports the bridge deck. The element quantity should equal the length of each stringer multiplied by the number of stringers. See Steel Stringers, Element 113, for a more general description.

1. Defects are superficial and have no effect on the structural capacity of the element. Decay, insect infestation, cracks, splits, or checks may exist.
2. Girder or stringer span length with repairs or plates.
3. Girder or stringer span length with structural defects. The defects do not significantly affect structural capacity. Deficiencies do not warrant analysis, but may require repairs. Typically, locations in a load path with a 1½" to 3" shell thickness are marked with a YELLOW TAG.
4. Girder or stringer span length with damage in significant locations or quantity and has reduced the structural capacity of the element or the bridge. Structural analysis is warranted or has determined repairs are essential to restore the full capacity of the element. Typically, locations in a load path with less than a 1½" shell thickness are marked with a RED TAG.

119 Concrete Truss **Units - LF**

This element defines all members in a truss that is constructed of concrete. There is only one concrete truss on the state highway system. The truss quantity should equal the sum of each concrete truss length, which is two times the truss span length.

1. Truss panel length with superficial defects that have no effect on the structural capacity of the element. There may be discoloration, efflorescence, and/or superficial cracking, spalls or delaminations.
2. Truss panel length with repairs or patches.
3. Truss panel length affected with structural defects. The defects do not significantly affect structural capacity. Defects do not warrant analysis, but may require repairs. Length of truss with defects such as: delaminations, spalls, structural cracking, exposed or corroded reinforcing or strands.



4. Length of truss affected with damage in significant locations or quantity and has reduced the structural capacity of the element or the bridge. Structural analysis is warranted or has determined repairs are essential to restore the full capacity of the element.



126 Steel Thru Truss **Units - LF**

This element includes all structural steel truss members. Code this element for through and pony trusses only. The truss quantity should equal the sum of each truss length, which is two times the truss span length.

131 Steel Deck Truss **Units - LF**

This element includes all truss members of a structural steel deck truss. The top and bottom chords are included in this element. The truss quantity should equal the sum of each truss length, which is two times the truss span length.

1. Defects are superficial and have no effect on the structural capacity of the element.
2. Truss panel length with repairs such as: bolts or rivets have been replaced; cracks that have been drilled or plated.
3. Truss panel length with structural defects. The defects do not significantly affect structural capacity. Deficiencies do not warrant analysis, but may require repairs. Structural deficiencies are not limited to impact damage, cracks, broken bolts, or measurable section loss due to corrosion (note the location and depth).
4. Truss panel length affected by damage in significant locations or quantity and has reduced the structural capacity of the element or the bridge. Structural analysis is warranted or has determined repairs are essential to restore the full capacity of the element. Structural deficiencies are not limited to impact damage, corrosion, a crack in primary load path member or in the attachment welded to primary member. Retain the quantity of the element reported in CS4 if the element is repainted but not repaired.

135 Timber Truss **Units - LF**

This element defines a truss constructed of timber members. The truss quantity should equal the sum of each truss length, which is two times the truss span length.

1. Truss panel length with defects that are superficial and have no effect on the structural capacity of the element. Decay, insect infestation, cracks, splits, or checks may exist.
2. Truss panel length with repairs or plates.
3. Truss panel length with structural defects. The defects do not significantly affect structural capacity. Deficiencies do not warrant analysis, but may require repairs. Typically, locations in a load path with a 1½" to 3" shell thickness are marked with a YELLOW TAG.
4. Truss panel length affected by damage in significant locations or quantity and has reduced the structural capacity of the element or the bridge. Structural analysis is warranted or has determined repairs are essential to restore the full capacity of the element. Typically, locations in a load path with less than a 1½" shell thickness are marked with a RED TAG.

139 Timber Arch **Units - LF**

This element includes all members of an arch constructed of Timber. The element quantity should equal the length measured from one arch support to the other.

1. Arch panel length with defects that are superficial and have no effect on the structural capacity of the element. Decay, insect infestation, cracks, splits, or checks may exist.
2. Arch panel length with repairs or plates.
3. Arch panel length with structural defects. The defects do not significantly affect structural capacity. Deficiencies do not warrant analysis, but may require repairs. Typically, locations in a load path with a 1½" to 3" shell thickness are marked with a YELLOW TAG.
4. Arch panel length affected by damage in significant locations or quantity and has reduced the structural capacity of the element or the bridge. Structural analysis is warranted or has determined repairs are essential to restore the full capacity of the element. Typically, locations in a load path with less than a 1½" shell thickness are marked with a RED TAG.

141 Steel Arch **Units - LF**

This element includes only the arch constructed of structural steel. When coding NBI, pier caps, cross beams, and any other coded substructure elements within the arch span are considered superstructure elements. The element quantity should equal the length measured from one arch support to the other.

142	Steel Tied Arch	Units - LF
------------	------------------------	-------------------

This element includes all members of a tied arch constructed of structural steel. The bottom and top chords are included in this element. The element quantity should equal the length measured from one arch support to the other.

1. Arch panel length with defects that are superficial and have no effect on the structural capacity of the element.
2. Arch panel length with repairs such as: bolts or rivets have been replaced; cracks that have been drilled or plated.
3. Arch panel length with structural defects. The defects do not significantly affect structural capacity. Deficiencies do not warrant analysis, but may require repairs. Structural deficiencies are not limited to impact damage, cracks, broken bolts, or measurable section loss due to corrosion (note the location and depth).
4. Arch panel length affected by damage in significant locations or quantity and has reduced the structural capacity of the element or the bridge. Structural analysis is warranted or has determined repairs are essential to restore the full capacity of the element. Structural deficiencies are not limited to impact damage, corrosion, a crack in primary load path member or in the attachment welded to primary member. Retain the quantity of the element reported in CS4 if the element is repainted but not repaired.

143	Steel Suspender	Units - EA
------------	------------------------	-------------------

This element defines a steel suspender used in a suspension bridge. The quantity should equal the total number of suspenders.

1. Number of suspenders with defects that are superficial and have no effect on the structural capacity of the element.
2. Number of suspenders with repairs such as: bolts or rivets have been replaced; cracks that have been drilled or plated.
3. Number of suspenders with structural defects. The defects do not significantly affect structural capacity. Deficiencies do not warrant analysis, but may require repairs. Structural deficiencies are not limited to impact damage, cracks, broken bolts, or measurable section loss due to corrosion (note the location and depth).
4. Number of suspenders with damage in significant locations or quantity and has reduced the structural capacity of the element or the bridge. Structural analysis is warranted or has determined repairs are essential to restore the full capacity of the element. Structural deficiencies are not limited to impact damage, corrosion, a crack in primary load path member or in the attachment welded to primary member. Retain the quantity of the element reported in CS4 if the element is repainted but not repaired.

144 Concrete Arch **Units - LF**

This element only defines the arch (open/closed spandrel, bowstring, etc.) and is constructed of non-prestressed reinforced concrete. When coding NBI, pier caps, cross beams, and any other coded substructure elements within the arch span are considered superstructure elements. The element quantity should equal the length measured from one arch foundation to the other.

1. Arch panel length with defects that are superficial and have no effect on the structural capacity of the element. There may be discoloration, efflorescence, and/or superficial cracking, spalls or delaminations.
2. Arch panel length with repairs or patches.
3. Arch panel length with structural defects. The defects do not significantly affect structural capacity. Deficiencies do not warrant analysis, but may require repairs. Arch with defects such as: delaminations, spalls, structural cracking, exposed or corroded reinforcing or strands.
4. Arch panel length affected by damage in significant locations or quantity and has reduced the structural capacity of the element or the bridge. Structural analysis is warranted or has determined repairs are essential to restore the full capacity of the element.

145 Earth Filled Concrete Arch **Units - LF**

This element defines an earth filled (Luten) arch constructed of reinforced concrete. The element quantity should equal the length measured from one arch foundation to the other. If there is a concrete deck constructed on the fill, BMS element 14 applies. If there is an ACP wearing surface, BMS element 800 or 801 applies.

1. Arch span length with defects that are superficial and have no effect on the structural capacity of the element. There may be discoloration, efflorescence, and/or superficial cracking, spalls or delaminations.
2. Arch span length with repairs or patches.
3. Arch span length with structural defects. The defects do not significantly affect structural capacity. Deficiencies do not warrant analysis, but may require repairs. Arch with defects such as: delaminations, spalls, structural cracking, exposed or corroded reinforcing or strands.
4. Arch span length affected by damage in significant locations or quantity and has reduced the structural capacity of the element or the bridge. Structural analysis is warranted or has determined repairs are essential to restore the full capacity of the element.



146	Suspension – Main Cable	Units - EA
------------	--------------------------------	-------------------

This element defines a main steel cable used to support the superstructure in a suspension bridge.

147	Suspension – Suspender Cable	Units - EA
------------	-------------------------------------	-------------------

This element defines a suspender steel cable that connects the bridge superstructure to the main suspension cable.

1. Number of cables or anchors with no defects in the cable or anchor and the protective coating system is functioning properly. New replacement cables are coded in this condition state.
2. Number of cables or anchors with defects that are insignificant and do not effect the capacity of the cable. The protective coating system is showing signs of failure, and surface or freckled rust may exist with no significant loss of section.
3. Number of cables or anchors with defects that are beginning to affect the capacity of the cable, but are within acceptable design limits. Corrosion section loss is present. Single wire failures of the cable may exist, but no closer than 30 feet apart.
4. Number of cables or anchors with defects that have significantly affected the capacity. Two or more broken wires, or equivalent section loss due to other defects, are within 30 feet.

148 Floating Bridge – Anchor Cable **Units - EA**

This element defines a steel anchor cable used in a floating bridge. The condition of a floating pontoon anchor cable is evaluated during underwater inspections performed by divers and remotely operated vehicles. Condition evaluation is based on cable protection system, breakage of wires within the cable and the condition of the cable anchor. The total element quantity should equal the number of floating pontoon anchor cables attached to the bridge.

1. Number of cables or anchors with no defects in the cable or anchor and the galvanized protection system is functioning properly. New replacement cables are coded in this condition state. (Corresponds to NBI substructure rating of 7 or 8)
2. Number of cables or anchors with defects that are insignificant and do not effect the capacity of the cable. The galvanized protection system is showing signs of failure, and surface or freckled rust may exist with no significant loss of section. If any portion of the cable or anchor is CS2, then the NBI Substructure Condition rating (FHWA Item 060) shall be a maximum of 6.
3. Number of cables or anchors with defects that are beginning to affect the capacity of the cable, but are within acceptable design limits. Corrosion section loss is present. Single wire failures of the cable may exist due to corrosion or hydrogen embrittlement, but no closer than 30 feet apart.
4. Number of cables or anchors with defects that have significantly affected the capacity. Two or more broken wires, or equivalent section loss due to other defects, are within 30 feet. If any portion of the cable or anchor is CS4, then the NBI Substructure Condition rating (FHWA Item 060) shall be a maximum of 4. If two or more adjacent cables (on the same side or opposite sides of the pontoon) or more than four cables on the structure are CS4, then the NBI Substructure Condition rating (FHWA Item 060) shall be 3.

149 Cable Stayed Bridge – Cable **Units - EA**

This element defines a steel cable used to support the superstructure in a cable stayed bridge.

1. There are no defects in the cable or anchor and the protective coating system is functioning properly. New replacement cables are coded in this condition state.
2. Number of cables or anchors with defects that are insignificant and do not effect the capacity of the cable. The protective coating system is showing signs of failure, and surface or freckled rust may exist with no significant loss of section.
3. Number of cables or anchors with defects that are beginning to affect the capacity of the cable, but are within acceptable design limits. Corrosion section loss is present. Single wire failures of the cable may exist, but no closer than 30 feet apart.
4. Number of cables or anchors with defects that have affected the capacity. Two or more broken wires, or equivalent section loss due to other defects, are within 30 feet.

150 Concrete Column on Spandrel Arch

Units - EA

This element defines the column supports on a spandrel arch bridge. The element quantity is the number of columns supported by the arch.

1. Defects are superficial and have no effect on the structural capacity of the element. There may be discoloration, efflorescence, and/or superficial cracking, spalls or delaminations.
2. Number of columns with repairs or patches.
3. Number of columns with structural defects. The defects do not significantly affect structural capacity. Deficiencies do not warrant analysis, but may require repairs. Element with defects such as: delaminations, spalls, structural cracking, exposed or corroded reinforcing or strands.
4. Number of columns with damage in significant locations or quantity and has reduced the structural capacity of the element or the bridge. Structural analysis is warranted or has determined repairs are essential to restore the full capacity of the element.



152 Steel Floor Beam

Units - LF

This element defines a floor beam constructed of structural steel that supports stringers in a stringer-floor beam system. Floor beams are load carrying elements located transversely to the general bridge alignment. Floor beams transmit the loads from the deck and/or stringers to the outside open girders or to the bottom chord of a truss bridge. The element quantity should equal the length of each floor beam multiplied by the number of floor beams.



1. Defects are superficial and have no effect on the structural capacity of the element.
2. Floorbeam span length with repairs such as: bolts or rivets have been replaced; cracks that have been drilled or plated.
3. Floorbeam span length with structural defects. The defects do not significantly affect structural capacity. Deficiencies do not warrant analysis, but may require repairs. Structural deficiencies are not limited to impact damage, cracks, broken bolts, or measurable section loss due to corrosion (note the location and depth).
4. Floorbeam span length with damage in significant locations or quantity and has reduced the structural capacity of the element or the bridge. Structural analysis is warranted or has determined repairs are essential to restore the full capacity of the element. Structural deficiencies are not limited to impact damage, corrosion, a crack in primary load path member or in the attachment welded to primary member. Retain the quantity of the element reported in CS4 if the element is repainted but not repaired.

154 Prestressed Concrete Floor Beam **Units - LF**

This element defines a floor beam constructed of prestressed concrete that supports the bridge deck in a stringer-floor beam system. The element quantity should equal the length of each floor beam multiplied by the number of floor beams.

155 Concrete Floor Beam **Units - LF**

This element defines a floor beam constructed of reinforced concrete that supports the bridge deck in a stringer-floor beam system. Floor beams are load carry elements located transversely to the general bridge alignment. Floor beams transmit the loads from the deck and/or stringers to the outside open girders. The element quantity should equal the length of each floor beam multiplied by the number of floor beams.

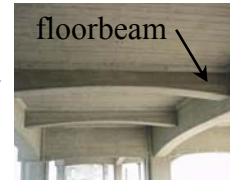

1. Defects are superficial and have no effect on the structural capacity of the element. There may be discoloration, efflorescence, and/or superficial cracking, spalls or delaminations.

2. Floorbeam span length with repairs or patches.

3. Floorbeam length affected by structural defects. The defects do not significantly affect structural capacity. Deficiencies do not warrant analysis, but may require repairs. Girder with defects such as: delaminations, spalls, structural cracking, exposed or corroded reinforcing or strands.



4. Floorbeam span length with damage in significant locations or quantity and has reduced the structural capacity of the element or the bridge. Structural analysis is warranted or has determined repairs are essential to restore the full capacity of the element.



156	Timber Floor Beam	Units - LF
------------	--------------------------	-------------------

This element defines a stringer constructed of timber that supports the bridge deck. The element quantity should equal the length of each floor beam multiplied by the number of floor beams. See Steel Floorbeam, Element 152, for a more general description.

1. Defects are superficial and have no effect on the structural capacity of the element. Decay, insect infestation, cracks, splits, or checks may exist.
2. Floorbeam span length with repairs or plates.
3. Floorbeam span length with structural defects. The defects do not significantly affect structural capacity. Deficiencies do not warrant analysis, but may require repairs. Typically, locations in a load path with a 1½" to 3" shell thickness are marked with a YELLOW TAG.
4. Floorbeam span length with damage in significant locations or quantity and has reduced the structural capacity of the element or the bridge. Structural analysis is warranted or has determined repairs are essential to restore the full capacity of the element. Typically, locations in a load path with less than a 1 ½ shell thickness are marked with a RED TAG.

160	Steel Column on Spandrel Arch	Units - EA
------------	--------------------------------------	-------------------

This element defines the column supports on a spandrel arch bridge. The element quantity is the number of columns supported by the arch.

161	Steel Hanger	Units - EA
------------	---------------------	-------------------

This element defines the hanger portion of a pin and hanger usually on a steel girder. Truss "hanger" members are not included in this element. The quantity should equal the total number of steel hangers on the bridge. Generally there will be two hangers at each location.

1. Defects are superficial and have no effect on the structural capacity of the element.
2. Number of steel columns or hangers with repairs such as: bolts or rivets have been replaced; cracks that have been drilled or plated.
3. Number of steel columns or hangers with structural defects. The defects do not significantly affect structural capacity. Deficiencies do not warrant analysis, but may require repairs. Structural deficiencies are not limited to impact damage, cracks, broken bolts, or measurable section loss due to corrosion (note the location and depth).
4. Number of steel columns or hangers with damage in significant locations or quantity and has reduced the structural capacity of the element or the bridge. Structural analysis is warranted or has determined repairs are essential to restore the full capacity of the element. Structural deficiencies are not limited to impact damage, corrosion, a crack in primary load path member or in the attachment welded to primary member. Retain the quantity of the element reported in CS4 if the element is repainted but not repaired.

This element defines a structural pin used in any connection joint in a girder or truss. The quantity should equal the total number of pins on the bridge. Zero force and construction pins are not included in the quantity. Pins in bearing elements are not included unless they have uplift loadings.

1. Number of pins and associated connection plates are in good condition.
Visual Inspection: There may be minor rust or shallow surface deformations on the exposed pin surfaces. Minor amounts of rust powder or paint damage may be present suggesting minor pin rotation in place. No pack rust is present between associated connection plates. There is no noise associated with the pin connection. **Ultrasonic Testing (UT):** Transducer can be applied to both ends of pin allowing a complete scan of pin grip surfaces, there are strong shoulder and end reflections, and there are no UT indications. **UT indications are defined as pips in the grip area that are three times larger (3:1) than the background noise when the GAIN is adjusted to produce a 90 percent - 100 percent reflection height for the far shoulder.**
2. Number of pins and associated connection plates have defects that do not affect the strength or serviceability of the bridge. **Visual Inspection:** Corrosion with pitting or laminar rust may be present. Minor abnormalities may be observed in alignment, pin wear, or deck joint movement. Pack rust may be present between connection plates, but is not judged to put a jacking force between the pin nuts. The connection may have some rust powder and/or make noise under loading. **Ultrasonic Testing (UT):** For pins UT inspected from both ends, there may be non-coincident indications between 10% and 20% of the far shoulder reflection height. There may be loss in shoulder or back reflections which can be explained by pin end conditions (dents, holes, corrosion). Pins that can be UT inspected from one end only are considered CS2, even if they have no indications or have indications less than 10 percent of the far shoulder reflection height.
3. Number of pins and associated connection plates have defects that may affect the strength or serviceability of the bridge. **Visual Inspection:** Significant corrosion may be present, suggesting that pin is “frozen” in place. Significant abnormalities may be observed in alignment, pin wear, or deck joint movement. Pack rust may be present between connection plates that place a jacking force between the pin nuts. The connection may have significant amounts of rust powder and/or make noise under loading. **Ultrasonic Testing (UT):** For pins UT inspected from both ends, there may be coincident indications (of any size) or non-coincident indications greater than 20 percent of the far shoulder reflection height. There may be loss in shoulder or back reflections that cannot be explained by pin end conditions (dents, holes, corrosion). Pins that can be UT inspected from one end only are considered CS3 if there are indications greater than 10 percent of the far shoulder reflection height.
4. Number of pins and associated connection plates have defects that are judged to affect the strength or serviceability of the bridge. **Visual Inspection:** There may be “frozen” pins designed for free rotation as part of normal bridge movement. Pack rust may be present between connection plates that are causing distortion/ displacement of plates or pins.

4.3 Substructure

Abutments

An abutment is a substructure unit located at the end of a bridge that **retains fill and typically** supports the superstructure. In BMS, the type of material used in the abutment wall defines the abutment. If the abutment has piles or columns or caps with a back wall then code the abutment type the same as back wall material type and include the quantity of piles or columns or caps with any others in the bridge.

If the abutment has integral wing walls then include their length (max. 20 feet each) in the total abutment length. If a retaining wall is being used for the abutment and the wall extends beyond the bridge then use the bridge's out to out width value plus 40 feet for the total abutment length.

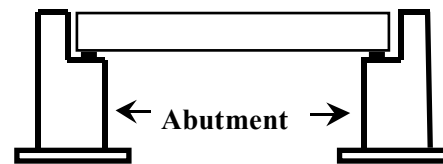
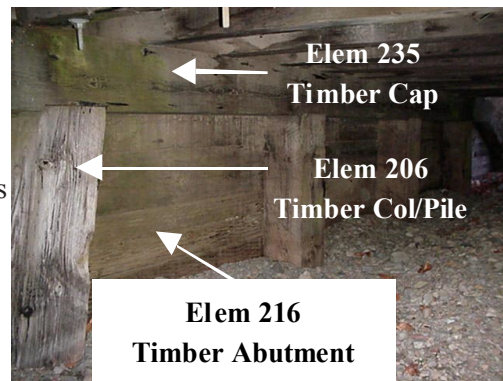

Pier Cap/Cross Beam

A pier cap is an element that is attached to the top of a pier and is used to support the superstructure of a bridge. A pier cross beam is generally attached to the girders and is used to distribute the loads from the girders to the pier.

One BMS element is used to define either a cap or cross beam constructed of the same material.



Pile Cap

A pile cap is located on top of a group of piles and provides support for columns above it. The pile cap secures the position of each of the piles in the group.

The pile cap provides a way to receive and distribute the superstructure loads into the substructure.

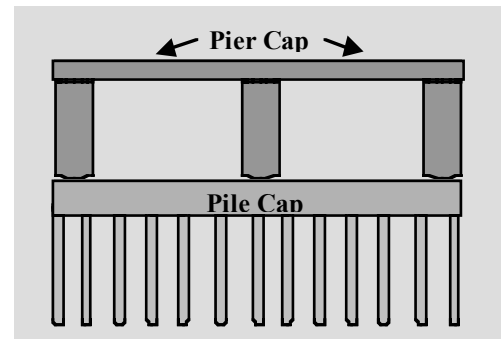

Pier Wall Definition

A pier wall is a substructure pier element.

In BMS, a pier can be defined as: a pier wall if the length (transverse direction) is **3 times greater than the width** (longitudinal direction) at the bottom; and the wall extends full height from the foundation to the superstructure. If the pier does not meet these two criteria, then the element would be coded as a column or other pier.

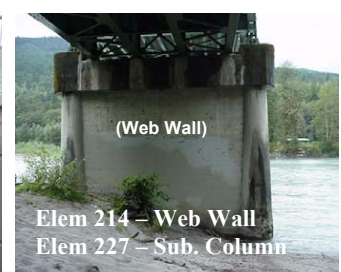
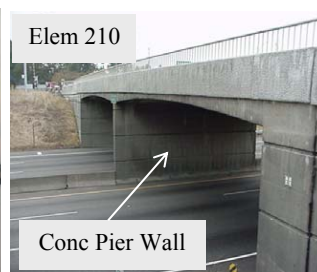
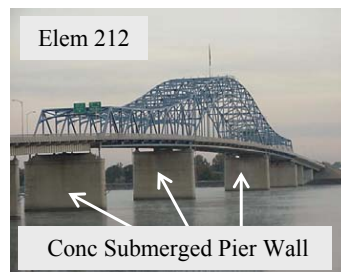
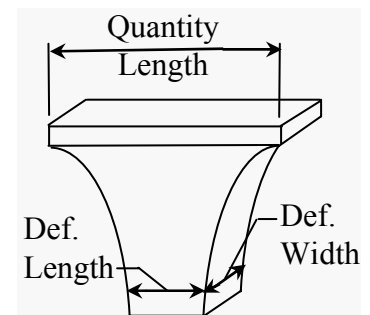

Submerged Element Definition (Pile, Column, Pier Wall, Pile Cap/Footing)

A Submerged element in BMS is defined as a substructure element located within the normal high water banks of a waterway channel. The substructure element may be only wet during high water flows. Repair or replacement of these elements may have special construction requirements as outlined in the environmental permits.

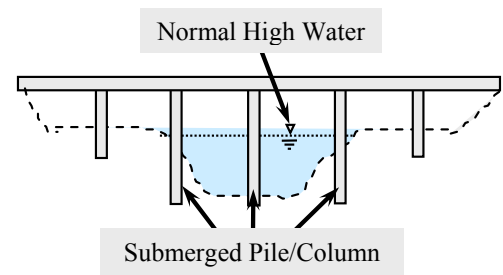

202 Steel Pile/Column **Units - EA**

This element defines a column or pile **extension** constructed of structural steel **visible for inspection**.

1. Defects are superficial and have no effect on the structural capacity of the element.
2. Number of pile/columns with repairs such as: bolts or rivets have been replaced; cracks that have been drilled or plated.
3. Number of pile/columns with structural defects. The defects do not significantly affect structural capacity. Deficiencies do not warrant analysis, but may require repairs. Structural deficiencies are not limited to impact damage, cracks, broken bolts, or measurable section loss due to corrosion (note the location and depth).
4. Number of pile/columns with damage in significant locations or quantity and has reduced the structural capacity of the element or the bridge. Structural analysis is warranted or has determined repairs are essential to restore the full capacity of the element. Structural deficiencies are not limited to impact damage, corrosion, a crack in primary load path member or in the attachment welded to primary member. Retain the quantity of the element reported in CS4 if the element is repainted but not repaired.

204 Prestressed Concrete Pile/Column **Units - EA**

This element defines a column or pile **extension** that is constructed of prestressed concrete **visible for inspection**.

205 Concrete Pile/Column **Units - EA**

This element defines a column or pile extension that is constructed of reinforced concrete **visible for inspection**. **Usually, WSDOT concrete piles are designed and constructed inside a sacrificial steel pipe.**

1. Defects are superficial and have no effect on the structural capacity of the element. There may be discoloration, efflorescence, and/or superficial cracking, spalls or delaminations.
2. Number of pile/columns that has been repaired or patched.
3. Number of pile/columns has structural defects. The defects do not significantly affect structural capacity. Deficiencies do not warrant analysis, but may require repairs. Element with defects such as: delaminations, spalls, structural cracking, exposed or corroded reinforcing or strands.
4. Number of pile/columns with damage in significant locations or quantity and has reduced the structural capacity of the element or the bridge. Structural analysis is warranted or has determined repairs are essential to restore the full capacity of the element.

206 Timber Pile/Column **Units - EA**

This element defines a column or pile **extension** constructed of timber **visible for inspection**.

1. Defects are superficial and have no effect on the structural capacity of the element. Decay, insect infestation, cracks, splits, or checks may exist.
2. Number of pile/columns with repairs, plates, or splices.
3. Number of pile/columns with structural defects. The defects do not significantly affect structural capacity. Deficiencies do not warrant analysis, but may require repairs. Typically, locations in a load path with a 1½" to 3" shell thickness are marked with a YELLOW TAG.
4. Number of pile/columns with damage in significant locations or quantity and has reduced the structural capacity of the element or the bridge. Structural analysis is warranted or has determined repairs are essential to restore the full capacity of the element. Typically, locations in a load path with less than a 1½" shell thickness are marked with a RED TAG.

207 Concrete Pile/Column w/Steel Jacket **Units - EA**

This element defines a column or pile **extension** that is constructed of reinforced concrete and has been seismically retrofitted with a steel jacket **visible for inspection**.

1. Defects are superficial and have no effect on the structural capacity of the element.
2. Number of pile/columns with repairs.
3. Number of pile/columns with structural defects. The defects do not significantly affect structural capacity. Deficiencies do not warrant analysis, but may require repairs. Structural deficiencies are not limited to impact damage, cracks, broken bolts, or measurable section loss due to corrosion (note the location and depth).
4. Number of pile/columns with damage in significant locations or quantity and has reduced the structural capacity of the element or the bridge. Structural analysis is warranted or has determined repairs are essential to restore the full capacity of the element. Structural deficiencies are not limited to impact damage, corrosion, a crack in primary load path member or in the attachment welded to primary member.

208 Concrete Pile/Column w/Composite Wrap Units - EA

This element defines a column or pile **extension** that is constructed of reinforced concrete and has been seismically retrofitted with composite wrap **visible for inspection**.

1. Defects are superficial and have no effect on the structural capacity of the element. There may be discoloration, superficial cracking or debonding.
2. Number of composite wrapped Pile/Columns with repairs.
3. Number of composite wrapped Pile/Columns with structural defects. The defects do not significantly affect structural capacity of the wrap or pile/column. Deficiencies do not warrant analysis, but may require repairs.
4. Number of composite wrapped Pile /Columns with damage in significant locations or quantity and has reduced the structural capacity of the element or the bridge. Structural analysis is warranted or has determined repairs are essential to restore the full capacity of the element.

209 Submerged Concrete Pile/Column w/Steel Jacket Units - EA

This element defines a submerged column or pile **extension** that is constructed of reinforced concrete and has been seismically retrofitted with a steel jacket **visible for inspection**.

1. Defects are superficial and have no effect on the structural capacity of the element.
2. Number of steel jacketed Pile/Columns with repairs.
3. Number of steel jacketed Pile/Columns with structural defects. The defects do not significantly affect structural capacity. Deficiencies do not warrant analysis, but may require repairs. Structural deficiencies are not limited to impact damage, cracks, broken bolts, or measurable section loss due to corrosion (note the location and depth).
4. Number of steel jacketed Pile/Columns with damage in significant locations or quantity and has reduced the structural capacity of the element or the bridge. Structural analysis is warranted or has determined repairs are essential to restore the full capacity of the element.

210 Concrete Pier Wall Units - LF

This element defines a pier wall constructed of reinforced concrete. The element quantity should equal the length at the top of the wall.

211 Other Pier Wall Units - LF

This element defines a pier wall that is constructed of a non-standard material (rock and mortar) or non-standard construction.

212 Concrete Submerged Pier Wall Units - LF

This element defines a submerged pier wall constructed of reinforced concrete. The element quantity should equal the length at the top of the wall.

213 Other Submerged Pier Wall **Units - LF**

This element defines a submerged pier wall that is constructed of a non-standard material (rock and mortar) or non-standard construction.

1. Defects are superficial and have no effect on the structural capacity of the element.
2. Length of pier wall with repairs.
3. Length of pier wall with structural defects. The defects do not significantly affect structural capacity. Deficiencies do not warrant analysis, but may require repairs.
4. Length of pier wall with damage in significant locations or quantity and has reduced the structural capacity of the element or the bridge. Structural analysis is warranted or has determined repairs are essential to restore the full capacity of the element.

214 Concrete Web Wall between Columns **Units - LF**

This element defines a secondary concrete wall constructed between pier columns. This element includes railroad crash barriers. The element quantity should equal the length at the top of the wall.

1. Defects are superficial and have no effect on the structural capacity of the element.
2. Web wall length with repairs.
3. Web wall length with structural defects. The defects do not significantly affect structural capacity. Deficiencies do not warrant analysis, but may require repairs.
4. Web wall length with damage in significant locations or quantity and has reduced the structural capacity of the element or the bridge. Structural analysis is warranted or has determined repairs are essential to restore the full capacity of the element.

215 Concrete Abutment **Units - LF**

This element defines an abutment constructed of reinforced concrete.

1. Defects are superficial and have no effect on the structural capacity of the element. There may be discoloration, efflorescence, and/or superficial cracking, spalls or delaminations.
2. Abutment length with repairs.
3. Abutment length with structural defects. The defects do not significantly affect structural capacity. Deficiencies do not warrant analysis, but may require repairs.
4. Abutment length with damage in significant locations or quantity and has reduced the structural capacity of the element or the bridge. Structural analysis is warranted or has determined repairs are essential to restore the full capacity of the element.

216	Timber Abutment	Units - LF
------------	------------------------	-------------------

This element defines an abutment constructed of timber is to include the members that retain the backfill behind the abutment. Normally, the abutment pier cap defects are recorded in the timber pier cap element 235, and the pile defects are recorded in the timber pile element 206.

1. Defects are superficial and have no effect on the structural capacity of the element. Decay, insect infestation, cracks, splits, or checks may exist.
2. Entire length of abutment if repairs exist.
3. Entire length of abutment if structural defects exist, but the defects do not significantly affect structural capacity. Deficiencies do not warrant analysis, but may require repairs. Typically, locations in a load path with a 1½" to 3" shell thickness are marked with a YELLOW TAG.
4. Entire length of abutment if damage in significant locations or quantity and has reduced the structural capacity of the abutment. Structural analysis is warranted or has determined repairs are essential to restore the full capacity of the abutment. Typically, locations in a load path with less than a 1½" shell thickness are marked with a RED TAG.

217	Other Abutment	Units - LF
------------	-----------------------	-------------------

This element defines an abutment constructed of non-standard material (rock and mortar) or non-standard construction.

1. Defects are superficial and have no effect on the structural capacity of the element.
2. Abutment length with repairs
3. Abutment length with structural defects. The defects do not significantly affect structural capacity. Deficiencies do not warrant analysis, but may require repairs.
4. Abutment length with damage in significant locations or quantity and has reduced the structural capacity of the abutment. Structural analysis is warranted or has determined repairs are essential to restore the full abutment capacity.

218 Steel Abutment

Units - LF

This element defines an abutment constructed of structural steel.

1. Defects are superficial and have no effect on the structural capacity of the element.
2. Steel span length of abutment with repairs such as: bolts or rivets have been replaced; cracks that have been drilled or plated.
3. Steel span length of abutment with structural defects. The defects do not significantly affect structural capacity. Deficiencies do not warrant analysis, but may require repairs. Structural deficiencies are not limited to impact damage, cracks, broken bolts, or measurable section loss due to corrosion (note the location and depth).
4. Steel span length of abutment affected by damage in significant locations or quantity and has reduced the structural capacity of the element or the bridge. Structural analysis is warranted or has determined repairs are essential to restore the full capacity of the element.

219 Concrete Cantilevered Span Abutment

Units - LF

This element defines an abutment for a bridge (bridge) span that is cantilevered from the first or last pier. These bridges do not have a true abutment like other bridges. The “Cantilever Span Abutment” element was created to keep this abutment type separate from the typical abutment elements. The default notation assumes the pavement seat (abutment 1) is Pier 1; the cantilever span is Span 1; the first pier is Pier 2.



1. Defects are superficial and have no effect on the structural capacity of the element. There may be discoloration, efflorescence, and/or superficial cracking, spalls or delaminations.
2. Abutment length with repairs or patched.
3. Abutment length with structural defects. The defects do not significantly affect structural capacity. Deficiencies do not warrant analysis, but may require repairs.
4. Abutment length with damage in significant locations or quantity and has reduced the structural capacity of the element or the bridge. Structural analysis is warranted or has determined repairs are essential to restore the full capacity of the element.

220	Concrete Submerged Pile Cap/Footing	Units - EA
------------	--------------------------------------------	-------------------

This element defines a reinforced concrete pile cap or footing that is visible for inspection. The pile cap or footing may be always or seasonally covered by water. The exposure may be intentional or caused by scour.

221	Concrete Pile Cap/Footing	Units - EA
------------	----------------------------------	-------------------

This element defines a reinforced concrete pile cap or footing that is visible for inspection. The exposure may be intentional or caused by erosion.

1. Defects are superficial and have no effect on the structural capacity of the element. There may be discoloration, efflorescence, and/or superficial cracking, spalls or delaminations.
2. Number of pile cap/footings with repairs.
3. Number of pile cap/footings with structural defects. The defects do not significantly affect structural capacity. Deficiencies do not warrant analysis, but may require repairs.
4. Number of pile cap/footings with damage in significant locations or quantity and has reduced the structural capacity of the element or the bridge. Structural analysis is warranted or has determined repairs are essential to restore the full capacity of the element.

222	Timber Sill/Footing	Units - LF
------------	----------------------------	-------------------

This element defines a sill, footing, or pile cap constructed of timber. This element directly supports substructure elements.

1. Defects are superficial and have no effect on the structural capacity of the element. Decay, insect infestation, cracks, splits, or checks may exist.
2. Total length of sill/footing if repairs exist.
3. Total length of sill/footing if structural defects exist, but the defects do not significantly affect structural capacity. Deficiencies do not warrant analysis, but may require repairs. Typically, locations in a load path with a 1½" to 3" shell thickness are marked with a YELLOW TAG.
4. Total length of sill/footing where damage exists in significant locations or quantity and has reduced the structural capacity of the element or the bridge. Structural analysis is warranted or has determined repairs are essential to restore the full capacity of the element. Typically, locations in a load path with less than a 1½ shell thickness are marked with a RED TAG.

225 Steel Submerged Pile/Column **Units - EA**

This element defines a pile **extension** or column that is constructed of steel and is visible for inspection. The exposure may be intentional or caused by scour.

1. Defects are superficial and have no effect on the structural capacity of the element.
2. Number of pile/columns with repairs.
3. Number of pile/columns with structural defects. The defects do not significantly affect structural capacity. Deficiencies do not warrant analysis, but may require repairs. Structural deficiencies are not limited to impact damage, cracks, broken bolts, or measurable section loss due to corrosion (note the location and depth).
4. Number of pile/columns with damage in significant locations or quantity and has reduced the structural capacity of the element or the bridge. Structural analysis is warranted or has determined repairs are essential to restore the full capacity of the element.

226 Prestressed Concrete Submerged Pile/Column **Units - EA**

This element defines a submerged pile **extension** or column that is constructed of prestressed concrete **and is visible for inspection**. The exposure may be intentional or caused by scour.

227 Concrete Submerged Pile/Column **Units - EA**

This element defines a submerged column or pile **extension** that is constructed of reinforced concrete **and is visible for inspection**. The exposure may be intentional or caused by scour.

1. Defects are superficial and have no effect on the structural capacity of the element. There may be discoloration, efflorescence, and/or superficial cracking, spalls or delaminations.
2. Number of pile/columns with repairs.
3. Number of pile/columns with structural defects. The defects do not significantly affect structural capacity. Deficiencies do not warrant analysis, but may require repairs.
4. Number of pile/columns with damage in significant locations or quantity and has reduced the structural capacity of the element or the bridge. Structural analysis is warranted or has determined repairs are essential to restore the full capacity of the element.

228	Timber Submerged Pile/Column	Units - EA
------------	-------------------------------------	-------------------

This element defines a pile or column that is constructed of timber and is visible for inspection. The exposure may be intentional or caused by scour.

1. Defects are superficial and have no effect on the structural capacity of the element. Decay, insect infestation, cracks, splits, or checks may exist.
2. Number of pile/columns with repairs, plates, or splices.
3. Number of pile/columns with structural defects. The defects do not significantly affect structural capacity. Deficiencies do not warrant analysis, but may require repairs. Typically, locations in a load path with a 1½" to 3" shell thickness are marked with a YELLOW TAG.
4. Number of pile/columns with damage in significant locations or quantity and has reduced the structural capacity of the element or the bridge. Structural analysis is warranted or has determined repairs are essential to restore the full capacity of the element. Typically, locations in a load path with less than a 1½" shell thickness are marked with a RED TAG.

231	Steel Pier Cap/Crossbeam	Units - LF
------------	---------------------------------	-------------------

This element defines a pier cap or crossbeam that is constructed of structural steel.

1. Defects are superficial and have no effect on the structural capacity of the element.
2. Steel span length of pier cap/crossbeam with repairs.
3. Steel span length of pier cap/crossbeam with structural defects. The defects do not significantly affect structural capacity. Deficiencies do not warrant analysis, but may require repairs. Structural deficiencies are not limited to impact damage, cracks, broken bolts, or measurable section loss due to corrosion (note the location and depth).
4. Steel span length of pier cap/crossbeam with damage in significant locations or quantity and has reduced the structural capacity of the element or the bridge. Structural analysis is warranted or has determined repairs are essential to restore the full capacity of the element. Structural deficiencies are not limited to impact damage, corrosion, a crack in primary load path member or in the attachment welded to primary member. Retain the quantity of the element reported in CS4 if the element is repainted but not repaired.

233 Prestressed Concrete Pier Cap/Crossbeam Units - LF

This element defines a pier cap or crossbeam that is constructed of prestressed concrete and directly supports the superstructure. This element may be attached to a submerged or non-submerged substructure element.

234 Concrete Pier Cap/Crossbeam Units - LF

This element defines a pier cap or crossbeam that is constructed of reinforced concrete and directly supports the superstructure. Integral pier caps with girders framed directly into the crossbeam are also included in element 234. This element may be attached to a submerged or non-submerged substructure element.

1. Defects are superficial and have no effect on the structural capacity of the element. There may be discoloration, efflorescence, and/or superficial cracking, spalls or delaminations.
2. Length of pier cap/crossbeam affected by repair or patch. Capacity repairs such as a strand splicing should record girder span length.
3. Length of pier cap/crossbeam affected by defects. The defects do not significantly affect structural capacity. Deficiencies do not warrant analysis, but may require repairs. Girder with defects such as: delaminations, spalls, structural cracking, exposed or corroded reinforcing or strands.
4. Length of pier cap/crossbeam affected by damage in significant locations or quantity and has reduced the structural capacity of the element or the bridge. Structural analysis is warranted or has determined repairs are essential to restore the full capacity of the element.

235 Timber Pier Cap Units - LF

This element defines a pier cap that is constructed of timber and directly supports the superstructure.

1. Defects are superficial and have no effect on the structural capacity of the element. Decay, insect infestation, cracks, splits, or checks may exist.
2. Length of pier cap with repairs, plates, or splices.
3. Length of pier cap with structural defects. The defects do not significantly affect structural capacity. Deficiencies do not warrant analysis, but may require repairs. Typically, locations in a load path with a 1½" to 3" shell thickness are marked with a YELLOW TAG.
4. Length of pier cap with damage in significant locations or quantity and has reduced the structural capacity of the element or the bridge. Structural analysis is warranted or has determined repairs are essential to restore the full capacity of the element. Typically, locations in a load path with less than a 1 ½ shell thickness are marked with a RED TAG.

4.4 Culverts

240	Metal Culvert	Units - LF
------------	----------------------	-------------------

This element defines a metal (steel, aluminum, etc.) culvert including arches, round or elliptical pipes, etc.

1. Defects are superficial and have no effect on the structural capacity of the element. There may be corrosion, erosion, scour, distortion, or roadway settlement.
2. Length of culvert with repairs.
3. Length of culvert with structural defects. The defects do not significantly affect structural capacity. Deficiencies do not warrant analysis, but may require repairs.
4. Length of culvert affected by damage in significant locations or quantity and has reduced the structural capacity of the culvert. Structural analysis is warranted or has determined repairs are essential to restore the full capacity of the element. Major deterioration, distortion, deflection, roadway settlement, or misalignment of the barrel may be in visible.

241	Concrete Culvert	Units - LF
------------	-------------------------	-------------------

This element defines all precast and cast-in-place (conventional or prestressed) concrete arch, pipe and box culverts.

1. Defects are superficial and have no effect on the structural capacity of the element. There may be discoloration, efflorescence, and/or superficial cracking, spalls or delaminations.
2. Length of culvert with repair or patch.
3. Length of culvert affected by defects. The defects do not significantly affect structural capacity. Deficiencies do not warrant analysis, but may require repairs. Girder with defects such as: delaminations, spalls, structural cracking, exposed or corroded reinforcing or strands.
4. Length of culvert affected by damage in significant locations or quantity and has reduced the structural capacity of the element or the bridge. Structural analysis is warranted or has determined repairs are essential to restore the full capacity of the culvert. Major deterioration, distortion, deflection, roadway settlement, or misalignment of the barrel may be in visible.

242 Timber Culvert **Units - LF**

This element defines all timber box culverts.

1. Defects are superficial and have no effect on the structural capacity of the element. Decay, insect infestation, cracks, splits, or checks may exist.
2. Length of culvert that has been replaced, repaired, patched, or plated.
3. Length of culvert with structural defects. The defects do not significantly affect structural capacity. Deficiencies do not warrant analysis, but may require repairs. Typically, locations in a load path with a 1½" to 3" shell thickness are marked with a YELLOW TAG.
4. Length of culvert affected by damage in significant locations or quantity and has reduced the structural capacity of the element or the bridge. Structural analysis is warranted or has determined repairs are essential to restore the structural capacity of the culvert. Major deterioration, distortion, deflection, roadway settlement, or misalignment of the barrel may be in visible. Typically, locations in a load path with less than a 1½" shell thickness are marked with a RED TAG.

243 Other Culvert **Units - LF**

This element defines all culverts not included under steel, concrete, or timber culvert elements. It may include masonry or combinations of other materials.

1. Defects are superficial and have no effect on the structural capacity of the culvert.
2. Length of culvert with repairs.
3. Length of culvert with structural defects. The defects do not significantly affect structural capacity. Deficiencies do not warrant analysis, but may require repairs.
4. Length of culvert affected by damage in significant locations or quantity and has reduced the structural capacity of the culvert. Structural analysis is warranted or has determined repairs are essential to restore the structural capacity of the culvert. Major deterioration, distortion, deflection, roadway settlement, or misalignment of the barrel may be in visible.

4.5 Tunnels

250	Tunnel – Concrete Lined	Units - SF
------------	--------------------------------	-------------------

This is an element used to identify concrete lined tunnels. Use the CoRe elements to record the elements that exist inside the tunnel.

251	Tunnel – Timber Lined	Units - SF
------------	------------------------------	-------------------

This is an element used to identify timber-lined tunnels. Use the CoRe elements to record the elements that exist inside the tunnel.

252	Tunnel – Unlined	Units - SF
------------	-------------------------	-------------------

This is an element to identify unlined tunnels. Use the CoRe elements to record the elements that exist inside the tunnel.

1. Defects are superficial and have no effect on the structural capacity of the tunnel.
2. Tunnel area with repairs or patches.
3. Tunnel area with structural defects. The defects do not significantly affect structural capacity. Deficiencies do not warrant analysis, but may require repairs.
4. Tunnel area affected by damage in significant locations or quantity and has reduced the structural capacity of the tunnel (or tunnel liner). Structural analysis is warranted or has determined repairs are essential to restore the full capacity of the element.

253	Tunnel Tile	Units - SF
------------	--------------------	-------------------

This is an element to identify tunnel tile.

1. Tile is bonded with no cracks, chips, or blemishes. Tile may be dirty but reflectivity is enhanced during regular tunnel washing operations.
2. Tile area that has been repaired.
3. Tile area that is bonded, but cracked and may have efflorescence or small amounts of section loss. Tile may be blemished from impact or other causes resulting in major loss of reflectivity.
4. Tile area with delaminations based on soundings, is completely missing, or has major section loss warranting replacement.

4.6 Sidewalk and Supports

A sidewalk is an element that provides pedestrian access across a bridge. A sidewalk is supported by a bridge deck and/or by sidewalk brackets that consist of several types of materials. The purpose of the sidewalk BMS is to record the structural integrity of the support system and sidewalk. Identify these elements in BMS if the sidewalk width is greater than or equal to 3 feet.

However, there are exceptions that must be accommodated. When there is a true sidewalk on a bridge as determined by the design, approach sidewalks, and location, it is appropriate to enter a sidewalk element in the BMS. Timber sidewalks, for example, may be narrow and have a support system. These exceptions should include a sidewalk BMS element. Please make a specific note explaining the reasoning for including the sidewalk element.

If a rail retrofit or a wide curb has been determined to NOT be a sidewalk, then Bridge Rail elements will be used to document defects.



260	Steel Open Grid Sidewalk and Supports	Units - SF
------------	----------------------------------------------	-------------------

This element defines a sidewalk constructed of steel grids that are open and unfilled. This element also includes the members used to provide support like stringers and braces. The total quantity should equal the width of the sidewalk times its length.

261	Steel Concrete Filled Grid Sidewalk and Supports	Units - SF
------------	---------------------------------------------------------	-------------------

This element defines a sidewalk constructed of steel grids that have been filled with concrete. This element also includes the members used to provide support like stringers and braces. The total quantity should equal the width of the sidewalk times its length.

262	Corrugated/Orthotropic Sidewalk and Supports	Units - SF
------------	-----------------------------------------------------	-------------------

This element defines a sidewalk constructed of corrugated metal filled with Portland cement concrete or asphaltic concrete or an orthotropic steel deck. This element also includes the members used to provide support like stringers and braces. The total quantity should equal the width of the sidewalk times its length.

264 Timber Sidewalk and Supports **Units - SF**

This element defines a sidewalk constructed of timber. This element also includes the members used to provide support like stringers and braces. The total quantity should equal the width of the sidewalk times its length.

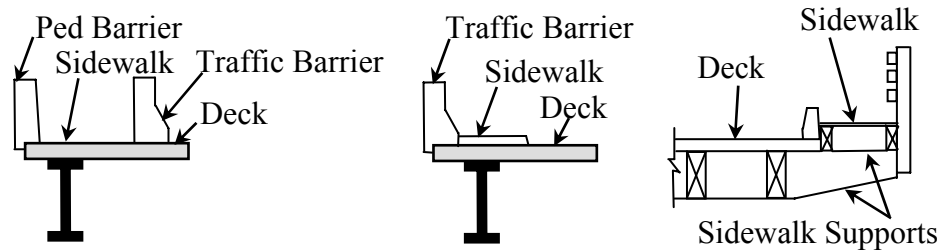

266 Concrete Sidewalk and Supports **Units - SF**

This element defines a sidewalk constructed of reinforced concrete. The concrete sidewalk may be supported by the roadway deck, bracing, diaphragms, or sidewalk stringers. The total quantity should equal the width of the sidewalk times its length.

267 Fiber Reinforced Polymer (FRP) Sidewalk and Supports **Units - SF**

This element defines a sidewalk constructed of fiber-reinforced polymer. This element also includes the members used to provide support like stringers and braces. The total quantity should equal the width of the sidewalk times its length.

1. Defects are superficial and have no effect on the structural capacity of the sidewalk or supports.
2. Sidewalk area (or support projected area) with repairs or patches
3. Sidewalk area (or support projected area) with structural defects. The defects do not significantly affect structural capacity. Deficiencies do not warrant analysis, but may require repairs.
4. Sidewalk area (or support projected area) affected by damage in significant locations or quantity and has reduced the structural capacity of the sidewalk support. Structural analysis is warranted or has determined repairs are essential to restore the full capacity of the element.

4.7 Bearings

When an in-span hinge separates two structures, the joint, bearing, and seismic restrainers at the hinge will be documented in the dependant (or supported) structure only.

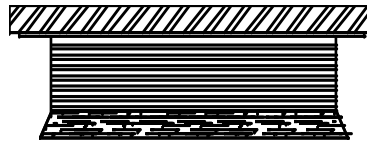

310 Elastomeric Bearing

Units - EA

This element defines a bridge bearing that is constructed primarily of elastomers, with or without fabric or metal reinforcement.



311 Moveable Bearing (Roller, Sliding, etc.)

Units - EA

This element defines those bridge bearings that provide for both deflection and longitudinal movement by means of roller, rocker or sliding mechanisms.

312 Concealed Bearing or Bearing System

Units - EA

This element defines those bridge bearings and/or bearing seats that are accessible with tools or equipment and therefore are not open for detailed inspection.



313 Fixed Bearing **Units - EA**

This element defines those bridge bearings that provide for rotation only.

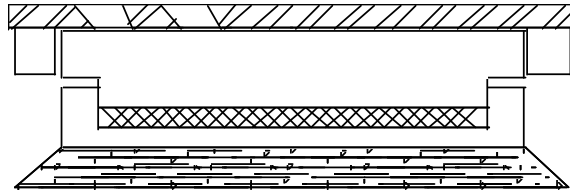

314 Pot Bearing **Units - EA**

This element defines those high load bearings with a confined elastomer. The bearing may be fixed against horizontal movement, guided to allow sliding in one direction, or floating to allow sliding in any direction.

315 Disc Bearing **Units - EA**

This element defines a high load bearing with a hard plastic disc. The bearing may be fixed against horizontal movement, guided to allow sliding in one direction, or floating to allow sliding in any direction.

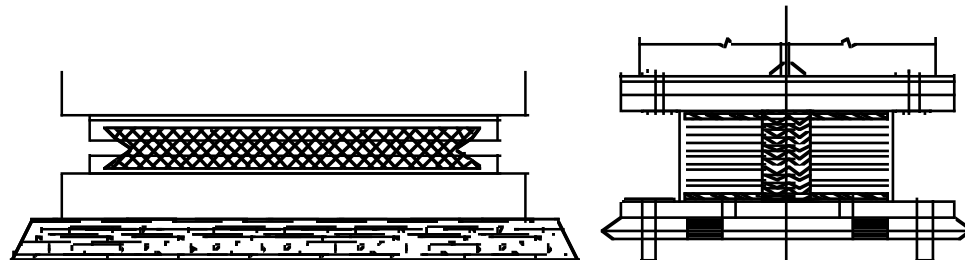

316 Isolation Bearing **Units - EA**

This element defines a bearing that is laminated and is a sandwich of neoprene and steel plates. The bearing contains a lead core that is primarily used for seismic loads. The isolation bearing is used to protect structures against earthquake damage.

1. Defects are superficial and have no effect on the superstructure movements or safe transfer of load to the substructure. Shear deformation, displacement, or cracking of grout pad may be present. Top and bottom surfaces may not be parallel.
2. **Number of bearings with a repair**
3. Number of bearings with structural defects. The defects are not detrimental to the superstructure or the safe transfer of load to the substructure. Deficiencies do not warrant analysis, but may require repairs.
4. Number of bearings with defects that are detrimental to the superstructure or the safe transfer of load to the substructure. Loss of minimum bearing area may be imminent. Structural analysis is warranted or has determined bearing repairs are essential to restore the safe movement or transfer of load to the substructure.

321 Concrete Roadway Approach Slab

Units - SF

This element defines a structural concrete slab supported at the bridge abutment and the roadway pavement. This element is essentially a concrete deck element that documents the surface conditions of the approach slab. The element quantity is the total area of both concrete approach slabs attached to the bridge. Do not include asphalt shoulder if present.

1. Defects are superficial. The slab surface do not have spalls/delaminations or previous repairs. The deck surfaces may have cracks or rock pockets. Wear and rutting may expose aggregate or reinforcing.
2. Slab area with repairs or patches. Do not include the rare case rutting filled with patching material.
3. Slab area with spalling.
4. If the results of delamination testing on the approach slab are available, record the delaminated area CS4.

322 Roadway Profile

Units - EA

This element flags a problem with the roadway profile from the pavement seat to a maximum distance of 50 feet away from a structure. The approaching roadway profile should be a smooth transition for cars and trucks on or off the structure. Vehicles should remain steady and not rock from side to side or up and down. Oil staining on the road is a good indicator there may be a problem. Notes should describe the nature of the problem or the solution, if one can be identified. Total quantity is the number of roadway profiles on and off of the bridge. Head to head traffic has two and traffic divided by a median would generally have four. Code the number of profiles in the condition state that best indicates the severity of the problem.

1. The roadway profile grade is smooth even though wheel bouncing may exist from small patches, potholes, or rutted edges.
2. Paving operations have repaired the grade with tapered asphalt patching that may or may not extend on to the approach slab or bridge deck.
3. The roadway profile grade has less than 1 inch height change over a distance of 40 feet. Minor movement of the vehicles may exist and there is not a significant increase in load to the structure.
4. The roadway profile grade has more than 1 inch height change over a distance of 40 feet. The profile deviation is noticeable to vehicles and there may be an increase in load to the structure.

4.8 Bridge Rail

Bridge rail BMS elements are to be entered for each type of rail. For example, if there is W-beam or Thrie beam guardrail mounted on the concrete bridge rail, then the length of each metal and concrete element should be entered. If the original concrete bridge rail has aluminum rail installed on top (with or without a rail retrofit), enter that quantity into the appropriate BMS element as well. In the element notes, describe what type of metal bridge or pedestrian rail has been entered.

330	Metal Bridge Railing	Units - LF
------------	-----------------------------	-------------------

This element defines all types and shapes of metal bridge railing aluminum, metal beam, rolled shapes, etc. The quantity should equal the total length measured along each bridge rail.

331	Concrete Bridge Railing	Units - LF
------------	--------------------------------	-------------------

This element defines all types and shapes of reinforced concrete bridge railing. The quantity should equal the total length measured along each bridge rail.

332	Timber Bridge Railing	Units - LF
------------	------------------------------	-------------------

This element defines all types and shapes of timber railing. All elements of this rail (except connectors) must be timber. The quantity should equal the total length measured along each bridge rail.

333	Other Bridge Railing	Units - LF
------------	-----------------------------	-------------------

This element defines all types and shapes of bridge railing except those defined as METAL, CONCRETE or TIMBER. This element will include cable rails, and combinations of materials. The quantity should equal the total length measured along each bridge rail.

1. Defects are superficial and have no effect on the structural capacity of the element.
2. **Bridge rail length with a repair.**
3. Bridge rail length with structural defects. The defects do not significantly affect structural capacity. Deficiencies do not warrant analysis, but may require repairs. Structural deficiencies are not limited to impact damage, cracks, broken bolts, or measurable section loss due to corrosion (note the location and depth), decay, or spalling.
4. Bridge rail length with damage in significant locations or quantity and has reduced the structural capacity of the rail. Structural analysis is warranted or has determined repairs are essential to restore the full capacity of the element.

4.9 Pedestrian Rail

A pedestrian rail will typically be on the outside of a sidewalk and protected from traffic by a Bridge Rail.

340	Metal Pedestrian Rail	Units - LF
------------	------------------------------	-------------------

This element defines all types and shapes of metal pedestrian bridge railing including steel (excluding weathering steel), aluminum, metal beam, rolled shapes, etc. The quantity should equal the total length measured along each pedestrian rail.

341	Concrete Pedestrian Rail	Units - LF
------------	---------------------------------	-------------------

This element defines all types and shapes of reinforced concrete pedestrian bridge railing. The quantity should equal the total length measured along each pedestrian rail.

342	Timber Pedestrian Rail	Units - LF
------------	-------------------------------	-------------------

This element defines all types and shapes of timber pedestrian bridge railing. All elements of this rail (except connectors) must be timber. The quantity should equal the total length measured along each pedestrian rail.

343	Other Pedestrian Rail	Units - LF
------------	------------------------------	-------------------

This element defines all types and shapes of pedestrian bridge railing except those defined as METAL, CONCRETE or TIMBER. This element will include cable rails, and combinations of materials. The quantity should equal the total length measured along each pedestrian rail.

1. Defects are superficial and have no effect on the structural capacity of the element.
2. Pedestrian rail length with a repair.
3. Pedestrian rail length with structural defects. The defects do not significantly affect structural capacity. Deficiencies do not warrant analysis, but may require repairs. Structural deficiencies are not limited to impact damage, cracks, broken bolts, or measurable section loss due to corrosion (note the location and depth), decay, or spalling.
4. Pedestrian rail length with damage in significant locations or quantity and has reduced the structural capacity of the rail. Structural analysis is warranted or has determined repairs are essential to restore the full capacity of the element.

4.10 Smart Flags

355 Damaged Bolts or Rivets **Units - EA**

This smart flag is used to identify superstructure steel elements that have broken or missing bolts and/or rivets. Report one unit for each occurrence in the corresponding condition state.

1. Number of damaged (or missing) bolt or rivet in secondary member(s).
2. Number of damaged (or missing) bolt or rivet has been replaced.
3. Number of damaged (or missing) bolt or rivet in a primary member(s).

356 Steel Cracking **Units - EA**

This smart flag is used to identify superstructure steel elements with cracks. Report one unit for each occurrence (or crack) in the corresponding condition state. If fatigue damage exists, which may warrant analysis of the element or the serviceability of the element is uncertain, contact a BPO supervisor immediately.

1. Number of steel cracks, of any length, in a secondary member(s).
2. Number of steel cracks within a load path that have been repaired or arrested. The bridge may still be prone to fatigue.
3. Number of steel cracks within a load path that are not arrested and less than 1 inch. Any cracks (typically cope cracks) must be repaired according to BPO specified procedures.
4. Number of steel cracks within a load path that are not arrested and 1 inch or greater in length. Any cracks (typically cope cracks) must be repaired according to BPO specified procedures.

357 Pack Rust **Units - EA**

The primary purpose of this smart flag is to quantify steel connections where rust expansion is visually deflecting steel plates and should be addressed when the bridge is painted. Structural impacts to rust pack overstressing are recorded in the steel elements. The total quantity is the number of existing pack rust locations identified by the inspector.

1. **Approximate** number of locations where visible pack rust exists and is less than ¼ inch thick.
2. Number of locations where pack rust is more than ¼ inch thick.

360 Bridge Movement**Units - EA**

The primary purpose of this smart flag is to identify structural movement that is causing significant distress to the bridge. Movements may be horizontal, vertical, or rotational. Evidence of movement should be documented (photo) in such a way that future measurements can determine if the structure is still moving or has stabilized.

1. The entire bridge appears to have stabilized due to repairs or recent history of measurements. Tilt meters, piezometer tubes, or monitoring system show no movement in the past two years.
2. Bridge elements are moving but do not cause a significant problem for the bridge. Bearings may be approaching design limits. Substructure elements may be moving.
3. Bridge movement is at or beyond design limits. Investigation and repair analysis of the bridge is warranted.

361 Scour**Units - EA**

This smart flag is used to identify foundation scour for bridges crossing waterways as observed during inspections. Its primary purpose is to identify bridge piers or abutments that are experiencing scour and to provide some measure of the magnitude of that scour.

1. Number of pier/abutment foundations where no Scour exists, or the scour has been repaired and is functioning as designed.
2. Number of pier/abutment foundations where scour is superficial and has no effect on the foundation structural capacity. No exposed spread footings. Minimum pile embedment is greater than 10'. The substructure code is not affected by scour. Monitor scour condition.
3. Number of pier/abutment foundations where scour exists. The scour does not significantly affect the foundation structural capacity. Scour does not warrant analysis, but may require repairs. If left unchecked, could adversely impact the foundation structural capacity. Top of spread footings may be exposed. Minimum pile embedment is between 5' and 10'. The NBI substructure code (676) of 4 (poor condition) would be appropriate if the scour had undermined the foundation to the point the load carrying capacity of the pier or abutment had been reduced, or it was potentially unstable. Reanalysis of the scour code may be warranted. Repairs to the bridge may be warranted.
4. Number of pier/abutment foundations with scour damage in significant locations or quantity and has reduced the foundation structural capacity. Structural analysis is warranted or has determined repairs are essential to restore the full capacity of the pier. Undermining of spread footings or foundation material is occurring. Minimum pile embedment is less than 5'. NBI scour code should be coded 2 or less. If local failure of the foundation or substructure element were possible, NBI substructure code should be a 3 (serious condition). Directly comment that the substructure rating is based on the pile embedment length. Evaluate and comment on any riprap or other scour countermeasures that are in place. Make a recommendation to evaluate the pile for lateral stability. Document the scour condition thoroughly. Repairs to the bridge are necessary.

362 Impact Damage **Units - EA**

This is a smart flag used to identify damage caused by impact from traffic or other causes such as flood debris. A maximum of 1 unit can be coded in each condition state.

1. Impact damage has occurred. None of the prestressed system is exposed. Repair, patching, or heat straightening is not required.
2. Impact damage has been repaired or patched. Any damage to a prestressed system has been repaired and patched. Steel elements have been repaired and painted.
3. Impact damage has occurred. Any prestressed system exposure is due to a traffic impact, but is not impaired. Patching concrete or heat straightening of steel is needed.
4. Impact damage has occurred and strength of the member is impaired. Analysis is warranted to ascertain if the member can be repaired or needs to be replaced.

366 Undercrossing – Safety Inspection **Units - EA**

This is a smart flag for safety checks of Railroad and other non-vehicular undercrossings. No other core elements are needed.

1. Report the entire bridge in condition state one (EA).

367 Movable Bridge **Units - EA**

This is a smart flag to identify movable bridges. BMS elements will be used in addition to this smart flag.

1. A Movable bridge with elements that do not require repair (EA).
2. A Movable bridge with elements that require repair (EA).

368 Seismic Pier Crossbeam Bolster **Units - EA**

This element identifies concrete piers with seismic structural improvements.

1. Number of piers with a crossbeam bolster.



369 Seismic Pier Infill Wall **Units - EA**

This element identifies concrete piers with seismic structural improvements.

1. Number of piers with a seismic pier infill wall.



4.11 Seismic Restrainers

Earthquake restrainers have been installed on WSDOT bridges since the 1980's. The typical longitudinal restrainer uses epoxy coated Dywidag bars with a designed gap maintained by double nuts. An earlier system using springs to maintain the required restrainer gap was used until the early 1990's when it was discontinued as being ineffective. Gap measurements are required during an inspection if visual inspection or loose double nuts indicate the gaps are not uniform.



370	Seismic – Longitudinal Restrainer	Units - EA
------------	------------------------------------------	-------------------

This element is used to identify longitudinal seismic restrainers. When an in-span hinge separates two structures, the joint, bearing, and seismic restrainers at the hinge will be documented in the dependant (or supported) structure only. The quantity should equal the total number of longitudinal restrainers on the bridge.

371	Seismic – Transverse Restrainer	Units - EA
------------	----------------------------------------	-------------------

This element is used to identify transverse seismic restrainers. When an in-span hinge separates two structures, the joint, bearing, and seismic restrainers at the hinge will be documented in the dependant (or supported) structure only. The quantity should equal the total number of transverse restrainers on the bridge.

372	Seismic – Link/Pin Restrainer	Units - EA
------------	--------------------------------------	-------------------

This element is used to identify link/pin seismic restrainers. When an in-span hinge separates two structures, the joint, bearing, and seismic restrainers at the hinge will be documented in the dependant (or supported) structure only. The quantity should equal the total number of link/pin restrainers on the bridge.

1. Restrainer is in good condition and will function as designed. Anchor plate nuts have been checked and are in good condition.
2. Number of restrainers with misaligned seismic-longitudinal restrainer rods. Anchor plate nuts that are tight, but that have epoxy running down their bolts or are of varying lengths. The gap between adjacent longitudinal restrainers varies between ¼ inch and ¾ inch. Short transverse pipe restrainer length. Measure the depth of the diaphragm hole to the restrainer. Take a picture of the hole and tape measure.
3. Number of restrainers with improper anchor plate installation. Loose or inadequately bonded anchor nuts. A repair is warranted if over 25% of the anchor nuts have more than 2 inches of bolt thread exposed below the nut. Restrainer gap variation in a series of longitudinal seismic restrainers is greater than ¾ inches (measure and add the two gap distances on both sides of each restrainer in making your comparisons). Loose double nuts. Specify the replacement of the double nuts with (new) nuts having (with) setscrews and the resetting of the restrainer gaps according to the design tables. The inspector shall specify the required gaps, according to the bridge plans, in the repair.



373 Seismic – Catcher Block Units - EA

This element is used to identify a catcher block attached to a pier or abutment installed as part of a seismic retrofit. The quantity should equal the total number of catcher blocks on the bridge.

1. Number of catcher blocks in good condition.
2. Number of catcher blocks with deficiencies that need correction.

375 Cathodic Protection Units - EA

This is a smart flag used to identify a cathodic protection system used on a bridge. The quantity should equal the total number of cathodic protection systems on the bridge.

1. Code 1 if the cathodic protection system is functioning as designed.
2. Code 1 if the cathodic system is no longer functioning as designed.

376 Concrete Deck Delamination Testing Units - SF

This is a smart flag used to identify the results of concrete deck delamination testing. For Washington State bridges, the BMS engineer will provide the area of condition states and 376 notes for this element.

1. Deck area with no delaminations
2. For bridges with an ACP overlay, this is the area of concrete patching before an overlay was constructed. No action required by the inspector.
3. Deck area with concrete spalling measured in the Materials Lab Deck Delamination Test.
4. Deck area with concrete delamination measured in a Materials Lab Deck Delamination Test. This area should be recorded in the Concrete Deck CS4 (or Deck and Concrete Overlay CS4).

380 Unknown Pier Foundations Units - EA

This smart flag is used to identify the number of submerged unknown pier foundations on a bridge. The unknown status is based on nonexistent foundation plans for the pier. This is information only and no action is required of the inspector for this Smart Flag.

1. The number of submerged unknown pier foundations.

4.12 Expansion Joint BMS

The expansion joint condition states are designed to track the criteria associated with joint structural failure such as spalling, patches, and other structural problems. A spall within 1' - 0" of a joint system should be considered a joint spall and not included with the deck spalling. Spalls next to the joint are a joint deficiency rather than deck deterioration.

Missing or defective joint glands are not considered structural joint failures in the joint condition states. Some joints are designed to pass water and many joints leak within days of installation. If the joint seal leakage is causing structural problems with elements below the joint, this should be noted in the report and a repair should be recommended. A smart flag or element may be used to track this deterioration in the future, but it is not included in the joint condition states at this time.

If any portion of a joint falls into a lower condition state, code the entire length of the joint in the lower condition state. Joints with structural defects are coded in CS2. Joints that require replacement are tracked in CS3. In general, joints in Condition State 3 will be programmed for rehabilitation or replacement.

When the entire joint is replaced with a new joint system, change the BMS element to the new joint type. Do not use more than one BMS element for a joint location, unless the structure has been widened and there are two joint systems present. Joint notes should reference specific joints by pier or span number.

When an in-span hinge separates two structures, the joint, bearing, and seismic restrainers at the hinge will be documented in the dependant (or supported) structure only.

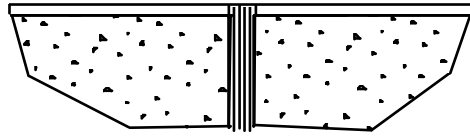

402 Hot Poured and/or Premolded Joint Filler

Units - LF

This element defines a joint in the concrete deck that has been filled with a poured rubber or hot applied asphalt or has been constructed with premolded joint filler. Use this element as default for open joints. The quantity should equal the length measured along the expansion joint.

1. The expansion joint is functioning as designed. Joint may not be perfect with signs of leakage. The adjacent deck or header is sound.
2. Skewed joint length at each location with “D” spalls or patches are present in the header or in the deck within one foot of either side of the joint.
3. Skewed joint length at each location where the deck or headers must be rebuilt to maintain a reliable roadway surface. As a guideline, more than 25 percent of the joint length has spalls or patches in the deck or headers adjacent to the seal.

For truss bridges, joint length at each floorbeam should be coded CS3 where water is corroding the top flange and/or connections. A repair to reseal the joints is required.



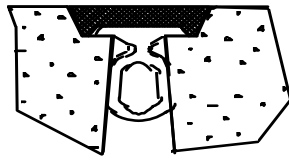

403 – Poured Rubber and Bulb-T

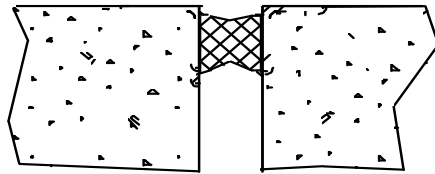

404 – Compression Seal/Concrete Header

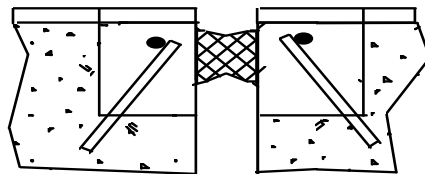

405 – Compression Seal/Polymer Header

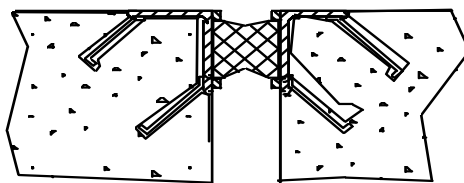

406 – Compression Seal/Steel Header

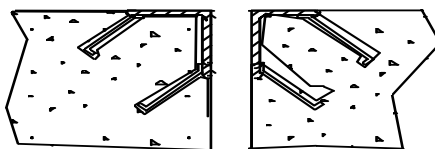

407 – Steel Angle Header



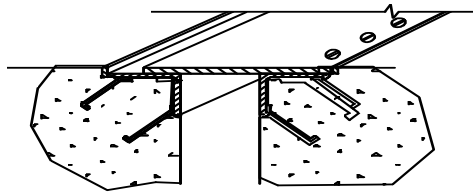

408 – Steel Sliding Plate

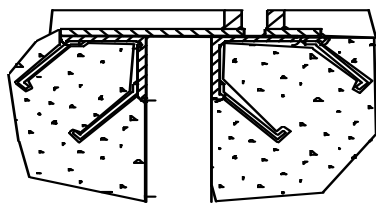

409 – Steel Sliding Plate w/Raised Bars

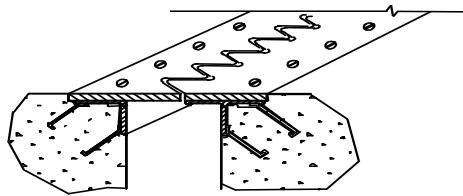

410 – Steel Fingers

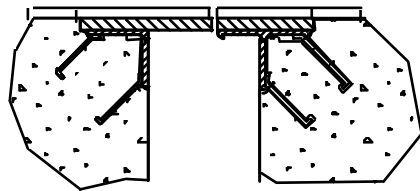

411 – Steel Fingers w/Raised Bars

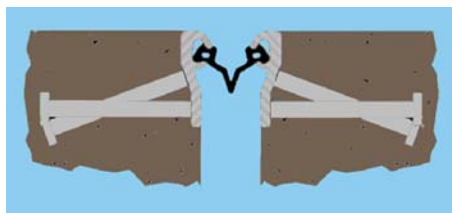

412 – Strip Seal-Anchored

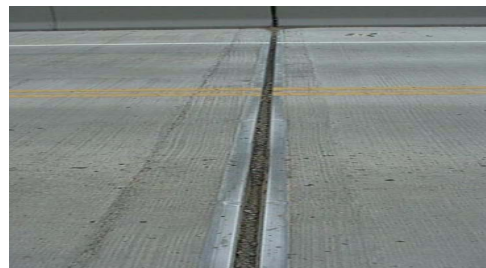

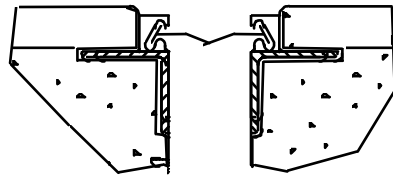

413 – Strip Seal-Welded

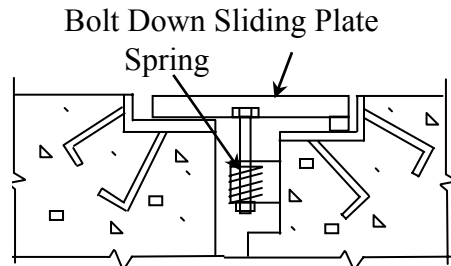

414 – Bolt Down Sliding Plate with Springs

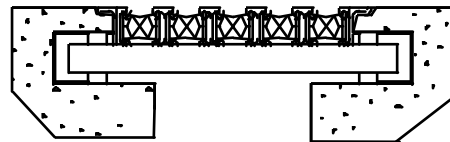

416 – Assembly Joint Seal (Modular)

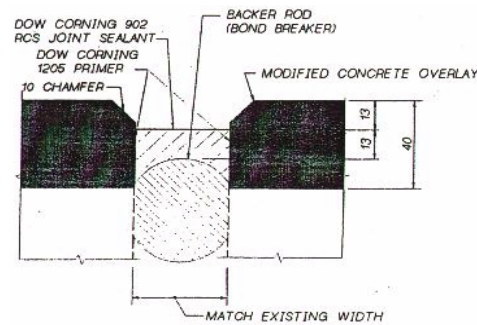

417 – Silicone Rubber Joint Filler

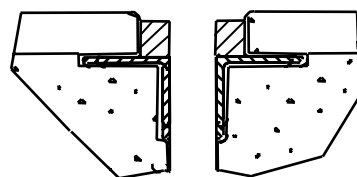

419 – Steel Angle w/Raised Bars



403	Poured Rubber and Bulb-T	Units - LF
<p>This element defines a joint filled with a pourable sealant and a Bulb-T preformed seal. The quantity should equal the length measured along the expansion joint.</p>		
404	Compression Seal/Concrete Header	Units - LF
<p>This element defines a joint with concrete headers formed during the original construction of the bridge. The joint is filled with a pre-formed compression type seal. The quantity should equal the length measured along the expansion joint.</p>		
405	Compression Seal/Polymer Header	Units - LF
<p>This element defines those joints that have been rehabilitated with a polymer header and filled with a pre-formed compression type seal. The quantity should equal the length measured along the expansion joint.</p>		
406	Compression Seal/Steel Header	Units - LF
<p>This element defines a joint with steel angle plate headers that have a pre-formed compression type seal. The quantity should equal the length measured along the expansion joint.</p>		
407	Steel Angle Header	Units - LF
<p>This element defines an open joint with steel angle plate headers. The quantity should equal the length measured along the expansion joint.</p>		
408	Steel Sliding Plate	Units - LF
<p>This element defines a joint with steel sliding plates. The quantity should equal the length measured along the expansion joint.</p>		
409	Steel Sliding Plate w/Raised Bars	Units - LF
<p>This element defines a joint with steel sliding plates and steel raised bars welded to the plates to accommodate an overlay. The quantity should equal the length measured along the expansion joint.</p>		
410	Steel Fingers	Units - LF
<p>This element defines a joint with open steel fingers. The quantity should equal the length measured along the expansion joint.</p>		
411	Steel Fingers w/Raised Bars	Units - LF
<p>This element defines a joint with bars or plates welded to the steel finger plates to accommodate an overlay. The quantity should equal the length measured along the expansion joint.</p>		
412	Strip Seal – Anchored	Units - LF
<p>This element defines an expansion joint that uses a neoprene type waterproof gland with steel extrusion or other system to anchor the gland. The steel extrusion is anchored into the concrete deck or header. The quantity should equal the length measured along the expansion joint..</p>		

413 Strip Seal – Welded **Units - LF**

This element defines an expansion joint that uses a neoprene type waterproof gland with steel extrusion or other system to anchor the gland. The steel extrusion is welded to a pre existing steel expansion joint. The quantity should equal the length measured along the expansion joint.

414 Bolt Down - Sliding Plate w/springs **Units - LF**

This element defines a bolted sliding plate expansion joint that uses steel springs. The quantity should equal the length measured along the expansion joint.

1. The expansion joint is functioning as designed. Joint may not be perfect with signs of leakage. The adjacent deck or header is sound.
2. Skewed joint length at each location with “D” spalls or patches present in the header or in the deck within one foot either side of the joint.
3. Skewed joint length at each location where the deck or headers must be rebuilt to maintain a reliable roadway surface or to maintain seal placement. As a guideline, more than 25 percent of the joint length has spalls or patches in the deck or headers adjacent to the seal.

Steel Materials: Steel components are banging, cracked, loose, broken, or missing. Steel sections that have been removed and/or replaced with something else (usually concrete patching) should be CS3.

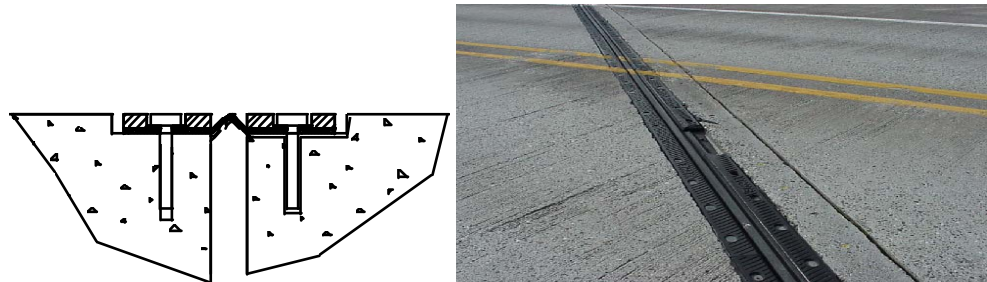

415 Bolt Down Panel – Molded Rubber **Units - LF**

This element defines an expansion joint that uses a waterproof gland that is held in place by molded rubber panels that are attached with bolts. The quantity should equal the length measured along the expansion joint.

1. The expansion joint is functioning as designed. Joint may not be perfect with signs of leakage. The adjacent deck or header is sound. Molded Rubber panels are secure and have no defects.
2. Skewed joint length at each location with “D” spalls or patches present in the header or in the deck within one foot either side of the joint. Some of the bolts may be broken but they represent less than 10 percent of the total for that panel.
3. Skewed joint length at each location where more than 10 percent of the bolts in a panel are missing, loose, or broken. As a guideline, more than 25 percent of the joint length has spalls or patches in the deck or headers adjacent to the seal

416 Assembly Joint Seal (Modular) Units - LF

This element defines a large movement joint that has an assembly mechanism with multiple neoprene type waterproof glands. The quantity should equal the length measured along the expansion joint.

417 Silicone Rubber Joint Filler Units - LF

This element defines an expansion joint that has been repaired with a single or two component rubber joint filler. The quantity should equal the length measured along the expansion joint.

1. The expansion joint is functioning as designed. Joint may not be perfect with signs of leakage. The adjacent deck or header is sound.
2. Skewed joint length at each location with “D” spalls or patches present in the header or in the deck within one foot either side of the joint.
3. Skewed joint length at each location where the deck or headers must be rebuilt to maintain a reliable roadway surface or to maintain seal placement. As a guideline, more than 25 percent of the joint length has spalls or patches in the deck or headers adjacent to the seal.

Steel Materials: Steel components are banging, cracked, loose, broken, or missing. Steel sections that have been removed and/or replaced with something else (usually concrete patching) should be CS3.

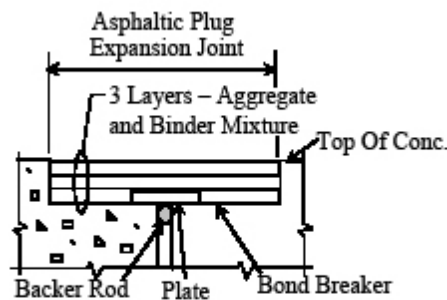

418 Asphalt Plug Units - LF

This element defines an expansion joint that has been replaced with an asphalt plug system. The quantity should equal the length measured along the expansion joint.

1. The expansion joint is functioning as designed. Joint may not be perfect with signs of leakage. The adjacent deck or header is sound.
2. Skewed joint length at each location with rutting in the joint is minor. “D” spalls or patches are present in the joint, or in deck adjacent to joint.
3. Skewed joint length at each location where the asphalt material in the joint has significant rutting, bulging or is missing. As a guideline, more than 25 percent of the joint length has spalls or patches in the deck or headers adjacent to the seal.

419 Steel Angle w/Raised Bars **Units - LF**

This element defines a joint with steel angles and steel raised bars welded to the angles to accommodate an overlay. The quantity should equal the length measured along the expansion joint.

1. The expansion joint is functioning as designed. Joint may not be perfect with signs of leakage. The adjacent deck or header is sound.
2. Skewed joint length at each location with “D” spalls or patches present in the header or in the deck within one foot either side of the joint.
3. Skewed joint length at each location where the deck or headers must be rebuilt to maintain a reliable roadway surface or to maintain seal placement. As a guideline, more than 25 percent of the joint length has spalls or patches in the deck or headers adjacent to the seal.

Steel Materials: Steel components are banging, cracked, loose, broken, or missing. Steel sections that have been removed and/or replaced with something else (usually concrete patching) should be CS3.

420 Joint Paved Over Flag **Units - LF**

This element typically identifies steel joint systems that have been paved over with an HMA overlay and is causing a problem. When this flag is used, a cost for joint work will be included in the next paving contract to correct the problem. Since the joint can not be inspected, the joint element condition states should remain unchanged (and so noted). The Total quantity will be the sum total length of all joint systems on the bridge.

1. Skewed joint length at each location that is paved over, but rehabilitation is not required.
2. Skewed joint length at each location that requires rehabilitation. A photo is helpful to determine the type of rehabilitation.

4.13 Movable Bridges

501	Movable Bridge Steel Tower	Units - LF
<p>This element defines the structural steel columns and members used to support a counter weight of a vertical lift span. The total quantity is the total of the supporting column lengths.</p>		
<ol style="list-style-type: none"> 1. Defects are superficial and have no effect on the structural capacity of the element. 2. Tower column length with repairs such as: bolts or rivets have been replaced; cracks that have been drilled or plated. 3. Tower column length with structural defects. The defects do not significantly affect structural capacity. Deficiencies do not warrant analysis, but may require repairs. 4. Tower column length affected by damage in significant locations or quantity and has reduced the structural capacity of the column or the tower. Structural analysis is warranted or has determined repairs are essential to restore the full capacity of the element. Structural deficiencies are not limited to impact damage, corrosion, a crack in primary load path member or in the attachment welded to primary member. Retain the quantity of the element reported in CS4 if the element is repainted but not repaired. 		

4.14 Other Bridge Elements

705	Bridge Luminaire Pole and Base	Units - EA
<p>This element is defined by a light pole and anchor system attached to a bridge. It does not include the mast arm or other types of lights that may be attached to the bridge. The condition states describe the structural condition of the pole, anchor bolts, and support. Region maintenance may need to be contacted prior to inspection in order to remove bolt covers or otherwise provide access for inspection. The total element quantity should equal the number of luminaire poles attached to the bridge.</p>		
<ol style="list-style-type: none"> 1. There are no significant structural defects in the pole or support, and the grout pad is solid. Poles or supports that have been replaced are coded in this condition state. 2. Number of poles where structural inspection requires special equipment to access. 3. Number of poles with structural defects. The defects do not significantly affect the structural capacity. 4. Number of poles affected by damage in significant locations or quantity and has reduced structural capacity. Structural analysis is warranted or has determined repairs are essential to restore the full capacity of the element. Visual inspection indicates a base plate that is not supported by leveling nuts. 		

WSDOT categorizes overlays in to two different types. The first type, ACP and Thin Overlay, is a deck protection system intended to prolong the life of the deck and wearing surface. The second type, Concrete Overlay, is intended to rehabilitate the deck and provide a new deck wearing surface.

ACP Overlays (BMS 800) can generally be identified in the field; the membrane below it cannot (BMS 801). Thin overlays may be identified in the field if the system has failed and chunks are missing. Deterioration of the ACP and thin overlays is not generally associated with the deterioration of the deck. The ACP may be replaced several times without exposing the concrete deck. Therefore, the condition states for the deck and overlay elements are independent and **DIFFERENT**. Spalls and delaminations are repaired (patched) on WSDOT bridges before placing the overlay. If the area of patching is known, this should be noted and recorded in the Deck element as CS2. If a new BST has been applied to an ACP surface, then the overlay element CS2 and CS3 are equal to zero.

800	Asphalt Concrete (AC) Overlay	Units - SF
------------	--------------------------------------	-------------------

This element defines an Asphalt Concrete (AC) bridge deck overlay, with or without a Bituminous Surface Treatment (BST). The quantity should equal the overlay's width times the length.

801	Asphalt Concrete (AC) Overlay with Waterproofing Membrane	Units - SF
------------	------------------------------------------------------------------	-------------------

This element defines an asphaltic concrete with waterproofing membrane bridge deck overlay. The quantity should equal the overlay's width times the length.

802	Thin Polymer Overlay	Units - SF
------------	-----------------------------	-------------------

This defines a thin polymer bridge deck overlay that is less than or equal to 0.5 inches in thickness (i.e., epoxy, methyl-methacrylate, etc.). The quantity should equal the overlay's width times the length.

1. Defects are superficial. The deck surfaces have no spalls/delaminations or previous repairs. The deck surfaces may have cracking.
2. Total area of overlay patches.
3. Total area of overlay spalls or potholes. Thin Polymer Overlays (802) may have visible delaminations and should be considered as spalls and coded in CS3.

Concrete Overlay elements are difficult to discern in the field and are identified in special provisions or Plans. When constructing modified concrete overlays, the material removed by the deck preparation (spalls and delams) is replaced with the overlay material. WSDOT considers this construction deck rehabilitation; or in other words, the concrete overlay and deck are monolithic. Therefore, CS2 and CS3 for the deck and concrete overlay will be the **SAME**. All defects noted in the concrete overlay (SF) apply to the deck. It is not uncommon to have the overlay break up when there is a problem in the deck below it.

803	Modified Concrete Overlay	Units - SF
------------	----------------------------------	-------------------

This defines a rigid modified concrete bridge deck overlay that is normally 1.5 inches or greater in thickness (i.e. Latex (LMC), Microsilica (MMC), Fly Ash (FMC) etc.). The quantity should equal the overlay's width times the length.

804	Polyester Concrete Overlay	Units - SF
------------	-----------------------------------	-------------------

This defines a rigid polyester concrete bridge deck overlay that is normally 0.75 inches in thickness. The quantity should equal the overlay's width times the length.

1. Defects are superficial. The deck surfaces have no spalls/delaminations or previous repairs. The deck surfaces may have hairline cracks or rock pockets.
2. Concrete overlay area with repairs or patches. Do not include the rare cases of rutting that has been filled with patching material.
3. Concrete overlay area with spalling.
4. If the results of deck delamination testing are available from Element 376, include the delaminated area in this CS4.

4.15 Bridge Deck Overlays

805 AC Over a Polymer Overlay **Units - SF**

This defines an asphaltic concrete applied over a thin polymer bridge deck overlay (i.e., epoxy, methyl-methacrylate, etc.). The quantity should equal the overlay's width times the length.

1. Defects are superficial. The deck surfaces have no spalls/delaminations or previous repairs. The deck surfaces may have cracking.
2. ACP overlay area with patches.
3. ACP overlay area with spalls or potholes.

806 BST on Concrete (Chip Seal) **Units - SF**

This defines a Bituminous Surface Treatment (BST), or commonly known as a chip seal, mistakenly applied directly on a concrete deck. This severely limits the inspection of the deck. **Code the area of BST covering the concrete deck in CS1.**

4.16 Protective Coatings

WSDOT inspectors must not change paint elements for state bridges. Inspectors will be notified with a sticky note if the bridge has been repainted.

Steel Paint Area

The steel paint area is equal to the surface area of the steel members in the bridge. An estimate of the steel paint area may be made if bridge plans are not available but the steel tonnage is known. The following table provides an approximate conversion factor:

Bridge Type	Square Feet Per Ton
Rolled or Plate Girder	110
Truss	160

901 Red Lead Alkyd Paint System **Units - SF**

This paint protection system is a 3-coat alkyd system incorporating lead based paint. Use this paint element as a default if the paint was installed prior to 1991.

902 Inorganic Zinc/Vinyl Paint System **Units - SF**

This paint protection system consists of an inorganic zinc silicate shop applied primer system and a vinyl is paint applied after erection, cleaning, and spot priming.

903 Inorganic Zinc/Urethane Paint System **Units - SF**

This paint protection system consists of a inorganic zinc silicate shop applied primer system and an epoxy, aliphatic urethane paint system applied after erection, cleaning, and spot priming. This paint system is used on new WSDOT steel bridges.

904 Organic Zinc/Urethane Paint System Units - SF

This paint protection system is a 3-coat system incorporating an organic zinc primer, an epoxy second coat and a moisture cured urethane topcoat. Use this paint element as a default if the paint was installed after 1991.

905 Coal Tar Epoxy Paint System Units - SF

This paint protection system incorporates a coal tar epoxy based product.

1. The paint system is sound and functioning as intended to protect the metal surface.
2. Paint system area with chalking, peeling, curling or showing other early evidence of paint system distress, but there is no exposure of metal.
3. Paint system area that is no longer effective. The metal substrate is exposed.



906 Metalizing Units - SF

This protection system consists of a sprayed coating of zinc or zinc/aluminum.

907 Galvanizing Units - SF

This protection system consists of zinc applied to steel in a variety of spray-on methods.

908 Epoxy Paint for Weathering Steel Units - SF

This protection system consists of a clear epoxy coating applied to weathering steel to prevent excessive corrosion.

1. Protection system area that is sound and functioning as intended to protect the metal surface.
2. Protection system area with corrosion of the substrate metal.

909 Zinc Primer

Units - SF

This paint protection system consists of a zinc silicate shop applied primer system.

1. The paint system is sound and functioning as intended to protect the metal surface.
2. Protection system area with chalking, peeling, curling or showing other early evidence of paint system distress, but there is no exposure of metal.
3. Protection system area that is no longer effective. The metal substrate is exposed.



910 Weathering Steel Patina

Units - SF

This protection system consists of a chemical compound formed on the surface of weathering steel elements and is called the patina. When exposed to the atmosphere, weathering steel develops a patina, which seals and protects the steel from further corrosion. This oxide film is actually an intended layer of surface rust, which protects the member from further corrosion and loss of material thickness. The patina acts like a paint system to protect the steel. The color is an indicator of the condition of the patina may vary from orange to dark brown or purple-brown.

1. Weathering steel color is yellow orange to light brown. Some areas may not have rust. Patina has a dusty to granular texture.
2. Weathering steel area that is chocolate brown or purple brown in color (boldly exposed) and in good condition. The patina is tightly adhered, capable of withstanding hammering or vigorous wire brushing. The patina system is sound and functioning to protect the metal surface.
3. Weathering steel area that is black in color indicating non-protective patina. Area that remains damp for long periods of time due to rain, condensation, leaky joints, traffic spray or other source of moisture. Area where debris has accumulated on a horizontal surface and the steel is continuously wet. Area with a texture of large granules (greater than 1/8" diameter); flaking (greater than 1/4" diameter) or laminar rusting in thin sheets.



