

PLAN VIEW

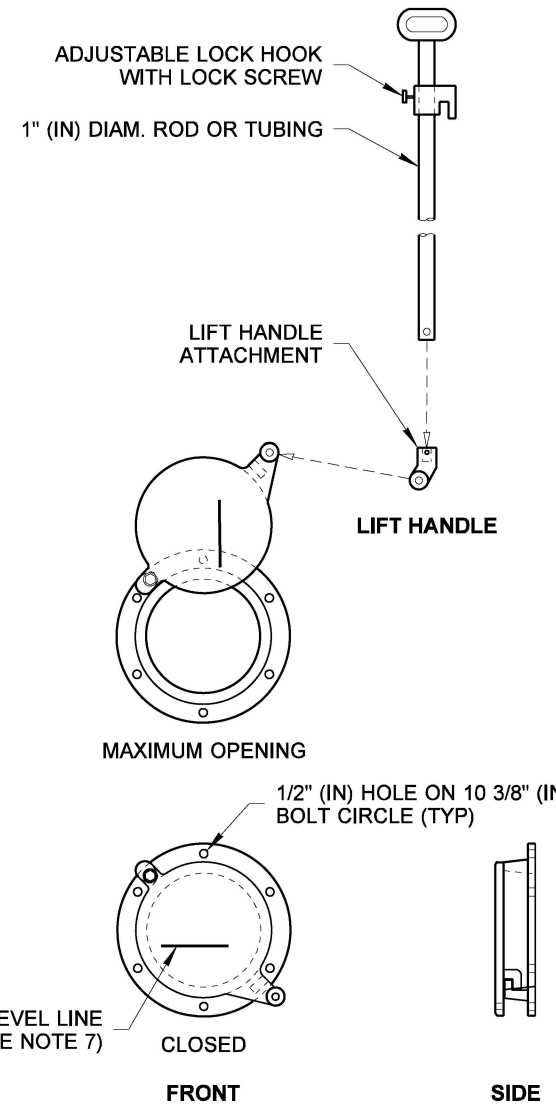

SHEAR GATE DETAILS

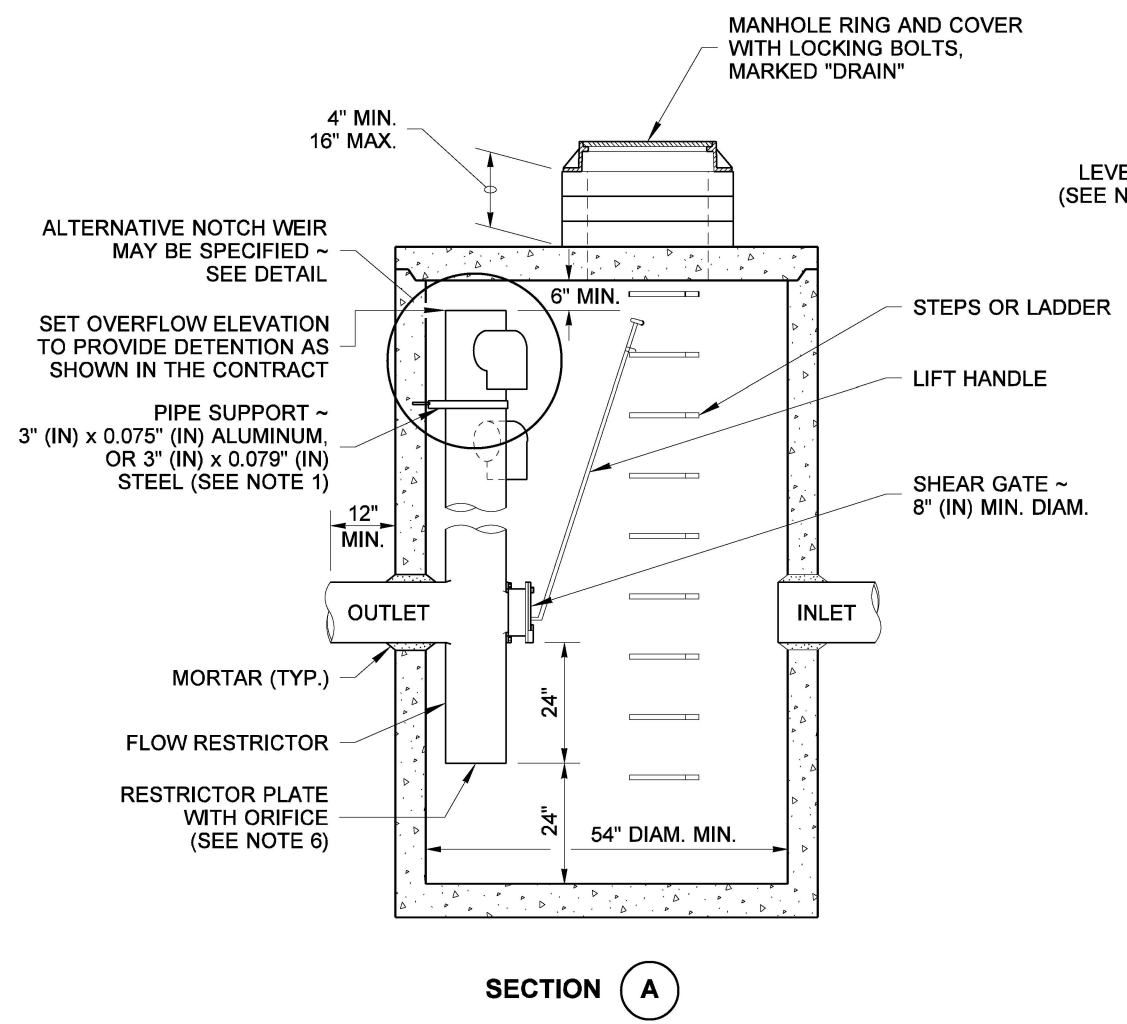

SECTION A

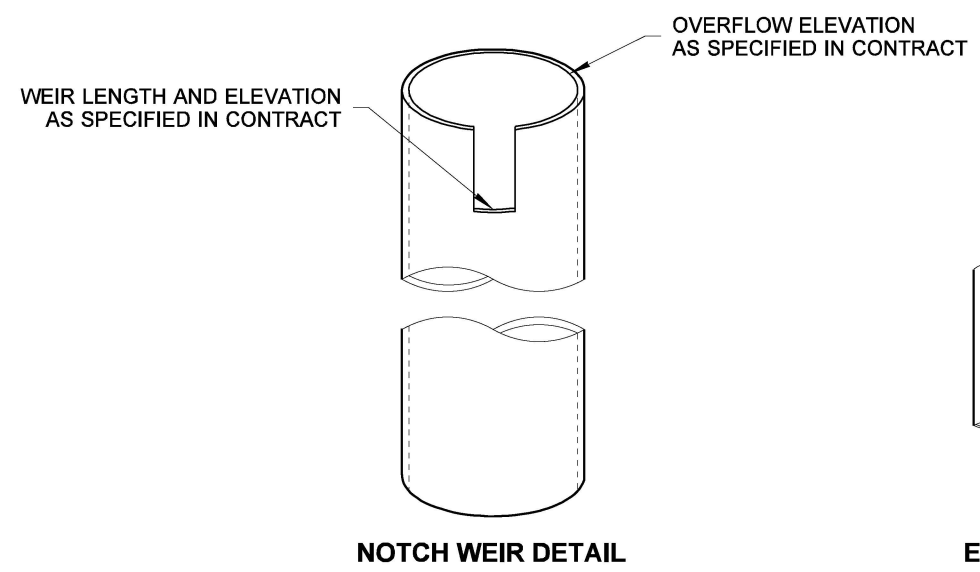

NOTCH WEIR DETAIL

ELBOW DETAIL

NOTES

- The pipe supports and the flow restrictor shall be constructed of the same material and be anchored at a maximum spacing of 36" (in). Attach the pipe supports to the manhole with 5/8" (in) stainless steel expansion bolts or embed the supports into the manhole wall 2" (in).
- The vertical riser stem of the flow restrictor shall be the same diameter as the horizontal outlet pipe with a minimum diameter of 12" (in).
- The flow restrictor shall be fabricated from one of the following materials:
 - 0.060" (in) Corrugated Aluminum Alloy Drain Pipe
 - 0.064" (in) Corrugated Galvanized Steel Drain Pipe with Treatment 1
 - 0.064" (in) Corrugated Aluminized Steel Drain Pipe
 - 0.060" (in) Aluminum alloy flat sheet, in accordance with **ASTM B 209, 5052 H32 or EPS**
 - High Density Polyethylene Storm Sewer Pipe
- The frame and ladder or steps are to be offset so that: the shear gate is visible from the top; the climb-down space is clear of the riser and gate; the frame is clear of the curb.
- The multi-orifice elbows may be located as shown, or all placed on one side of the riser to assure ladder clearance. The size of the elbows and their placement shall be specified in the Contract.
- Restrictor plate with orifice as specified in the Contract. The opening is to be cut round and smooth.
- The shear gate shall be made of aluminum alloy in accordance with **ASTM B 26 and ASTM B 275, designation ZG32A**; or cast iron in accordance with **ASTM A 48, Class 30B**.
 The lift handle shall be made of a similar metal to the gate (to prevent galvanic corrosion), it may be of solid rod or hollow tubing, with adjustable hook as required.
 A neoprene rubber gasket is required between the riser mounting flange and the gate flange.
 Install the gate so that the level-line mark is level when the gate is closed.
 The mating surfaces of the lid and the body shall be machined for proper fit.
 All shear gate bolts shall be stainless steel.
- The shear gate maximum opening shall be controlled by limited hinge movement, a stop tab, or some other device.
- Alternative shear gate designs are acceptable if material specifications are met.



Aug 17, 2021

**CATCH BASIN TYPE 2
WITH FLOW RESTRICTOR
STANDARD PLAN B-10.40-02**

SHEET 1 OF 1 SHEET

APPROVED FOR PUBLICATION

 Aug 17, 2021
 STATE DESIGN ENGINEER
 Washington State Department of Transportation