

DRAWN BY: FERN LIDDELL

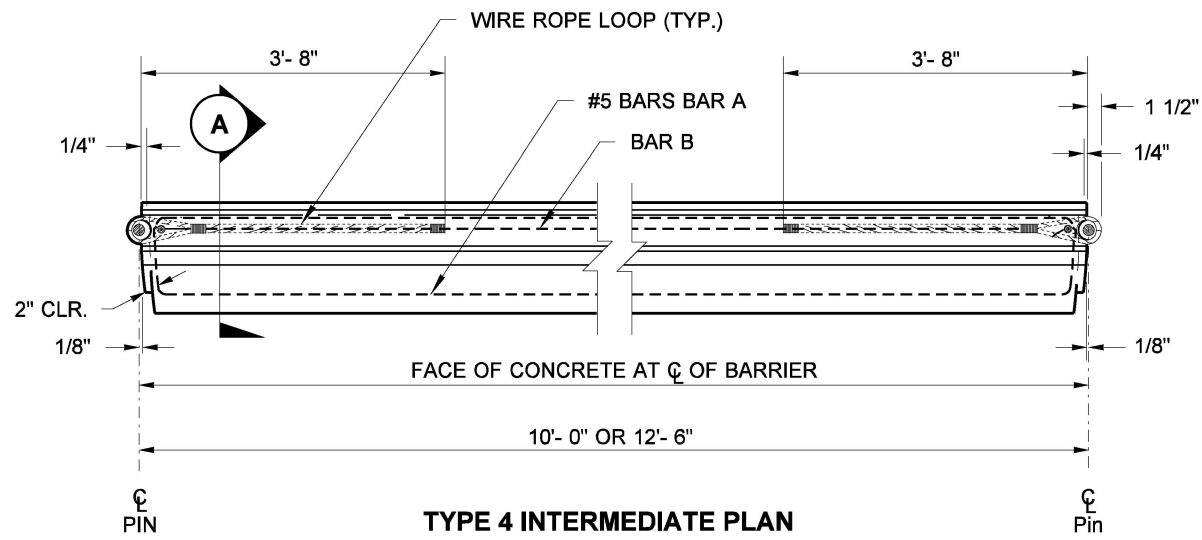

TYPE 4 INTERMEDIATE PLAN

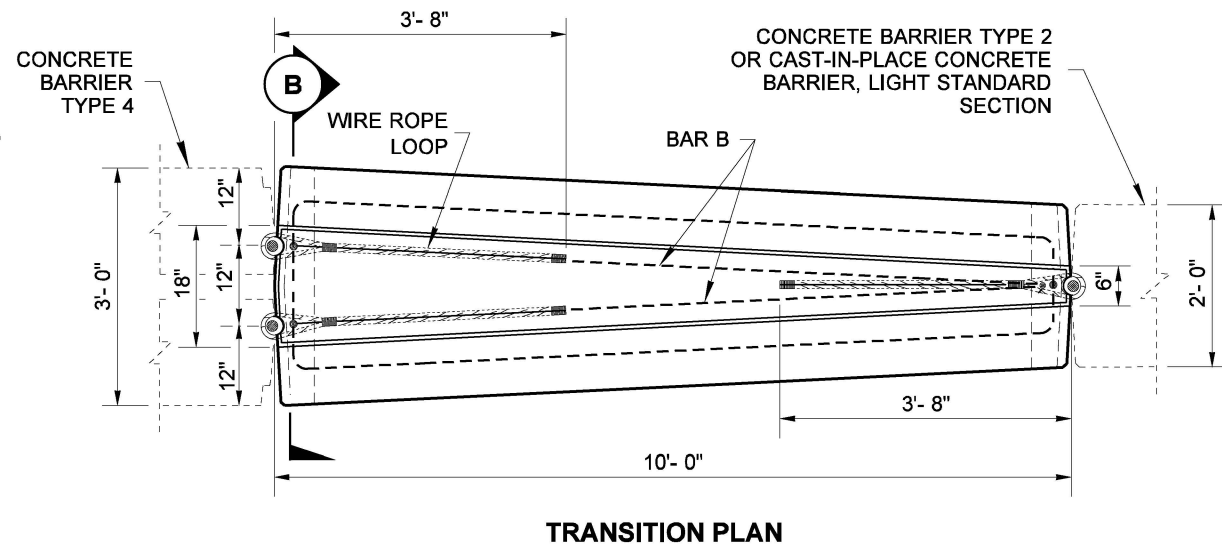

TRANSITION PLAN

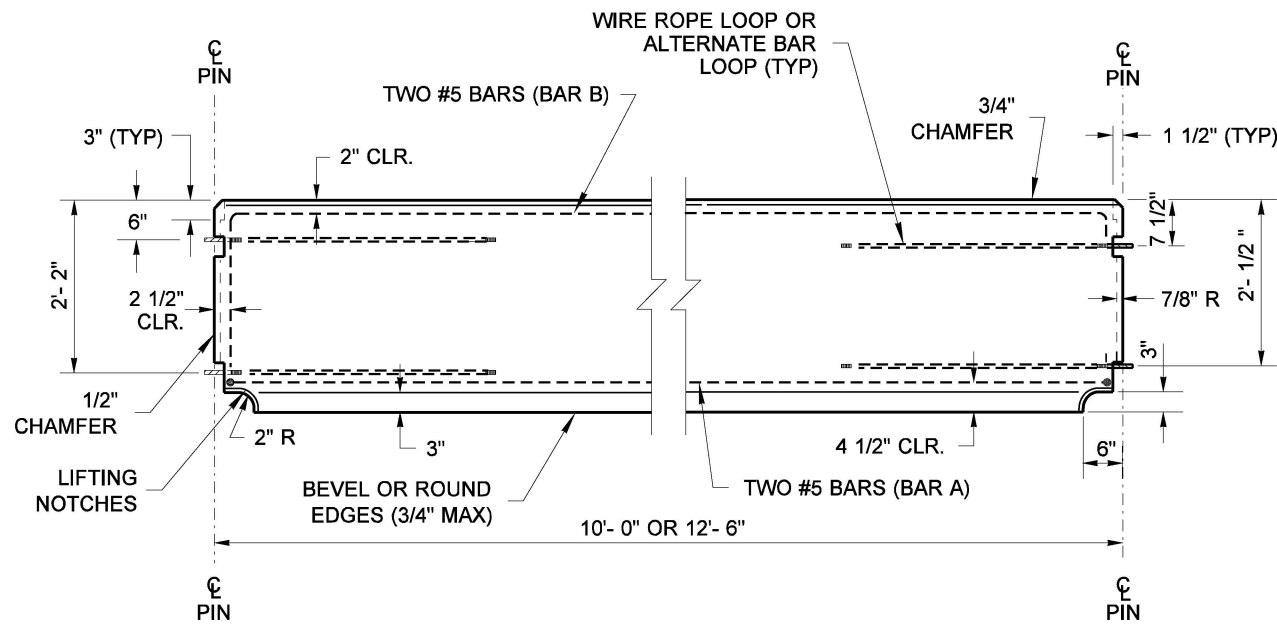

TYPE 4 INTERMEDIATE ELEVATION

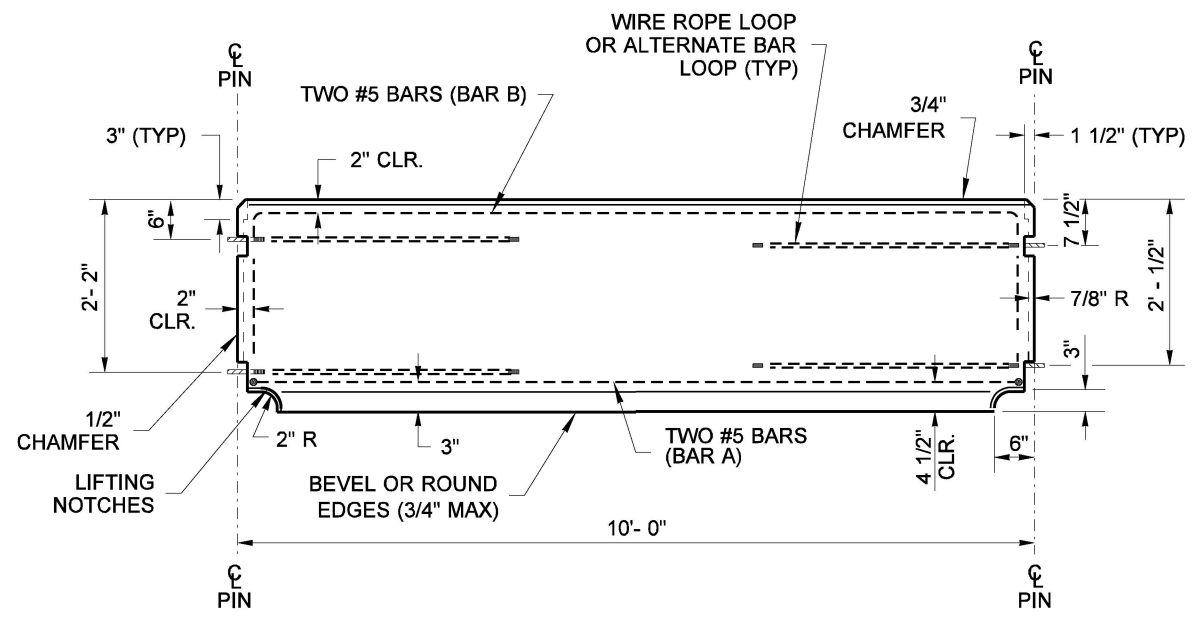

TRANSITION ELEVATION

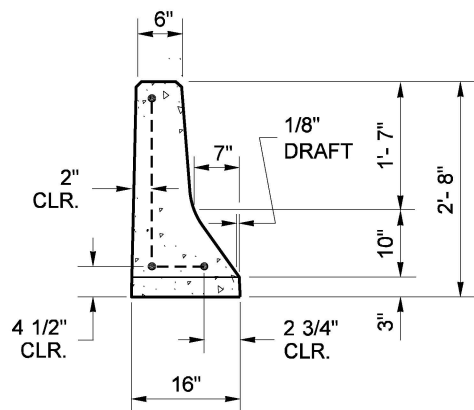

**SECTION A
TYPE 4**

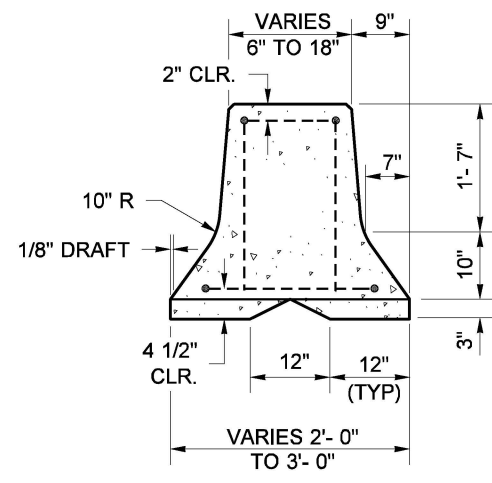

**SECTION B
TRANSITION SECTION**

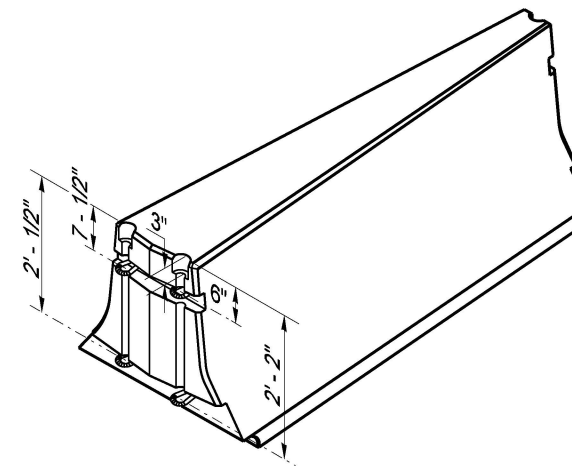

**TRANSITION END VIEW
ISOMETRIC VIEW**

NOTES

1. Type 4 Barrier and Barrier Transitions are allowed in temporary transitions only. Do not install new Type 4 barrier and barrier Transitions fabricated after December 31, 2019. This plan is provided as a means to verify that any Type 4 Barrier and Barrier Transitions fabricated prior to December 31, 2019 meet the plan requirements and cross-sectional dimensions as specified in **Standard Specifications Section 6-10.3(5)**.
2. For details on wire rope loop, connecting pin and end notches see **Standard Plan K-80.32 - Concrete Barrier Type 2**.



Aug 17, 2021

**CONCRETE BARRIER TYPE 4
AND TRANSITION SECTION
STANDARD PLAN K-80.34-00**

SHEET 1 OF 1 SHEET

APPROVED FOR PUBLICATION

[Signature]

Aug 17, 2021

STATE DESIGN ENGINEER



Washington State Department of Transportation