

P2.1	General
P2.2	AWS Needs Studies and Factors
P2.3	Preliminary Countermeasures
P2.4	System Layout
P2.5	Sign Mounting
P2.6	PTSWF Signs
P2.7	ICWS Major Roadway Signs
P2.8	ICWS Minor Roadway Signs
P2.9	RCWS Signs
P2.10	Operation
P2.11	Quick Reference Tables
P2.12	References
P2.13	Sign Fabrication Details

P2.1 General

An Advanced Warning System (AWS) is an actuated system that provides advance warning of a condition which may require a vehicle to stop, but the condition is not always present. These systems consist of an actuation system, signs, and beacons. There are three primary types of AWS:

1. Prepare to Stop When Flashing (PTSWF). This type of system is typically installed on an approach to a signalized intersection where conditions (sight distance, visibility, grades, truck percentage) indicate that additional warning time for approaching drivers is needed. The system activates when phase termination (the change from green to yellow) is about to occur. The goal of this type of system is to provide additional warning and decision time to drivers on a specific approach to an intersection so that they can make a more controlled stop at the intersection, ideally resulting in reductions of hard stops, red light running, and rear-end collisions – particularly by large vehicles. Although normally used to supplement a traffic signal system, this type of AWS system can be modified to address any location where a temporary stop condition may be expected.
2. Intersection Conflict Warning System (ICWS). This type of system is installed at an intersection where either mainline traffic is unable to see entering cross traffic, mainline traffic is unable to see a queue that has developed ahead (typically roadways with no turn lane channelization), cross traffic is unable to determine gaps in mainline traffic, or a combination of these. The goal of this type of system is to provide a visible warning of approaching, entering, or stopped traffic, as appropriate, so that drivers can make a safer decision regarding their actions at an intersection, ideally resulting in reductions of both crossing and rear-end collisions – particularly involving large vehicles. AWS for freeway off-ramp intersection queues that may back up onto the freeway are considered a type of ICWS.

3. Rail Crossing Warning System (RCWS). This type of system is installed on an approach with a rail crossing, or on an approach with a crossroad with a nearby rail crossing, where the crossing or stopped traffic for the crossing are not visible from an adequate distance. The goal of this type of system is to provide advance warning of the need to stop for the rail crossing (or traffic stopped for the crossing), ideally resulting in reductions of hard stops, rear-end collisions, and crossing signal running – particularly by large vehicles. A modified version of an RCWS may serve to redirect traffic away from an active rail crossing. RCWS requires coordination with the associated railroad, which should be initiated as early as possible due to long response and equipment availability times.

AWS should be evaluated within one year of installation. If the system is not shown to have reduced collisions, consider removal of the AWS and replacement with an alternate countermeasure as described in Section P2.3. Existing systems in operation should be evaluated but are not required to be modified to meet these standards unless determined to have poor effectiveness.

Sign fabrication details for all signs is provided in Section P2.13.

For signalized intersections with a railroad interconnect (railroad pre-emption), the region Signal Operations Engineer will determine if PTSWF can be implemented if justified. Due to the immediate timing changes that occur with railroad pre-emption, it may not be possible to implement PTSWF.

P2.2 AWS Needs Studies and Factors

An engineering study of traffic conditions and physical characteristics of a location shall be performed to determine whether installation of an AWS is justified at a particular location. A speed study shall be conducted to determine actual 85th and 90th percentile speeds needed for the formulas presented here.

AWS are not likely to provide noticeable benefits on lower speed facilities. PTSWF shall not be considered for intersection approaches with a posted speed of 40 MPH or less. ICWS and RCWS shall not be considered where the approach to the intersection or rail crossing has a posted speed of 30 MPH or less.

The investigation of the need for an AWS shall include an analysis of factors related to the existing operation and safety at the study location and the potential to improve these conditions, and the applicable factors contained in the following AWS warrants:

- Warrant 1: Limited Sight Distance
- Warrant 2: General Truck Downgrade
- Warrant 3: Collision History
- Warrant 4: Engineering Judgement
- Warrant 5: Isolated or Unexpected Signal (PTSWF only)
- Warrant 6: Truck Downhill Dilemma Zone (PTSWF only)

The satisfaction of one or more warrants does not in itself require the installation of an AWS. An AWS should not be installed unless an engineering study indicates that the installation will improve the overall safety and/or operation of the location.

P2.2(1) Warrant 1: Limited Sight Distance

The intersection, rail crossing, or end of queue is not visible within design stopping sight distance for that approach. Visibility for this situation depends on the type of intersection control:

1. For signalized intersections and mainline rail crossings, visibility is the ability to see at least two signal displays (in case one display fails).
2. For non-signalized intersections and side road rail crossings, visibility is the ability to see one of the following, as applicable:
 - a. A stopped vehicle on the crossroad.
 - b. A stopped vehicle at the rail crossing stop line.
 - c. A stopped vehicle waiting to make a turn.
 - d. The rear of the queue behind a vehicle waiting to make a turn.

More than one of these conditions may apply or may apply on more than one approach to the intersection.

Note that queue warnings are not normally evaluated separate from the basic system type sight distance evaluation unless the queue length is extremely long. Instead, warning system placement is adjusted to address queue visibility. Where queues are extremely long, this may result in an independent queue warning system.

Limited Sight Distance is determined by Equation P2.2-1:

$$D \leq 1.47V_{85}t + \frac{V_{85}^2}{0.93 \left[a + 32.2 \left(\frac{G}{100} \right) \right]} \quad \text{Equation (P2.2-1)}$$

Where:

- D =
 - For PTSWF: Distance to the stop line, in feet (see Exhibit P2.2-1); If the second signal display for that approach (such that if one display fails, the other is still visible) is not visible from this distance, then this warrant is met.
 - For ICWS: Distance to the nearest crossroad lane edge (before the radius return starts; see Exhibit P2.2-2)
 - For RCWS:
 - Where the rail crossing is on the mainline highway: Distance to the nearest stop line for the rail crossing, in feet (see Exhibit P2.2-3).

- Where the rail crossing is on an intersecting roadway: Distance to the nearest edge line of the crossroad, in feet (see Exhibit P2.2-2).
- V_{85} = 85th Percentile Speed, in mph; as determined by a speed study.
- $t = 2.5$; Perception-Reaction time, in seconds.
- a = deceleration rate, in feet / seconds²;
 Use $a = 8$, unless trucks are prohibited on the approach. If trucks are prohibited on the approach, use $a = 10$. (See Reference 4)
- G = grade, in percent;
 Uphill approach is positive (+), downhill approach is negative (-).

Exhibit P2.2-1: Stopping Sight Distance for PTSWF



Exhibit P2.2-2: Stopping Sight Distance for ICWS or Side Road RCWS

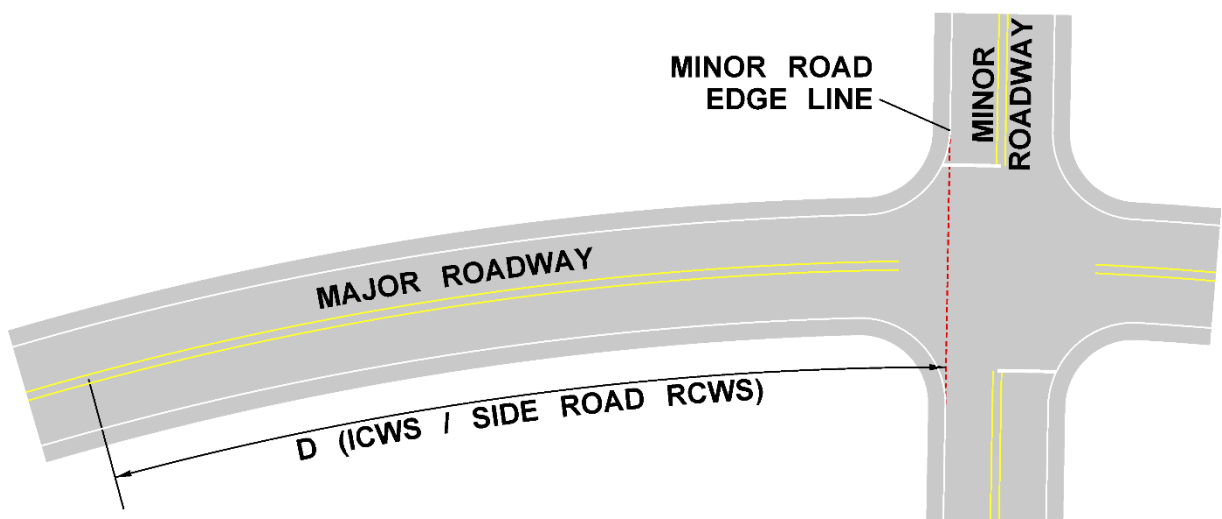
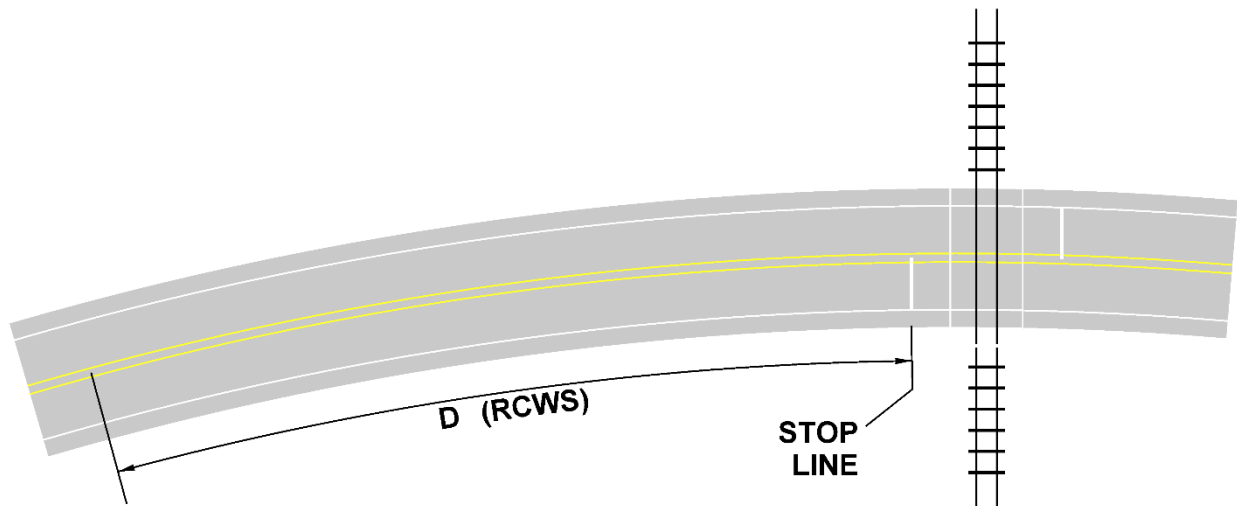

Exhibit P2.2-3: Stopping Sight Distance for RCWS**P2.2(2) Warrant 2: General Truck Downgrade**

At locations where vehicles are required to stop for a specific condition, trucks may not have sufficient stopping sight distance on a downgrade due to their increased braking distance. Where this is the case, an AWS shall be considered if the approach has a downgrade of 3% or greater and greater than 15% truck volume.

P2.2(3) Warrant 3: Collision History

There is a documented history of collisions on the approach, which have not been correctable through other means. The type of AWS to consider will depend on the type of collision(s).

Examples:

- Rear-end collisions may support the use of a PTSWF system (signalized intersection), ICWS (unsignalized intersection), RCWS (rail crossing), or QWS (any other location where a queue develops)
- Angle collisions may support the use of a PTSWF system (signalized intersection) or ICWS (unsignalized intersection)

Collision history shall use data over a three-year period. It is recommended that the number of collisions referenced in FHWA Interim Approval 19

(https://mutcd.fhwa.dot.gov/resources/interim_approval/ia19/index.htm) for a three-year period be used as a general guide for the number of collisions of a particular type (rear-end or angle) that may justify an AWS.

P2.2(4) Warrant 4: Engineering Judgement

An Engineering Study or documented evidence of issues such as verified complaints, field observations of red light running, field observations of hard braking or skid marks (particularly from large trailers), or similar may be determined to justify an AWS. Requires approval from the Region Traffic Engineer.

P2.2(5) Warrant 5: Isolated or Unexpected Signal (PTSWF Only)

The signalized intersection is located 10 miles or more from the last signalized intersection, is located at the end of a freeway/expressway, or in a similar location where a signal would not normally be expected. Document the condition that makes the signal unexpected for drivers on that approach. It should be noted that PTSWF systems are less effective in urban areas, where there are a larger number of potential conflicts that may require a sudden stop and approach speeds are generally lower.

P2.2(6) Warrant 6: Truck Downhill Dilemma Zone (PTSWF Only)

On a downhill approach, the upstream end of the signal dilemma zone detection (UDZ_{90}) is closer to the stop line than the safe stopping sight distance for trucks (SSD_T), as determined by Equations P2.2-1, P2.2-2, and P2.2-3:

$$UDZ_{90} < SSD_T \quad \text{Equation (P2.2-1)}$$

$$UDZ_{90} = \frac{V_{90}^2}{2 \left[a + 32.2 \left(\frac{G}{100} \right) \right]} \quad \text{Equation (P2.2-2)}$$

$$SSD_T = 1.47V_{85}t + \frac{V_{85}^2}{0.93 \left[a + 32.2 \left(\frac{G}{100} \right) \right]} \quad \text{Equation (P2.2-3)}$$

Where:

- V_{90} = 90th Percentile Speed, in mph; as determined by a speed study.
- a = 8; deceleration rate, in feet / seconds². (See Reference 4)
- G = grade, in percent; G is always negative (-).
- V_{85} = 85th Percentile Speed, in mph; as determined by a speed study.
- t = 2.5; Perception-Reaction time, in seconds.

Warrant 6 may not be used if trucks are prohibited on the approach.

P2.3 Preliminary Countermeasures

The following countermeasures should be attempted, and shown to be insufficient, in the order shown below, before implementing an AWS:

1. Installation or Revision of Dilemma Zone Detection, as applicable (PTSWF only). This countermeasure may not show improvement for a few years.
2. Improving sight distance, including obstruction removal or adding supplemental signal displays.
3. Speed limit revisions, if appropriate; enforcement support is needed. For signalized intersections, dilemma zone detection modification is also required if the speed limit is changed.
4. Revision of signal timing (PTSWF only); adjustment of Yellow Clearance Interval, in particular (adjustment of Red Clearance Interval may also help).
5. Installation of a single 48" x 48" Signal Ahead (W3-3) sign or applicable W Series Warning (W2-1 Cross Road Symbol, W2-2 Side Road Symbol, etc.) sign.
6. Installation of dual (gated) 48" x 48" Signal Ahead (W3-3) signs or applicable W Series Warning signs, for two lane, three lane, and divided (median or barrier with sufficient shoulder width) highways.
7. Installation of a single 48" x 48" Signal Ahead (W3-3) sign or applicable W Series Warning sign with actuated alternating flashing beacons.

For traffic signal systems, evaluation of countermeasures should be done as part of signal operations preventative maintenance/routine evaluation (at a minimum – more frequently is acceptable). Documentation of countermeasures attempted and routine evaluations should be included in the SIMMS Database as part of Work History or under the Documents Tab, as appropriate.

P2.4 System Layout

AWS installations depend on the system type. PTSWF and RCWS are limited to one or more advance warning signs and are a supplement to a primary control system: traffic signal for PTSWF, railroad crossing with red flashing lights (at a minimum) for RCWS. ICWS are standalone systems composed of both advance warning signs and sensors.

ICWS elements will depend on the conflict being addressed:

- Minor road signs with major road sensors. Used when minor roadway traffic needs to be warned of vehicles on the major roadway within a certain distance of the intersection. This type of system is normally used where minor road traffic has difficulty seeing major roadway traffic for a sufficient distance to determine gap length.
- Major road signs with minor road sensors. Used when major roadway traffic needs to be warned of vehicles potentially entering from the minor roadway.

- Major road signs with stopped or turning traffic sensors. Used when major roadway traffic needs to be warned of traffic turning across or into the major roadway, or when stopped traffic may be present.

Great care is required in the design and application of all system types, as drivers may develop an overdependence on the system, which can result in undesirable outcomes should there be a system failure of some type (power loss, sensor failure, beacon failure, etc.). The signing requirements provided here are one method to try and address potential electrical system failure.

P2.4(1) Major Roadway Sign Placement

Where warning signs are required on the major roadway as part of an AWS, they shall be installed on the major roadway (typically the mainline highway) at a location relative to the stopping sight distance of the roadway, as determined by Equation P2.4-1 or P2.4-1A:

$$\text{ICWS/RCWS:} \quad D_S = \left\{ 1.47V_{85}t + \frac{V_{85}^2}{30 \left[\frac{a}{32.2} + \left(\frac{G}{100} \right) \right]} \right\} - 180 \quad \text{Equation (P2.4-1)}$$

$$\text{PTSWF Only:} \quad D_S = 1.47V_{85}t + \frac{V_{85}^2}{30 \left[\frac{a}{32.2} + \left(\frac{G}{100} \right) \right]} \quad \text{Equation (P2.4-1A)}$$

Where:

- $D_S =$
 - For PTSWF or RCWS Mainline Crossing: Distance to the stop line, in feet (see Exhibit P2.4-1).
 - For ICWS or RCWS Side Road Crossing: Distance to the nearest crossroad lane edge (before the radius return starts), in feet (see Exhibit P2.4-1).
 - For ICWS for turning traffic or a queue: Distance to where a stopped vehicle is visible from calculated stopping sight distance, in feet (see Exhibit P2.4-2)
- V_{85} = 85th Percentile Speed, in mph; as determined by a speed study
- t = 2.5; Perception-Reaction time, in seconds
- a = 8 or 10; deceleration rate, in feet / seconds²;
Use $a = 8$ unless trucks are prohibited on the approach. (See Reference 4)
- G = grade, in percent; uphill approach is positive (+), downhill approach is negative (-)

Note: The sign position is 180 feet closer to the intersection (-180 at end of Equation P2.4-1) than the actual calculated stopping sight distance for sign legibility distance for ICWS and RCWS, as discussed in MUTCD Section 2C, Table 2C-4, footnote 3. For PTSWF systems, signal timing is based on a vehicle passing the sign being able to safely clear the intersection, and can be

adjusted to accommodate variations, so the 180-foot adjustment is not included (Equation P2.4-1A).

The AWS sign location on the major roadway is dependent on the number of through lanes on the approach:

- For a single lane approach, one AWS sign shall be installed on the right shoulder of the roadway.
- For a multilane approach with a median or barrier with sufficient shoulder width, dual (gated) AWS signs shall be installed – one on each side of the approach.
- For a multilane approach without a median, one overhead sign shall be installed. As an alternative, two enhanced ground signs (see [Section P2.5](#)) may be shoulder mounted if there is sufficient visibility of the left sign across the oncoming traffic lanes.
- Basic ground mounted signs should not be considered for highways with functional classifications of R1, R5, U1, or U5 (urban and rural principal arterials and freeways).

For convenience, typical major roadway sign placement locations are shown in the tables in Section P2.11. Exhibit P2.4-1 shows the basic concept of major roadway sign placement.

For ICWS, a supplemental second warning sign is recommended if the primary warning sign is 300 feet or more from the intersection, particularly if cross traffic approaching the minor road stop line will not be visible from the major roadway until very close to the intersection. This supplemental sign should be located 100 feet prior to the intersection and shall be a minimum of 200 feet from the primary warning sign. Supplemental signs may be considered for RCWS and shall not be used for PTSWF.

Exhibit P2.4-1: Basic Major Roadway Sign Placement

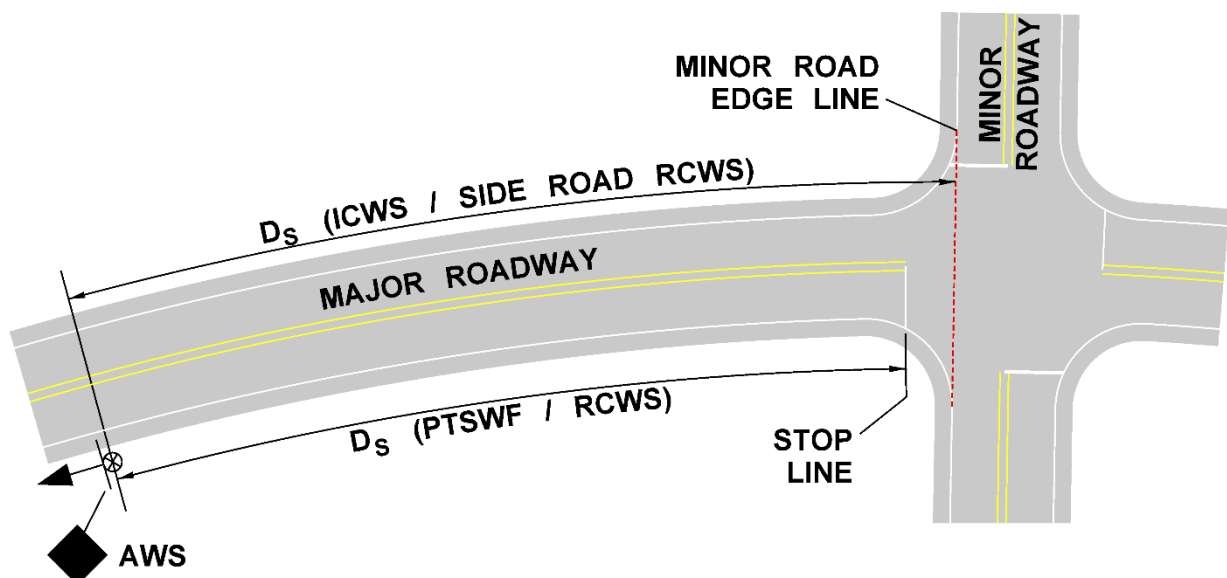
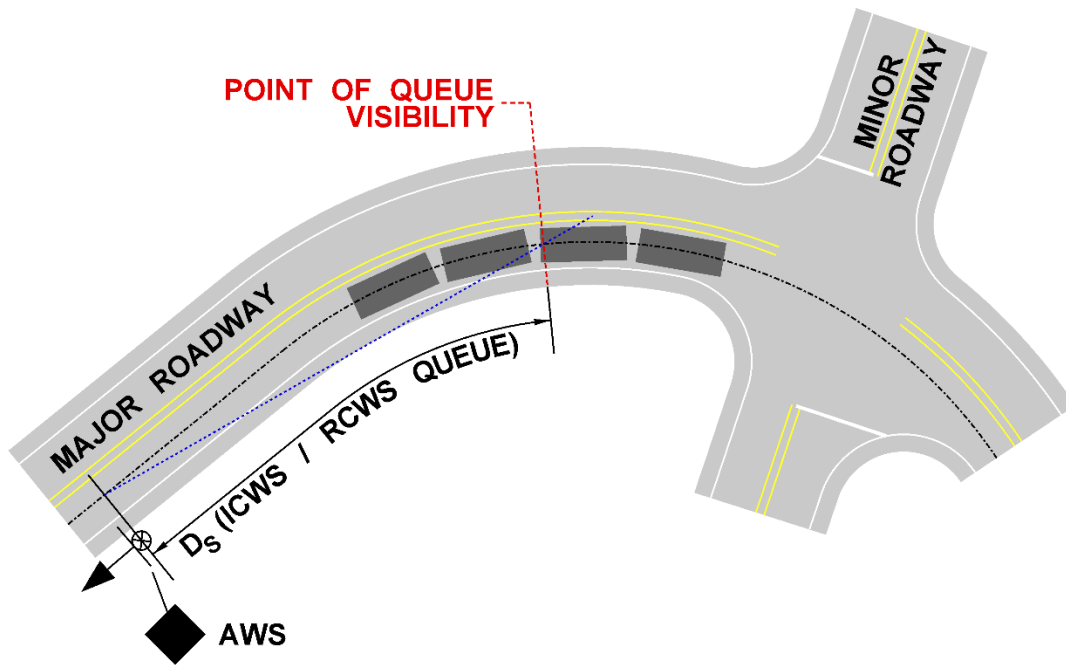

Exhibit P2.4-2: Queue Visibility Distance



For ICWS or RCWS only, sign position may need to be adjusted to address queue visibility. To determine the Point of Queue Visibility (PQV):

1. Determine the distance D_s for sign placement from Equation P2.4-1 and note this as the minimum warning sign location.
2. Draw a line from the center of the lane at this point, tangent to the inside paved shoulder edge of the curve, until it intersects the center of the lane again.
3. If the roadway centerline distance between the minimum warning sign location and the PQV is less than the D_s distance calculated in step 1 above, move the sign position back and repeat these steps until the roadway centerline distance between the warning sign location and the PQV is equal to D_s .

If the queue length is not expected to extend to the PQV, consideration may be given to measuring the warning sign distance from the back of the expected queue rather than the PQV. It is not recommended to make this adjustment on roadways with a posted speed of 40 MPH or higher, due to the difficulty in trying to predict queue length and the higher speeds involved.

For a PTSWF system, a separate queue warning system may be necessary if queue visibility is an issue. Do not adjust the position of the PTSWF signs themselves as they are based on signal timing and distance from the intersection stop line only.

P2.4(2) ICWS Minor Roadway Sign Placement

Minor roadway signs are installed as part of an ICWS when appropriate. The primary location for minor roadway signs is the far-right corner of the intersection from the minor roadway approach (or equivalent location if a T intersection). Where the major roadway is more than three lanes wide, or is a divided highway, a second supplemental sign is placed on the near left corner of the intersection. Exhibit P2.4-3 shows the typical placement of the minor roadway sign when the major roadway is no more than three lanes wide. Exhibit P2.4-4 shows typical minor roadway sign placement for wider major roadways and divided highways.

Exhibit P2.4-3: Minor Roadway Sign Placement for Major Roadways with Three or Fewer Lanes

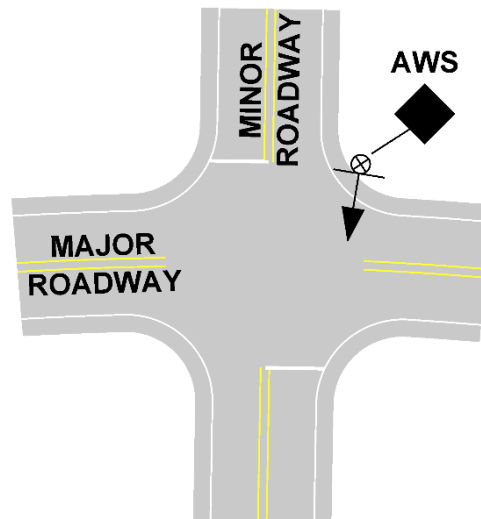
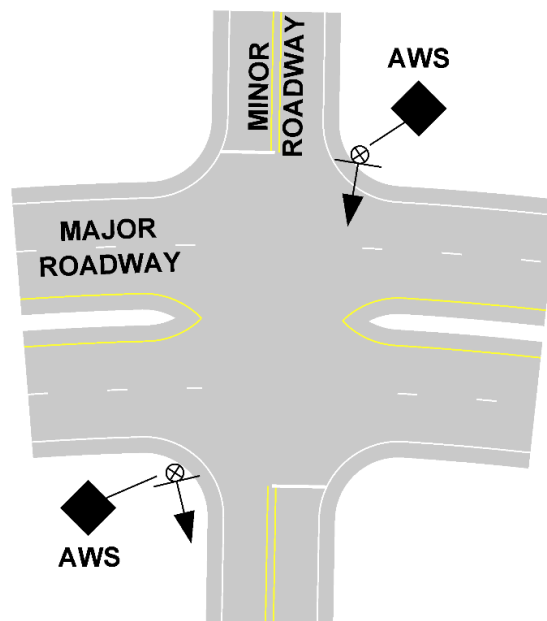

Exhibit P2.4-4: Minor Roadway Sign Placement for Major Roadways with Four or More Lanes and Divided Highways



P2.4(3) ICWS Detection Zones

Detection Zones for ICWS depend on the type of approach and the type of traffic conflict being addressed:

- Major roadway warning: Detection zones are placed in the intersection to warn traffic on the major roadway. Specific location depends on if the warning is for traffic entering from the minor roadway, if the warning is for traffic turning on to or off of the major roadway, or if the warning is for stopped traffic (queue warning).
- Minor roadway warning: Detection zones are placed on the major roadway to warn traffic on the minor roadway.

P2.4(3)(a) Major Roadway Warnings: Minor Roadway Detection Zones

Minor roadway detection zones are used to detect traffic that may be moving across the major roadway, either crossing the major roadway, turning onto the major roadway, or turning from the major roadway onto the minor roadway. Sensors for these detection zones should be either radar or infrared camera, as induction loops are difficult to place and maintain, and detection zones are not limited to rectangles but are typically odd shapes, on curves, and require adjustment to match vehicle locations.

There are four basic types of detection zones:

- Cross-traffic. This zone extends from 30 feet before the minor road stop line to the far edge line of the major roadway. Zones may be established for one or both directions of traffic, depending on site specific needs. See Exhibit P2.4-5.
- Minor road right turn. This zone covers right turns from the minor roadway onto the major roadway. This zone should extend from 30 feet before the minor road stop line to the end of the corner radius return in the receiving lane. See Exhibit P2.4-6.
- Minor road left turn. This zone covers left turns from the minor roadway onto the major roadway. This zone should extend from 30 feet before the minor roadway stop line to the end of the left side corner radius return in the receiving lane. See Exhibit P2.4-7.
- Major road left turn. This zone covers left turns from the major roadway onto the minor roadway. This zone should extend from 30 feet before the downstream end of the turn lane to the far edge line of the major roadway that is being crossed by the turning traffic. See Exhibit P2.4-8.

Minor road zones may overlap and use the same sensors and/or detection zones.

Major road right turns (traffic turning right from the major roadway onto the minor roadway) are not specifically addressed because turning traffic is not crossing a conflicting direction of traffic. However, a queue warning system may be appropriate under certain circumstances.

System timing requirements are discussed in Section P2.10(2).

Exhibit P2.4-5: Detection Area for Minor Road Cross Traffic

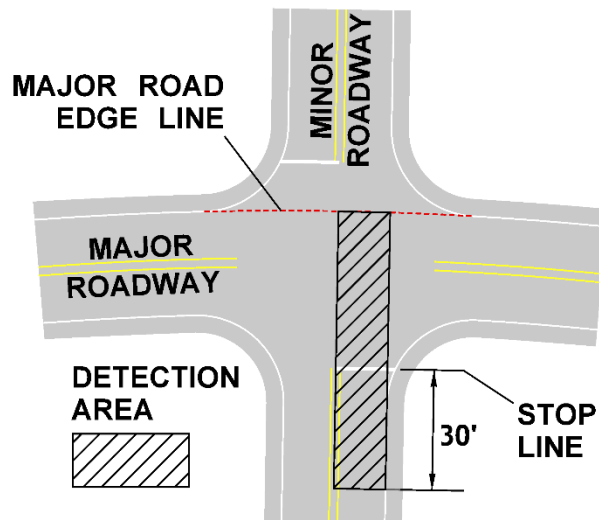

Exhibit P2.4-6: Detection Area for Minor Road Right Turns

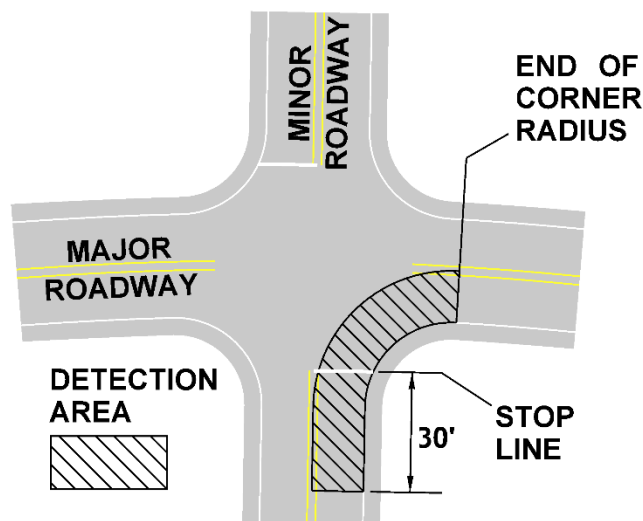

Exhibit P2.4-7: Detection Area for Minor Road Left Turns (Divided Highway Shown)

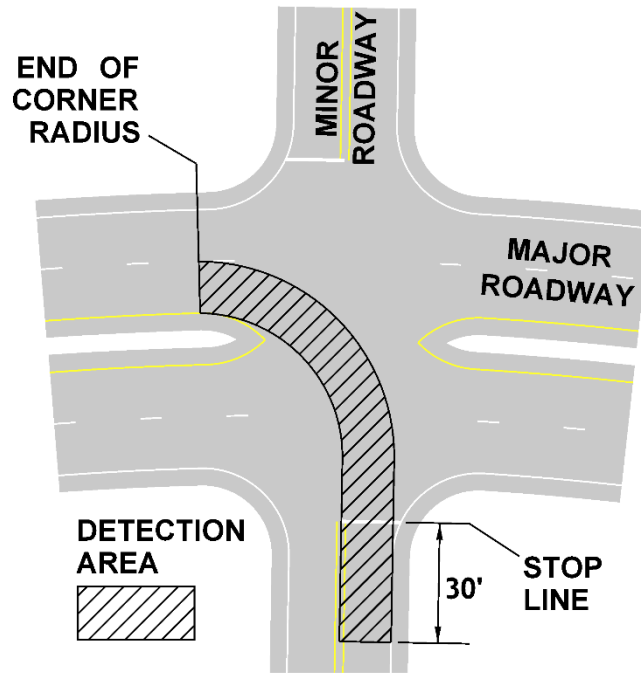
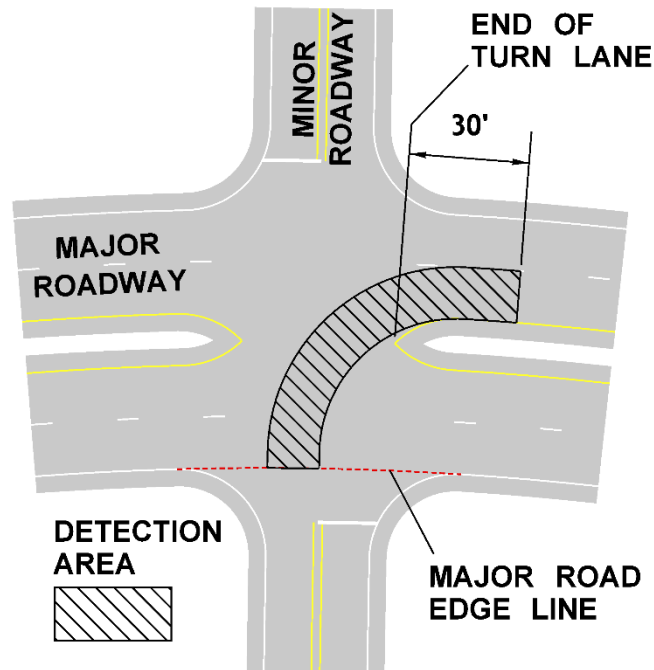

Exhibit P2.4-8: Detection Area for Major Road Left Turns



P2.4(3)(b) Major Roadway Detection Zones for Queue Detection

Major roadway detection zones for queue detection are installed at the start of the queue, such as at an intersection where the first vehicle is expected to wait to make a turn. Sensors for these detection zones should be either radar or infrared camera, as induction loops are difficult to place and maintain, and reduces the need for a vehicle to be precisely positioned to be detected.

Queue detection zones do not need to be very long (maybe 20 feet or so), as they are only detecting one vehicle stopped at the detection point. It is recommended that queue detection operate with at least a short delay, to avoid the system activating for momentary pauses in turning movements. Exact delay timing will require field observation.

Exhibit P2.4-9 shows detection zone placement for major roadway queue detection.

Exhibit P2.4-9: Detection Area for Queue

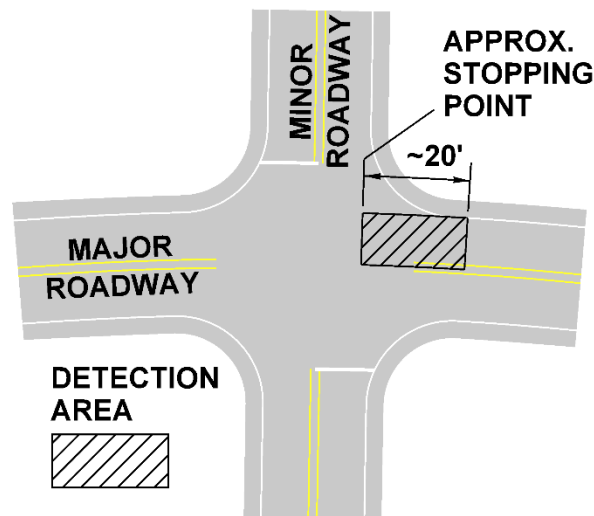

P2.4(3)(c) Major Roadway Detection Zones for Minor Roadway Warnings

Major roadway detection zones for minor roadway warnings are used to detect traffic that is closer than the stopping sight distance from the crossing roadway. The start of the detection zone is based on the stopping sight distance using equation P2.4-2 below:

$$D_D = \left\{ 1.47V_{85}t + \frac{V_{85}^2}{30 \left[\frac{a}{32.2} + \left(\frac{G}{100} \right) \right]} \right\} \quad \text{Equation (P2.4-2)}$$

Where:

- D_D = Distance to the nearest crossroad lane edge (before the radius return starts), in feet.
- V_{85} = 85th Percentile Speed, in mph; as determined by a speed study
- t = 2.5; Perception-Reaction time, in seconds

- $a = 8$ or 10 ; deceleration rate, in feet / seconds²;
Use $a = 8$ unless trucks are prohibited on the approach. (See Reference 4)
- $G =$ grade, in percent; uphill approach is positive (+), downhill approach is negative (-)

This distance is measured from the nearest edge line of the minor roadway (as carried through the intersection). There are two possible types of detection:

- Continuous Type (preferred). This type of detection uses a non-invasive sensor (radar or infrared camera) which can detect a vehicle for the entire distance from the trigger point to the intersection (or as close to the intersection as possible). Warning system timing only needs to be extended for the time between when the vehicle leaves the detection zone and the vehicle reaches the near edge line of the minor roadway. It is possible that no time extension is needed.
- Trigger Type. This type of detection is installed at the beginning of the detection zone, and may be invasive (induction loop) or non-invasive. Warning system timing is required to keep the system active while there is a vehicle in the area between the detector and the near edge line of the minor roadway.

Exhibit P2.4-10 shows detection areas for both continuous and trigger type detection zones. System timing requirements are discussed in Section P2.5(2). Detection is required on both approaches of the major roadway; these systems are not designed to clarify which direction the approaching traffic is coming from, so the warning must activate for traffic coming from either direction.

Exhibit P2.4-10: Major Roadway Detection for Minor Roadway Warnings

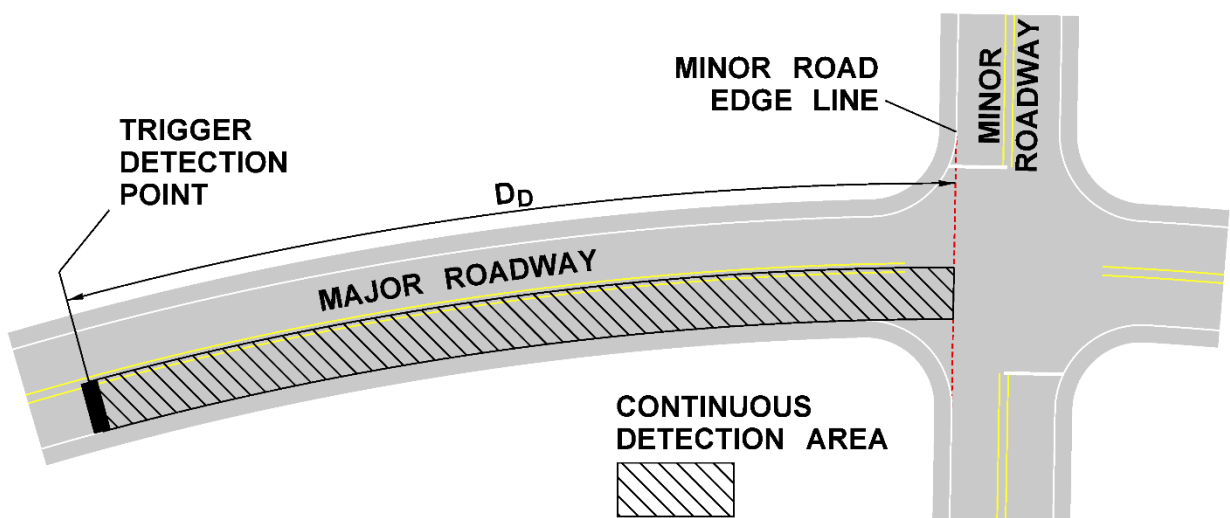

P2.5 Sign Mounting

There are four basic methods of installation for AWS signs and beacons: single-post ground mount, multi-post ground mount, overhead signal arm mount, and overhead sign structure mount. Both standard and enhanced ground mount signs may use a variation where they are installed on the column(s) of a sign structure.

P2.5(1) Single-Post Ground Mounted Sign

Smaller ground mounted AWS signs are installed on a Type FB Signal Standard with Alternating Beacons as shown in the [Standard Plans](#). The beacons shall be 12-inch diameter displays and include backplates (no reflective tape).

Exhibit P2.5-1: Standard Ground Mounted AWS Sign

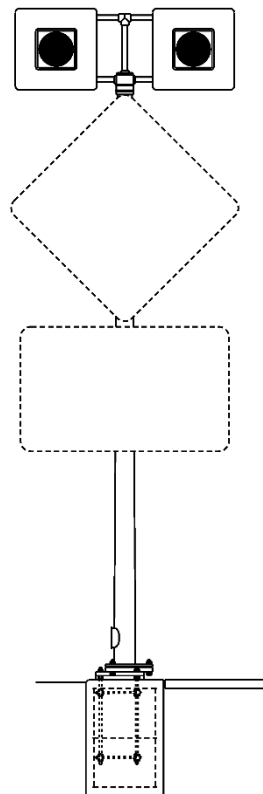

See [Standard Plan](#) J-21.16 for basic sign and pole installation details. See Standard Detail IS-22 (CRFB) for updated dual beacon installation details.

A modified version of this sign assembly may be installed on sign structure columns for freeways and expressways with only two lanes in the same direction, with the entire assembly installed as high on the sign structure column as possible. See Section P2.5(5) for where this can be used.

P2.5(2) Multi-Post Ground Mounted Sign

Larger ground mounted AWS signs are installed on multiple posts in accordance with the [Standard Plans](#). Beacons are installed over each signpost (far left and far right posts where more than two posts are used). The beacons shall be 12-inch diameter displays and include backplates (no reflective tape).

Exhibit P2.5-2: Enhanced Ground Mounted AWS Sign (Steel Post Installation Shown)

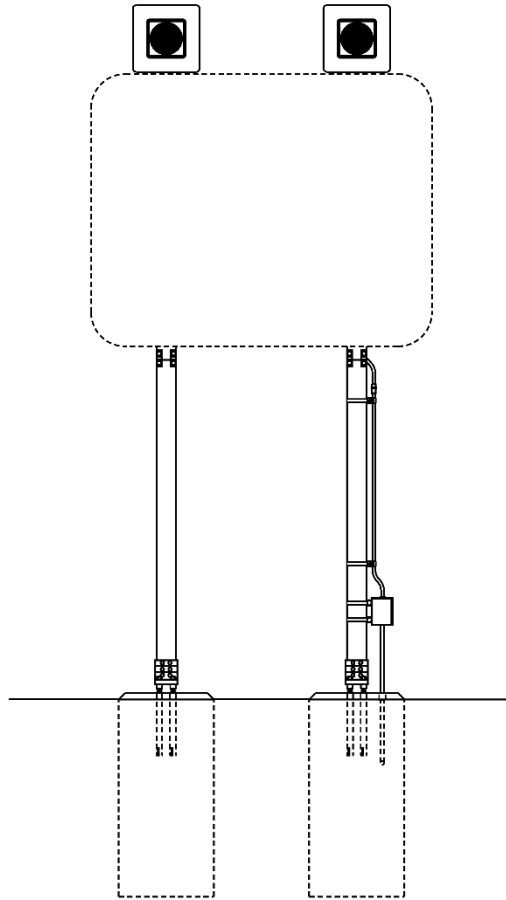

See [Standard Plans](#) G-22.10 (timber post), G-24.60 (steel W-beam post), and J-40.35 (electrical) for installation details.

P2.5(3) Overhead Signal Arm Mounted Sign

Overhead signal arm mounted AWS signs are installed on a Type II signal mast arm, and include:

- A 138" (11'-6") wide by 36" high text warning sign as close to centered as possible over the approach lanes
- Two 12-inch yellow beacons with backplates (no reflective tape), with one on either side of the sign.
- One 48" x 48" W-series warning sign installed near the mast arm attachment point.

Overhead AWS signs mounted on signal standards include a vibration damper, due to the low weight and large surface area of signs and displays. Signal arms are restricted to either a 40-foot or 50-foot mast arm length due to the width of the signs and to manage mast arm deflection. Designers are directed to select the mast arm length that will result in the sign and beacon array being closest to the center of the approach.

Where enhanced visibility is needed, beacons may be installed in pairs (2-section displays) and operate in alternating flash (top-left and bottom-right, then bottom-left and top-right).

Exhibit P2.5-3: Overhead Signal Arm Mounted AWS Sign

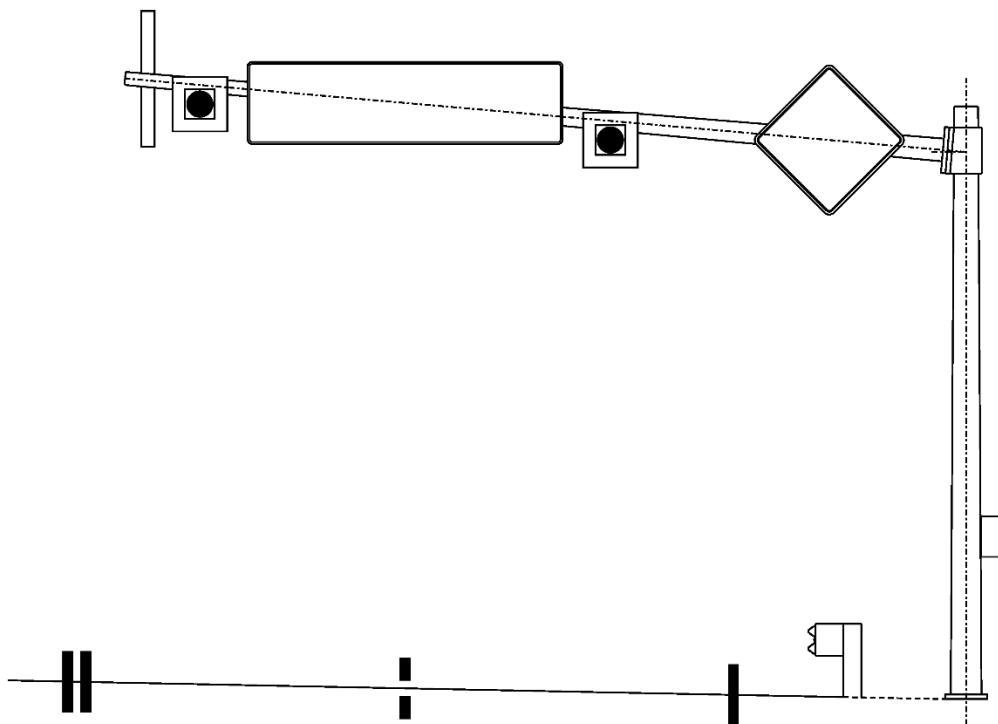

See [Standard Detail IS-13D](#) for installation details.

P2.5(4) Overhead Sign Structure Mounted Sign

Overhead signs installed on sign structures consist of a single large sign that includes both the appropriate W-series sign and a text message. Signs mounted on sign structures shall have two beacons, one installed on the first vertical W-beam support at least two feet in from each end of the sign.

Where enhanced visibility is needed, beacons may be installed in pairs (2-section displays) and operate in alternating flash (top-left and bottom-right, then bottom-left and top-right).

Exhibit P2.5-4: Overhead Sign Structure Mounted AWS Sign (Cantilever structure shown)

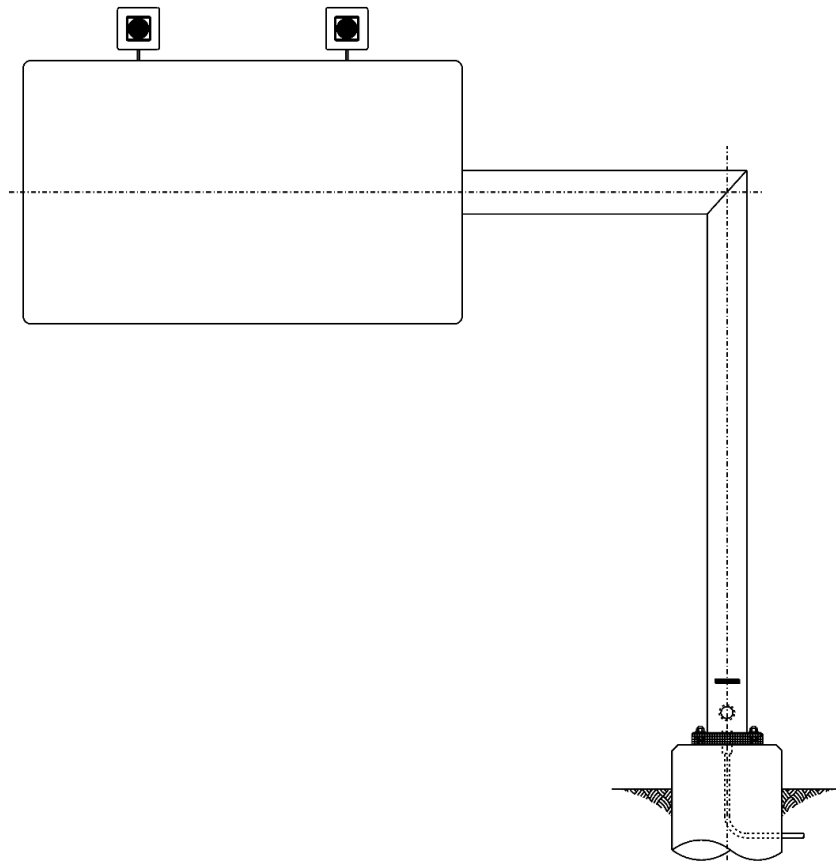

See [Standard Plan J-75.50](#) for installation details.

P2.6 PTSWF Signs

Signs for PTSWF systems are a combination of a W3-3 Signal Ahead Symbol warning sign and a supplemental “BE PREPARED TO STOP WHEN FLASHING” or “PREPARE TO STOP WHEN FLASHING” sign or message. Enhanced and overhead freeway/expressway signs are a single sign that combines these two signs, with the W3-3 sign on a black background on a portion of the sign.

The size, placement, and number of signs is dependent on the number of lanes on the approach. Where a right turn lane is present at the location of the sign(s), it is included in the total number of lanes because traffic in that lane may block visibility of the right-side sign. A left turn lane at the location of the sign(s) is not included in the total number of lanes.

Single lane approaches require a minimum of one ground mounted sign. Gated signs (one sign on each side of the roadway) are recommended where the posted speed is 50 MPH or higher or where the right-side sign may have limited visibility (such as on a curve).

Approaches with two lanes shall use gated signs or overhead signs. Approaches with three or more lanes require overhead signs. Freeways and expressways that end at a traffic signal should use overhead sign structure mounted signs, but may use gated ground mounted signs where the approach is only two lanes with approval from the Region Traffic Engineer.

P2.6(1) Standard PTSWF Signs

Standard PTSWF signs consist of a 48” x 48” W3-3 Signal Ahead (Symbol) sign and a 60” x 36” W3-301P “BE PREPARED TO STOP WHEN FLASHING” plaque.

Exhibit P2.6-1: Standard PTSWF Sign Plaque W3-301P



Where standard signs are used at the end of a freeway or expressway, they shall use a larger 72” x 54” W3-302P “BE PREPARED TO STOP WHEN FLASHING” plaque.

Exhibit P2.6-2: Large PTSWF Sign Plaque W3-302P**P2.6(2) Overhead PTSWF Signs**

Overhead signal arm mounted PTSWF signs shall use a 48" x 48" W3-3 Signal Ahead (Symbol) sign and a 138" x 36" W3-303 "PREPARE TO STOP WHEN FLASHING" sign over the roadway. These signs may not be used over freeways or expressways.

Exhibit P2.6-3: PTSWF Overhead W3-303 Sign**P2.6(3) Overhead PTSWF Signs for Freeways and Expressways**

Overhead PTSWF signs for freeways and expressways shall be sign structure mounted. Overhead PTSWF signs shall not be installed on the same sign structure as any other flashing beacon sign or on the same sign structure as an electronic Variable Message Sign (VMS) of any kind.

Standard overhead signs shall be 216" x 72" W3-304 with an embedded 48" x 48" W3-3 Signal Ahead (Symbol) and "PREPARE TO STOP WHEN FLASHING" text.

Exhibit P2.6-4: PTSWF Overhead W3-304 Freeway/Expressway Sign W3-304



W3-304

Where a narrower sign is required due to space constraints, a taller and narrower 144" x 102" W3-305 sign may be used instead.

Exhibit P2.6-5: PTSWF Overhead W3-304 Freeway/Expressway Narrow Sign W3-305



W3-305

P2.6(4) Enhanced Ground PTSWF Signs

Enhanced ground PTSWF signs use a smaller 120" x 96" version of the W3-305 overhead PTSWF sign.

P2.7 ICWS Major Roadway Signs

Major roadway signing for ICWS will depend on the specific concern(s) being addressed by the system. The size, shape, and mounting of the sign(s) for the major roadway will depend on the posted speed of the major roadway and the number of lanes on that approach at the location of the sign.

Where a right turn lane is present at the location of the sign(s), it is included in the total number of lanes because traffic in that lane may block visibility of the right-side sign. A left turn lane at the location of the sign(s) is not included in the total number of lanes.

Single lane approaches require a minimum of one ground mounted sign. Gated signs (one sign on each side of the roadway) are recommended where the posted speed is 50 MPH or higher or where the right-side sign may have limited visibility (such as on a curve).

Approaches with two lanes shall use gated signs or overhead signs. Approaches with three or more lanes require overhead signs.

Major roadway approaches shall use one of the following warning messages shall be provided, as applicable:

- “WATCH FOR STOPPED TRAFFIC”. Use on the major roadway when the concern is stopped traffic (turning or queue) on the major roadway.
- “WATCH FOR ENTERING TRAFFIC”. Use on the major roadway when the concern is traffic entering or crossing from the minor roadway.
- “WATCH FOR TURNING TRAFFIC”. Use on the major roadway when the concern is oncoming traffic turning from the major roadway onto the minor roadway.

For locations where “WATCH FOR ENTERING TRAFFIC” and “WATCH FOR TURNING TRAFFIC” both apply, use “WATCH FOR TURNING TRAFFIC”, as the turning traffic will be in conflict longer than crossing traffic due to slower speeds while turning, and this sign better addresses two of the three conflicts (traffic turning across lanes, traffic turning into the lane, traffic crossing the lanes).

P2.7(1) Standard ICWS Signs

Where the major roadway has a posted speed of 40 MPH or lower, signs on the major roadway shall be one of the following 48” x 48” W-201 Series warning signs:

- W2-201A “WATCH FOR STOPPED TRAFFIC”
- W2-201B “WATCH FOR ENTERING TRAFFIC”
- W2-201C “WATCH FOR TURNING TRAFFIC”

Exhibit P2.7-1: Major Roadway ICWS Standard Signs – W2-201 Series



P2.7(2) Large ICWS Signs

Where the major roadway has a posted speed of 45 MPH or higher, larger 72" x 48" signs are required. The signs shall be one of the following:

- W2-202A "CAUTION - WATCH FOR STOPPED TRAFFIC"
- W2-202B "CAUTION - WATCH FOR ENTERING TRAFFIC"
- W2-202C "CAUTION - WATCH FOR TURNING TRAFFIC"

Exhibit P2.7-2: Major Roadway ICWS Large Signs – W2-202 Series



P2.7(3) ICWS Sign Plaques

As an alternative to either the W2-201 signs or the W2-202 signs, an appropriate W-series intersection warning sign may be used with one of the following 60" x 36" plaques:

- W2-101P "WATCH FOR STOPPED TRAFFIC"
- W2-102P "WATCH FOR ENTERING TRAFFIC"
- W2-103P "WATCH FOR TURNING TRAFFIC"

Exhibit P2.7-3: Major Roadway ICWS Sign Plaques – W2-10xP Series

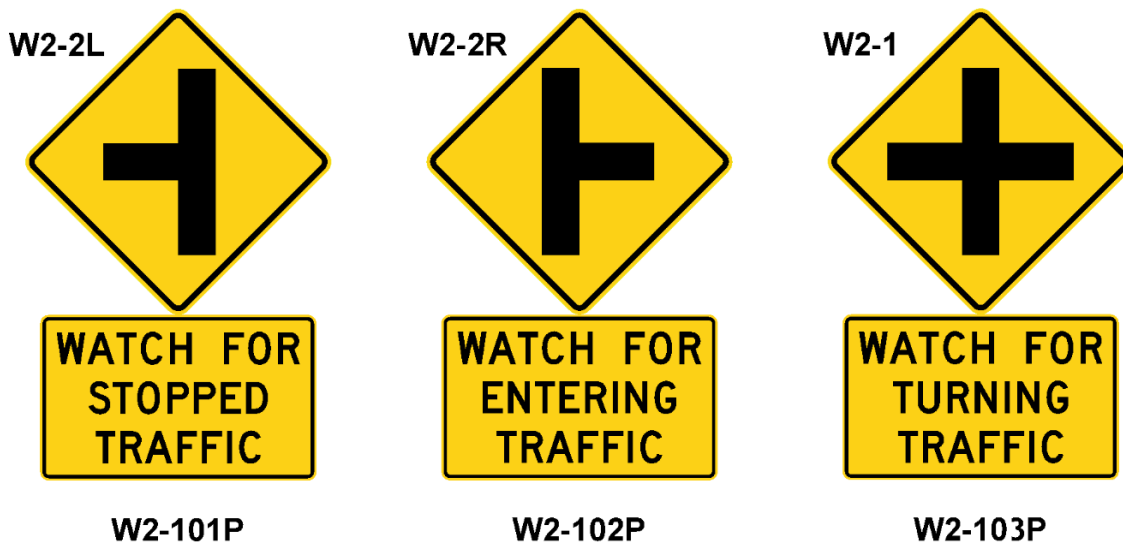

P2.7(4) Overhead ICWS Signs

Overhead signal arm mounted signs shall use the appropriate W-series intersection warning sign and one of the following 138" x 36" overhead warning signs over the roadway:

- W2-204A "WATCH FOR STOPPED TRAFFIC"
- W2-204B "WATCH FOR ENTERING TRAFFIC"
- W2-204C "WATCH FOR TURNING TRAFFIC"

Exhibit P2.7-4: Major Roadway ICWS Overhead Signs - W2-203 Series



P2.7(5) Enhanced ICWS Signs

Enhanced signs may be used where a larger sign, greater emphasis, or stronger background contrast is needed. These signs are a larger 120" x 96" single sign with a black background for the W-series sign:

- W2-204A "WATCH FOR STOPPED TRAFFIC"
- W2-204B "WATCH FOR ENTERING TRAFFIC"
- W2-204C "WATCH FOR TURNING TRAFFIC"

Exhibit P2.7-5: Major Roadway ICWS Enhanced Signs – W2-204 Series



For enhanced signs installed on an overhead sign structure, they shall use a modified version of the W3-304 or W3-305 sign with the appropriate W-series sign and text.

P2.8 ICWS Minor Roadway Signs

For warning signs on the minor roadway, use a 48" x 48" W2-201 "WATCH FOR APPROACHING TRAFFIC". Use on the minor roadway when the concern is traffic approaching on the major roadway.

Exhibit P2.8-1: Minor Roadway ICWS Sign W2-201



W2-201

P2.9 RCWS Signs

Signs for RCWS shall consist of a primary W-series sign, and may include an optional 60" x 36" W2-101P "WATCH FOR STOPPED TRAFFIC" plaque. The primary W series sign shall be one of the following, as appropriate:

- W10-1 Railroad Crossing Warning Sign, 48"
- W10-2L/R Crossroad with Rail Crossing Warning Sign, 48" x 48"
- W10-3L/R Side Road with Rail Crossing Warning Sign, 48" x 48"

Exhibit P2.9-1: Basic RCWS Sign and Plaque

W10-1



W2-101P

Overhead RCWS signs shall use the appropriate W-series railroad warning sign and a W2-203A sign as described in Section P2.7(4) for overhead ICWS signs. Enhanced RCWS signs shall use a

W2-204A sign with appropriate W-series railroad warning sign as described in Section P2.7(5) for enhanced ICWS signs.

P2.10 Operation

The operation of an AWS depends on the type of AWS.

P2.10(1) PTSWF Operation

PTSWF systems are designed to start flashing before the start of the Yellow Change Interval and remain flashing until the start of the next green phase. The amount of time the system flashes before the Yellow Change Interval starts is determined by Equation P2-10-1:

$$AWT = \frac{D + D_P}{1.47V_{85}} \quad \text{Equation (P2.10-1)}$$

Where:

- AWT = Advance Warning Time, in seconds.
- D = Distance to the stop line, in feet;
Measured from where the PTSWF sign is located.
- $D_P = 70$; PTSWF minimum sign perception distance, in feet.
- $V_{85} = 85^{\text{th}}$ Percentile Speed, in mph;
If 85^{th} percentile speed is not known, use posted speed plus 7 mph. (See Reference 4)

The system shall also flash if the associated traffic signal system goes into flash if the system can support this operation. The PTSWF beacons shall always flash alternately.

For convenience, typical Advance Warning Times are shown in the tables in Section P2.11.

P2.10(2) ICWS Operation

ICWS are designed to flash at any time there is a potential conflicting vehicle that cannot be seen by a driver approaching from a different roadway. Flashing operations will depend on the approach to which the warning applies.

P2.10(2)(a) Major Roadway Warnings

For systems providing warning to traffic on the major roadway, the flashing operation timing depends on the minor roadway movement of concern.

For Cross Traffic, Turning Traffic, or Stopped Traffic, the system shall flash any time a vehicle is within the detection zone.

For Entering Traffic, at a minimum, system shall flash any time a vehicle is within the detection zone. Consider extending flash timing to address vehicle acceleration up to a certain speed, which may be more desirable in locations with acceleration issues or higher entering truck volumes.

Table P2.10-1; Extended Warning Times for Accelerating Traffic

Posted Speed (MPH)	Merge Speed (MPH)	Extended Warning Time, Trucks Allowed (seconds)	Extended Warning Time, Trucks Prohibited (seconds)
35	27	25	10
40	31	29	11
45	35	33	12
50	39	36	14
55	43	40	15
60	47	44	16

Extended warning times are based on the following kinematic formula:

$$EWT = \frac{1.47V_M}{a} \quad \text{Equation (P2.10-2)}$$

Where:

- EWT = Extended Warning Time, in seconds.
- V_M = Merge Speed, in mph;

This is the Merge Speed as defined in AASHTO Green Book Table 10-4, and is used as a reasonable approximation of a speed at which the vehicle is sufficiently close to the roadway operating speed.

- $a = 1.6$ or 4.4 ; acceleration rate, in feet / seconds²;

Use $a = 1.6$ unless trucks are prohibited on the approach. (See Reference 14)

For entering traffic which immediately must start uphill, EWT for truck traffic can be extended by a factor of 1.3 for upgrades of 3-4% or by a factor of 1.5 for upgrades of 5% or more.

In locations where both cross traffic and entering traffic is a concern, use the longest applicable extended warning time for entering traffic.

P2.10(2)(b) Minor Roadway Warnings

For systems providing warning to traffic on the minor roadway, the system shall flash for the entire time that a vehicle is in the detection zone.

For continuous type detection systems, where the sensor can detect a vehicle for the entire length of the detection zone, no additional timing is required as the sensor will maintain the system active as long as any vehicle is within the detection zone.

For trigger type detection systems, the system must be timed based on how long it takes a vehicle to travel from the trigger point to the near edge line of the minor street roadway. This timing is calculated using equation P2.10-3 below.

$$CWT = \frac{D_D}{1.47V} \quad \text{Equation (P2.10-3)}$$

Where:

- CWT = Conflict Warning Time, in seconds.
- D_D = Detection zone length, in feet. Calculated in Equation P2.10-3.
- V = Posted Speed, in mph;

P2.10(3) RCWS Operation

RCWS are designed to flash at any time the rail crossing signals are active. RCWS are connected to the rail crossing system and activate at the same time as the rail crossing flashing lights. Operation continues until the rail crossing light operation is complete.

A 24 VDC (new systems) or 120 VAC (existing systems) circuit is provided at the electrical service cabinet. Verify with the railroad if they require 24 VDC or 120 VAC for connection to their relay. This circuit is connected to a relay in the railroad bungalow and powers a second relay for the flashing beacon system located at the electrical service cabinet.

Exhibit P2.10-2: Basic RCWS Circuit Design (24 VDC RR Circuit Shown)

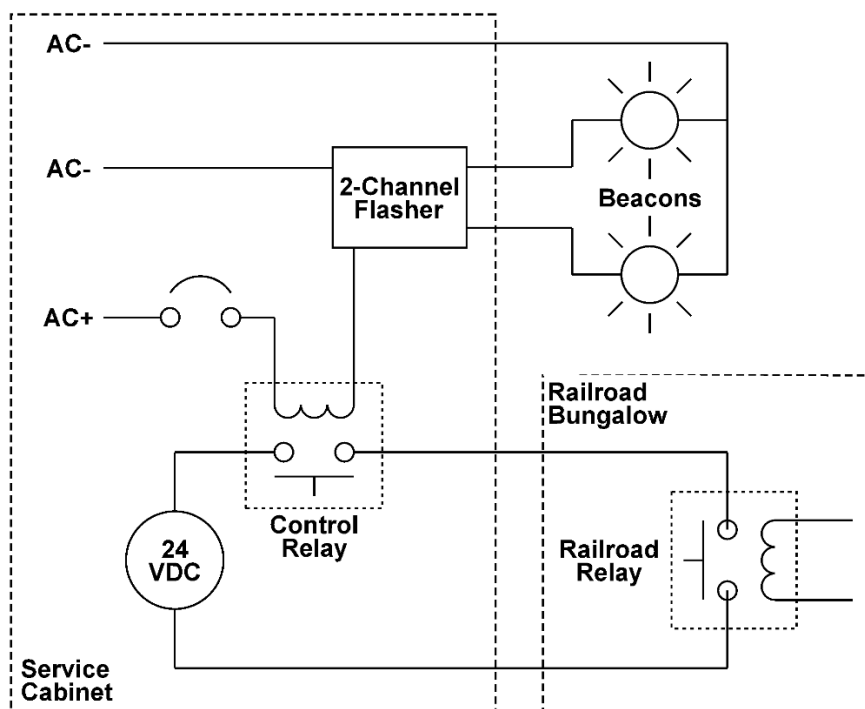

P2.11 Quick Reference Tables

The following tables are provided as a quick reference guide for the following items:

- AWS sign placements (D_s)
- ICWS major roadway detection zone lengths (D_D)
- PTSWF Advance Warning Times (AWT)

These values are for basic grades and posted speeds **where the 85th percentile speed is not known**. Where the 85th percentile speed is known, these must be calculated as described in Sections P2.4(1), P2.4(3)(a), and P2.10(1).

Tables P2.11-1A through P2.11-1D are for locations where trucks are allowed, and tables P2.11-2A through P2.11-2D are for locations where trucks are prohibited.

P2.11(1) Quick Reference Tables – Approaches with Trucks

Tables P2.11-1A through P2.11-1D list sign placements, ICWS detection zone lengths, and PTSWF Advance Warning Times (PTSWF) for locations where trucks are allowed and use a deceleration rate of $t = 8 \text{ ft/s}^2$.

Table P2.11-1A; 45 MPH Roadway, Trucks Allowed ($a = 8 \text{ ft/s}^2$)

Grade	ICWS/RCWS Sign Placement (D_s , feet)	PTSWF Sign Placement (D_s)/ ICWS Detection Zone Length (D_D) (feet)	PTSWF Advance Warning Time (AWT, seconds)
-8% Downgrade	550	730	8.2
-7% Downgrade	520	700	7.8
-6% Downgrade	490	670	7.4
-5% Downgrade	470	650	7.1
-4% Downgrade	445	625	6.8
-3% Downgrade	425	605	6.5
-2% Downgrade	410	590	6.3
-1% Downgrade	390	570	6.1
0% Flat	375	555	5.9
1% Upgrade	360	540	5.7
2% Upgrade	350	530	5.5
3% Upgrade	335	515	5.3
4% Upgrade	325	505	5.2
5% Upgrade	315	495	5.1
6% Upgrade	305	485	5.0
7% Upgrade	295	475	4.8
8% Upgrade	290	470	4.8

Table P2.11-1B; 50 MPH Roadway, Trucks Allowed ($a = 8 \text{ ft/s}^2$)

Grade	ICWS/RCWS Sign Placement (D_s , feet)	PTSWF Sign Placement (D_s)/ ICWS Detection Zone Length (D_D) (feet)	PTSWF Advance Warning Time (AWT, seconds)
-8% Downgrade	675	855	8.9
-7% Downgrade	640	820	8.5
-6% Downgrade	605	785	8.1
-5% Downgrade	580	760	7.8
-4% Downgrade	550	730	7.4
-3% Downgrade	530	710	7.2
-2% Downgrade	505	685	6.9
-1% Downgrade	485	665	6.7
0% Flat	470	650	6.5
1% Upgrade	450	630	6.3
2% Upgrade	435	615	6.1
3% Upgrade	420	600	5.9
4% Upgrade	405	585	5.7
5% Upgrade	395	575	5.6
6% Upgrade	385	565	5.5
7% Upgrade	370	550	5.3
8% Upgrade	360	540	5.2

Table P2.11-1C; 55 MPH Roadway, Trucks Allowed ($a = 8 \text{ ft/s}^2$)

Grade	ICWS/RCWS Sign Placement (D_s , feet)	PTSWF Sign Placement (D_s)/ ICWS Detection Zone Length (D_D) (feet)	PTSWF Advance Warning Time (AWT, seconds)
-8% Downgrade	810	990	9.7
-7% Downgrade	770	950	9.3
-6% Downgrade	730	910	8.8
-5% Downgrade	695	875	8.4
-4% Downgrade	665	845	8.1
-3% Downgrade	635	815	7.8
-2% Downgrade	610	790	7.5
-1% Downgrade	590	770	7.3
0% Flat	565	745	7.0
1% Upgrade	545	725	6.8
2% Upgrade	530	710	6.6
3% Upgrade	510	690	6.4
4% Upgrade	495	675	6.2
5% Upgrade	480	660	6.1
6% Upgrade	465	645	5.9
7% Upgrade	455	635	5.8
8% Upgrade	440	620	5.6

Table P2.11-1D; 60 MPH Roadway, Trucks Allowed ($a = 8 \text{ ft/s}^2$)

Grade	ICWS/RCWS Sign Placement (D_s , feet)	PTSWF Sign Placement (D_s)/ ICWS Detection Zone Length (D_D) (feet)	PTSWF Advance Warning Time (AWT, seconds)
-8% Downgrade	955	1135	10.5
-7% Downgrade	905	1085	9.9
-6% Downgrade	865	1045	9.5
-5% Downgrade	825	1005	9.1
-4% Downgrade	785	965	8.7
-3% Downgrade	755	935	8.4
-2% Downgrade	725	905	8.1
-1% Downgrade	695	875	7.8
0% Flat	670	850	7.6
1% Upgrade	650	830	7.4
2% Upgrade	625	805	7.1
3% Upgrade	605	785	6.9
4% Upgrade	585	765	6.7
5% Upgrade	570	750	6.5
6% Upgrade	555	735	6.4
7% Upgrade	540	720	6.2
8% Upgrade	525	705	6.1

P2.11(2) Quick Reference Tables – Approaches with no Trucks

Tables P2.11-2A through P2.11-2D list sign placements, ICWS detection zone lengths, and PTSWF Advance Warning Times (PTSWF) for locations where trucks are prohibited and use a deceleration rate of $t = 10 \text{ ft/s}^2$.

Table P2.11-2A; 45 MPH Roadway, Trucks Prohibited ($a = 10 \text{ ft/s}^2$)

Grade	ICWS/RCWS Sign Placement (D_s , feet)	PTSWF Sign Placement (D_s)/ ICWS Detection Zone Length (D_D) (feet)	PTSWF Advance Warning Time (AWT, seconds)
-8% Downgrade	405	585	6.3
-7% Downgrade	390	570	6.1
-6% Downgrade	375	555	5.9
-5% Downgrade	360	540	5.7
-4% Downgrade	345	525	5.5
-3% Downgrade	335	515	5.3
-2% Downgrade	325	505	5.2
-1% Downgrade	315	495	5.1
0% Flat	305	485	5.0
1% Upgrade	295	475	4.8
2% Upgrade	285	465	4.7
3% Upgrade	280	460	4.6
4% Upgrade	270	450	4.5
5% Upgrade	265	445	4.4
6% Upgrade	255	435	4.3
7% Upgrade	250	430	4.2
8% Upgrade	245	425	4.2

Table P2.11-2B; 50 MPH Roadway, Trucks Prohibited ($a = 10 \text{ ft/s}^2$)

Grade	ICWS/RCWS Sign Placement (D_s , feet)	PTSWF Sign Placement (D_s)/ ICWS Detection Zone Length (D_D) (feet)	PTSWF Advance Warning Time (AWT, seconds)
-8% Downgrade	500	680	6.9
-7% Downgrade	480	660	6.6
-6% Downgrade	465	645	6.4
-5% Downgrade	450	630	6.3
-4% Downgrade	430	610	6.0
-3% Downgrade	420	600	5.9
-2% Downgrade	405	585	5.7
-1% Downgrade	390	570	5.5
0% Flat	380	560	5.4
1% Upgrade	370	550	5.3
2% Upgrade	360	540	5.2
3% Upgrade	350	530	5.1
4% Upgrade	340	520	4.9
5% Upgrade	330	510	4.8
6% Upgrade	325	505	4.8
7% Upgrade	315	495	4.6
8% Upgrade	310	490	4.6

Table P2.11-2C; 55 MPH Roadway, Trucks Prohibited ($a = 10 \text{ ft/s}^2$)

Grade	ICWS/RCWS Sign Placement (D_s , feet)	PTSWF Sign Placement (D_s)/ ICWS Detection Zone Length (D_D) (feet)	PTSWF Advance Warning Time (AWT, seconds)
-8% Downgrade	605	785	7.5
-7% Downgrade	585	765	7.2
-6% Downgrade	560	740	7.0
-5% Downgrade	540	720	6.7
-4% Downgrade	525	705	6.6
-3% Downgrade	505	685	6.4
-2% Downgrade	490	670	6.2
-1% Downgrade	475	655	6.0
0% Flat	465	645	5.9
1% Upgrade	450	630	5.8
2% Upgrade	440	620	5.6
3% Upgrade	425	605	5.5
4% Upgrade	415	595	5.4
5% Upgrade	405	585	5.3
6% Upgrade	395	575	5.2
7% Upgrade	385	565	5.0
8% Upgrade	380	560	5.0

Table P2.11-2D; 60 MPH Roadway, Trucks Prohibited ($a = 10 \text{ ft/s}^2$)

Grade	ICWS/RCWS Sign Placement (D_s , feet)	PTSWF Sign Placement (D_s)/ ICWS Detection Zone Length (D_D) (feet)	PTSWF Advance Warning Time (AWT, seconds)
-8% Downgrade	720	900	8.1
-7% Downgrade	690	870	7.8
-6% Downgrade	665	845	7.5
-5% Downgrade	645	825	7.3
-4% Downgrade	620	800	7.1
-3% Downgrade	600	780	6.9
-2% Downgrade	585	765	6.7
-1% Downgrade	565	745	6.5
0% Flat	550	730	6.3
1% Upgrade	535	715	6.2
2% Upgrade	520	700	6.0
3% Upgrade	510	690	5.9
4% Upgrade	495	675	5.8
5% Upgrade	485	665	5.7
6% Upgrade	475	655	5.6
7% Upgrade	460	640	5.4
8% Upgrade	450	630	5.3

P2.12 References

The following references are used in the development of this chapter:

1. B.A. Farragher, R. Weinholzer and M.P. Kowski, "The Effect of Advanced Warning Flashers on red-light Running-A Study Using Motion Imaging Recording System Technology at Trunk Highway 169 and Pioneer Trail in Bloomington, Minnesota."
2. British Columbia Ministry of Transportation and Infrastructure, Electrical and Traffic Engineering Manual (2013), Section 402.6.9
(http://www.th.gov.bc.ca/publications/eng_publications/electrical/electrical_and_traffic_eng/Electrical_Signing_Design_Manual/tableofcontents.htm)
3. Donnell, ET, ML Adolini, DJ Torbic, JM Mason, & Lily Elefteriadou. "Truck Safety Considerations for Geometric Design and Traffic Operations." Proceedings of the ITE 2001 Annual Meeting and Exhibit, Chicago, IL: 2001.
(https://nacto.org/docs/usdg/truck_safety_considerations_for_geometric_design_and_traffic_operations_donnell.pdf)
4. Minnesota DOT (MnDOT) Traffic Signal Timing and Coordination Manual, 2019, Section 4.13: Guidelines for Consideration and Timing of Advanced Warning Flashers;
<http://www.dot.state.mn.us/trafficeng/signals/manual.html>
5. Minnesota Manual on Uniform Traffic Control Devices (MN MUTCD) (2018), Chapter 40, Advance Warning Flashers (<http://www.dot.state.mn.us/trafficeng/publ/mutcd/>)
6. NCHRP Report 505 – Review of Truck Characteristics as Factors in Roadway Design, Transportation Research Board, Washington, DC, 2003
(<http://www.trb.org/Publications/Blurbs/153579.aspx>)
7. NCHRP Report 731 – Guidelines for Timing Yellow and All Red Intervals at Signalized Intersections, Transportation Research Board, Washington, DC, 2013
(<http://www.trb.org/Publications/Blurbs/168017.aspx>)
8. Ohio Department of Transportation (ODOT) Traffic Engineering Manual (2018), Section 407-2 Prepare to Stop When Flashing Signs (W3-H4a)
(<http://www.dot.state.oh.us/Divisions/Engineering/Roadway/DesignStandards/traffic/TEM/Pages/default.aspx>)
9. P. D. Pant, X. H. Huang. "Active Advance Warning Signs at High-Speed Signalized Intersections: Results of a Study in Ohio," Transportation Research Record, no. 1368 (1992): 18-26. (<http://onlinepubs.trb.org/Onlinepubs/trr/1992/1368/1368-003.pdf>)
10. T. Sayed, H. Vahidi, and F. Rodriguez, "Advanced Warning Flashers: Do They Improve Safety?" Transportation Research Record 1692, (Washington, DC: Transportation Research Board, 1999). (<https://trrjournalonline.trb.org/doi/abs/10.3141/1692-05>)

11. TTI Report FHWA/TX-04/0-4260-2, Design and Installation Guidelines for Advance Warning Systems for End-of-Green Phase at High Speed Traffic Signals (2003)
(<https://tti.tamu.edu/publications/catalog/record/?id=9128>)
12. TTI Report FHWA/TX-04/0-4260-4, Development of Advance Warning Systems for End-of-Green Phase at High Speed Traffic Signals (2004)
(<https://tti.tamu.edu/publications/catalog/record/?id=9130>)
13. Virginia DOT Traffic Engineering Instructional and Informational Memorandum TE-348, Traffic Signal Controller Actuated Warning Beacons, May 2007
(http://www.viriniadot.org/business/traffic_engineering_memoranda.asp)
14. Minnesota DOT (MnDOT) Traffic Signal Timing and Coordination Manual, 2019, Appendix A: Glossary of Signal Timing Terms;
(<http://www.dot.state.mn.us/trafficeng/signals/manual.html>)

P2.13 Sign Fabrication Details

W2-101P	ICWS Standard Plaque
W2-201	ICWS Standard Warning Sign
W2-202A	ICWS Large Warning Sign
W2-203A	ICWS Overhead Warning Sign
W2-204A	ICWS Enhanced Warning Sign
W3-301P	PTSWF Standard Plaque
W3-302P	PTSWF Large Plaque
W3-303	PTSWF Overhead Freeway Sign
W3-304	PTSWF Overhead Freeway Narrow Sign
W3-305	PTSWF Enhanced Sign

W2-101P

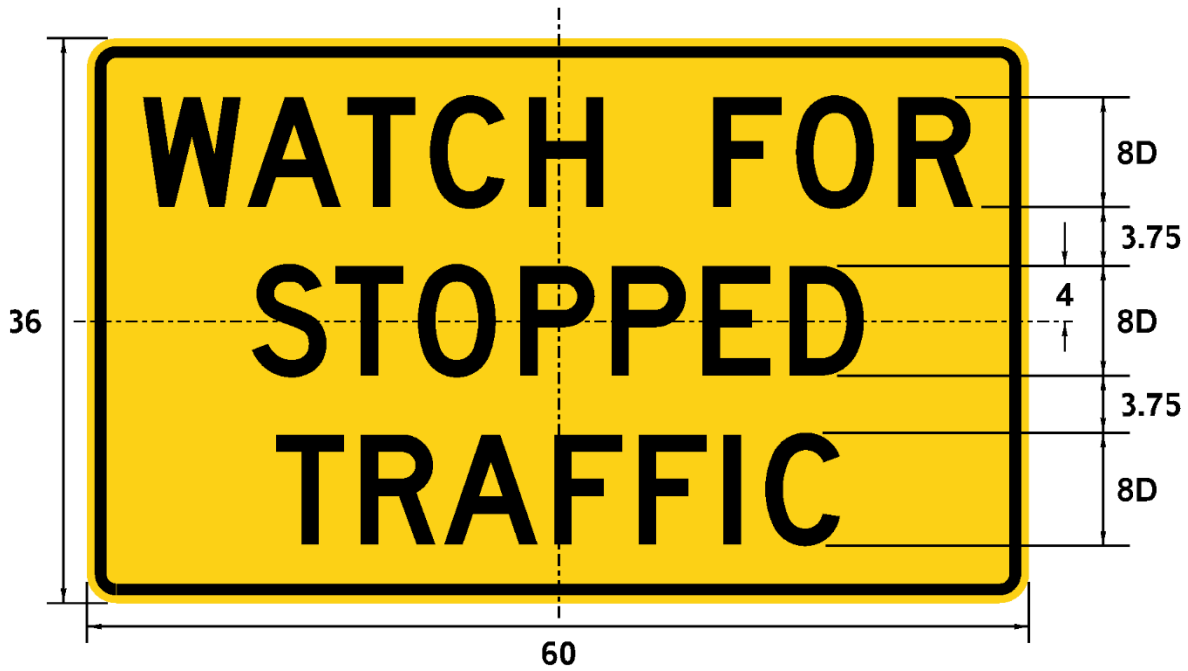

W2-102P



W2-103P

Colors:

- Legend: Black
- Background: Yellow (retroreflective)

All dimensions in inches.

W2-201

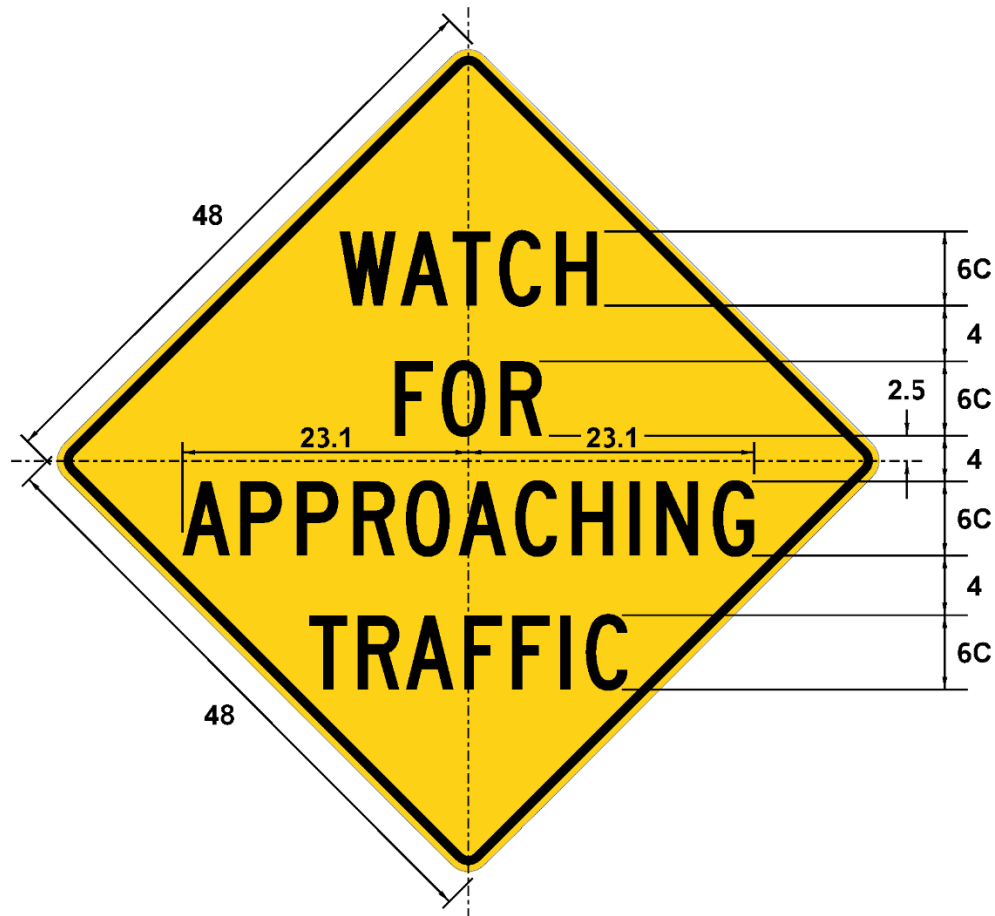

W2-201A



W2-201B



W2-201C

Colors:

- Legend: Black
- Background: Yellow (retroreflective)

All dimensions in inches.

W2-202A



W2-202B



W2-202C

Colors:

- Legend: Black
- Background: Yellow (retroreflective)

All dimensions in inches.

W2-203A

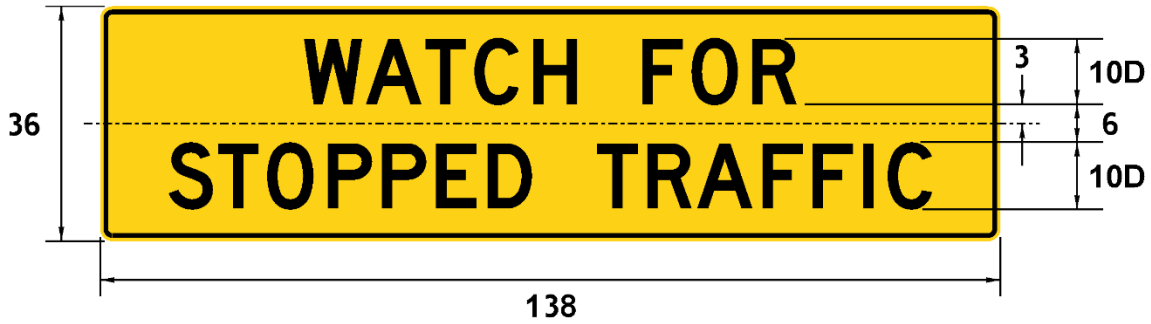

W2-203B



W2-203C

Colors:

- Legend: Black
- Background: Yellow (retroreflective)

All dimensions in inches.

W2-204A

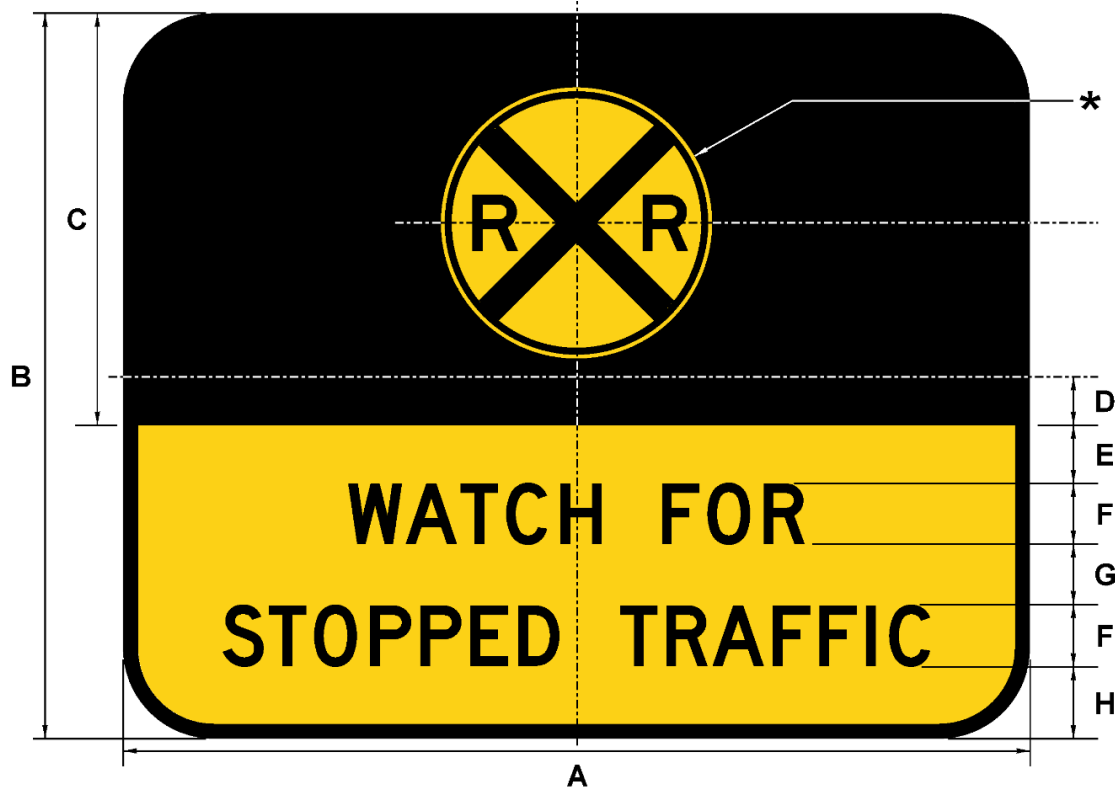

W2-204B



W2-204C

A	B	C	D	E	F	G	H	*
120	96	54	6	9	8D	8	9	36 X 36
144	102	54	3	9	10D	9	10	48 X 48

Colors:

- Legend: Black
- Background: Yellow (retroreflective)

All dimensions in inches.

W3-301P

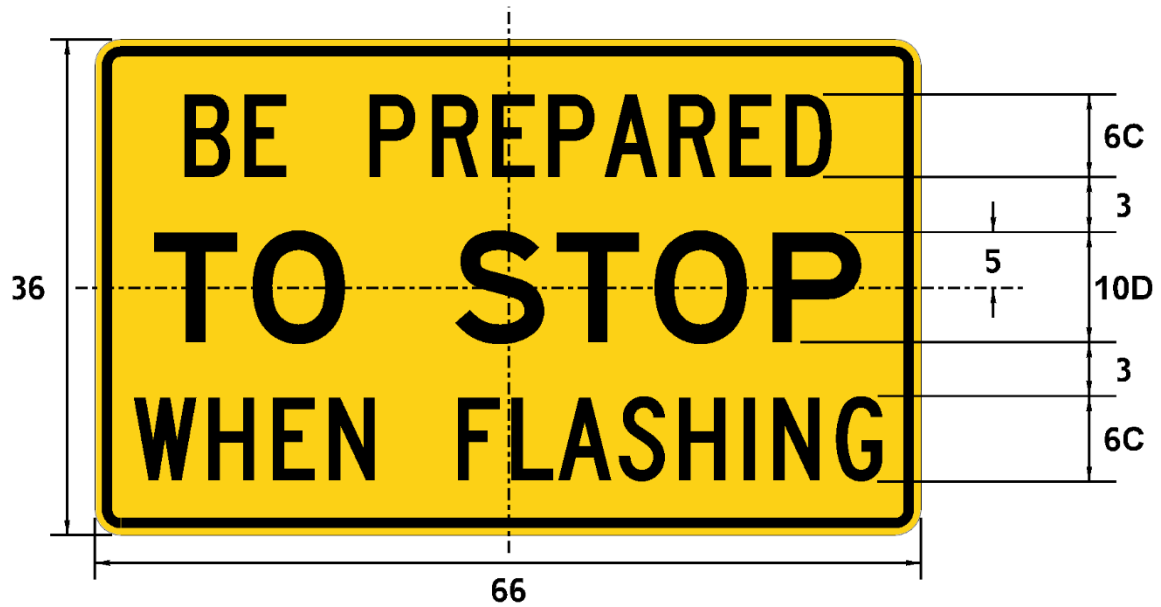

Colors:

- Legend: Black
- Background: Yellow (retroreflective)

All dimensions in inches.

W3-302P



Colors:

- Legend: Black
- Background: Yellow (retroreflective)

All dimensions in inches.

W3-303

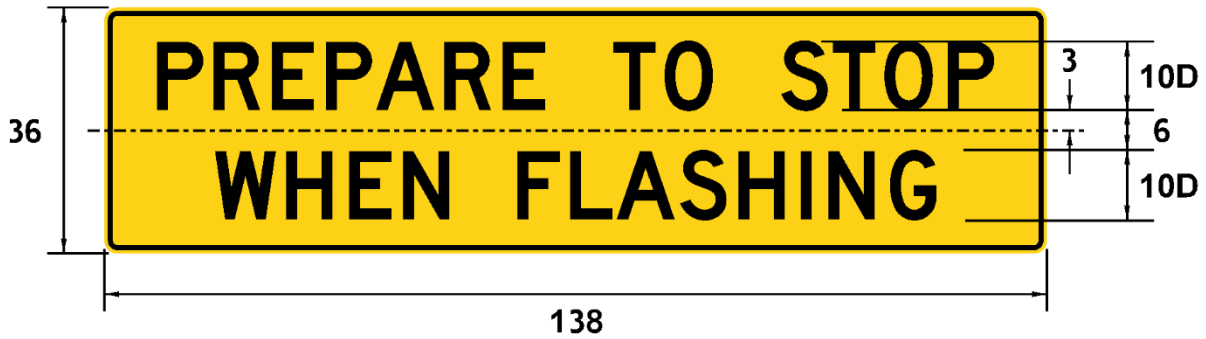

Colors:

- Legend: Black
- Background: Yellow (retroreflective)

All dimensions in inches.

W3-304

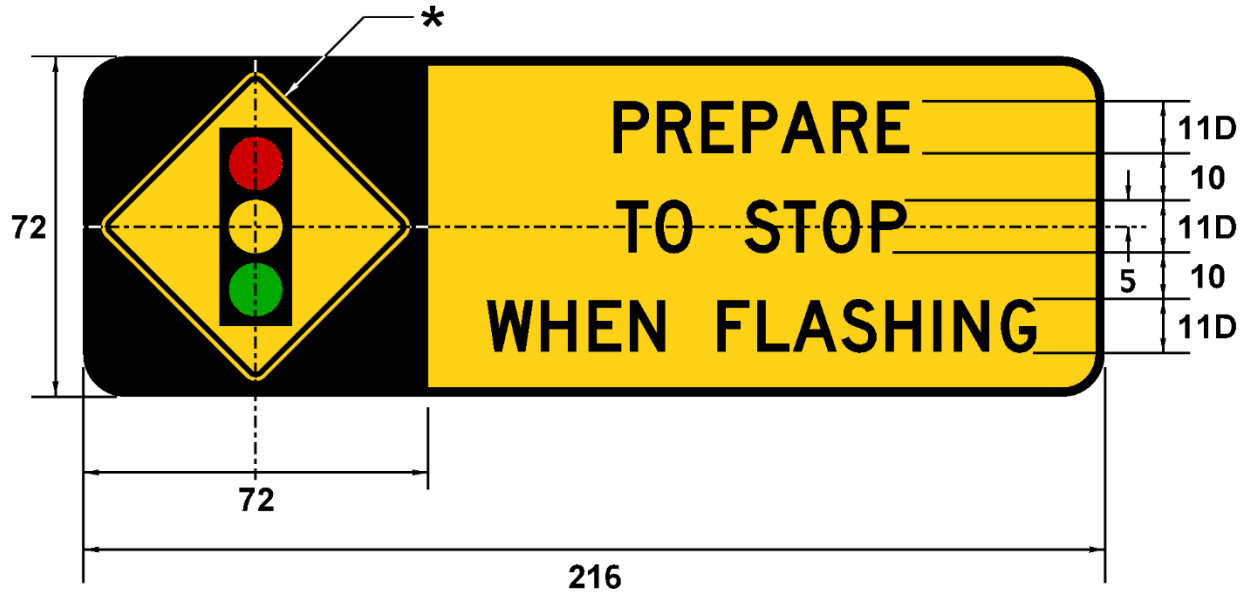

Colors:

- Legend: Black
- Background: Yellow (retroreflective)

All dimensions in inches.

W3-305

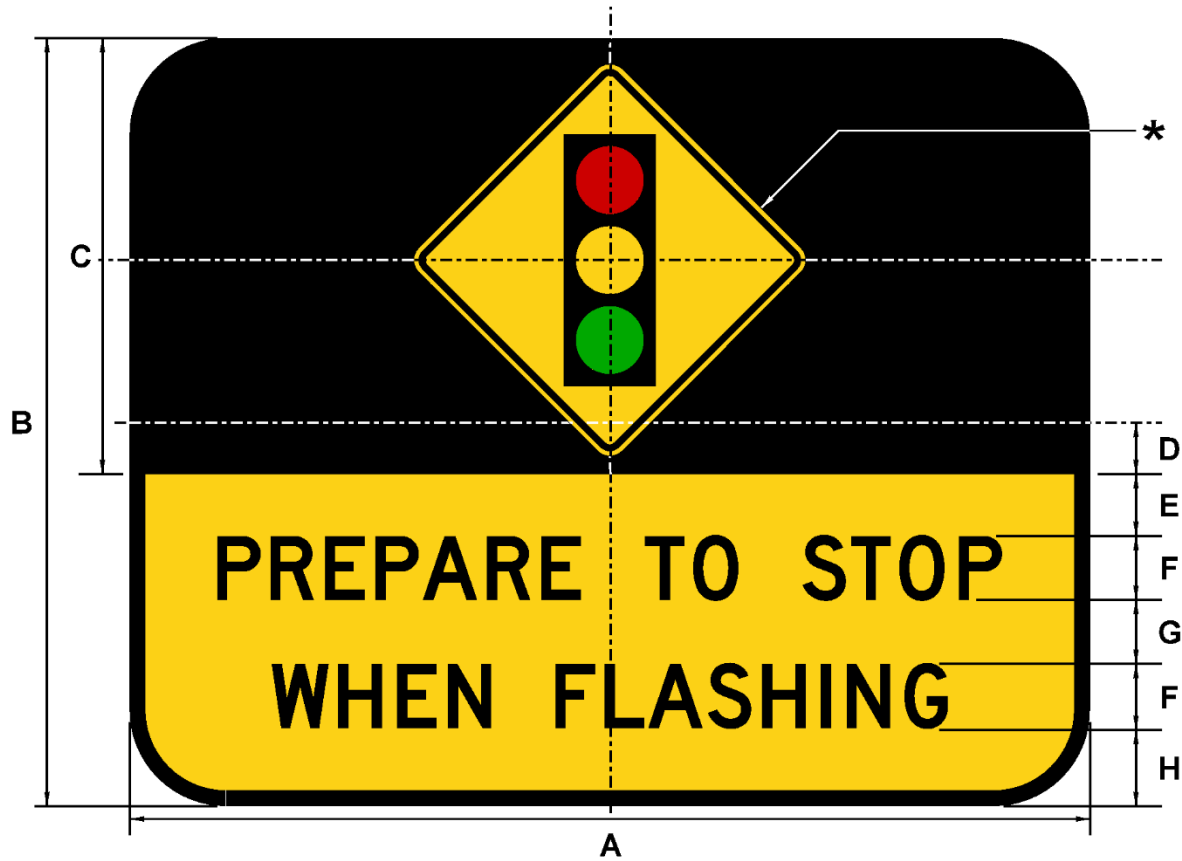

A	B	C	D	E	F	G	H	*
120	96	54	6	9	8D	8	9	36 X 36
144	102	54	3	9	10D	9	10	48 X 48

Colors:

- Legend: Black
- Background: Yellow (retroreflective)

All dimensions in inches.