

DRAWN BY: LISA CYFORD

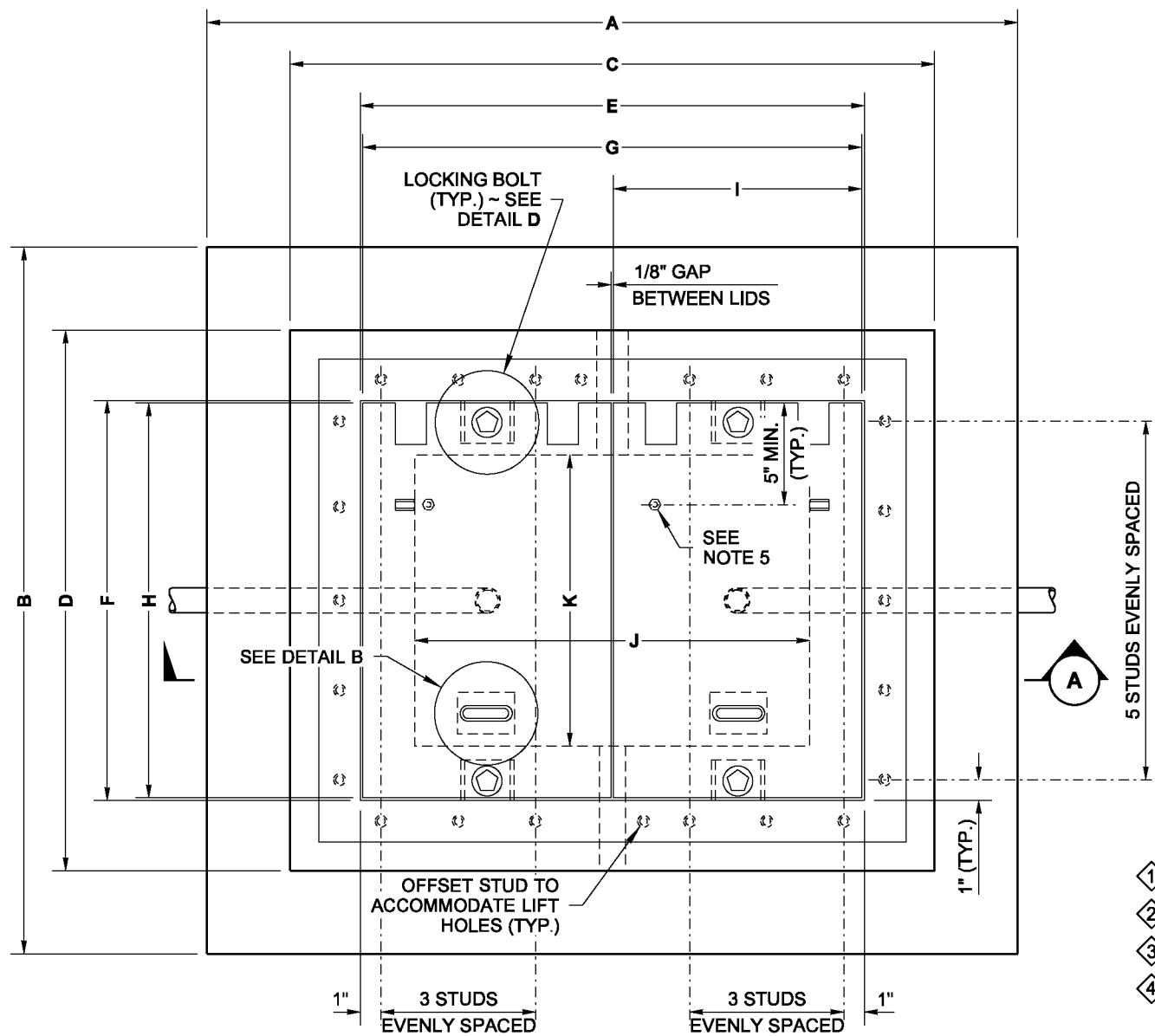

JUNCTION BOX DIMENSION TABLE				
MARK	ITEM	BOX TYPE		
		TYPE 4	TYPE 5	TYPE 6
A	OVERALL LENGTH	39"	48"	56"
B	OVERALL WIDTH	34"	37"	44"
C	JUNCTION BOX LENGTH	31"	40"	48"
D	JUNCTION BOX WIDTH	26"	29"	36"
E	LID OPENING LENGTH	24"	33 1/8"	41 1/8"
F	LID OPENING WIDTH	19"	22 1/8"	29 1/4"
G	TYPE 4 LID LENGTH	24"	—	—
H	TYPE 4, 5 & 6 LID WIDTH	19"	21 7/8"	29"
I	TYPE 5 & 6 LID LENGTH	—	16 3/8"	20 3/8"
J	INSIDE BOX LENGTH	19"	28"	36"
K	INSIDE BOX WIDTH	14"	17"	24"
X	STIFFENER SPACING	VARIABLES	VARIABLES	VARIABLES
Y	STIFFENER SPACING	VARIABLES	VARIABLES	VARIABLES
Z	STIFFENER LENGTH	18 1/4"	21 1/8"	28 1/4"
CAPACITY ~ CONDUIT DIAM.		6"	12"	24"

**NOTES**

- All box dimensions are approximate. Exact configurations vary among manufacturers.
- All lid thicknesses are minimum.
- Lid perimeter shall bear on frame. Mill to bearing seat and lid perimeter for full even contact after fabrication of frame and lid. Lid and frame units with uneven bearing will be rejected.
- The installed lid and frame shall fit with full even contact around the perimeter of a junction box after installation. Care shall be taken to prevent debris accumulation on the contact surfaces.
- A 1/4-20 NC x 1" (in) S. S. ground stud shall be welded to the bottom of each lid: include (2) each S. S. nuts and (3) each S. S. flat washers.
- The hinges shall allow the lids to open 180°. When lid assembly is Ductile Iron (Alternative) and equipped with Safety Bars, lids shall open 110°.
- Bolts and nuts shall be liberally coated with anti-seize compound.
- Connect Equipment Bonding Jumper to ground stud on lid. As an alternative to ground stud connection, the Equipment Bonding Jumper shall be attached to the front face of the hinge pocket with a 5/16-20 NC x 1" (in) S. S. bolt, (2) each S. S. nuts, and (3) each S. S. flat washers. Equipment bonding jumper shall be #8 AWG min. x 4' (ft) of tinned braided copper.
- The System Identification letters shall be 1/8" (in) line thickness formed by a mild steel weld bead. See Cover Marking details. Grind off diamond pattern before forming letters. Ductile iron lid lettering shall be recessed, 1/8" (in) line thickness. See **Standard Specification 9-29.2(4)** for details.
- See **Standard Specification 9-29.2(1)B** for class of concrete.
- Unless otherwise noted in the plans or approved by the Engineer, Junction Boxes, Cable Vaults, and Pull Boxes shall not be placed within the traveled way or paved shoulders. All Junction Boxes, Cable Vaults, and Pull Boxes placed within the traveled way or paved shoulders shall be Heavy-Duty. Heavy-Duty Junction Boxes shall not be installed in sidewalks, walkways, and shared use paths.
- Distance between the top of the conduit and the bottom of the Junction Box lid shall be 6" (in) min. to 8" (in) max., for final grade of new construction only. See **Standard Specification 8-20.3(5)**. Where adjustments are to be made to existing Junction Boxes, or for interim construction stages during the contract, the limits shall be from 6" min. to 10" (in) max. See **Standard Specification 8-20.3(6)**.
- Junction Box Types 4, 5, or 6 may be equipped with Ductile Iron (Alternative) Lid(s) and a Cast Iron (Alternative) Frame. Junction box shall meet the requirements of **Standard Specification 9-29.2** and shall be in accordance with approved shop drawings.

- ① Equipment Grounding Conductor
- ② Copper Solderless Crimp Connector
- ③ Equipment Bonding Jumper (See Note 8)
- ④ See Contract Plans and Special Provisions for conduit size and number

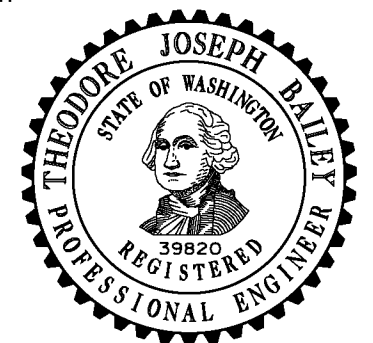
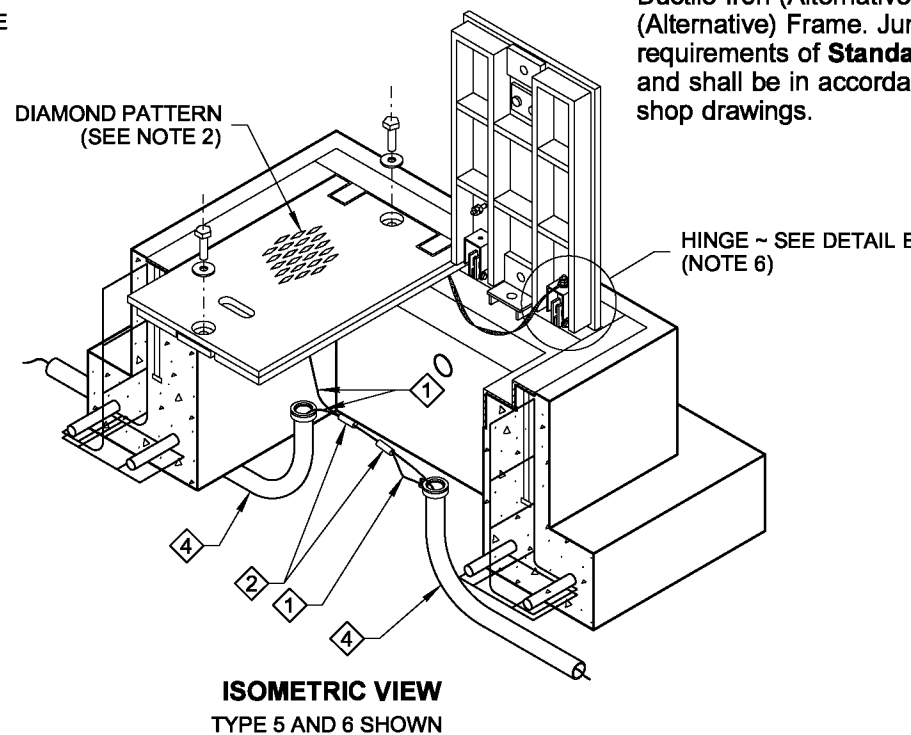
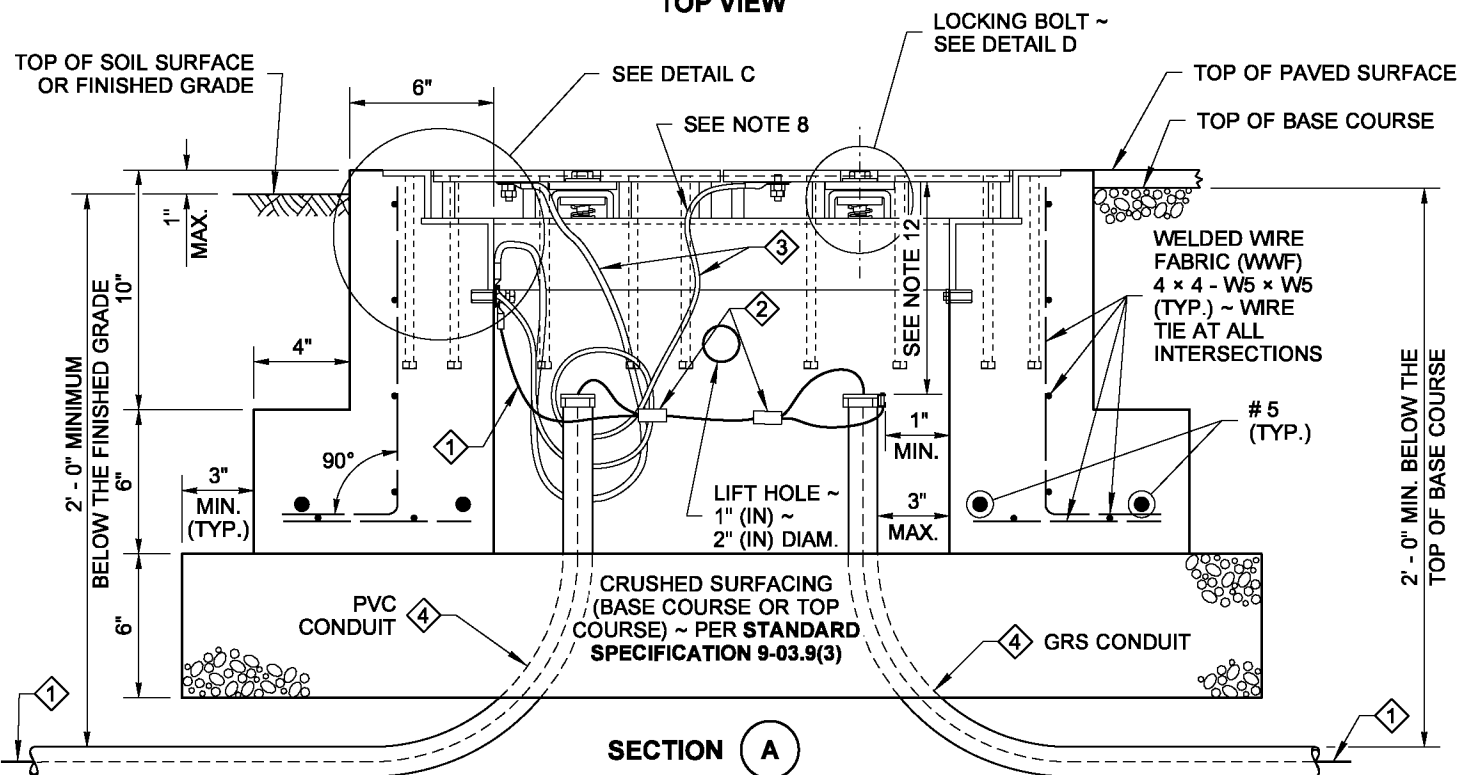

**HEAVY-DUTY JUNCTION BOX TYPES 4, 5, & 6**  
**STANDARD PLAN J-40.20-03**

SHEET 1 OF 2 SHEETS

APPROVED FOR PUBLICATION

STATE DESIGN ENGINEER  
 Washington State Department of Transportation

DRAWN BY: LISA CYFORD

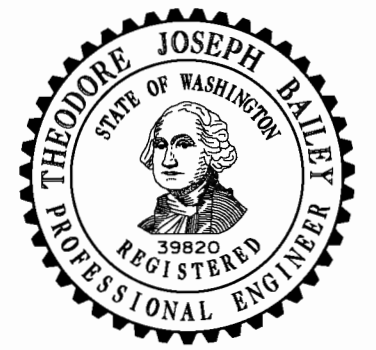
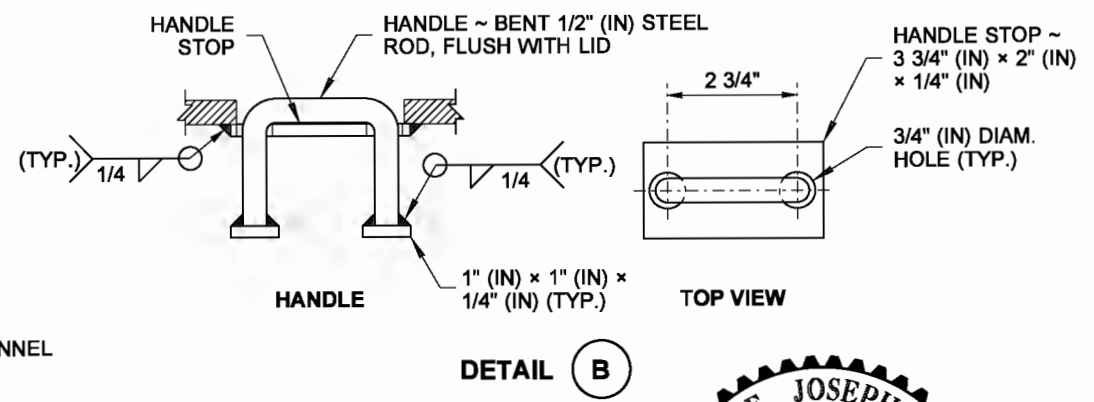
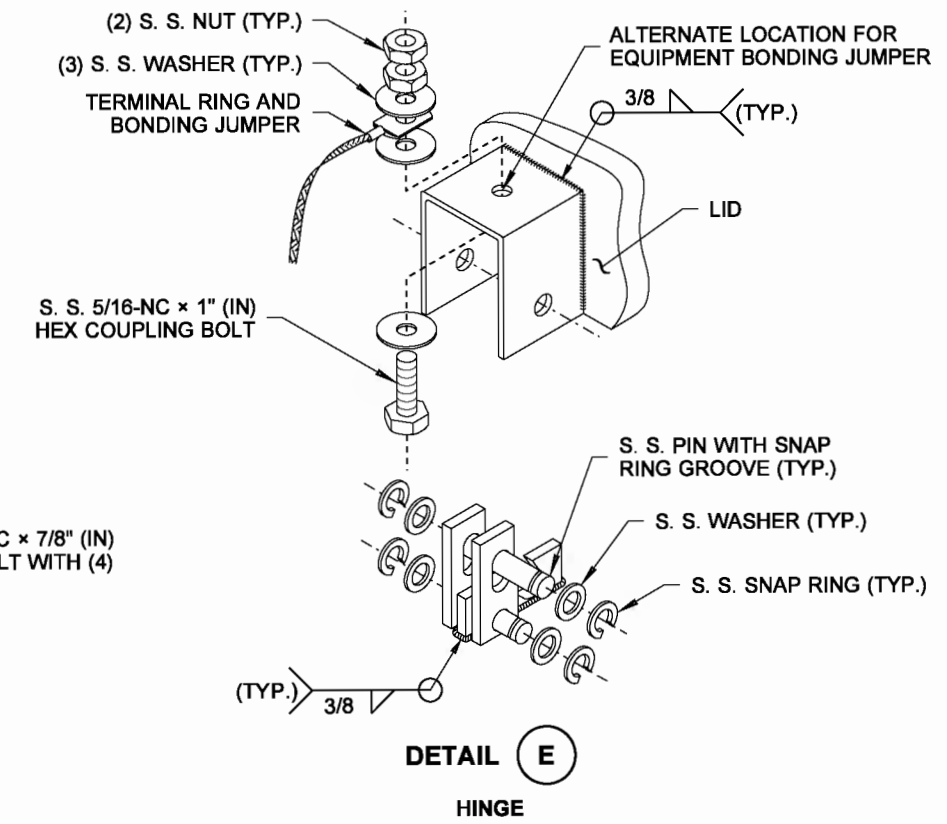
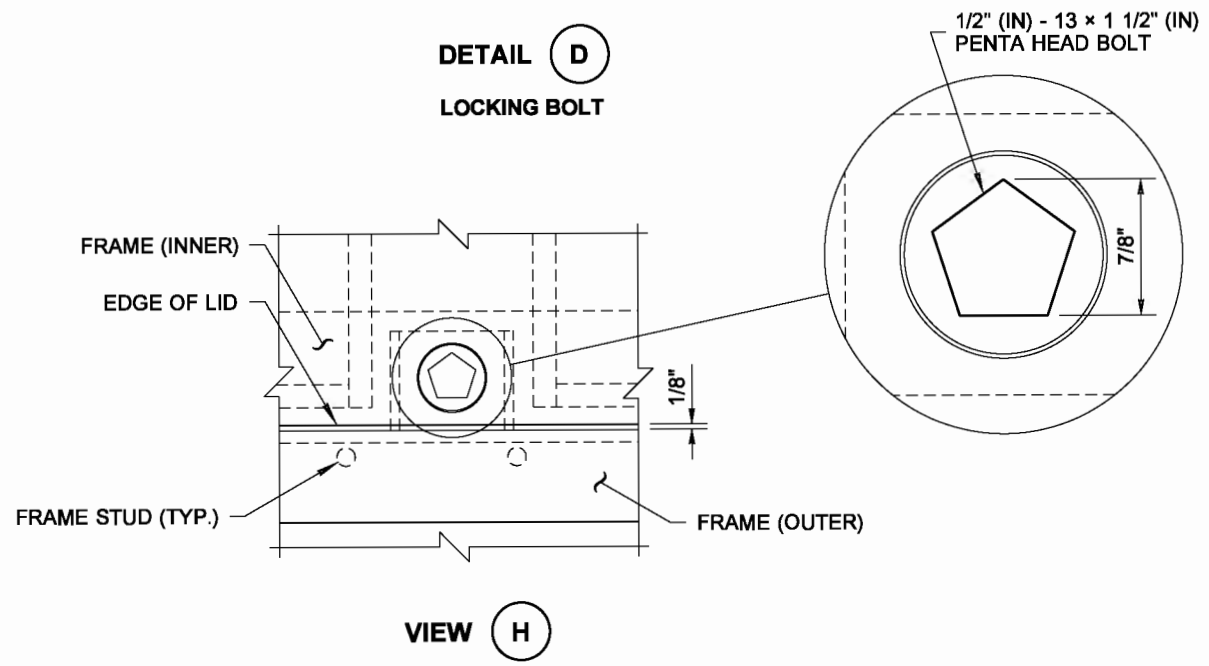
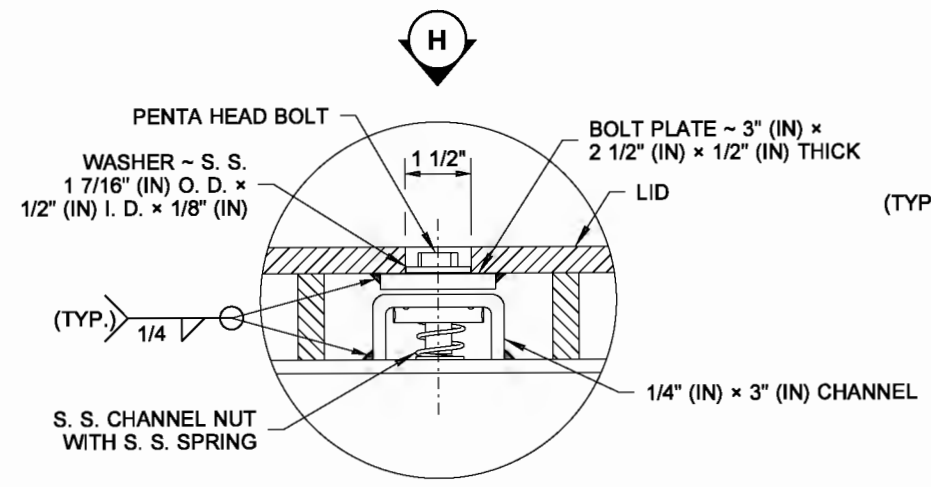
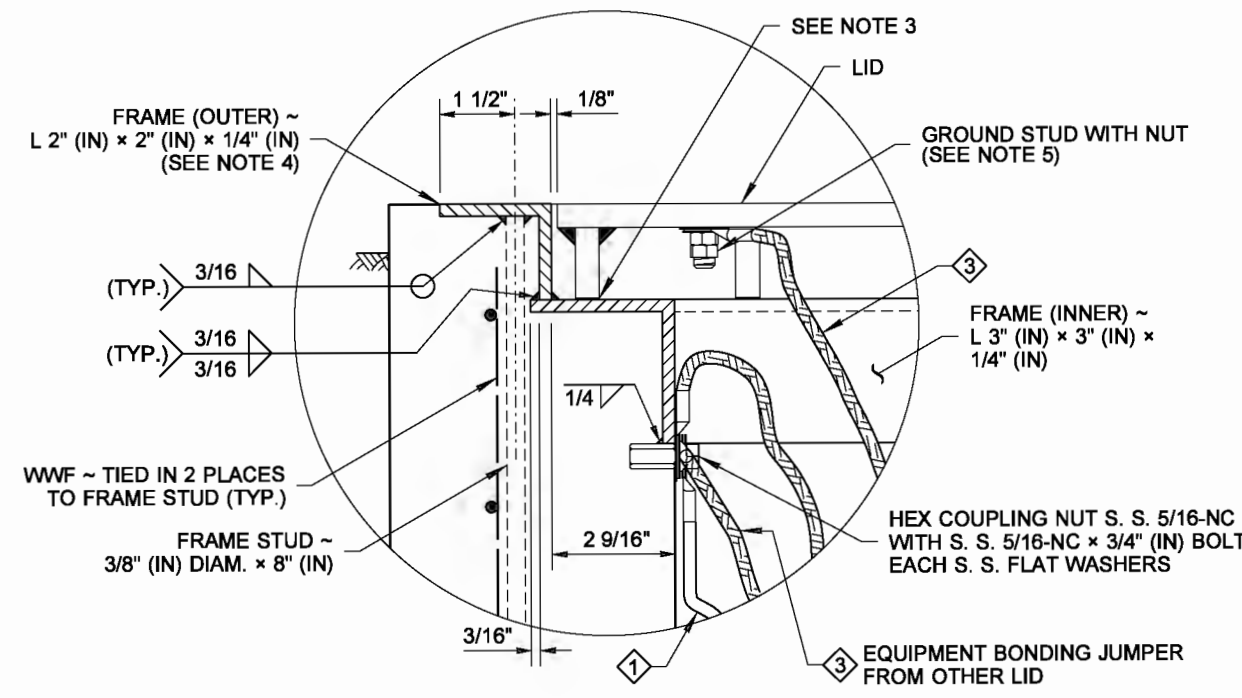
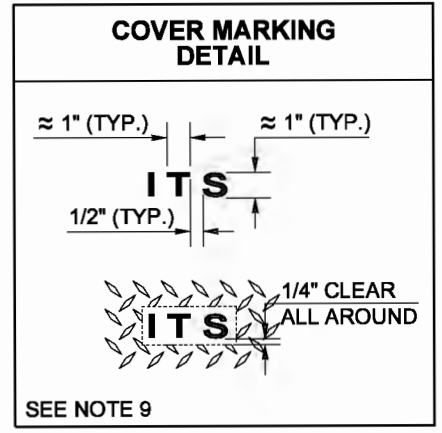
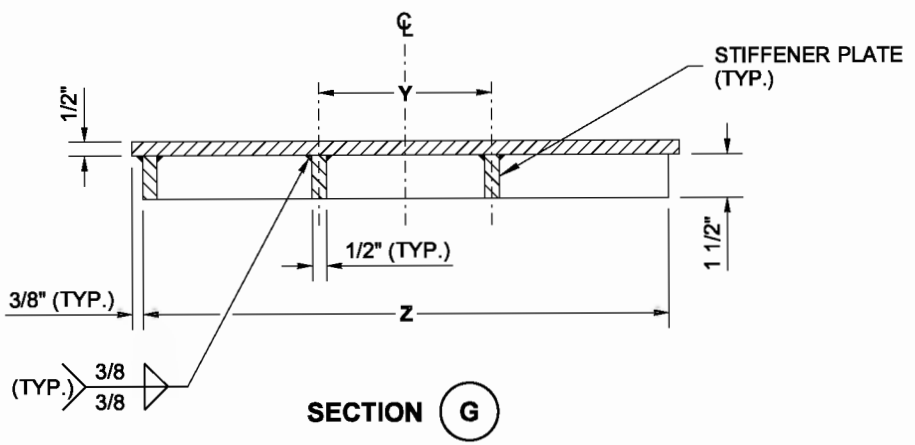
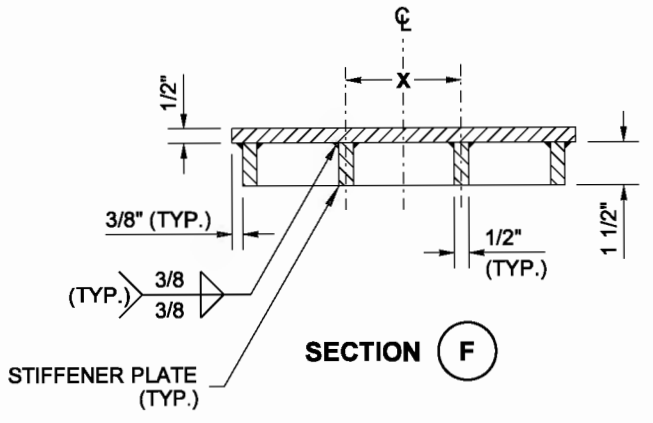
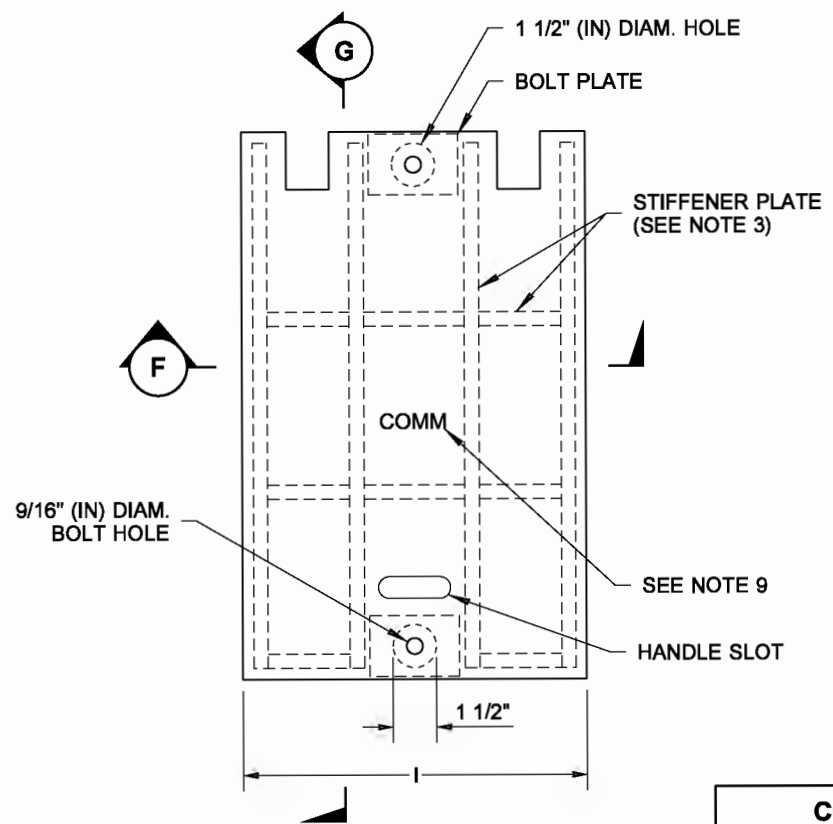

**HEAVY-DUTY JUNCTION BOX TYPES 4, 5, & 6**  
**STANDARD PLAN J-40.20-03**

SHEET 2 OF 2 SHEETS

APPROVED FOR PUBLICATION

STATE DESIGN ENGINEER  
Washington State Department of Transportation